

Dear customer

LAPIS Semiconductor Co., Ltd. ("LAPIS Semiconductor"), on the 1<sup>st</sup> day of October, 2020, implemented the incorporation-type company split (shinsetsu-bunkatsu) in which LAPIS established a new company, LAPIS Technology Co., Ltd. ("LAPIS Technology") and LAPIS Technology succeeded LAPIS Semiconductor's LSI business.

Therefore, all references to "LAPIS Semiconductor Co., Ltd.", "LAPIS Semiconductor" and/or "LAPIS" in this document shall be replaced with "LAPIS Technology Co., Ltd."

Furthermore, there are no changes to the documents relating to our products other than the company name, the company trademark, logo, etc.

Thank you for your understanding.

LAPIS Technology Co., Ltd.  
October 1, 2020



## ML22Q532 / ML22Q533 / ML22Q535

4-Channel Mixing Speech Synthesis LSIs with Built-in Flash Memory for Automotive

### ■ Overview

ML22Q532/ML22Q533/ML22Q535 is a 4-channel mixing speech synthesis LSI with a serial audio interface and a built-in flash-memory for sound data.

It adopts a HQ-ADPCM<sup>\*1</sup>, 16-bit D/A converter, and low-pass filter for high sound quality, and incorporates a 1.0W mono speaker amplifier for driving speakers directly. It is also equipped with a function to detect failure.

The functions necessary for sound output are integrated into a single chip, so that sound functions can be realized simply by adding this LSI.

- Memory capacity and maximum sound production time (HQ-ADPCM<sup>\*1</sup> algorithm, registered phrase 1024)

| Product Name | Flash memory capacity | Maximum sound production time (sec) |                      |                      |
|--------------|-----------------------|-------------------------------------|----------------------|----------------------|
|              |                       | $f_s=8.0\text{kHz}$                 | $f_s=16.0\text{kHz}$ | $f_s=32.0\text{kHz}$ |
| ML22Q532     | 2Mbits                | 80                                  | 40                   | 20                   |
| ML22Q533     | 4Mbits                | 161                                 | 81                   | 40                   |
| ML22Q535     | 16Mbits               | 652                                 | 326                  | 163                  |

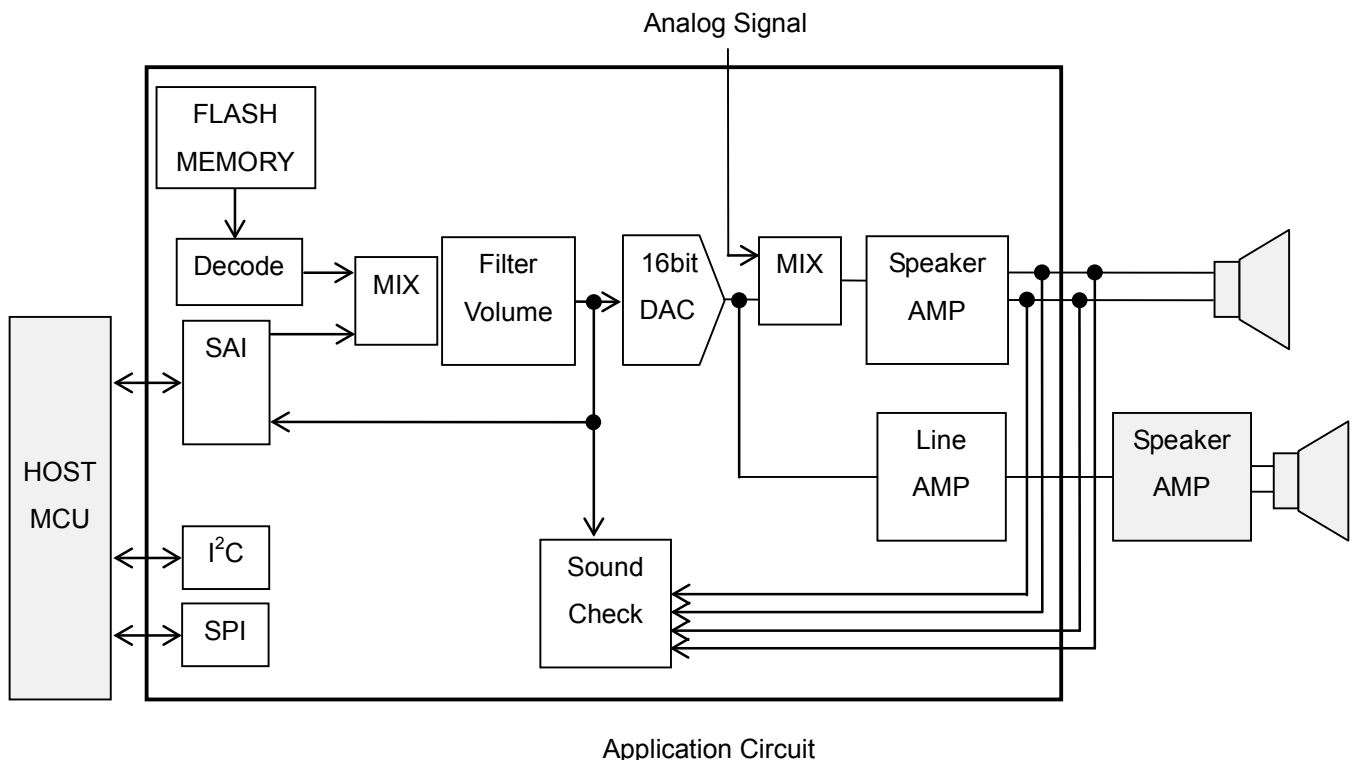

\*1  Ky's Technology

HQ-ADPCM is "Ky's" high-quality audio compression technique. "Ky's" is a registered trademark of Kyushu Institute of Technology, a national university corporation.

## ■ Feature

- Sound data
  - Speech synthesis algorithm: The algorithm can be specified for each phrase.  
HQ-ADPCM/4bit ADPCM/8bit non-linear PCM /  
8bit Straight PCM/16bit Straight PCM
  - Sampling frequency: The sampling frequency can be specified for each phrase.  
10.7/21.3kHz,  
6.4/12.8/25.6kHz,  
8.0/16.0/32.0kHz,  
11.025/22.05/44.1kHz,  
12.0/24.0/48.0kHz
  - Maximum number of phrases: 4096 Phrases
- Edit ROM function
- Playback function
  - Repeat function: LOOP command
  - Mixing-function: Up to 4-channel \*1
  - Volume adjustment function: CVOL command 128 levels (including off-state)  
AVOL command 16 levels (including off-state)
- Serial audio interface (slave)
  - PCM format: 8bit Straight PCM/16bit Straight PCM
  - Sampling frequency: 8.0/16.0/32.0kHz,  
11.025/22.05/44.1kHz,  
12.0/24.0/48.0kHz
  - Data length: 8bit/16bit
  - BCLK frequency: 32fs to 64fs
  - LRCLK transfer mode
  - LRCLK forward/reverse selectable
  - 1-bit delay ON/OFF selectable
  - MSB first/LSB first selectable
- Low-pass filter
- 16-bit D/A converter
- Speaker amplifier: Class AB 1.0W 8Ω (SPV<sub>DD</sub> = 5V, Ta = 25 °C)
- Line amplifier output: 10kΩ driving (Exclusive operation from speaker amplifier output)
- External analog sound input (with analog mixing function)
- MCU command interface: Clock Synchronous Serial Interface/I<sup>2</sup>C Interface (Slave)
- Failure detection function
  - Playback sound error detection
  - Speaker short detection: Speaker pin ground fault detection, speaker pin short detection
  - Speaker disconnection detection
  - Thermal detection
  - Clock error detection
  - Flash memory error detection
- Clock backup function
- Master clock frequency: 4.096MHz, 4.000MHz
- Power-supply voltage: 2.7V to 5.5V\*2  
DV<sub>DD</sub>, SPV<sub>DD</sub>/SPOV<sub>DD</sub> and IOV<sub>DD</sub> can be set independently.  
(SPV<sub>DD</sub> = SPOV<sub>DD</sub> ≥ DV<sub>DD</sub>)
- Operating temperature range: -40 °C to +105 °C\*3
- Package: 48-pin TQFP (7mm x 7mm, 0.5mm pitch)
- Ordered Part Name: ML22Q53X-NNNTB, ML22Q53X-xxxTB (48-pin TQFP)\*4

\*1 Mixing with SAI is limited by the sampling frequency. Refer to the "Function description".

\*2 Handle V<sub>DDR</sub> pin in two different ways depending on the voltage range 2.7-3.6V or 3.3-5.5V.  
Refer to the "Application Circuit".

\*3 The operating time of the speaker amplifier may be limited depending on the average ambient temperature (Ta) used.

\*4 The NNN is blanked. xxx represents ROM code number.

■ Pin Configuration (TOP VIEW)

- ML22Q53X-NNNTB/ML22Q53X-xxxTB

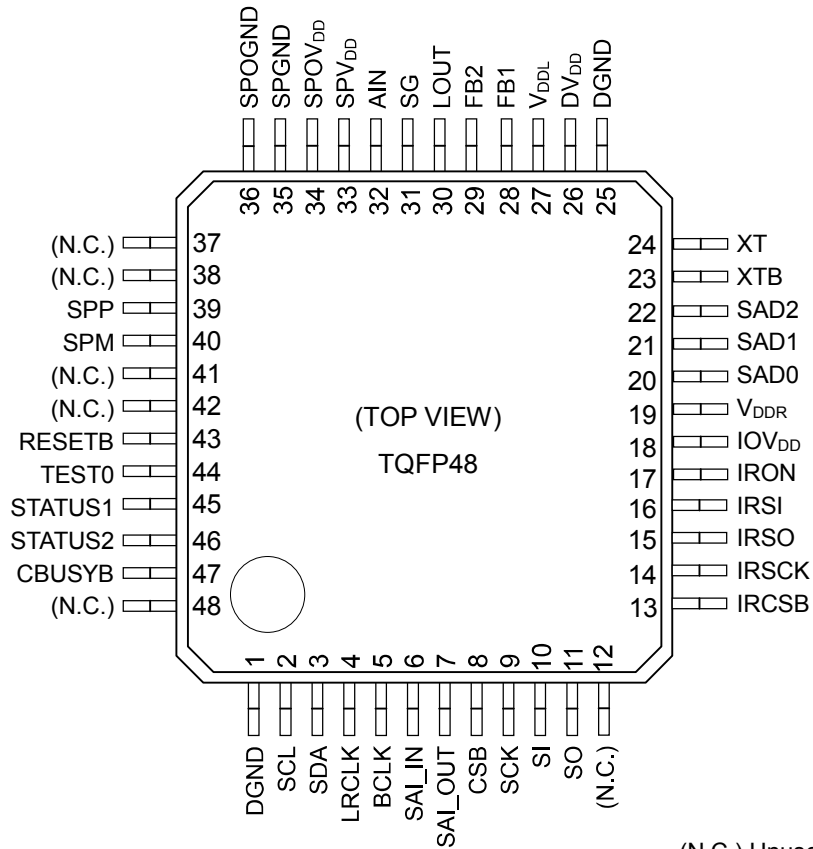

## ■ Pin Description

| Pin  | Symbol  | I/O | Attribute | Description   | Initial value <sup>*1</sup> |
|------|---------|-----|-----------|---|-----------------------------|
| 1,25 | DGND    | G   | -         | Digital ground pin.   | —                           |
| 2    | SCL     | I   | -         | I <sup>2</sup> C slave serial clock pin.<br>When using an I <sup>2</sup> C, be sure to insert a pull-up resistor between DV <sub>DD</sub> pin.<br>Accessing with clock synchronous serial interface at the same time is prohibited.   | H                           |
| 3    | SDA     | IO  | -         | I <sup>2</sup> C slave serial data input/output pin.<br>When using an I <sup>2</sup> C, be sure to insert a pull-up resistor between DV <sub>DD</sub> pin.<br>Output: Nch MOS OPEN DRAIN output<br>Input: High-impedance input<br>Accessing with clock synchronous serial interface at the same time is prohibited.   | H                           |
| 4    | LRCLK   | I   | -         | SAI word clock input pin.   | L                           |
| 5    | BCLK    | I   | -         | SAI bit clock input pin.  | L                           |
| 6    | SAI_IN  | I   | -         | SAI bit data input pin.<br>The data are loaded at the rising edges of BCLK.   | L                           |
| 7    | SAI_OUT | O   | -         | SAI bit data output pin. Output data at the falling edge of BCLK.   | L                           |
| 8    | CSB     | I   | Negative  | Clock synchronous serial interface chip select pin.<br>The SCK and SI inputs are accepted only when this pin is at the "L" level.<br>Accessing with I <sup>2</sup> C slave interface at the same time is prohibited.  | H                           |
| 9    | SCK     | I   | -         | Clock synchronous serial interface clock input pin.<br>Accessing with I <sup>2</sup> C slave interface at the same time is prohibited.  | L                           |
| 10   | SI      | I   | -         | Clock synchronous serial interface data input pin.<br>Data is fetched in synchronization with SCK.<br>Accessing with I <sup>2</sup> C slave interface at the same time is prohibited.   | L                           |
| 11   | SO      | O   | -         | Clock synchronous serial interface data output pin.<br>When the CSB pin is at an "L" level, data is output in synchronization with SCK.<br>When the CSB pin is at an "H" level, this pin enters a high-impedance state.<br>Accessing with I <sup>2</sup> C slave interface at the same time is prohibited.  | Hi-Z                        |
| 13   | IRCSB   | I   | Negative  | Flash memory interface chip select input pin.<br>Input the "H" level during non-access and the "L" level during access.<br>Setting the IRON pin to "H" enables input.   | H                           |
| 14   | IRSCK   | I   | -         | Flash memory interface serial clock input pin.<br>Setting the IRON pin to "H" enables input.  | H                           |
| 15   | IRSO    | O   | -         | Flash memory interface serial data output pin.<br>Setting the IRON pin to "H" enables output.   | Hi-Z <sup>*2</sup>          |
| 16   | IRSI    | I   | -         | Flash memory interface serial data input pin.<br>Setting the IRON pin to "H" enables input.   | L                           |
| 17   | IRON    | I   | Positive  | Pin to enable the flash memory interface.<br>When this bit is set to "L", the flash memory interface pin is disabled. A pull-down resistor is internally connected to the LSI.<br>Set this bit to "L" during playback operation using flash memory.<br>Setting this bit to "H" allows rewriting of the flash memory using the flash memory interface.<br>Set this bit to "H" for onboard rewriting. | L                           |

\*1 Initial value at reset input and power-down. The pin whose IO is "I" indicates a fixed level from outside.

\*2 IRON pin "L" setting status

| Pin | Symbol             | I/O | Attribute | Description   | Initial value <sup>*1</sup> |
|-----|--------------------|-----|-----------|---|-----------------------------|
| 18  | IOV <sub>DD</sub>  | P   | -         | Flash memory interface power supply pin.<br>Connect to DV <sub>DD</sub> pin even when not using flash memory interface.<br>Connect a bypass capacitor between this pin and the DGND pin.  | —                           |
| 19  | V <sub>DDR</sub>   | O   | -         | 3.0V regulator outputs. Used as a power supply for flash memory.<br>Connect a capacitor between this pin and DGND pin as close as possible.<br>Connect this pin to the DV <sub>DD</sub> pin when DV <sub>DD</sub> = 2.7 to 3.6V.  | L                           |
| 20  | SAD0               | I   | -         | I <sup>2</sup> C slave address select pin.  | —                           |
| 21  | SAD1               | I   | -         | I <sup>2</sup> C slave address select pin.  | —                           |
| 22  | SAD2               | I   | -         | I <sup>2</sup> C slave address select pin.  | —                           |
| 23  | XTB                | O   | Negative  | Crystal or ceramic resonator connection pin.<br>When an external clock is used, leave it open and capacitor is not required when a crystal or ceramic resonator is connected.<br>When using a resonator, connect it as close as possible.<br>Leave it open when not in use.   | H                           |
| 24  | XT                 | I   | Positive  | Crystal or ceramic resonator connection pin.<br>A feedback resistor of about 1MΩ is built in between the XT pin and the XTB pin.<br>To use an external clock, input from this pin. Delete the capacitor when a crystal or ceramic resonator is connected.<br>When using a resonator, connect it as close as possible.<br>Leave it open when not in use. | L                           |
| 26  | DV <sub>DD</sub>   | P   | -         | Digital power supply pin.<br>Connect a bypass capacitor between this pin and the DGND pin.  | —                           |
| 27  | V <sub>DDL</sub>   | O   | -         | 2.5V regulator output pin.<br>Used as internal power supply.<br>Connect a capacitor between this pin and DGND pin as close as possible.   | L                           |
| 28  | FB1                | I   | -         | Analog input pin 1 for playback sound error detection.  | L                           |
| 29  | FB2                | I   | -         | Analog input pin 2 for playback sound error detection.  | L                           |
| 30  | LOUT               | O   | -         | This pin is used exclusively for line amplifier output.   | L                           |
| 31  | SG                 | O   | -         | Reference voltage output pin for the built-in speaker amplifier.<br>Connect a capacitor between this pin and SPGND pin.   | L                           |
| 32  | AIN                | I   | -         | Speaker amplifier analog signal input pin.<br>Initially, input is disabled.   | L                           |
| 33  | SPV <sub>DD</sub>  | P   | -         | Power supply pin for speaker amplifier.<br>Connect a bypass capacitor between this pin and the SPGND pin.   | —                           |
| 34  | SPOV <sub>DD</sub> | P   | -         | Power supply pin for the speaker amplifier output circuit.<br>Set it at the same potential as the SPV <sub>DD</sub> pin.  | —                           |
| 35  | SPGND              | G   | -         | Speaker amplifier ground pin.   | —                           |
| 36  | SPOGND             | G   | -         | Ground pin for the speaker amplifier output circuit.<br>Set it at the same potential as the SPGND pin.  | —                           |
| 39  | SPP                | O   | -         | Positive output pin of the speaker amplifier.<br>Line amplifier outputs are also available with AMODE command.  | L                           |
| 40  | SPM                | O   | -         | Negative output pin of the speaker amplifier.   | Hi-Z                        |

\*1 Initial value at reset input and power-down. The pin whose IO is "I" indicates a fixed level from outside.

| Pin                       | Symbol  | I/O | Attribute | Description   | Initial value <sup>*1</sup> |
|---------------------------|---------|-----|-----------|---|-----------------------------|
| 43                        | RESETB  | I   | Negative  | Reset input pin.<br>The LSI is initialized by the "L" level input. After a reset is input, all the circuits stop operating and enter the power-down state.<br>At power-on, input an "L" level to this pin. After the power supply voltage stabilizes, set this pin to an "H" level.<br>A pull-up resistor is internally connected to the LSI. | ( <sup>2</sup> )            |
| 44                        | TEST0   | I   | Positive  | Input pin for testing.<br>A pull-down resistor is internally connected to the LSI.<br>Fix to the DGND.  | L                           |
| 45                        | STATUS1 | O   | -         | Status/error output pin 1.<br>Execute OUTSTAT command to select BUSYB <sup>*3</sup> and NCR <sup>*3</sup> in each channel, or errors.<br>The initial value is BUSYB <sup>*3</sup> of channel 0, and output data is "H" level.   | H                           |
| 46                        | STATUS2 | O   | -         | Status/error output pin 2.<br>Execute OUTSTAT command to select BUSYB <sup>*3</sup> and NCR <sup>*3</sup> in each channel, or errors.<br>The initial value is BUSYB <sup>*3</sup> of channel 0, and output data is "H" level.   | H                           |
| 47                        | CBUSYB  | O   | Negative  | Command processing status signal output pin.<br>An "L" level is output during command processing.<br>Be sure to input a command with this pin at an "H" level.  | ( <sup>2</sup> )            |
| 12,37,<br>38,41,<br>42,48 | N.C.    | -   | -         | Unused pin.<br>Leave open.  | Hi-Z                        |

\*1 Initial value at reset input and power-down. The pin whose IO is "I" indicates a fixed level from outside.

\*2 "L" at reset, "H" at power-down

\*3 For NCR, BUSYB, refer to the description of "RDSTAT command".

## ■ Termination of Unused Pins

This section explains how to terminate unused pins.

| Symbol  | Recommended pin termination       |
|---------|-----------------------------------|
| SCL     | Connect to the DV <sub>DD</sub> . |
| SDA     |                                   |
| SAD0    |                                   |
| SAD1    | Connect to the DGND.              |
| SAD2    |                                   |
| LRCLK   |                                   |
| BCLK    | Connect to the DGND.              |
| SAI_IN  |                                   |
| CSB     | Connect to the DV <sub>DD</sub> . |
| SCK     |                                   |
| SI      | Connect to the DGND.              |
| IRON    |                                   |
| XT      | Leave open.                       |
| XTB     |                                   |
| FB1     | Connect to the SPGND.             |
| FB2     |                                   |
| AIN     | Connect to the SPGND.             |
| TEST0   |                                   |
| N.C.    | Leave open.                       |
| SAI_OUT |                                   |
| SO      |                                   |
| LOUT    |                                   |
| SPP     |                                   |
| SPM     |                                   |
| STATUS1 |                                   |
| STATUS2 |                                   |

■ I/O Equivalent Circuit

| Classification | Circuit | Overview   |
|----------------|---------|--|
| A              |         | <p>Attribute: Input<br/>                     Power: <math>DV_{DD}</math><br/>                     Function: CMOS inputs with pull-down<br/>                     Applicable pin: TEST0</p>                                |
| B              |         | <p>Attribute: Input<br/>                     Power: <math>IOV_{DD}</math><br/>                     Function: CMOS inputs with pull-down<br/>                     Applicable pin: IRON</p>                                |
| C              |         | <p>Attribute: Input<br/>                     Power: <math>DV_{DD}</math><br/>                     Function: CMOS inputs with pull-up<br/>                     Applicable pin: RESETB</p>                                 |
| D              |         | <p>Attribute: Input<br/>                     Power: <math>DV_{DD}</math><br/>                     Function: CMOS inputs<br/>                     Applicable pins: SI SCK, CSB, SAD0, SAD1, SAD2, LRCLK, BCLK, SAI_IN</p> |
| E              |         | <p>Attribute: Input<br/>                     Power: <math>IOV_{DD}</math><br/>                     Function: CMOS inputs<br/>                     Applicable pins: IRCSB, IRSCK</p>                                      |

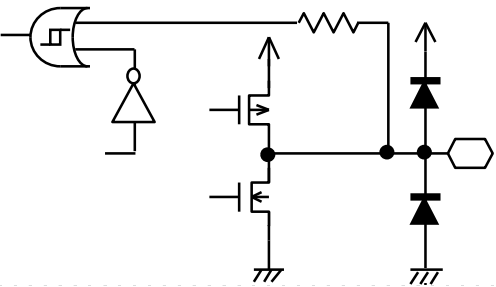
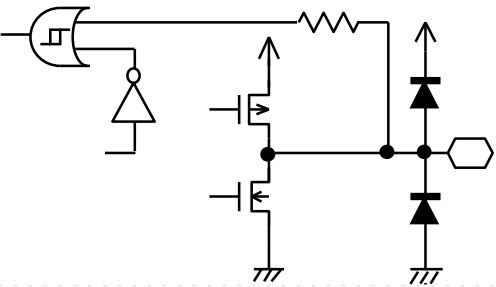
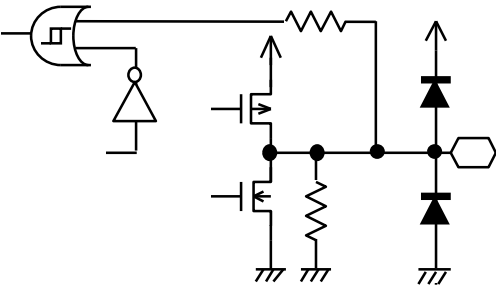
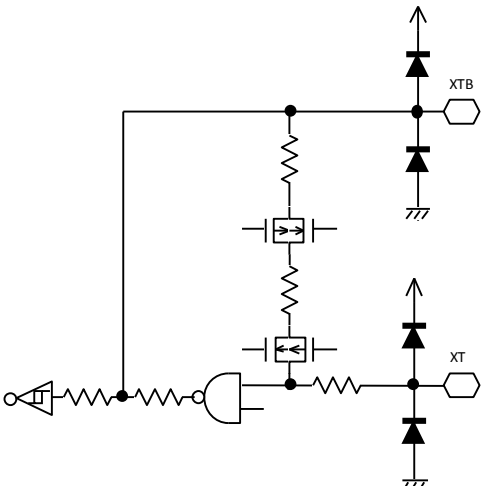

| Classification | Circuit   | Overview   |
|----------------|---|--|
| F              |    | <p>Attribute: Input/output<br/>                     Power: <math>DV_{DD}</math><br/>                     Function: CMOS inputs<br/>                     Function: CMOS outputs<br/>                     Applicable pins: STATUS1, STATUS2, CBUSYB, SO, SAI_OUT</p> |
| G              |   | <p>Attribute: Input/output<br/>                     Power: <math>IOV_{DD}</math><br/>                     Function: CMOS inputs<br/>                     Function: CMOS outputs<br/>                     Applicable pin: IRSI</p>                                  |
| H              |  | <p>Attribute: Input/output<br/>                     Power: <math>IOV_{DD}</math><br/>                     Function: CMOS inputs with pull-down<br/>                     Function: CMOS outputs<br/>                     Applicable pin: IRSO</p>                   |
| I              |  | <p>Attribute: Oscillator circuit<br/>                     Power: <math>DV_{DD}</math><br/>                     Function: 4.096M, 4.000MHz oscillation<br/>                     Applicable pins: XT, XTB</p>  |

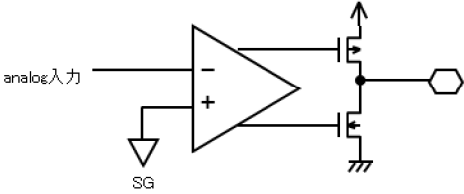
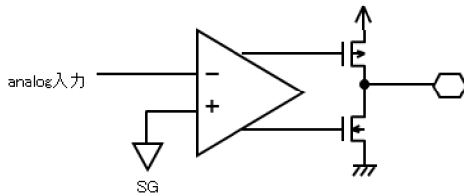
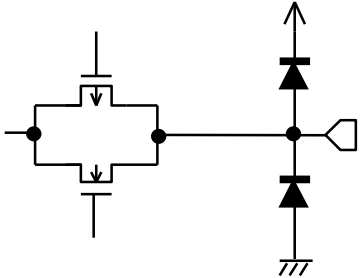
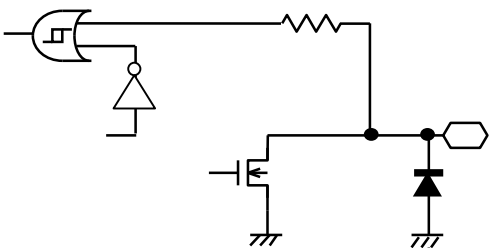
| Classification | Circuit   | Overview  |
|----------------|---|---|
| J              |    | <p>Attribute: Analog<br/>                     Power: <math>SPOV_{DD}</math><br/>                     Function: Sound output<br/>                     Applicable pins: SPP, SPM</p>    |
| K              |   | <p>Attribute: Analog<br/>                     Power: <math>SPOV_{DD}</math><br/>                     Function: Sound output<br/>                     Applicable pin: LOUT</p>         |
| L              |  | <p>Attribute: Analog<br/>                     Power: <math>SPV_{DD}</math><br/>                     Function: Sound input<br/>                     Applicable pins: AIN, FB1, FB2</p> |
| M              |  | <p>Attribute: Input<br/>                     Power: <math>DV_{DD}</math><br/>                     Function: Nch Open Drain<br/>                     Applicable pins: SCL, SDA</p>     |

## ■ Electrical characteristics

### ● Absolute maximum rating

DGND=SPGND=SPOGND=0V, Ta=25°C

| Parameter                    | Symbol   | Condition  | Rating                         | Unit |
|------------------------------|--|--|--------------------------------|------|
| Power supply voltage 1       | DV <sub>DD</sub><br>IOV <sub>DD</sub><br>SPV <sub>DD</sub><br>SPOV <sub>DD</sub> | —  | -0.3 to +6.0                   | V    |
| Power supply voltage 2       | V <sub>DDR</sub>   | —  | -0.3 to +4.6                   | V    |
| Input voltage 1              | V <sub>IN1</sub>   | —  | -0.3 to DV <sub>DD</sub> +0.3  | V    |
| Input voltage 2              | V <sub>IN2</sub>   | —  | -0.3 to IOV <sub>DD</sub> +0.3 | V    |
| Input voltage 3              | V <sub>IN3</sub>   | Applies to the FB1 and FB2 pins.   | -0.3 to SPV <sub>DD</sub> +0.3 | V    |
| Allowable loss               | P <sub>D</sub>   | When the LSI is mounted on JEDEC 4-layer board.<br>SPV <sub>DD</sub> = SPOV <sub>DD</sub> = 5V | 1000                           | mW   |
| Output short-circuit current | I <sub>OS</sub>  | Applies to pins other than SPM, SPP, V <sub>DDL</sub> and V <sub>DDR</sub> pins.               | 10                             | mA   |
|                              |  | Applies to SPM and SPP pins.   | 500                            | mA   |
|                              |  | Applies to the V <sub>DDL</sub> /V <sub>DDR</sub> pin.   | 50                             | mA   |
| Storage temperature          | T <sub>STG</sub>   | —  | -55 to +150                    | °C   |

### ● Recommended operating conditions

DGND=SPGND=SPOGND=0V

| Parameter   | Symbol   | Condition | Range                   | Unit  |      |     |
|---|--|-----------|-------------------------|-------|------|-----|
| DV <sub>DD</sub> ,<br>IOV <sub>DD</sub> ,<br>SPV <sub>DD</sub> <sup>*1</sup> , SPOV <sub>DD</sub> <sup>*1</sup><br>Power-supply voltage | DV <sub>DD</sub><br>IOV <sub>DD</sub><br>SPV <sub>DD</sub><br>SPOV <sub>DD</sub> | —         | 2.7 to 3.6 / 3.3 to 5.5 | V     |      |     |
| Operating temperature   | T <sub>OP</sub>  | —         | -40 to +105             | °C    |      |     |
| Master clock frequency  | f <sub>OSC</sub>   | —         | Min.                    | Typ.  | Max. | MHz |
|   |  |           | Typ                     |       |      |     |
|   |  |           | -5%                     | 4.000 | +5%  |     |

\*1 SPV<sub>DD</sub>=SPOV<sub>DD</sub>≥DV<sub>DD</sub>

### ● Flash memory condition

| Parameter             | Symbol          | Condition      | Range       | Unit |
|-----------------------|-----------------|----------------|-------------|------|
| Operating temperature | T <sub>OP</sub> | At write/erase | 0 to +70    | °C   |
|                       |                 | At read        | -40 to +105 | °C   |
| Number of rewrites    | C <sub>EP</sub> | —              | 100         | Time |
| Data retention period | Y <sub>DR</sub> | —              | 10          | Year |

## ● DC characteristics

SPV<sub>DD</sub>=SPOV<sub>DD</sub>≥DV<sub>DD</sub>=IOV<sub>DD</sub>=2.7 to 5.5V, DGND=SPGND=SPOGND=0V, Ta=-40 to +105°C, Load capacitance of output pin =15pF(Max.)

| Parameter                | Symbol            | Condition  | Applicable pin   | Min.                   | Typ. <sup>**1</sup> | Max.                  | Unit |
|--------------------------|-------------------|--|--|------------------------|---------------------|-----------------------|------|
| "H" input voltage 1      | V <sub>IH1</sub>  | —  | LRCLK/BCLK/SAI_IN/<br>CSB/SCK/SI/<br>SAD0/SAD1/SAD2/<br>SDA/SCL/<br>XT/RESETB/TEST0  | 0.8×DV <sub>DD</sub>   | —                   | DV <sub>DD</sub>      | V    |
| "H" input voltage 2      | V <sub>IH2</sub>  | —  | IRCSB/IRSCK/<br>IRSI/IRON  | 0.8×IOV <sub>DD</sub>  | —                   | IOV <sub>DD</sub>     | V    |
| "L" input voltage 1      | V <sub>IL1</sub>  | —  | LRCLK/BCLK/SAI_IN/<br>CSB/SCK/SI/<br>SAD0/SAD1/SAD2/<br>SDA/SCL/<br>XT/RESETB/TEST0  | 0                      | —                   | 0.2×DV <sub>DD</sub>  | V    |
| "L" input voltage 2      | V <sub>IL2</sub>  | —  | IRCSB/IRSCK/IRSI/<br>IRON  | 0                      | —                   | 0.2×IOV <sub>DD</sub> | V    |
| "H" output voltage 1     | V <sub>OH1</sub>  | I <sub>OH</sub> = -50μA                            | XTB  | DV <sub>DD</sub> -0.4  | —                   | —                     | V    |
| "H" output voltage 2     | V <sub>OH2</sub>  | I <sub>OH</sub> = -1mA                             | SAI_OUT/<br>SO/<br>CBUSYB/STATUS1/<br>STATUS2  | DV <sub>DD</sub> -0.4  | —                   | —                     | V    |
| "H" output voltage 3     | V <sub>OH3</sub>  | I <sub>OH</sub> = -1mA                             | IRSO   | IOV <sub>DD</sub> -0.4 | —                   | —                     | V    |
| "L" output voltage 1     | V <sub>OL1</sub>  | I <sub>OL</sub> = 50μA                             | XTB  | —                      | —                   | 0.4                   | V    |
| "L" output voltage 2     | V <sub>OL2</sub>  | I <sub>OL</sub> = 2mA                              | SAI_OUT/<br>SO/<br>CBUSYB/STATUS1/<br>STATUS2  | —                      | —                   | 0.4                   | V    |
| "L" output voltage 3     | V <sub>OL3</sub>  | I <sub>OL</sub> = 2mA                              | IRSO   | —                      | —                   | 0.4                   | V    |
| "L" output voltage 4     | V <sub>OL4</sub>  | I <sub>OL</sub> = 3mA                              | SDA/SCL  | —                      | —                   | 0.4                   | V    |
| Output leakage current 1 | I <sub>OOH1</sub> | VOH=DV <sub>DD</sub><br>(in high-impedance state)  | SDA/SCL/<br>SO   | —                      | —                   | 10                    | μA   |
|                          | I <sub>OOL1</sub> | VOL=DGND<br>(in high-impedance state)              |  | -10                    | —                   | —                     | μA   |
| Output leakage current 2 | I <sub>OOH2</sub> | VOH=IOV <sub>DD</sub><br>(in high-impedance state) | IRSO   | —                      | —                   | 10                    | μA   |
|                          | I <sub>OOL2</sub> | VOL=DGND<br>(in high-impedance state)              |  | -10                    | —                   | —                     | μA   |
| "H" input current 1      | I <sub>IH1</sub>  | V <sub>IH</sub> = DV <sub>DD</sub>                 | XT   | 0.8                    | 5.0                 | 20                    | μA   |
| "H" input current 2      | I <sub>IH2</sub>  | V <sub>IH</sub> = DV <sub>DD</sub>                 | RESETB/<br>LRCLK/BCLK/SAI_IN/<br>CSB/SCK/SI/<br>SDA/SCL                              | —                      | —                   | 10                    | μA   |
| "H" input current 3      | I <sub>IH3</sub>  | V <sub>IH</sub> = DV <sub>DD</sub>                 | TEST0  | 20                     | 500                 | 1000                  | μA   |
| "H" input current 4      | I <sub>IH4</sub>  | V <sub>IH</sub> = IOV <sub>DD</sub>                | IRCSB/IRSCK/IRSI   | —                      | —                   | 10                    | μA   |
| "H" input current 5      | I <sub>IH5</sub>  | V <sub>IH</sub> = IOV <sub>DD</sub>                | IRON   | 20                     | 500                 | 1000                  | μA   |
| "L" input current 1      | I <sub>IL1</sub>  | V <sub>IL</sub> = DGND                             | XT   | -20                    | -5.0                | -0.8                  | μA   |
| "L" input current 2      | I <sub>IL2</sub>  | V <sub>IL</sub> = DGND                             | LRCLK/BCLK/SAI_IN/<br>CSB/SCK/SI/<br>SDA/SCL/<br>IRCSB/IRSCK/IRSI/<br>IRON/<br>TEST0 | -10                    | —                   | —                     | μA   |
| "L" input current 3      | I <sub>IL3</sub>  | V <sub>IL</sub> = DGND                             | RESETB   | -400                   | -100                | -2                    | μA   |

| Parameter                           | Symbol           | Condition   | Applicable pin   | Min. | Typ. <sup>*1</sup> | Max.              | Unit               |    |
|-------------------------------------|------------------|---|------------------|------|--------------------|-------------------|--------------------|----|
| During playback Current consumption | I <sub>DDO</sub> | f <sub>OSC</sub> =4.096MHz<br>Fs=48kHz, f=1kHz,<br>During HQADPCM playback<br>SPP/SPM No output load                        | —                | —    | —                  | 55 <sup>*3</sup>  | mA                 |    |
| Power-down Current consumption      | I <sub>DDS</sub> | DV <sub>DD</sub> =<br>IOV <sub>DD</sub> =<br>SPV <sub>DD</sub> =<br>SPOV <sub>DD</sub> =<br>3.3V~5.5V                       | Ta=-40 to +55°C  | —    | —                  | 1 <sup>*3</sup>   | 10.0 <sup>*3</sup> | μA |
|                                     |                  |   | Ta=-40 to +105°C | —    | —                  | 1 <sup>*3</sup>   | 30.0 <sup>*3</sup> | μA |
|                                     |                  | DV <sub>DD</sub> =<br>IOV <sub>DD</sub> =<br>SPV <sub>DD</sub> =<br>SPOV <sub>DD</sub> =<br>V <sub>DDR</sub> =<br>2.7V~3.6V | Ta=-40 to +55°C  | —    | —                  | 6 <sup>*2*3</sup> | 20.0 <sup>*3</sup> | μA |
|                                     |                  |   | Ta=-40 to +105°C | —    | —                  | 6 <sup>*2*3</sup> | 80.0 <sup>*3</sup> | μA |

\*1 Typ. : DV<sub>DD</sub>=SPV<sub>DD</sub>=SPOV<sub>DD</sub>=IOV<sub>DD</sub>=5.0V, DGND=SPGND=0V, Ta=25°C

\*2 Typ. : DV<sub>DD</sub>=SPV<sub>DD</sub>=SPOV<sub>DD</sub>=IOV<sub>DD</sub>=3.0V, DGND=SPGND=0V, Ta=25°C

\*3 Total values of the DV<sub>DD</sub> pin, SPV<sub>DD</sub> pin, SPOV<sub>DD</sub> pin, and IOV<sub>DD</sub> pin

● Analog Part Characteristics

SPV<sub>DD</sub>=SPOV<sub>DD</sub>≥DV<sub>DD</sub>=IOV<sub>DD</sub>=2.7 to 5.5V, DGND=SPGND=SPOGND=0V, Ta=-40 to +105°C, Load capacitance of output pin =15pF(Max.)

| Parameter   | Symbol             | Condition  | Min.                          | Typ.                 | Max.                          | Unit |
|---|--------------------|--|-------------------------------|----------------------|-------------------------------|------|
| RC4MHz  | Frc                | Ta=-40 to +70°C  | 3.89                          | 4.096                | 4.31                          | MHz  |
|   |                    | Ta=-40 to +105°C   | 3.68                          | 4.096                | 4.51                          | MHz  |
| AIN pin input resistance                            | R <sub>AIN</sub>   | Input gain 0dB   | 10                            | 20                   | 30                            | kΩ   |
| AIN pin input voltage range                         | V <sub>AIN</sub>   | —  | —                             | —                    | SPV <sub>DD</sub> ×2/3        | Vp-p |
| Line amplifier output resistance <sup>*1</sup>      | R <sub>LA1</sub>   | SPV <sub>DD</sub> = 3.3 to 5.5V<br>When 1/2SPV <sub>DD</sub> ± 1 mA is applied           | —                             | —                    | 100                           | Ω    |
| Line amplifier output resistance <sup>*1</sup>      | R <sub>LA2</sub>   | SPV <sub>DD</sub> = 2.7 to 3.6V<br>When 1/2SPV <sub>DD</sub> ± 1 mA is applied           | —                             | —                    | 300                           | Ω    |
| Line amplifier output-load-resistance <sup>*1</sup> | R <sub>LA</sub>    | For SPGND  | 10                            | —                    | —                             | kΩ   |
| Line amplifier Output Voltage Range <sup>*1</sup>   | V <sub>AO</sub>    | No output load   | SPV <sub>DD</sub> /6          | —                    | SPV <sub>DD</sub> ×5/6        | V    |
| SG pin output voltage                               | V <sub>SG</sub>    | —  | 0.95x<br>SPV <sub>DD</sub> /2 | SPV <sub>DD</sub> /2 | 1.05x<br>SPV <sub>DD</sub> /2 | V    |
| SG pin output resistance                            | R <sub>SG</sub>    | —  | 57                            | 96                   | 135                           | kΩ   |
| SPP/SPM pins Output-Load Resistance                 | R <sub>LSP1</sub>  | —  | 6                             | 8                    | —                             | Ω    |
| To the SPP and SPM pins Short circuit detection     | R <sub>OCDAB</sub> | Class AB speaker amplifier<br>4.5V≤SPV <sub>DD</sub> ≤5.5V                               | 0.1                           | —                    | 6                             | Ω    |
| Speaker amplifier output power <sup>1</sup>         | P <sub>SPO1</sub>  | SPV <sub>DD</sub> = SPOV <sub>DD</sub> =5.0V,<br>f=1kHz R <sub>SPO</sub> =8Ω,<br>THD=10% | 0.8                           | 1                    | —                             | W    |
| Speaker amplifier output power <sup>2</sup>         | P <sub>SPO2</sub>  | SPV <sub>DD</sub> = SPOV <sub>DD</sub> =3.0V,<br>f=1kHz R <sub>SPO</sub> =8Ω,<br>THD=10% | 0.1                           | 0.3                  | —                             | W    |
| During no-signal SPM-SPP Output offset voltage      | V <sub>OF</sub>    | AVOL=0dB<br>8 Ω load   | -50                           | —                    | 50                            | mV   |

\*1 Applies to the SPP and LOUT pins when outputting LINE.

## ● AC characteristic

SPV<sub>DD</sub>=SPOV<sub>DD</sub>≥DV<sub>DD</sub>=IOV<sub>DD</sub>=2.7 to 5.5V, DGND=SPGND=SPOGND=0V, Ta=-40 to +105°C, Load capacitance of output pin =15pF(Max.)

| Parameter  | Symbol             | Condition  | Min. | Typ. | Max. | Unit |
|--|--------------------|--|------|------|------|------|
| Master clock duty cycle                                | f <sub>duty</sub>  | —  | 40   | 50   | 60   | %    |
| RESETB input pulse width                               | t <sub>RST</sub>   | —  | 10   | —    | —    | μs   |
| Reset noise rejection pulse width                      | t <sub>NRST</sub>  | RESETB pin   | —    | —    | 0.1  | μs   |
| Command input interval time                            | t <sub>INTC</sub>  | f <sub>OSC</sub> = 4.096MHz<br>After input the first command at two-times command input mode   | 0    | —    | —    | μs   |
| Command input enable time                              | t <sub>cm</sub>    | f <sub>OSC</sub> = 4.096MHz<br>During continuous playback at SLOOP input   | —    | —    | 10   | ms   |
| At PUP command input<br>CBUSYB "L" level output time   | t <sub>PUP</sub>   | 4.096MHz external clock input  | —    | —    | 8    | ms   |
| At AMODE command input<br>CBUSYB "L" level output time | t <sub>PUPA1</sub> | 4.096MHz external clock input<br>POP="L"<br>AEN0="L"→"H"<br>AEN1 = "L"<br>AVOL = -4dB is selected  | 35   | 37   | 39   | ms   |
| At AMODE command input<br>CBUSYB "L" level output time | t <sub>PUPA2</sub> | 4.096MHz external clock input<br>DAMP="L",POP="H"<br>AEN1="L"→"H"<br>(AEN0= "L": SPP-pin line amplifier output)<br>(AEN0= "H": LOUT pin line amplifier output) | 72   | 74   | 76   | ms   |
| At AMODE command input<br>CBUSYB "L" level output time | t <sub>PUPA3</sub> | 4.096MHz external clock input<br>DAMP="L",POP="L"<br>AEN1="L"→"H"<br>(AEN0= "L": SPP-pin line amplifier output)<br>(AEN0= "H": LOUT pin line amplifier output) | 32   | 34   | 36   | ms   |
| At PDWN command input<br>CBUSYB "L" level output time  | t <sub>PD</sub>    | f <sub>OSC</sub> = 4.096MHz  | —    | —    | 10   | μs   |
| At AMODE command input<br>CBUSYB "L" level output time | t <sub>PDA1</sub>  | 4.096MHz external clock input<br>POP="L"<br>AEN1="L",AEN0="H"→"L"  | 106  | 108  | 110  | ms   |
| At AMODE command input<br>CBUSYB "L" level output time | t <sub>PDA2</sub>  | 4.096MHz external clock input<br>DAMP="L",POP="H"<br>AEN1="H"→"L"<br>(AEN0= "L": SPP-pin line amplifier output)<br>(AEN0= "H": LOUT pin line amplifier output) | 143  | 145  | 147  | ms   |
| At AMODE command input<br>CBUSYB "L" level output time | t <sub>PDA3</sub>  | 4.096MHz external clock input<br>DAMP="L",POP="L"<br>AEN1="H"→"L"<br>(AEN0= "L": SPP-pin line amplifier output)<br>(AEN0= "H": LOUT pin line amplifier output) | 103  | 105  | 107  | ms   |
| CBUSYB "L" level output time 1 <sup>*1</sup>           | t <sub>CB1</sub>   | f <sub>OSC</sub> = 4.096MHz  | —    | —    | 10   | μs   |
| CBUSYB "L" level output time 2 <sup>*2</sup>           | t <sub>CB2</sub>   | f <sub>OSC</sub> = 4.096MHz  | —    | —    | 3    | ms   |
| CBUSYB "L" level output time 3 <sup>*3</sup>           | t <sub>CB3</sub>   | FAD="L" at f <sub>OSC</sub> = 4.096MHz   | —    | —    | 200  | μs   |
|  |                    | FAD="H" at f <sub>OSC</sub> = 4.096MHz   | —    | —    | 10   | ms   |

\*1 Applies when inputting commands except the timings after PUP, PDWN, PLAY, or START command is input.

\*2 Applies when inputting PLAY, START, MUON command.

\*3 Applies when inputting STOP command.

● AC Characteristics (Clock Synchronous Serial Interface)

SPV<sub>DD</sub>=SPOV<sub>DD</sub>≥DV<sub>DD</sub>=IOV<sub>DD</sub>=2.7 to 5.5V, DGND=SPGND=SPOGND=0V, Ta=-40 to +105°C, Load capacitance of output pin =15pF(Max.)

| Parameter                                    | Symbol             | Condition | Min. | Typ. | Max. | Unit |
|--|--------------------|-----------|------|------|------|------|
| CSB input enable time from IRON falling edge | t <sub>EIRON</sub> | —         | 1000 | —    | —    | ns   |
| CSB hold time from IRON rising edge          | t <sub>IRONH</sub> | —         | 1000 | —    | —    | ns   |
| SCK setup time from CSB falling edge         | t <sub>SCKS</sub>  | —         | 100  | —    | —    | ns   |
| SCK input enable time from CSB falling edge  | t <sub>ESCK</sub>  | —         | 100  | —    | —    | ns   |
| SCK hold time from CSB rising edge           | t <sub>CSH</sub>   | —         | 100  | —    | —    | ns   |
| Data floating time from CSB rising edge      | t <sub>DOZ</sub>   | RL=3KΩ    | —    | —    | 100  | ns   |
| Data setup time from SCK                     | t <sub>DIS</sub>   | —         | 50   | —    | —    | ns   |
| Data hold time from SCK                      | t <sub>DIH</sub>   | —         | 50   | —    | —    | ns   |
| Data output delay time from SCK              | t <sub>DOD</sub>   | —         | —    | —    | 90   | ns   |
| SCK "H" level pulse width                    | t <sub>SCKH</sub>  | —         | 100  | —    | —    | ns   |
| SCK "L" level pulse width                    | t <sub>SCKL</sub>  | —         | 100  | —    | —    | ns   |
| CBUSYB output delay time from SCK            | t <sub>DBSY</sub>  | —         | —    | —    | 90   | ns   |

<When rewriting the flash memory using the clock synchronous serial interface>

SPV<sub>DD</sub>=SPOV<sub>DD</sub>≥DV<sub>DD</sub>=IOV<sub>DD</sub>=2.7 to 5.5V, DGND=SPGND=SPOGND=0V, Ta=-40 to +105°C, Load capacitance of output pin =15pF(Max.)

| Parameter                                    | Symbol             | Condition | Min. | Typ. | Max. | Unit |
|--|--------------------|-----------|------|------|------|------|
| CSB input enable time from IRON falling edge | t <sub>EIRON</sub> | —         | 1000 | —    | —    | ns   |
| CSB hold time from IRON rising edge          | t <sub>IRONH</sub> | —         | 1000 | —    | —    | ns   |
| SCK setup time from CSB falling edge         | t <sub>SCKS</sub>  | —         | 125  | —    | —    | ns   |
| SCK input enable time from CSB falling edge  | t <sub>ESCK</sub>  | —         | 125  | —    | —    | ns   |
| SCK hold time from CSB rising edge           | t <sub>CSH</sub>   | —         | 125  | —    | —    | ns   |
| Data floating time from CSB rising edge      | t <sub>DOZ</sub>   | RL=3KΩ    | —    | —    | 125  | ns   |
| Data setup time from SCK                     | t <sub>DIS</sub>   | —         | 50   | —    | —    | ns   |
| Data hold time from SCK                      | t <sub>DIH</sub>   | —         | 50   | —    | —    | ns   |
| Data output delay time from SCK              | t <sub>DOD</sub>   | —         | —    | —    | 110  | ns   |
| SCK "H" level pulse width                    | t <sub>SCKH</sub>  | —         | 125  | —    | —    | ns   |
| SCK "L" level pulse width                    | t <sub>SCKL</sub>  | —         | 125  | —    | —    | ns   |



● AC Characteristics (I<sup>2</sup>C Interface:Fast Mode 400kHz)

SPV<sub>DD</sub>=SPOV<sub>DD</sub>≥DV<sub>DD</sub>=IOV<sub>DD</sub>=2.7 to 5.5V, DGND=SPGND=SPOGND=0V, Ta=-40 to +105°C, Load capacitance of output pin =15pF(Max.)

| Parameter                               | Symbol              | Min | Max. | Unit |
|---|---------------------|-----|------|------|
| SCL clock frequency                     | t <sub>SCL</sub>    | 0   | 400  | kHz  |
| SCL hold time (start/restart condition) | t <sub>HD;STA</sub> | 0.6 | —    | μs   |
| SCL clock "L" level time                | t <sub>LOW</sub>    | 1.3 | —    | μs   |
| SCL clock "H" level time                | t <sub>HIGH</sub>   | 0.6 | —    | μs   |
| SCL setup time (restart condition)      | t <sub>SU;STA</sub> | 0.6 | —    | μs   |
| SDA hold time                           | t <sub>HD;DAT</sub> | 0   | —    | μs   |
| SDA setup time                          | t <sub>SU;DAT</sub> | 0.1 | —    | μs   |
| SDA setup time (stop condition)         | t <sub>SU;STO</sub> | 0.6 | —    | μs   |
| Bus free time                           | t <sub>BUF</sub>    | 1.3 | —    | μs   |
| Capacitive load on each bus line        | C <sub>b</sub>      | —   | 400  | pF   |

● AC Characteristics (SAI Interface (Slave))

SPV<sub>DD</sub>=SPOV<sub>DD</sub>≥DV<sub>DD</sub>=IOV<sub>DD</sub>=2.7 to 5.5V, DGND=SPGND=SPOGND=0V, Ta=-40 to +105°C, Load capacitance of output pin =15pF(Max.)

| Parameter             | Symbol    | Condition | Min. | Typ. | Max. | Unit |
|-----------------------|-----------|-----------|------|------|------|------|
| SAI_BCLK period       | tC_BCLK   | —         | 32fs | —    | 64fs | Hz   |
| SAI_BCLK "H" period   | tHW_BCLK  | —         | 100  | —    | —    | ns   |
| SAI_BCLK "L" period   | tLW_BCLK  | —         | 100  | —    | —    | ns   |
| SAI_LRCLK hold time   | tH_LRCLK  | —         | 80   | —    | —    | ns   |
| SAI_LRCLK setup time  | tSU_LRCLK | —         | 80   | —    | —    | ns   |
| SAI_SDOOUT delay time | tD_SDO *1 | —         | —    | —    | 80   | ns   |
| SAI_SDIN setup time   | tSU_SDI   | —         | 20   | —    | —    | ns   |
| SAI_SDIN hold time    | tH_SDI    | —         | 20   | —    | —    | ns   |

\*1 tD\_SDO is the time based on the slower change of SAI\_BCLK or SAI\_LRCLK.

● AC Characteristics (Flash Memory Interface)

SPV<sub>DD</sub>=SPOV<sub>DD</sub>≥DV<sub>DD</sub>=IOV<sub>DD</sub>=2.7 to 5.5V, DGND=SPGND=SPOGND=0V, Ta=-40 to +105°C, Load capacitance of output pin =15pF(Max.)

| Parameter                                 | Symbol             | Condition | Min. | Typ. | Max. | Unit |
|---|--------------------|-----------|------|------|------|------|
| IRCSB enable time from IRON falling edge  | t <sub>EIRON</sub> | —         | 1000 | —    | —    | ns   |
| IRCSB hold time from IRON rising edge     | t <sub>IRONH</sub> | —         | 1000 | —    | —    | ns   |
| IRSCK enable time from IRCSB falling edge | t <sub>ICSS</sub>  | —         | 100  | —    | —    | ns   |
| IRSCK hold time from IRCSB rising edge    | t <sub>ICSH</sub>  | —         | 100  | —    | —    | ns   |
| Data setup time from IRSCK rising edge    | t <sub>DIS</sub>   | —         | 50   | —    | —    | ns   |
| Data hold time from IRSCK rising edge     | t <sub>DIH</sub>   | —         | 50   | —    | —    | ns   |
| Data delay time from IRSCK falling edge   | t <sub>IDOD</sub>  | —         | —    | —    | 80   | ns   |
| IRSCK frequency                           | t <sub>ISCKF</sub> | —         | —    | —    | 5    | MHz  |
| IRSCK "H" level pulse width               | t <sub>ISCKH</sub> | —         | 100  | —    | —    | ns   |
| IRSCK "L" level pulse width               | t <sub>ISCKL</sub> | —         | 100  | —    | —    | ns   |
| IRSO delay time from IRON rising edge     | t <sub>IFLH</sub>  | —         | —    | —    | 1    | ms   |
| IRSO delay time from IRON falling edge    | t <sub>IFHL</sub>  | —         | —    | —    | 1    | ms   |

■ Block diagram

The block diagram is shown below.

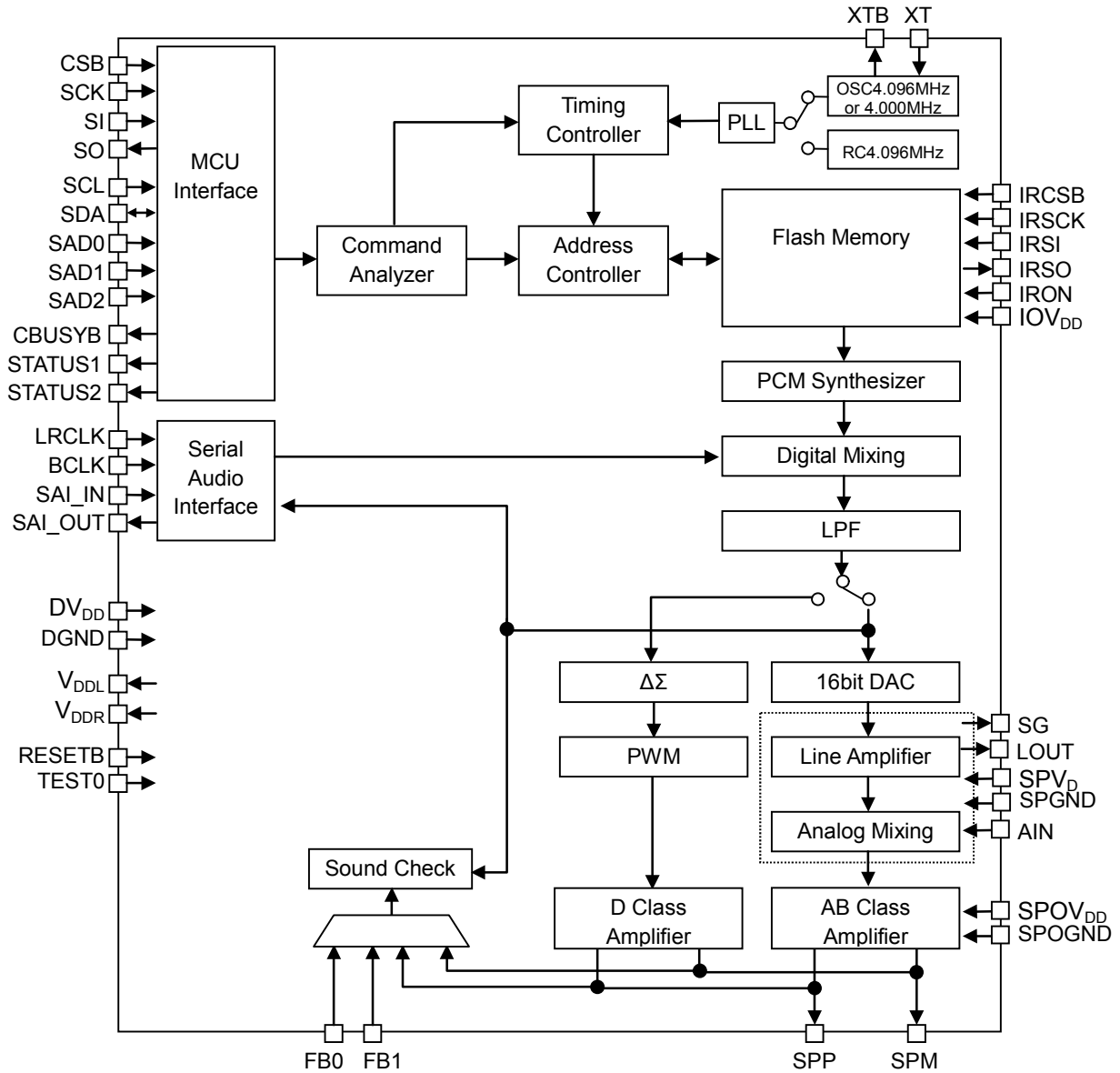

■ Function description

● Clock Synchronous Serial Interface

The CSB, SCK, SI, and SO pins are used to input various command data and to read the status.

For command and data inputting, after "L" level is input to the CSB pin, data is input to the SI pin in MSB first in synchronization with the input clock signal of the SCK pin. The SI pin data is loaded into the LSI in synchronization with the SCK pin clock, and the command data is determined by the SCK pin clock of the eighth pulse.

When reading, after "L" level is input to the CSB pin, it is output from the SO pin in synchronization with the input clock signal of the SCK pin.

The selection of the rising or falling edge of the SCK pin clock depends on the state of the SCK pin at the falling edge of the CSB pin.

When the SCK pin is "H" at the falling edge of the CSB pin, the SI pin data is loaded into the LSI on the rising edge of the SCK pin clock, and the status signal is output from the SO pin on the falling edge of the SCK pin clock.

When the SCK pin is "L" at the falling edge of the CSB pin, the SI pin data is loaded into the LSI on the falling edge of the SCK pin clock, and the status signal is output from the SO pin on the rising edge of the SCK pin clock.

When the CSB pin is fixed to "L" level, the SI pin data is loaded into the LSI on the rising edge of the SCK pin clock, and the status signal is output from the SO pin at the falling edge of the SCK pin clock.

However, if unexpected pulses are input to the SCK pin due to noise, etc., the count of the number of SCK pin clocks may be shifted, and normal command input may not be performed.

The serial interface can be returned to the initial state by setting the CSB pin to "H" level.

When the CSB pin is "H" level, the SO pin becomes a high impedance state.

Accessing with I<sup>2</sup>C slave interface at the same time is prohibited.

Command data input timing: SCK rising edge operation  
(When the SCK is "H" at the falling edge of the CSB)

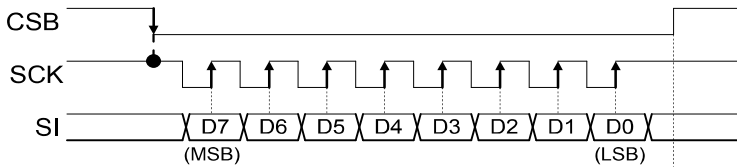

Command data input timing: SCK falling edge operation  
(When the SCK is "L" at the falling edge of the CSB)

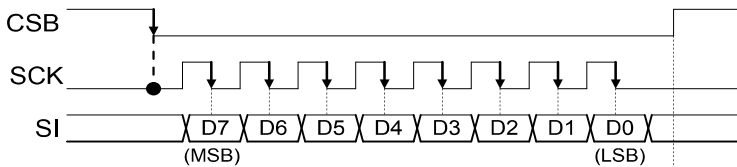

Command data output timing: SCK falling edge operation  
(When the SCK is "H" at the falling edge of the CSB)

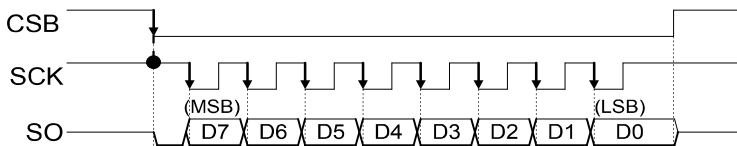

Command data output timing: SCK rising edge operation  
(When the SCK is "L" at the falling edge of the CSB)

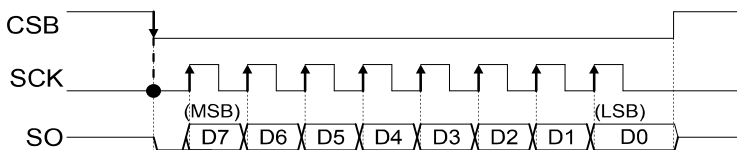

● I<sup>2</sup>C Interface (Slave)

This serial interface conforms to the I<sup>2</sup>C bus specifications. It supports Fast modes and can transmit and receive data at 400kbit/s. The SCL and SDA pins are used to input various command data and to read the status. The slave addresses are set by the SAD0 to 2 pins.

When I<sup>2</sup>C is used, be sure to insert a pull-up resistor between SCL and SDA pins and DV<sub>DD</sub> pin.

In the communication flow between the master and this device (slave) on the I<sup>2</sup>C bus, after the start condition is set, the slave address (upper 3 bits of the slave address are set by the SAD0 to 2 pins) is entered in the first 7 bits, the data direction is determined in the 8th bit (when the 8th bit is "0", data is written from the master, and data is read from the master when "1") and communication is performed in byte units thereafter. At this time, acknowledgment is required for each byte.

Accessing with clock synchronous serial interface at the same time is prohibited.

The I<sup>2</sup>C communication flow/timing chart is shown below.

◆ Command flow when writing data (1-byte command)

- Start condition
- Slave address +W(0)
- Write data (ex. Command 1st byte)
- Stop condition

- Timing chart when writing data. (1 byte command)

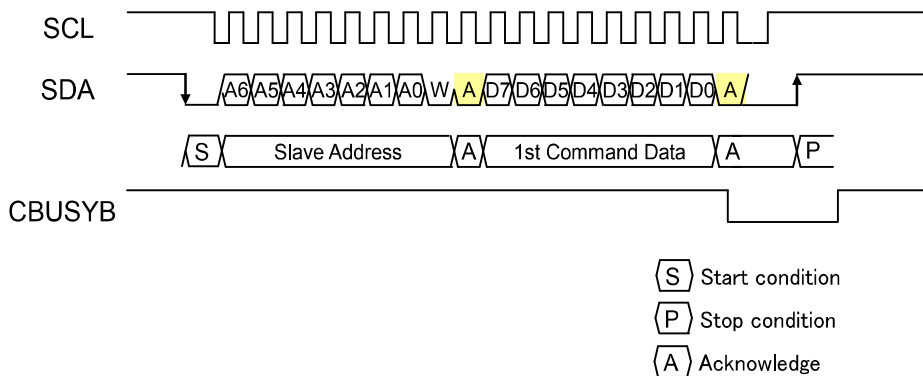

◆ Command flow when writing data (2-byte command)

- Start condition
- Slave address +W(0)
- Write data (ex. Command 1st byte)
- Write data (ex. Command 2nd byte)
- Stop condition

- Timing chart when writing data. (2 byte command)

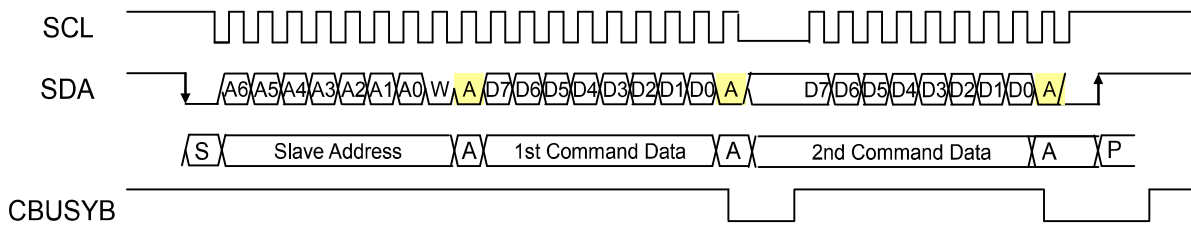

◆ Command flow when writing data (3-byte command)

- Start condition
- Slave address +W(0)
- Write data (ex. Command 1st byte)
- Write data (ex. Command 2nd byte)
- Write data (ex. Command 3rd byte)
- Stop condition

- Timing chart when writing data. (3 byte command)

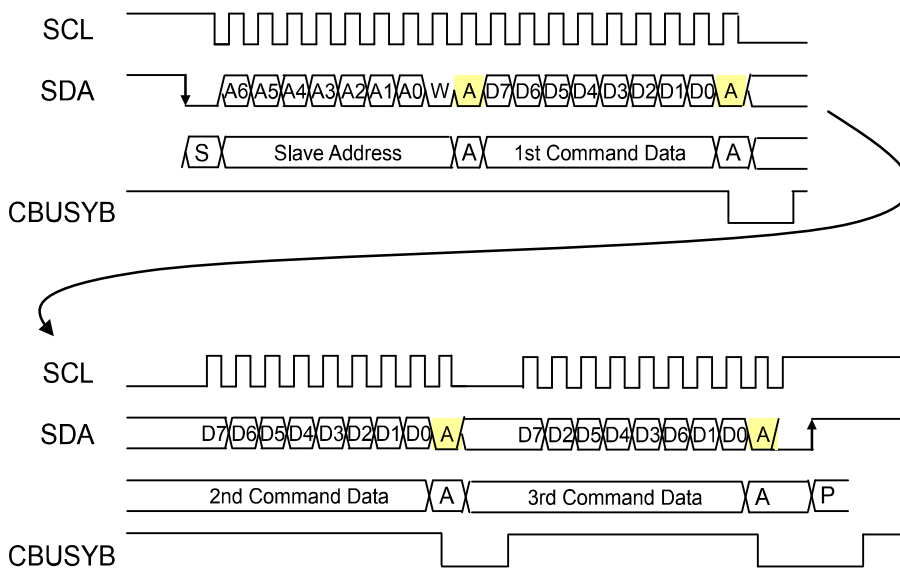

◆ Command flow when reading data

Start condition  
 Slave address +W(0)  
 RDSTAT Command  
 Stop condition

Start condition  
 Slave address + R(1)  
 Read data (ex. Status read)  
 Stop condition

- Timing chart when reading data.

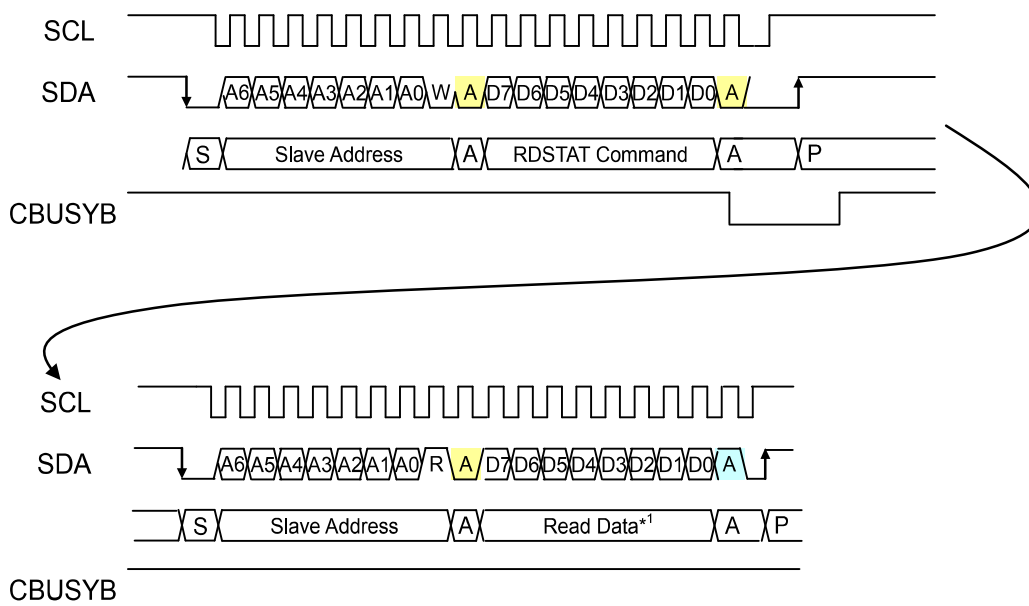

\*1 When the two-time input mode, the error state reading is 2 bytes

The data read flow is used when data is read by RDSTAT/RDERR/RDVER commands. The data to be read is updated by inputting RDSTAT/RDERR/RDVER command. Be sure to enter the RDSTAT/RDERR/RDVER command before reading the internal status.

The slave address can be set as follows using the SAD2 to SAD0 pins.

| SAD2 | SAD1 | SAD0 | Lower 4 bits | Slave address |
|------|------|------|--------------|---------------|
| 0    | 0    | 0    | 0101         | 000_0101      |
| 0    | 0    | 1    | 0101         | 001_0101      |
| 0    | 1    | 0    | 0101         | 010_0101      |
| 0    | 1    | 1    | 0101         | 011_0101      |
| 1    | 0    | 0    | 0101         | 100_0101      |
| 1    | 0    | 1    | 0101         | 101_0101      |
| 1    | 1    | 0    | 0101         | 110_0101      |
| 1    | 1    | 1    | 0101         | 111_0101      |



● SAI (Serial Audio Interface)

SAI transfers digital sound data serially.

The sound data input from the SAI\_IN pin can be played using the speaker amplifier or LINE amplifier.

Furthermore, not only can it be mixed with the sound data in the flash memory and played back by the speaker amplifier or LINE amplifier, but it can also be output from SAI\_OUT pin.

Various serial data formats are supported by a combination of command settings.

A WSLI, DLYI and MSBI are used to represent the supported formats.

For WSLI, DLYI and MSBI, refer to the "SAIRCON command".

When using SAI, set the analog power-up state with the AMODE command.

<DLYI="0", ISSCKI="0" / DLYO="0", ISSCKO="0", MSBI="0">

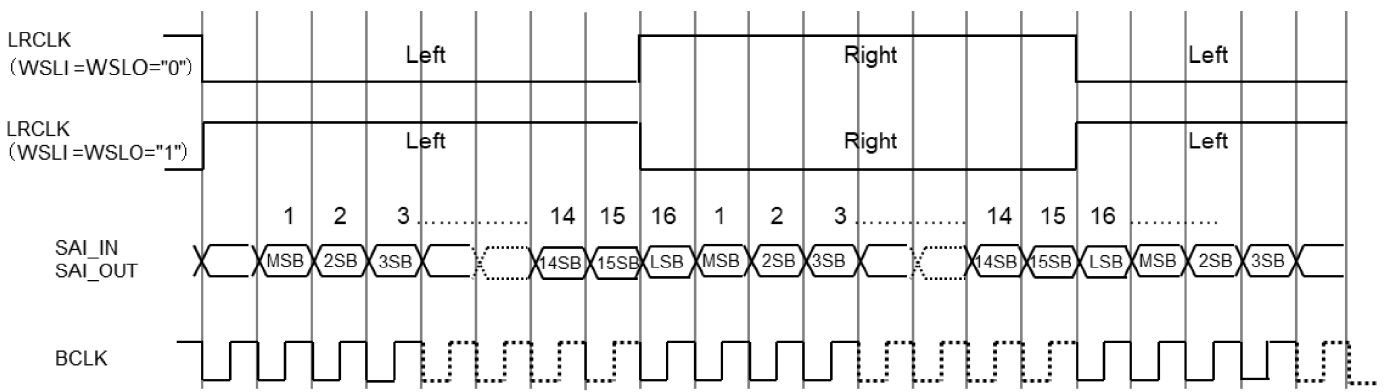

<DLYI="0", ISSCKI="1" / DLYO="0", ISSCKO="1", MSBI="0">

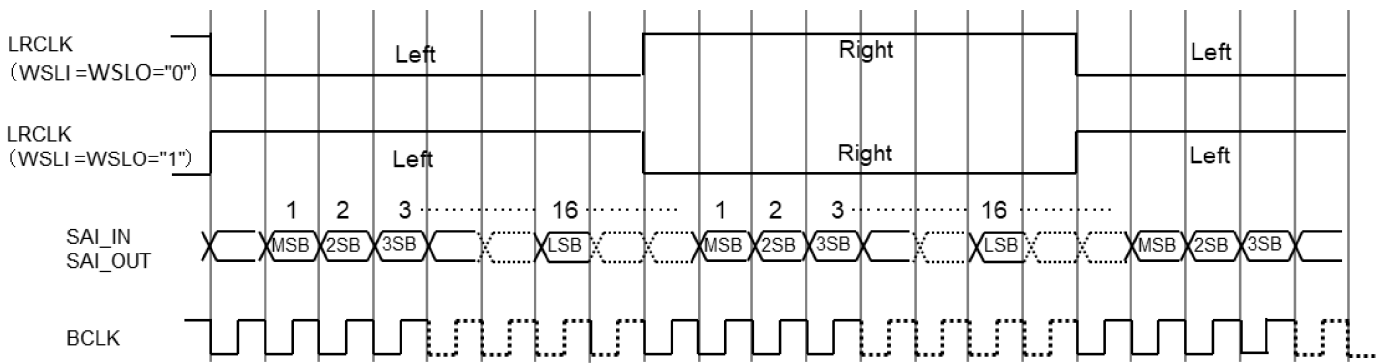

<DLYI="1", ISSCKI="1" / DLYO="1", ISSCKO="1", MSBI="0">

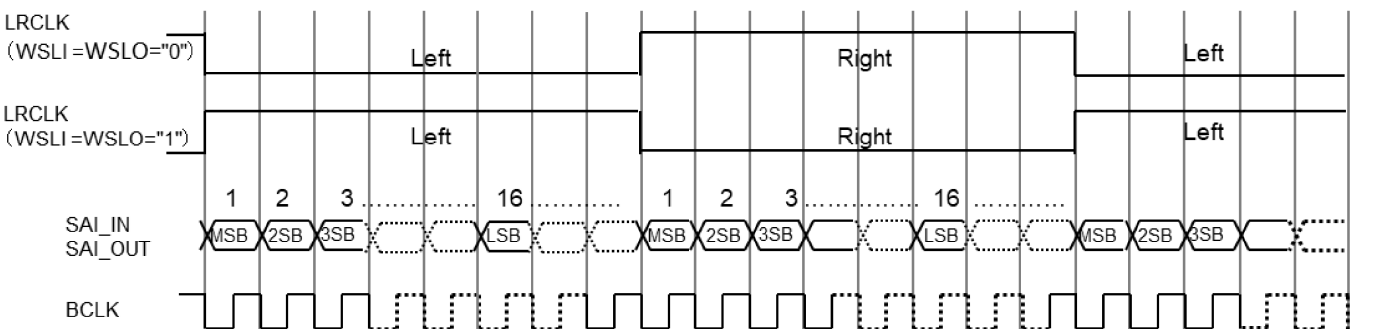

<DLYI="0", ISSCKI="0" / DLYO="0", ISSCKO="0", MSBI="1">

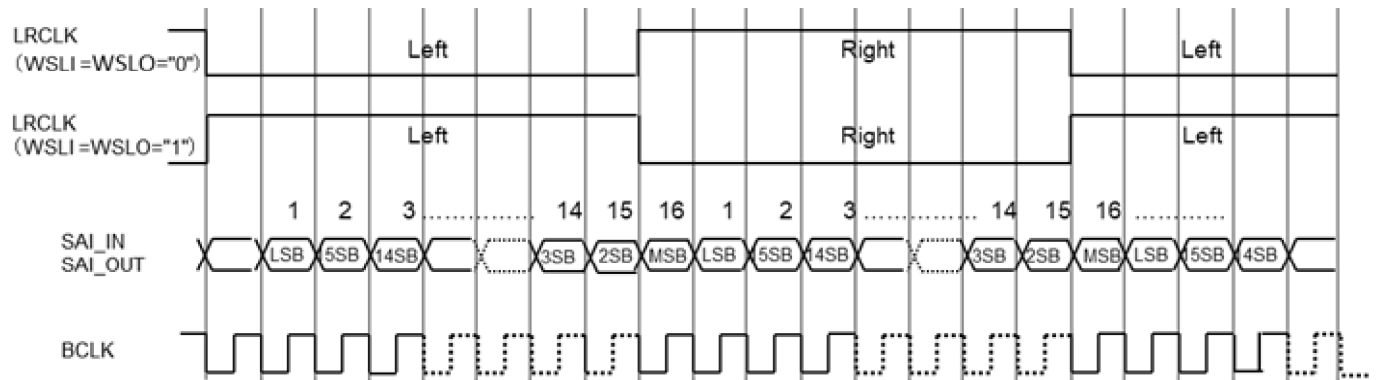

● Volume Settings (Differences Between AVOL and CVOL and PAN)

The volume can be set with four commands CVOL, PAN, AVOL and AMODE.

The CVOL can set the volume of each channel, the PAN can set the volume of each channel (Lch/Rch) output to the SAI\_OUT pin, the AVOL can set the volume after channel mixing, and the AMODE can set the input gain to the amplifier. By using the fade function with FADE command, the volume can be adjusted stepwise when the volume is changed with CVOL and PAN.

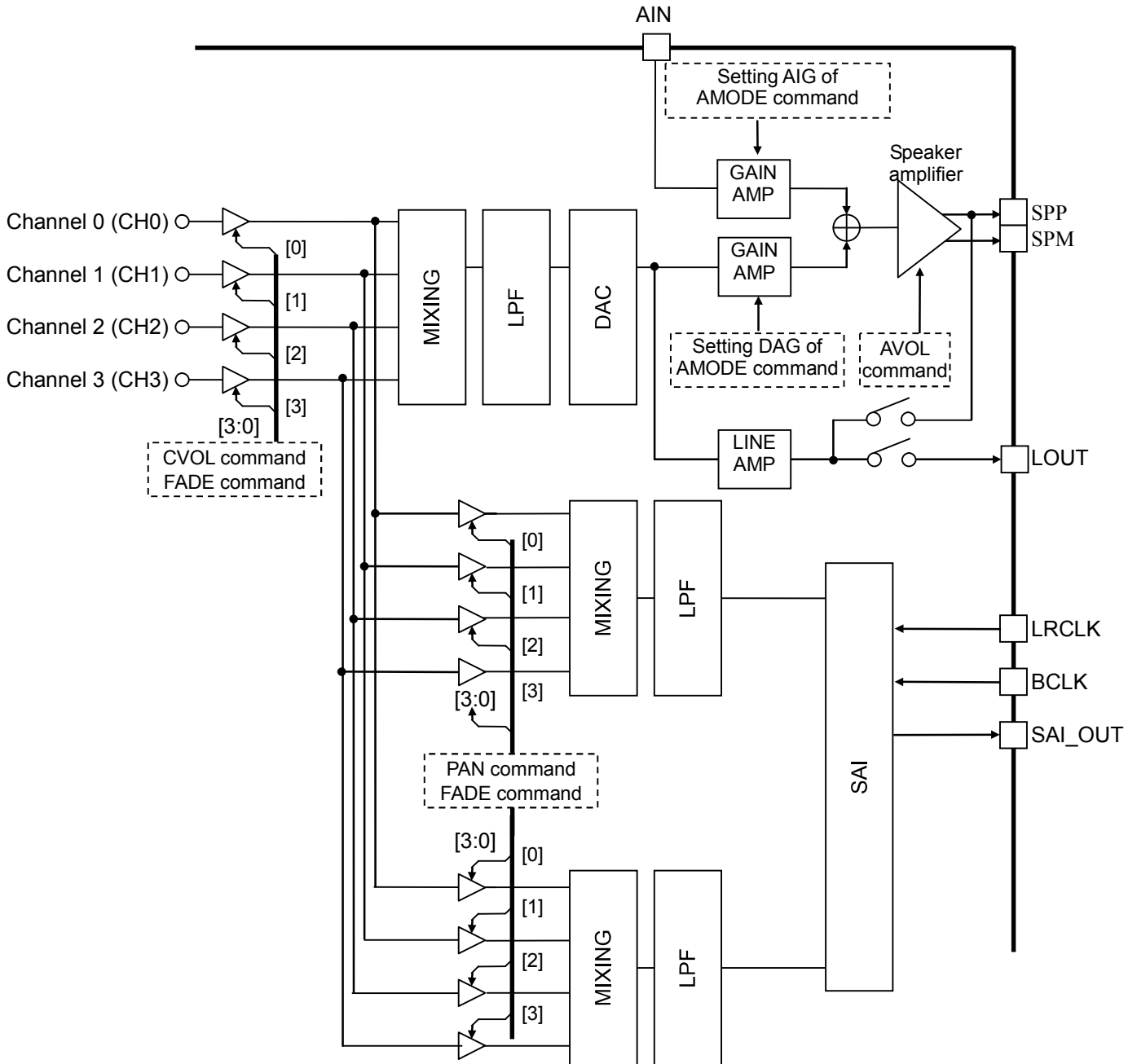

● Speech synthesis algorithm

This LSI contains five algorithm types to match the characteristic of playback sound: 4-bit ADPCM2 algorithm, HQ-ADPCM algorithm, 8-bit non-linear PCM algorithm, 8-bit straight PCM algorithm, and 16-bit straight PCM algorithm. Key feature of each algorithm is described in the table below.

| Speech synthesis algorithm | Compression rate *1 | Feature  |
|----------------------------|---------------------|--|
| HQ- ADPCM                  | 1/5                 | 4bit ADPCM algorithm is improved. Adopting variable bit length enables high sound quality and high data compression. Suitable for sound effects with sharp changes in waveforms or for pulsed waveforms. |
| 4-bit ADPCM2               | 1/4                 | LAPIS original 4bit ADPCM algorithm is improved. Better followability to the waveform improves the sound quality. Suitable for human voices, animal crying, and natural sounds.                          |
| 8-bit non-linear PCM       | 1/2                 | This algorithm enables playing back a sound with 10-bit equivalent quality in the center of the waveform. Suitable for low-amplitude sounds that are easily distorted.                                   |
| 8-bit straight PCM         | 1/2                 | This algorithm has excellent followability to the waveform in all sound areas. Suitable for sound effects with sharp changes in waveforms or for pulsed waveforms.                                       |
| 16-bit straight PCM        | 1                   | This algorithm has excellent followability to the waveform in all sound areas. Suitable for sound effects with sharp changes in waveforms or for pulsed waveforms.                                       |

\*1: When using the same sampling frequency.

● Memory Allocation and Creating Sound Data

The flash memory is partitioned into four data areas: sound (i.e., phrase) control area, test area, sound area, and edit ROM area.

The sound control area manages the sound data in the ROM. It contains data for controlling the start/stop addresses of sound data for 4,096 phrases, use/non-use of the edit ROM function and so on.

The test area contains data for testing.

The sound area contains actual waveform data.

The edit ROM area contains data for effective use of sound data. For the details, refer to the section of "Edit ROM Function".

The edit ROM area is not available if the edit ROM is not used.

The Sound data is created using a dedicated tool (Speech LSI Utility).

Configuration of Flash Memory Data (4Mbit)

|         |  |
|---------|--|
| 0x00000 | Test area  |
| 0x0007F |  |
| 0x00080 | Sound control area (*)<br>(The number of phrases can be set with the dedicated tools.) |
| 0x0207F |  |
| 0x02080 | Sound area   |
| 0x7FFFF |  |
|         | -----<br>Edit ROM area<br>Depends on creation of sound data.                           |

(\*) When the number of phrases is set to 1024  
The number of phrases can be set from 1024 to 4096 in 1024 units using the dedicated tools.

● Playback time and memory capacity

The playback time depends on the number of phrases, memory capacity, sampling frequency, and playback algorithm. The relationship is shown below. However, this is the playback time when the edit ROM function is not used.

$$\text{Playback Time} = \frac{1.024 \times (\text{Memory Capacity (kbit)} - (0.0625 \times \text{Number of Phrases}) - 0.625)}{\text{Sampling frequency (kHz)} \times \text{bit length}} \quad (\text{sec})$$

When the number of phrases is 1024, the sampling frequency is 16kHz, and the HQ-ADPCM algorithm is selected, the playback time will be approximately 81 seconds.

$$\text{Playback Time} = \frac{1.024 \times (4096(\text{kbit}) - (0.0625 \times 1024) - 0.625)}{16 (\text{kHz}) \times 3.2 (\text{bit}) (\text{average})} \doteq 81 (\text{sec})$$

● Edit ROM Function

With the edit ROM function, multiple phrases can be played in succession. The following functions can be configured using the edit ROM function:

- Continuous playback: There is no limit to the continuous playback count that can be specified. It depends on the memory capacity only.
- Silence insertion: 20 to 1024 ms

Using the edit ROM function enables an effective use of the flash memory capacity. Below is an example of the ROM configuration in the case of using the edit ROM function.

Examples of Phrases Using the Edit ROM Function

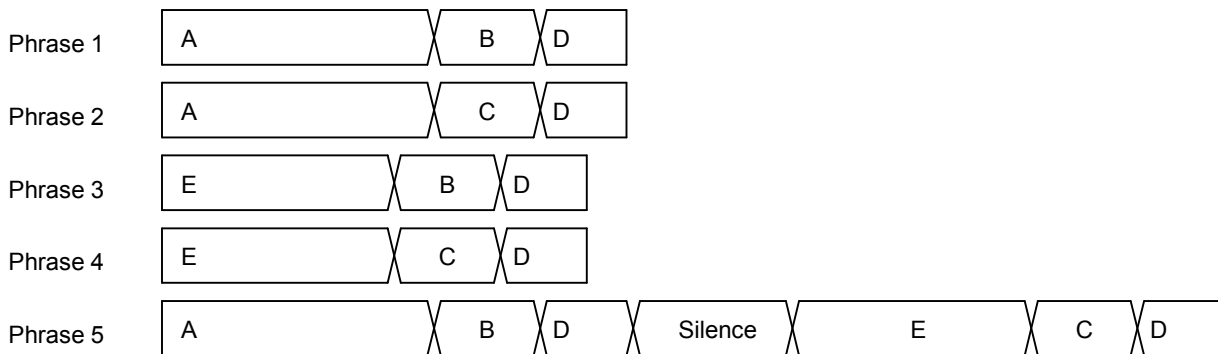

Example of Sound data Where the Contents Above Are Stored in ROM

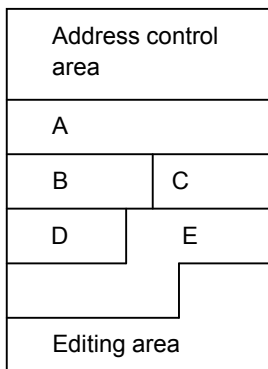

● Mixing function

Up to 4 channels mixing playback is possible at the same time. Commands with channel designation can set channels independently.

◆ Restrictions when using Serial Audio Interface(SAI).

When the serial audio interface (SAI) is not used, there is no limitation to the maximum number of mixing in each speech synthesis algorithm.

<When the serial audio interface (SAI) is not used>

| Sampling frequency (kHz) | Speech synthesis algorithm | Maximum mixing number | Playable channels<br>(○: Playable/×: Not playable) |     |     |     |
|--------------------------|----------------------------|-----------------------|--|-----|-----|-----|
|                          |                            |                       | CH0  | CH1 | CH2 | CH3 |
| All sampling frequency   | 4-bit ADPCM2               | 4                     | ○  | ○   | ○   | ○   |
|                          | HQ-ADPCM                   |                       |  |     |     |     |
|                          | 8-bit non-linear PCM       |                       |  |     |     |     |
|                          | 8-bit straight PCM         |                       |  |     |     |     |
|                          | 16-bit straight PCM        |                       |  |     |     |     |

When the serial audio interface (SAI) is used, there are some limitations to the maximum number of mixing and playable channels depending on the sampling frequency.

<When the serial audio interface (SAI) is used>

| Sampling frequency (kHz)            | Speech synthesis algorithm | Maximum mixing number | Playable channels<br>(○: Playable/×: Not playable) |     |     |     |
|-------------------------------------|----------------------------|-----------------------|--|-----|-----|-----|
|                                     |                            |                       | CH0  | CH1 | CH2 | CH3 |
| 12.0/24.0/48.0<br>11.025/22.05/44.1 | 4-bit ADPCM2               | 3*2                   | ○  | ○   | ○   | ×   |
|                                     | HQ-ADPCM                   |                       | ○  | ○   | ○   | ×   |
|                                     | 8-bit non-linear PCM       |                       | ○  | ○   | ○   | ×   |
|                                     | 8-bit straight PCM         |                       | ○  | ○   | ○   | ×   |
|                                     | 16-bit straight PCM        | ○                     | ○  | ○   | ×   |     |
|                                     | SAI*1                      | 2                     | ○  | ○   | ○   | ×   |
| 8.0/16.0/32.0                       | 4-bit ADPCM2               | 4*3                   | ○  | ○   | ○   | ○   |
|                                     | HQ-ADPCM                   |                       | ×  | ×   | ×   | ×   |
|                                     | 8-bit non-linear PCM       |                       | ○  | ○   | ○   | ○   |
|                                     | 8-bit straight PCM         |                       | ○  | ○   | ○   | ○   |
|                                     | 16-bit straight PCM        | ○                     | ○  | ○   | ○   |     |
|                                     | SAI*1                      | 2                     | ○  | ○   | ○   | ○   |

\*1 When both Lch and Rch are used by SAI, two channels are used by SAI. When only one of Lch or Rch is used, one channel is used for SAI.

\*2 When two channels are used in SAI, one channel can be used, and when one channel is used in SAI, two channels can be used.

\*3 When two channels are used in SAI, two channels can be used, and when one channel is used in SAI, three channels can be used.

When mixing at the sampling frequencies of 8.0/16.0/32.0kHz with using Serial Audio Interface(SAI), HQ-ADPCM cannot be used.

◆ Waveform clamp precautions for mixing

When mixing, the clamp may be generated as shown in the figure below due to the calculation of the synthesis. If the clamp is known to be generated in advance, adjust the volume of each channel by CVOL and PAN commands.

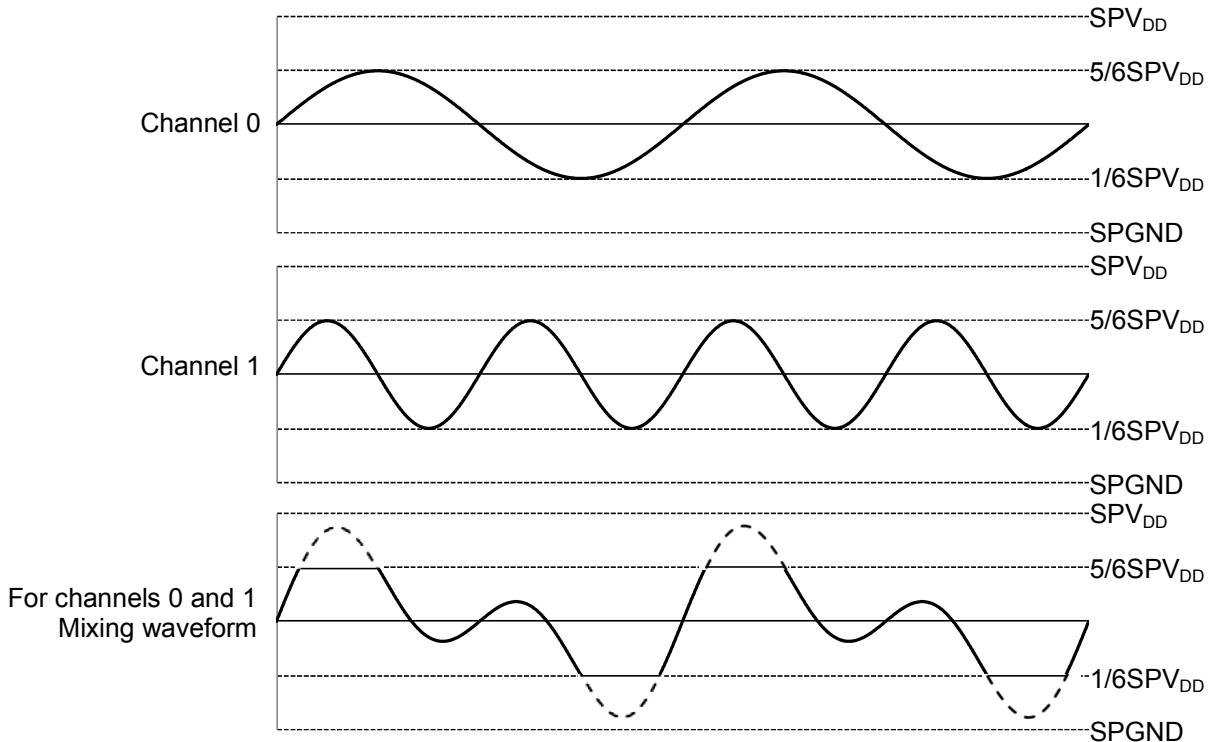

If the result of mixing channels 0 and 1 exceeds from the  $1/6SPV_{DD}$  to  $5/6SPV_{DD}$  level (as indicated by the broken line), the sound quality may be reduced by clamping. Waveforms when AVOL is set to 0.0dB.



◆ Different sampling frequency mixing algorithm

It is not possible to perform channel mixing by a different sampling frequency group.

Note that when channel synthesis is performed on a sampling frequency group other than the selected sampling frequency group, playback will be faster or slower. When either LEN or REN is set to "1" by the SAI (serial audio interface) SAICH command, the frequency is fixed to the frequency group of the SAI selected by the SAICON command.

The following table lists the frequency groups that can be used when mixing different sampling frequency groups.

|                              |               |
|------------------------------|---------------|
| 6.4kHz, 12.8kHz, 25.6kHz     | ... (Group 1) |
| 8.0kHz, 16.0kHz, 32.0kHz     | ... (Group 2) |
| 11.025kHz, 22.05kHz, 44.1kHz | ... (Group 3) |
| 12.0kHz, 24.0kHz, 48.0kHz    | ... (Group 4) |
| 10.7kHz, 21.3kHz             | ... (Group 5) |

The figure below shows the operation image when a sampling frequency group with different sampling frequency group is played back.

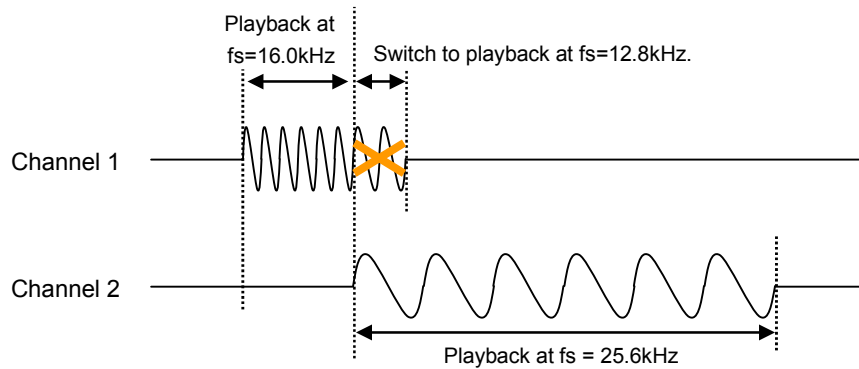

Figure 1) Case where a phrase is played at a sampling frequency belonging to a different sampling frequency group during playback on channels 1 and 2

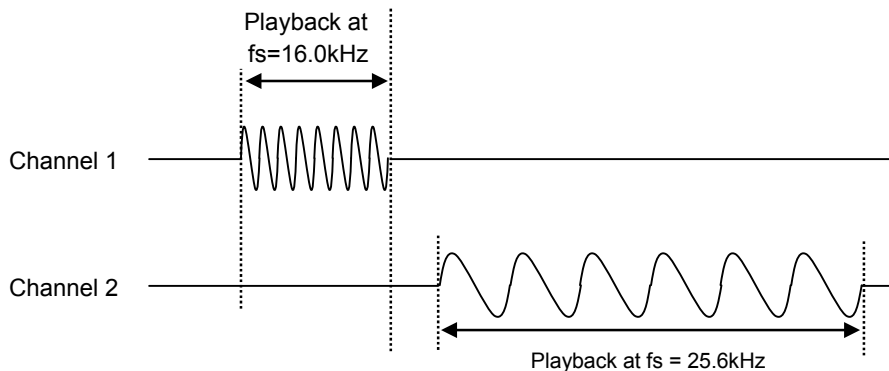

Figure 2) Case where a phrase is played at a sampling frequency belonging to a different sampling frequency group after playback is finished at the other channel

● Misoperation detection and failure detection functions

Misoperation detection and failure detection functions can be set with SAFE command. The error detection status can be read by the RDERR command, and the error bit indicating the error detection status can be cleared by the ERRCL command. In addition, OUTSTAT command can be used to send whether an error is detected or not to the STATUS1 pin or STATUS2 pin. For SAFE, RDERR, ERRCL and OUTSTAT commands, refer to the "Command" section.

Misoperation detection and failure detection are shown below.

- Command error detection
- Speaker disconnection detection
- LSI temperature error detection
- SPP pin and SPM pin short detection
- Flash memory error detection
- Watchdog timer overflow detection
- RST counter overflow detection
- Detects the stop of clock input from a crystal resonator or ceramic resonator.
- Detects disconnection/short-circuit of the BCLK.
- Detects disconnection/short-circuit of the LRCLK.
- Detects disconnection/short-circuit of the SAI\_IN.
- Mixing number error detection
- Playback sound error detection

◆ Command error detection

This LSI detects two command errors: phrase number error and command error. Use the WCMEN bit of the SAFE command to set command error detection.

① Phrase number error.

Set the number of phrases (1024, 2048, 3072 or 4096) to use when creating sound data in the Speech LSI Utility. If you specify a phrase that exceeds the number of phrases specified by the Speech LSI Utility with the PLAY2 or FADR2 command, an error in the command is detected and the error bit (WCMERR) is set to "1".

② Command error.

This LSI has a function to input various commands and data two-times to prevent malfunction due to noise at the serial interface pin. The setting of the two-times input mode is made at power-up. Refer to the "PUP command" for the setting method.

In the two-times input mode, the command data is input two-times in succession, and it is valid only when the input data matches. If a mismatch occurs during the second data input after the first data input, an error in the command is detected and the error bit (WCMERR) is set to "1", and the command entered is ignored.

Error bit (WCMERR) can be read with RDERR command. Also, error bit (WCMERR) can be cleared by ERRCL command.

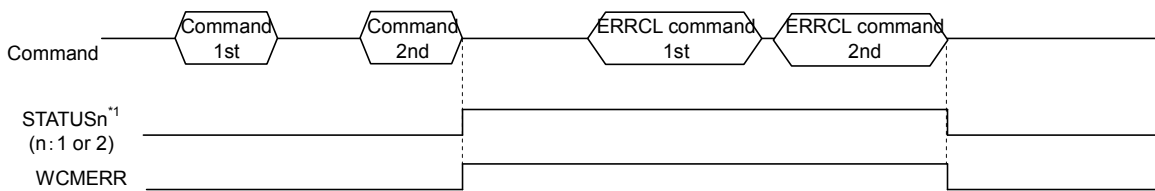

\*1 Misoperation detection and failure detection outputs are selected by OUTSTAT command.

◆ Speaker disconnection detection

Set the speaker disconnection detection with the DCDEN bit of the SAFE command.  
 The speaker connection status of the SPP and SPM pins is checked when the analog power-up is activated in speaker amplifier output mode by AMODE command. When the disconnection of the speaker is detected, the error bit (DCDERR) is set to "1".  
 Error bit (DCDERR) can be read with RDERR command. Also, error bit (DCDERR) can be cleared by ERRCL command.

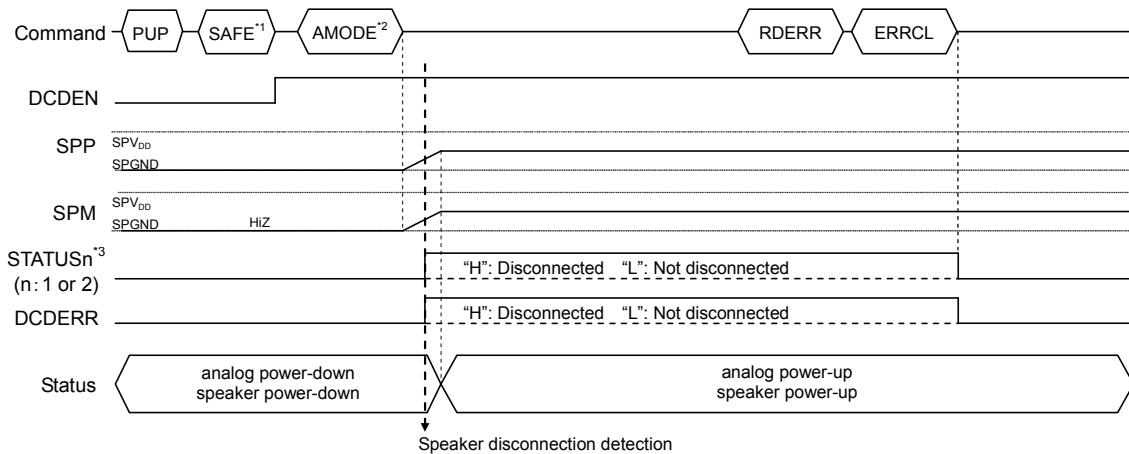

- \*1 Set DCDEN = "1"
- \*2 Analog power-up in speaker amplifier output mode
- \*3 Misoperation detection and failure detection outputs are selected by OUTSTAT command.

◆ LSI temperature error detection

Set the LSI temperature error detection with the TSDEN bit of the SAFE command.  
 When the TSDEN bit is set to "1" by the SAFE command, LSI temperature error detection starts. When the TSDEN bit is set to "0", LSI temperature error detection ends.  
 When the LSI becomes 130°C or more, the error bit (TSDERR) becomes "1".  
 Error bit (TSDERR) can be read with RDERR command. Also, error bit (TSDERR) can be cleared by ERRCL command.

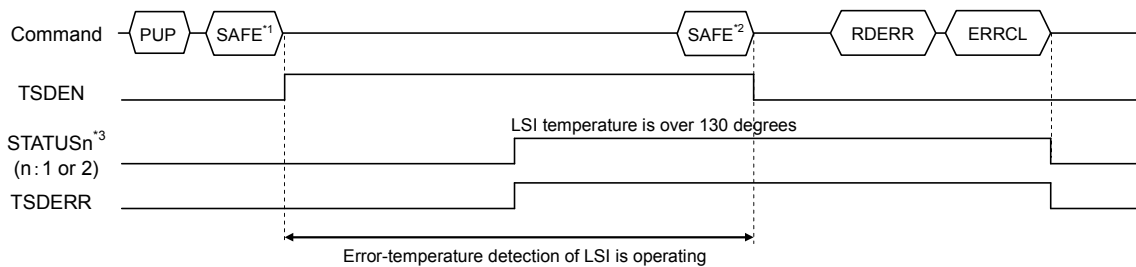

- \*1 Set TSDEN = "1"
- \*2 Set TSDEN = "0"
- \*3 Misoperation detection and failure detection outputs are selected by OUTSTAT command.

◆ SPP pin and SPM pin short detection

Set the SPP pin and SPM pin short detection with the SPDEN bit of the SAFE command.  
 Detects short circuit between SPP pin and SPM pin, or SPP pin and GND (ground fault), or SPM pin and GND (ground fault). Can be used when  $SPV_{DD} \geq 4.5V$ . Operation is started by analog power-up in the speaker amplifier output mode by the AMODE command, and operation is terminated by power-down in the speaker amplifier output mode by the AMODE command.

After inputting SAFE command, start the analog power-up operation by AMODE command within 10ms.

When a short-circuit is detected, the error bit (SPDERR) is set to "1". When using a class D amplifier with the DAMP bit of AMODE command set to "1", if the PWM output is fixed to "H" level for 62.5μs or longer, the error bit (SPDERR) is set to "1". At the same time, the speaker amplifier output pin (SPP/SPM) is forcibly turned off. Read the error bit (SPDERR) with the RDERR command, end playback, and perform analog power-down with the AMODE command. Then, use ERRCL command to clear the error bit (SPDERR).

To restart playback, use the AMODE command to analog power-up the speaker amplifier output mode and enter the PLAY command. However, if shorting to ground continues, the error bit (SPDERR) is set to "1" and the speaker amplifier output pin (SPP/SPM) is forcibly turned off simultaneously.

Short detection prevents damage to LSI. However, the detection circuit is effective in preventing damage due to unexpected accidents. It does not support continuous short operation or transient use.

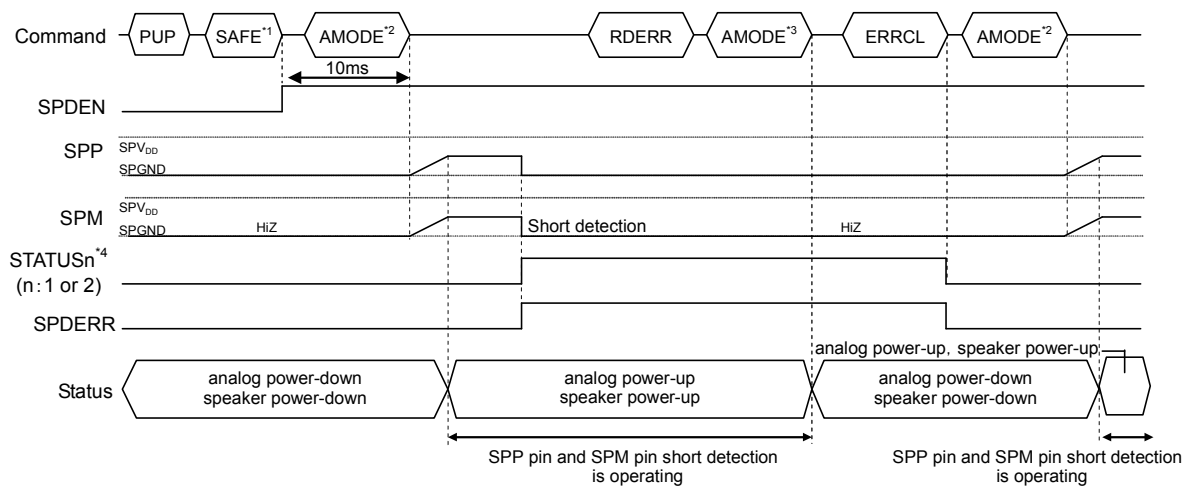

\*1 Set 1 SPDEN = "1"

\*2 Analog power-up in speaker amplifier output mode

\*3 Analog power-down in speaker amplifier output mode

\*4 Misoperation detection and failure detection outputs are selected by OUTSTAT command.

◆ Flash memory error detection

Set the Flash memory error detection with the ROMEN bit of the SAFE command. It is possible to detect two kinds of errors.

① Flash memory read data error

When an error is detected in the read data from the flash memory, the error bit (ROMERR) is set to "1". At the same time, playback of the corresponding channel is stopped.

If the error bit (ROMERR) is set to "1" after the PUP command and before the PLAY command or START command starts playback, this LSI may have error at the time of start. In such cases, initialize this LSI by moving the LSI to the power-down mode by resetting the LSI by the RESETB pin or by using PDWN command.

② Access outside the flash memory address range

If the flash memory is accessed outside the flash memory address range, an error is detected and the error bit (ROMERR) is set to "1".

At the same time, playback of the corresponding channel is stopped.

Error bit (ROMERR) can be read with RDERR command. Error bit (ROMERR) can be cleared by ERRCL command.

◆ Watchdog timer overflow detection

A communication error between the HOST MCU and this LSI (disconnection or short-circuit of the MCU command interface, etc.) can be detected.

Set the watchdog timer overflow detection with WDTEN bit of the SAFE command.

When the detection operation is started, the detection does not stop even if the WDTEN bit is set to "0".

After the detection operation starts, clear the WDT counter with the WDTCL command before the WDT counter overflows.

When the WDT counter overflows (for the first time), the error bit (WDTERR) is set to "1".

Error bit (WDTERR) can be read with RDERR command. In addition, the error bit (WDTERR) can be cleared by the ERRCL command after the WDTCL command.

The count time of the WDT counter is 2s the initial value. The counting time can be set to 125ms, 500ms, 2s, 4s. In addition, it is possible to shift to the command wait state after power-up by the second overflow of the WDT counter.

The count time and the second overflow operation can be set with the dedicated tools (Speech LSI Utility).

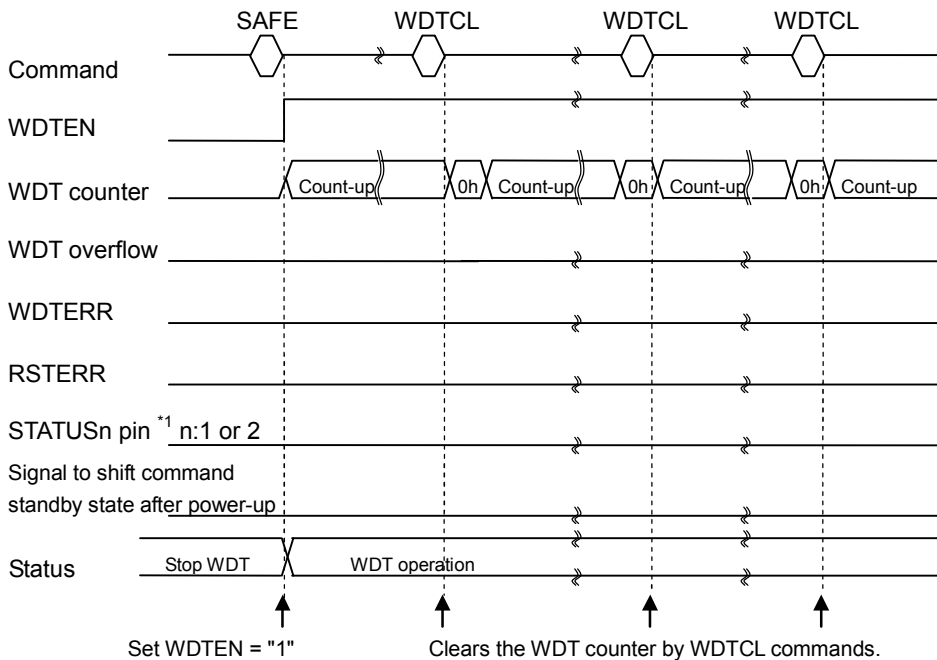

\*1 Misoperation detection and failure detection outputs are selected by OUTSTAT command.

Recommended Operation Flow of Watchdog Timer

The operation when no WDTCL command is entered is as follows.

< When "Transition to the command standby state after power-up" is selected by the second overflow of the WDT counter >

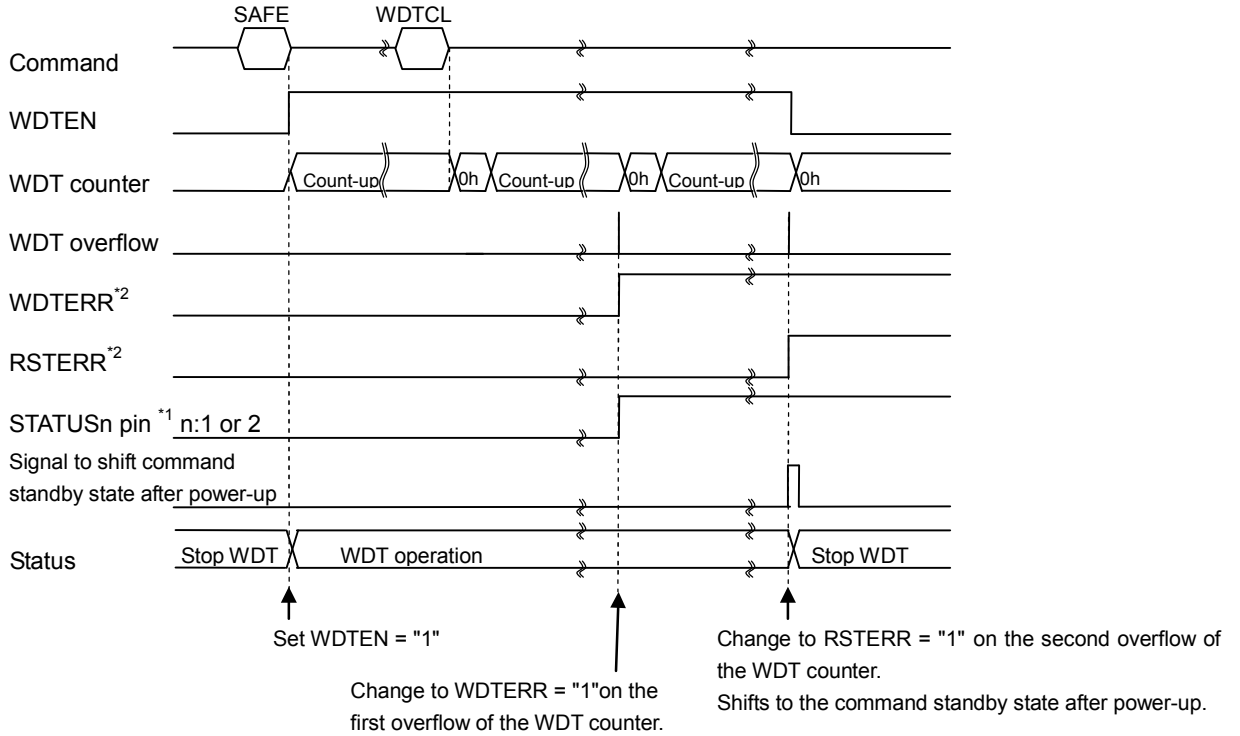

\*1 Misoperation detection and failure detection outputs are selected by OUTSTAT command.

\*2 Even if transferring to the command standby state after power-up by the second overflow of the WDT counter, the states of WDERR bit and RSTERR bit remain. The state configured by OUTSTAT command also remains.

< When "Transition to the command standby state after power-up" is not selected by the second overflow of the WDT counter >

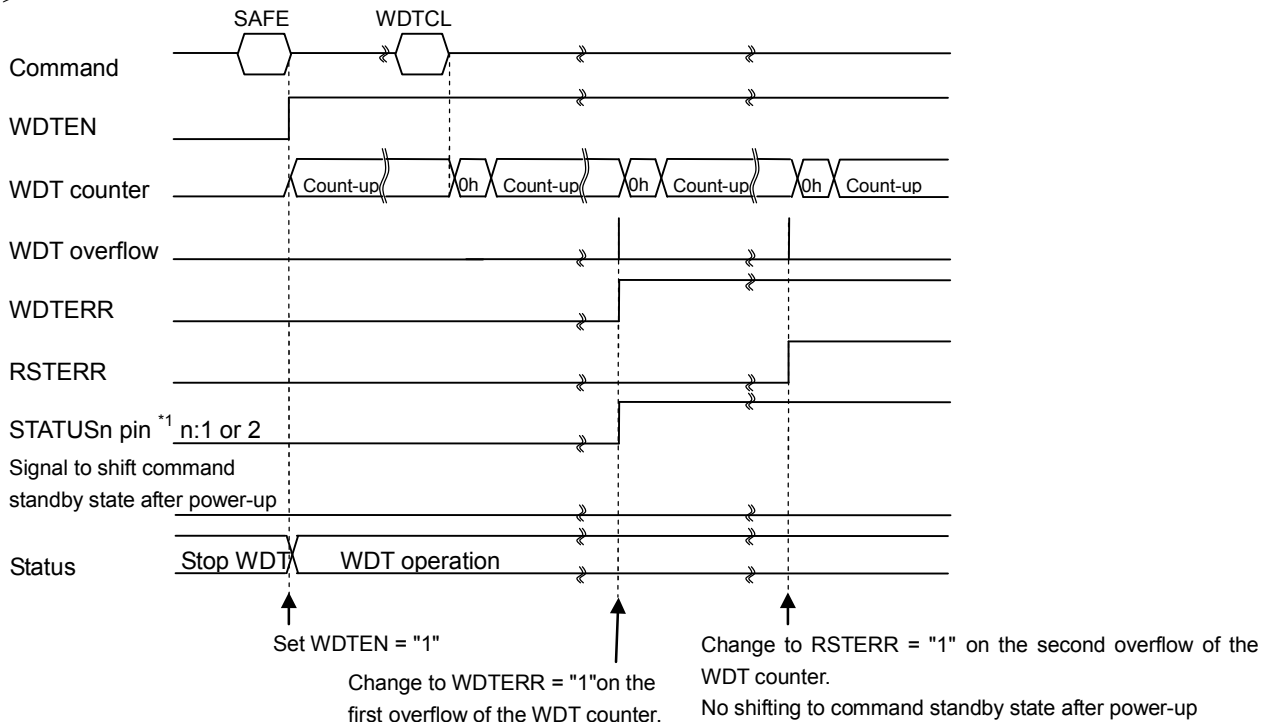

\*1 Misoperation detection and failure detection outputs are selected by OUTSTAT command.



◆ RST counter overflow detection

By using the RST counter overflow detection, it is possible to shift the LSI to the command standby state after power-up after misoperation detection and failure detection occurs.

When the overflow detection of RST counter is set by RSTEN bit of SAFE command, the detection operation will start.

When the detection operation is started, the detection does not stop even if the RSTEN bit is set to "0".

The RST counter starts counting up after misoperation detection and failure detection occurs.

If the RST counter is cleared with the ERRCL command before it overflows, it stops until the next error occurs.

When the RST counter overflows, the error bit (RSTERR) is set to "1".

Error bit (RSTERR) can be read with RDERR command. Also, error bit (RSTERR) can be cleared by ERRCL command.

The count time of the RST-counter is 2s, the initial-value. The counting time can be set to 125ms, 500ms, 2s, or 4s.

Set the counting time and overflow operation (shift to the command standby state after power-up) with the dedicated tools (Speech LSI Utility).

The operation when RSTEN is set to "1" is as follows.

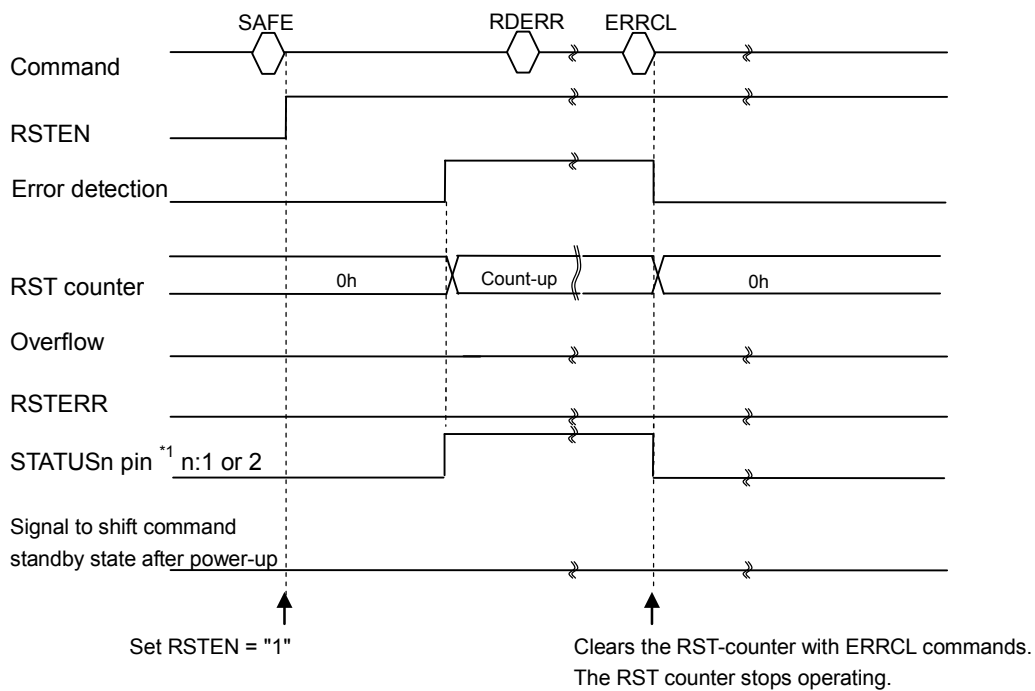

\*1 Misoperation detection and failure detection outputs are selected by OUTSTAT command.

The operation when no ERRCL command is entered is as follows.

< When "Transition to the command standby state after power-up" is selected by the overflow of the RST counter >

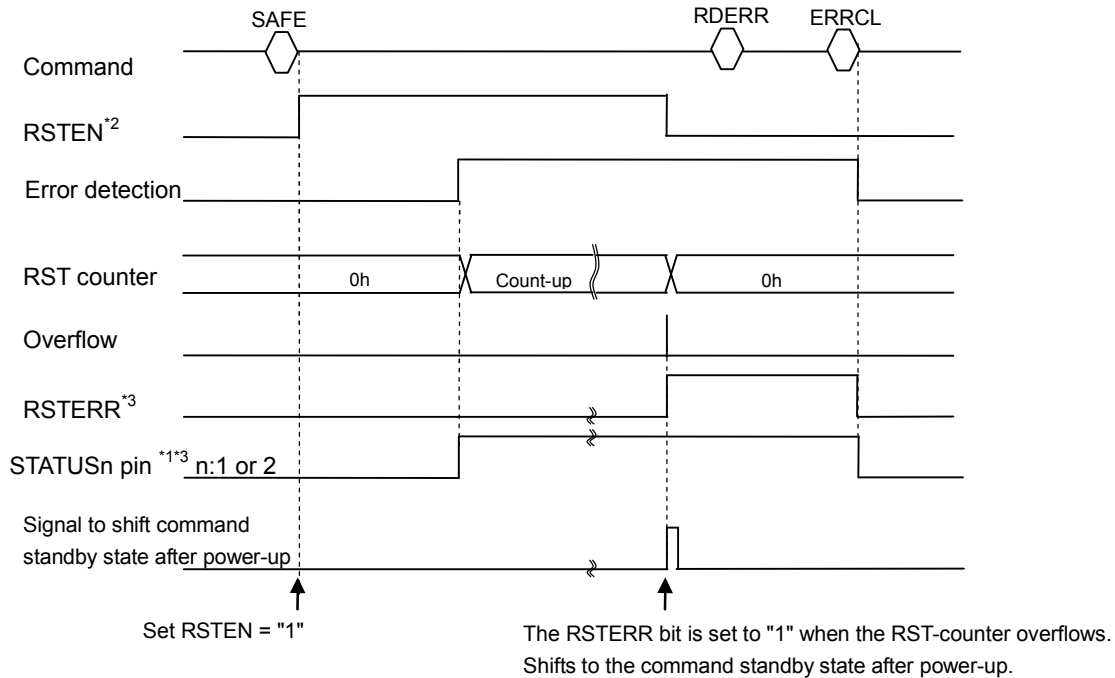

\*1 Misoperation detection and failure detection outputs are selected by OUTSTAT command.

\*2 If transferring to the command standby state after power-up is executed by the overflow of the RST counter, each bit of SAFE command is cleared. Also, error bits readable by RDERR command are cleared by ERRCL command.

\*3 Even if transferring to the command standby state after power-up is executed by the overflow of the RST counter, error bits readable by RDERR command and the state configured by OUTSTAT command remain.

< When "Transition to the state after PUP command input" is not selected by the overflow of the RST counter >

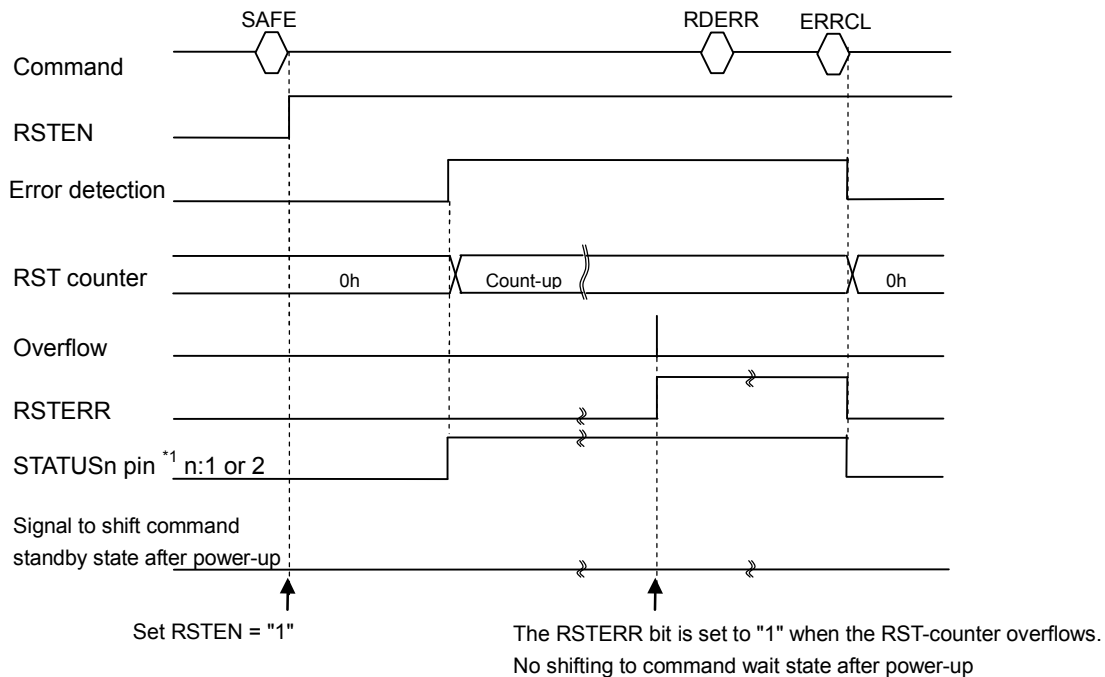

\*1 Misoperation detection and failure detection outputs are selected by OUTSTAT command.

◆ Detects the stop of clock input from a crystal resonator or ceramic resonator.

Set the "Detects the stop of clock input from a crystal resonator or ceramic resonator" with the OSCEN bit of the SAFE command.

When the clock input from the crystal resonator or the ceramic resonator is stopped, the error bit (OSCERR) is set to "1". At the same time, the clock backup function is activated and the clock is automatically switched to the RC oscillator circuit (4.096MHz).

Error bit (OSCERR) can be read with RDERR command. However, if the RDERR command (first byte) is inputted before the crystal or ceramic resonator stops and switches to RC oscillation (about 500µs), the CBUSYB pin will remain "L". Therefore, read the command after the CBUSYB pin becomes "H". Also, error bit (OSCERR) can be cleared by ERRCL command. However, if the clock input from the crystal resonator or the ceramic resonator continues to be stopped while the OSCEN bit of the SAFE command is "1", the error bit (OSCERR) is set to "1".

When the crystal resonator or the ceramic resonator stops and switches to RC oscillation, playback may become abnormal. Therefore, after confirming that the error bit (OSCERR) is "1", enter STOP command to stop playback.

If the clock input from the crystal resonator or the ceramic resonator is stopped while the OSCEN bit is "0", the error bit (OSCERR) does not change to "1", but the clock backup function is activated and the clock backup circuit is automatically switched to the RC oscillator circuit (4.096MHz).

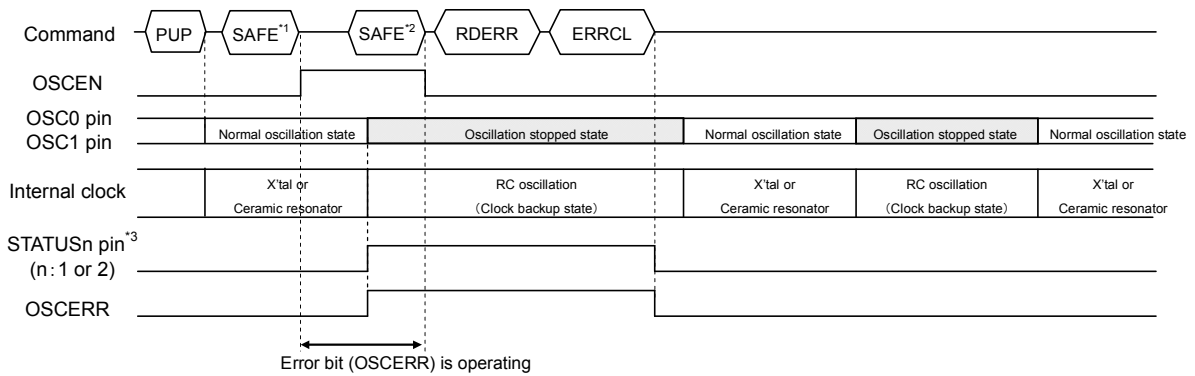

\*1 Set OSCEN = "1"

\*2 Set OSCEN = "0"

\*3 Misoperation detection and failure detection outputs are selected by OUTSTAT command.

<When the OSCEN bit of SAFE command continue to be "1">

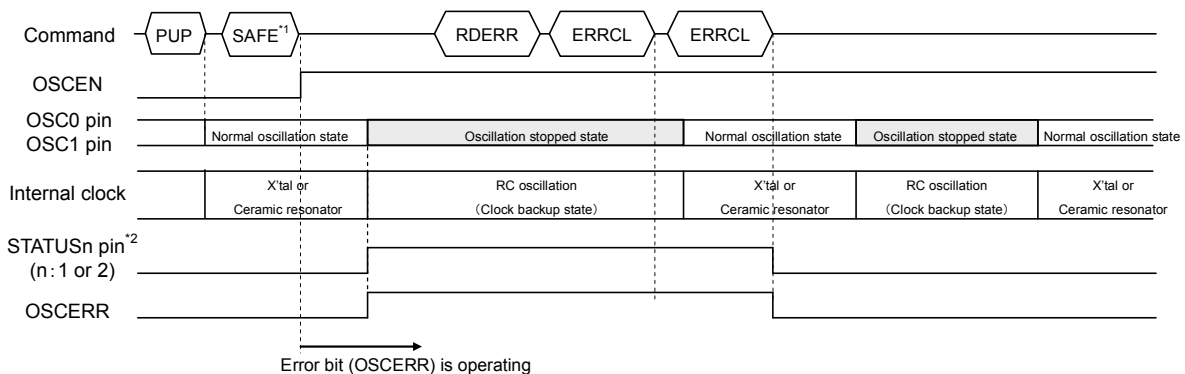

\*1 Set OSCEN = "1"

\*2 Misoperation detection and failure detection outputs are selected by OUTSTAT command.

◆ Detects disconnection/short circuit of BCLK.

Set the "Detects disconnection/short circuit of BCLK" with the BCKEN bit of the SAFE command.  
 When the BCLK is stopped, the error bit (BCKERR) is set to "1".  
 Error bit (BCKERR) can be read with RDERR command. Also, error bit (BCKERR) can be cleared by ERRCL command.

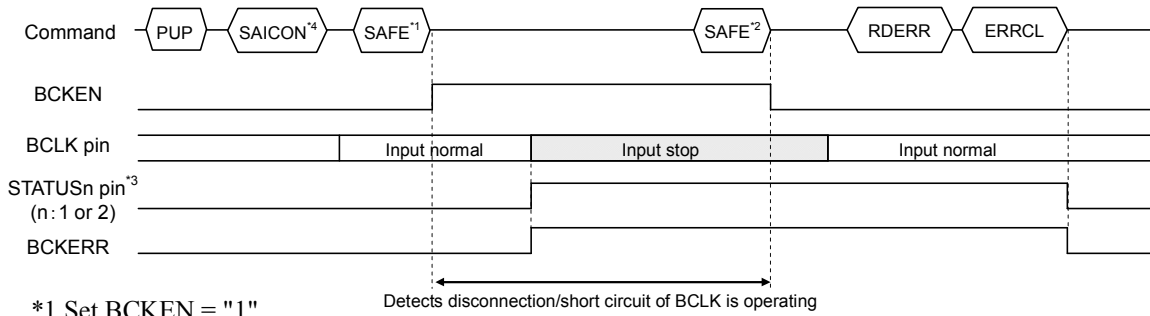

- \*1 Set BCKEN = "1"
- \*2 Set BCKEN = "0"
- \*3 Misoperation detection and failure detection outputs are selected by OUTSTAT command.
- \*4 Set OUTEN = "1" or INEN = "1"

◆ Detects disconnection/short circuit of LRCLK.

Set the "Detects disconnection/short circuit of LRCLK" with the LRCKEN bit of the SAFE command.  
 When the LRCLK is stopped, the error bit (LRCKERR) is set to "1".  
 Error bit (LRCKERR) can be read with RDERR command. Also, error bit (LRCKERR) can be cleared by ERRCL command.

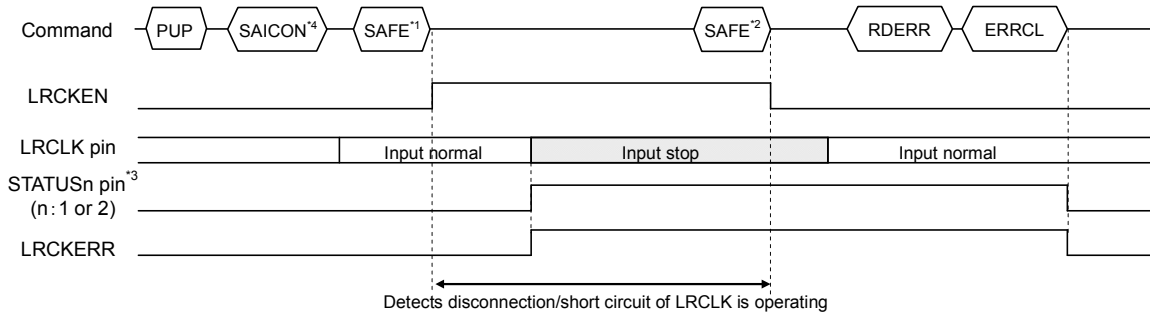

- \*1 Set LRCKEN = "1"
- \*2 Set LRCKEN = "0"
- \*3 Misoperation detection and failure detection outputs are selected by OUTSTAT command.
- \*4 Set OUTEN = "1" or INEN = "1"

< When SAFE command LRCKEN bit is "0" >

Disconnection or short circuit of LRCLK is not detected.  
 When LRCLK is faster than 5%, SAICH is initialized and the recorder stops playing.\*5 At that time, the error bit (LRCKERR) keeps "0".

< When SAFE command LRCKEN bit is "1" >

Disconnection or short circuit of LRCLK is detected.  
 When LRCLK is faster than 5%, SAICH is initialized and the recorder stops playing.\*5 At that time, the error bit (LRCKERR) changes "1".

\*5 : The unit does not recover even if a normal LRCLK is input after stopping playback. Enter MUON command → SAICH command after inputting a normal LRCLK.

◆ Detects disconnection/short circuit of SAI\_IN.

Set the "Detects disconnection/short circuit of SAI\_IN" with the SAIINEN bit of the SAFE command. When SAI\_IN does not change for more than 1.8 seconds (min.), the error bit (SAIINERR) is set to "1". Error bit (SAIINERR) can be read with RDERR command. Also, error bit (SAIINERR) can be cleared by ERRCL command. When OUTEN is set to "1" and INEN is set to "0" by the SAICON command, the SAI\_IN input is disabled. Therefore, set SAIINEN to "0".

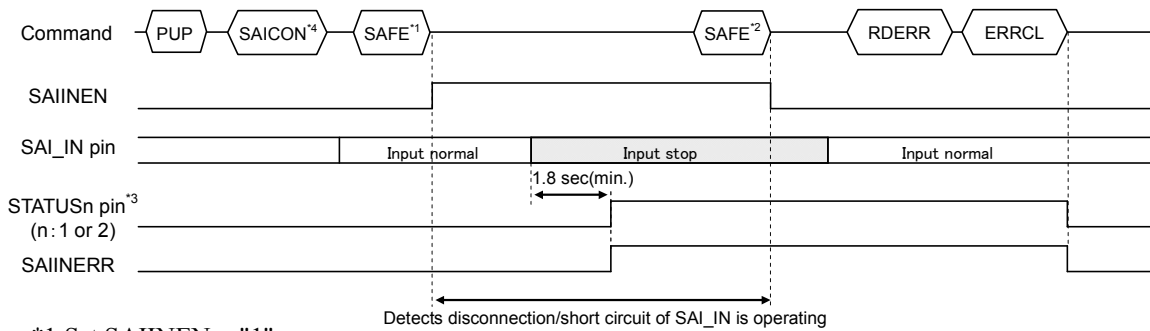

- \*1 Set SAIINEN = "1"
- \*2 Set SAIINEN = "0"
- \*3 Misoperation detection and failure detection outputs are selected by OUTSTAT command.
- \*4 Set INEN = "1"

◆ Mixing number error detection

When using the serial audio interface (SAI), the sampling frequency limits the maximum number of mixings and playable channels. If the setting exceeds the limit, it will be detected as a mixing error. Set the mixing error detection with the MIXEN bit of the SAFE command.

- ① When FS3 to FS0 = 12/24/48 kHz or 11.025/22.05/44.1 kHz is set by the SAICON command, and either LEN or REN is set to "1" by the SAICH command, specifying channel 3 and inputting the PLAY, PLAY2, START, or MUON command sets the error bit (MIXERR) to "1". Also, the input command is ignored.
- ② If FS3 to FS0 = 12/24/48 kHz or 11.025/22.05/44.1 kHz is set by the SAICON command, and if the Rch or Lch side selects channel 3 (CH3) by the SAICH command and either LEN or REN is set to "1", the error bit (MIXERR) is set to "1". Also, the entered SAICH command is ignored.

Error bit (MIXERR) can be read with RDERR command. Also, error bit (MIXERR) can be cleared by ERRCL command.

For mixing restriction when using serial audio interface (SAI), refer to "Restrictions when using Serial Audio Interface (SAI)" in the chapter on mixing function.

## ◆ Playback sound error detection

The playback sound error detection function detects error when the sound being played back by this LSI sounds different from the expected sound due to distortion, etc.

The error is detected by fetching the output of the speaker of this LSI from inside or outside of the LSI and comparing it with the playback data.

Connect the FB1 and the FB2 to the SPP and SPM to detect errors in the playback sound outside the LSI.

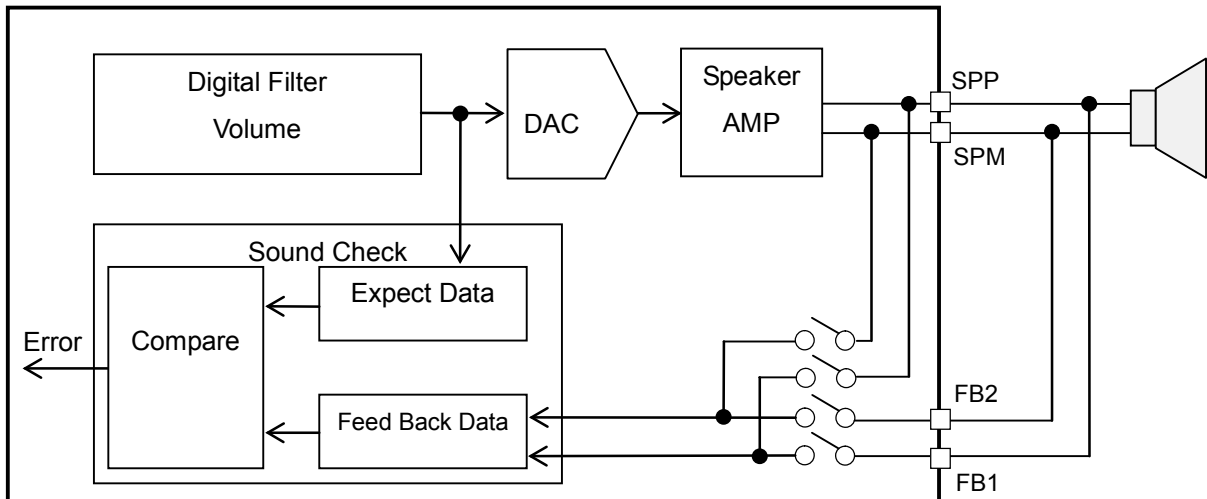

● Flash memory rewrite function

The flash memory can be rewritten in the following two ways.

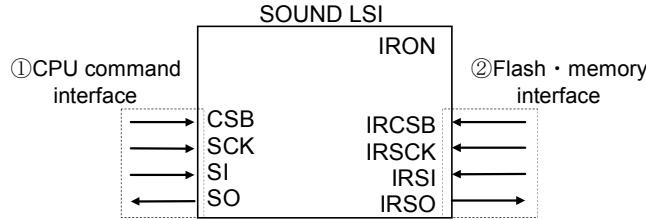

① Rewrite using the clock synchronous serial interface of the MCU command interface

By using the CSB, SCK, SI and SO pins, which are clock synchronous serial interfaces of the MCU command interface the flash memory can be rewritten. When the PUP command and FDIRECT command are entered with the IRON pin set to "L", direct access to the flash memory is enabled from the CSB, SCK, SI and SO pins.

When returning to the normal mode, insert a reset to initialize (RESETB pin is "L" level.) or shut off the power.

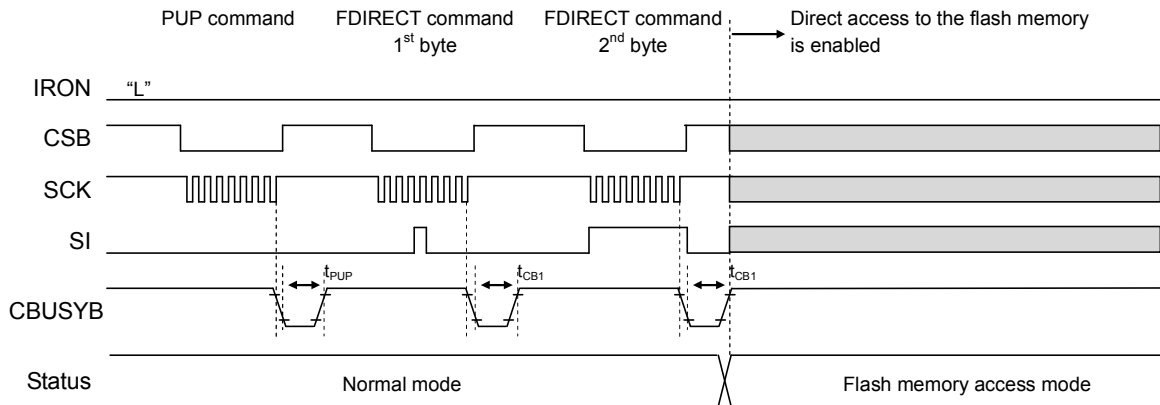

For the PUP command, refer to the "PUP command" in the "Command" section. For the FDIRECT command, refer to the "FDIRECT command" in the "Command" section.

② Rewrite using flash memory interface

The flash memory can be rewritten using the IRON, IRCSB, IRSCK, IRSI and IRSO pins that is the flash memory interface. When the PUP command and FDIRECT command are entered with the IRON pin set to "H", direct access to the flash memory is enabled from the IRCSB, IRSCK, IRSI and IRSO pins.

When returning to the normal mode, insert a reset to initialize (RESETB pin is "L" level.) or shut off the power.

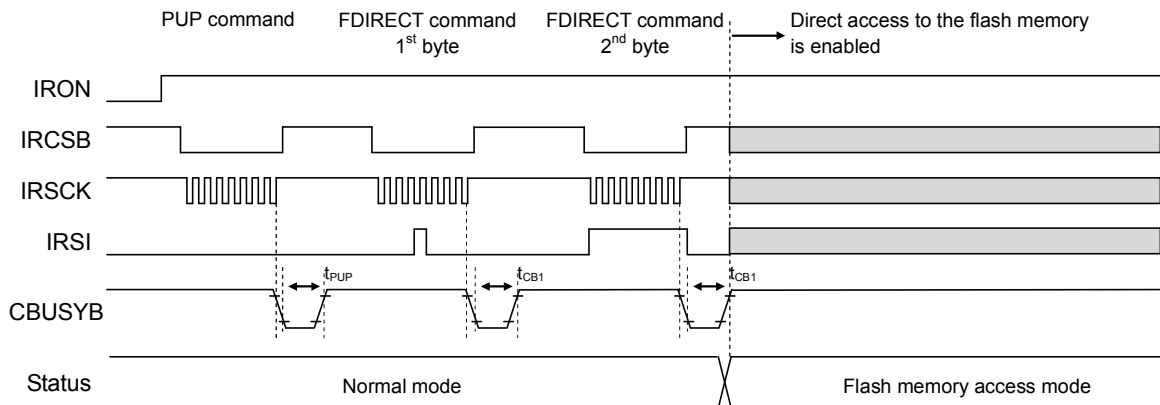

For the PUP command, refer to the "PUP command" in the "Command" section. For the FDIRECT command, refer to the "FDIRECT command" in the "Command" section.

The Chip Erase, Status Read, Program and Read of the flash memory are described on the next page.

• Chip Erase

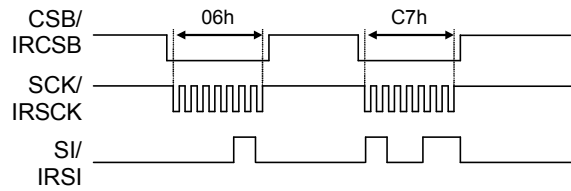

Confirm that BUSY is "0" by Status Read after Chip Erase.

• Status Read

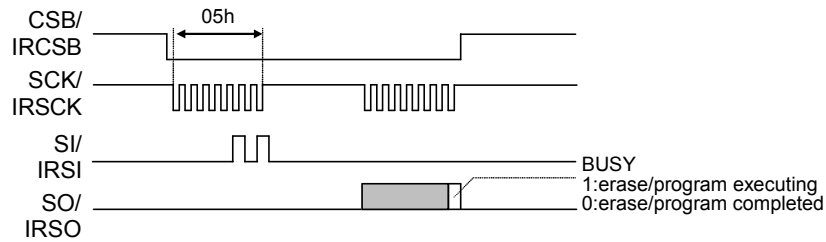

• Program

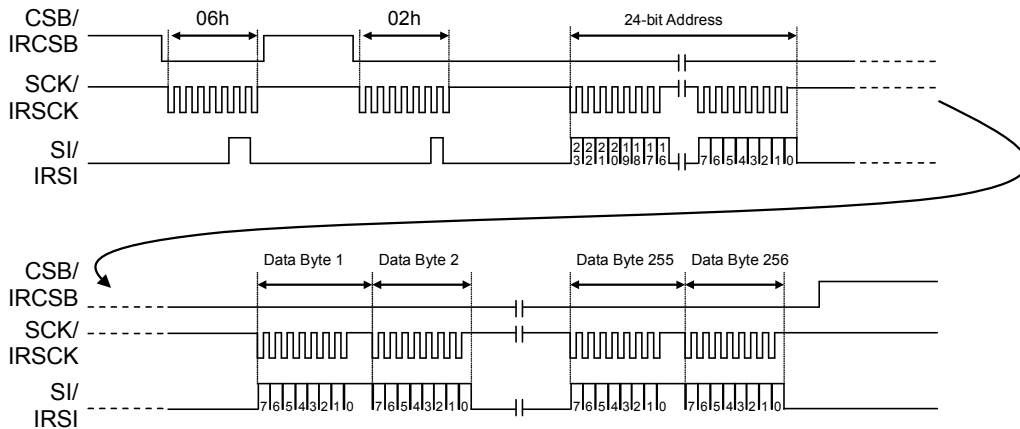

Confirm that BUSY is "0" by Status Read after Program.

• Read

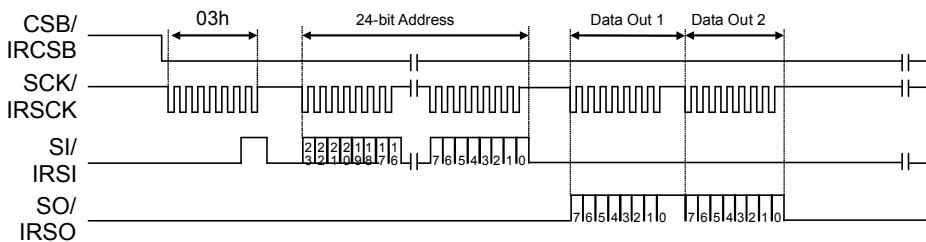



■ Timing chart

● Common

◆ Power-on timing

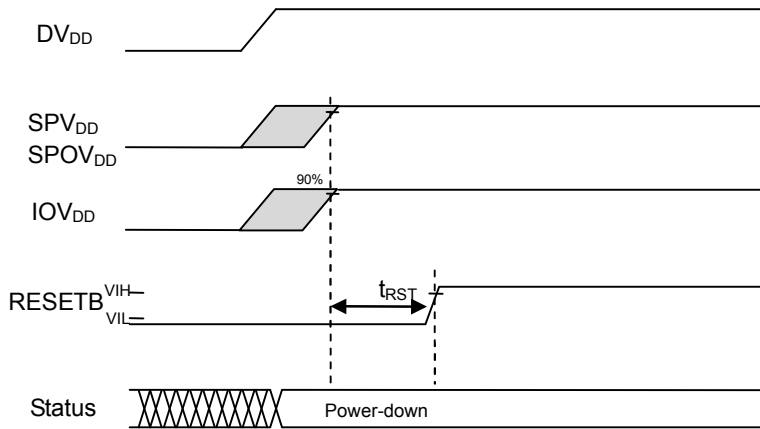

After the power is turned on, the device enters the power-down state.  
 Start up in the order of DV<sub>DD</sub>, SPV<sub>DD</sub> and IOV<sub>DD</sub> or DV<sub>DD</sub>, IOV<sub>DD</sub> and SPV<sub>DD</sub>.  
 It is possible that the DV<sub>DD</sub> and SPV<sub>DD</sub> start up at the same time and then the IOV<sub>DD</sub> starts up, or the DV<sub>DD</sub> and IOV<sub>DD</sub> starts up at the same time and then the SPV<sub>DD</sub> starts up.  
 The DV<sub>DD</sub>, SPV<sub>DD</sub> and IOV<sub>DD</sub> can also start up at the same time.  
 t<sub>RST</sub> is specified based on the last power-on pin.

Be sure to input "L" to the RESETB pin before inputting the first command after power-on.  
 Be sure to enter "L" at the RESETB pin when the DV<sub>DD</sub> is below the (recommended) operating voltage range.

◆ Power-off timing

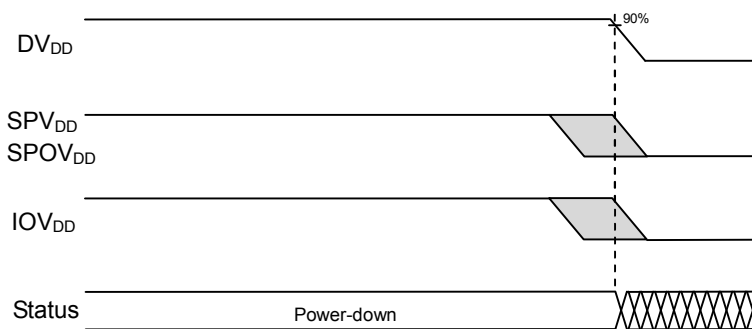

Shut down in the order of IOV<sub>DD</sub>, SPV<sub>DD</sub>, and DV<sub>DD</sub> or SPV<sub>DD</sub>, IOV<sub>DD</sub>, and DV<sub>DD</sub>.  
 It is possible that the IOV<sub>DD</sub> shuts down and then the SPV<sub>DD</sub> and DV<sub>DD</sub> shuts down at the same time,  
 or the SPV<sub>DD</sub> shuts down and then the IOV<sub>DD</sub> and DV<sub>DD</sub> shut down at the same time.  
 The DV<sub>DD</sub>, SPV<sub>DD</sub> and IOV<sub>DD</sub> can also shut down at the same time.

Shut down each power supply after changing to the power down status with PDWN commands.

◆ Reset input timing

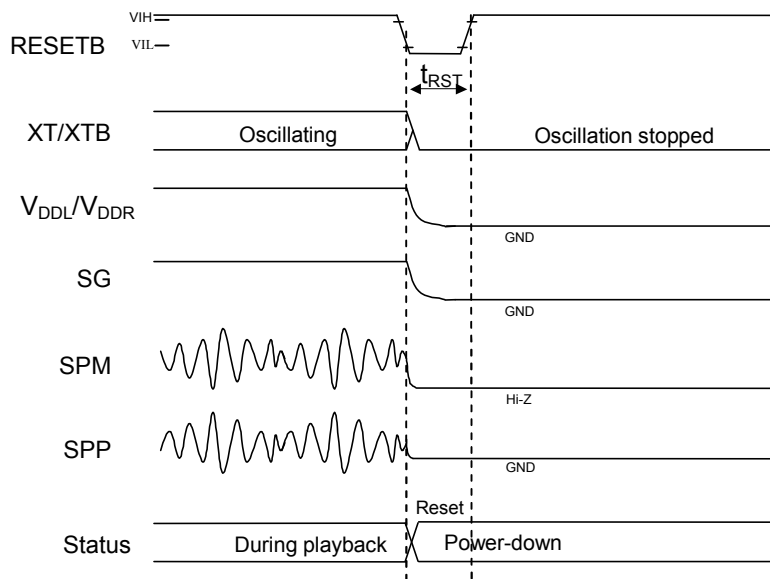

The same timing is applied when a reset is input during command standby.

◆ SAI interface timing (slave)

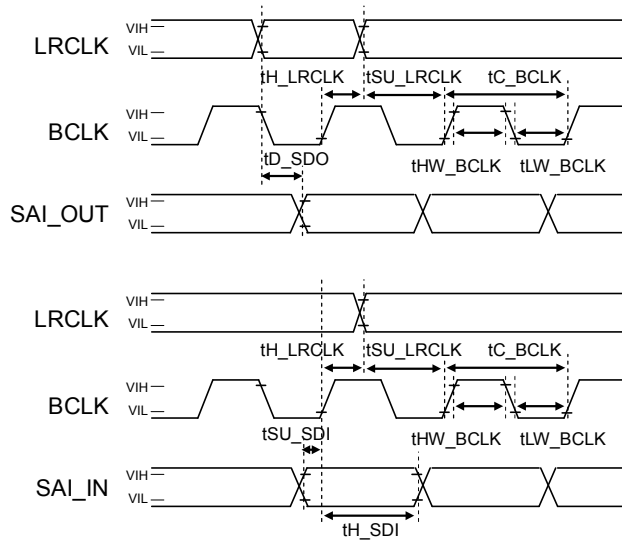

◆ Flash memory interface timing

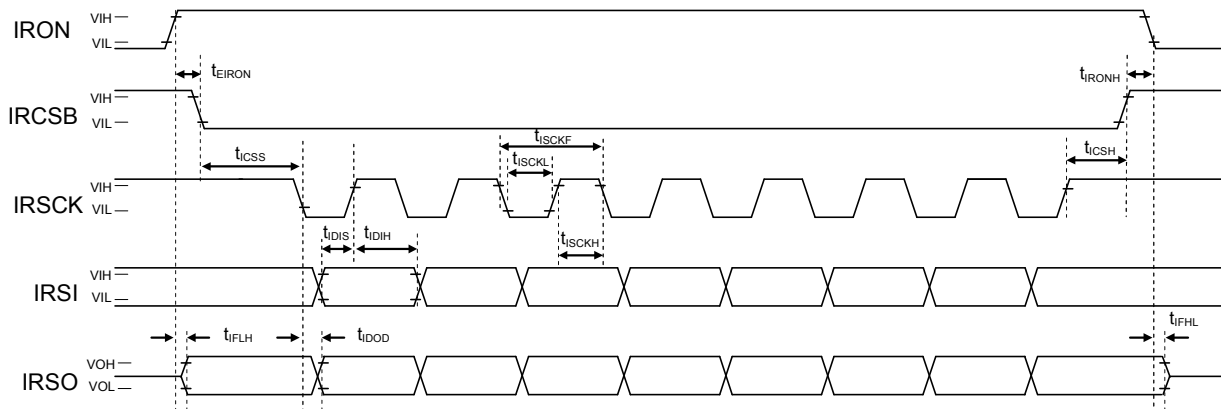



◆ Power-up timing

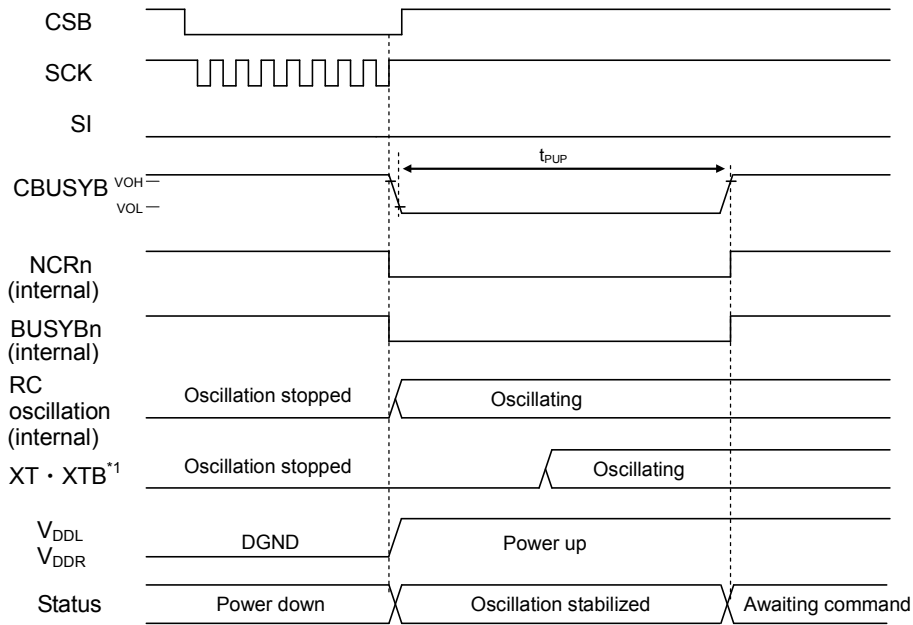

\*1 When using a crystal or ceramic resonator

◆ Power-down timing

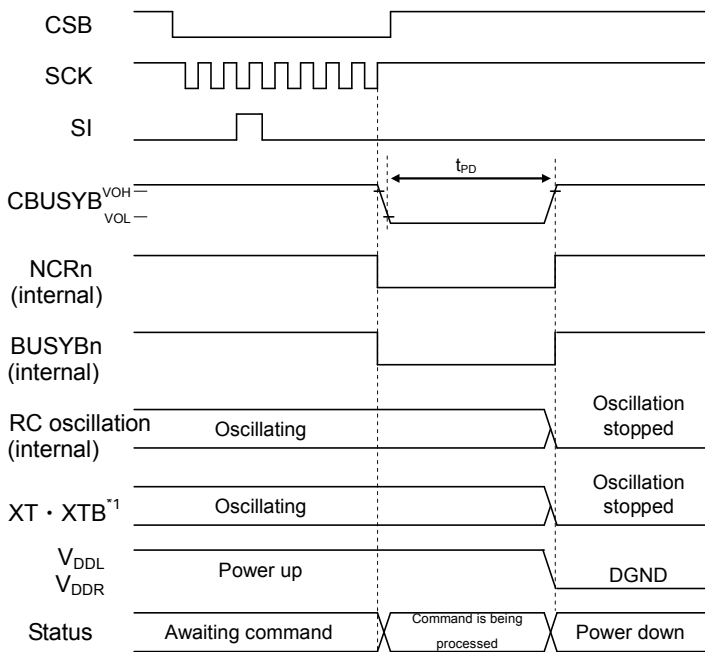

\*1 When using a crystal or ceramic resonator

◆ Speaker amplifier power-up timing (DAMP bit = "0", AEN1 bit = "0", AEN0 bit = "0" → "1")

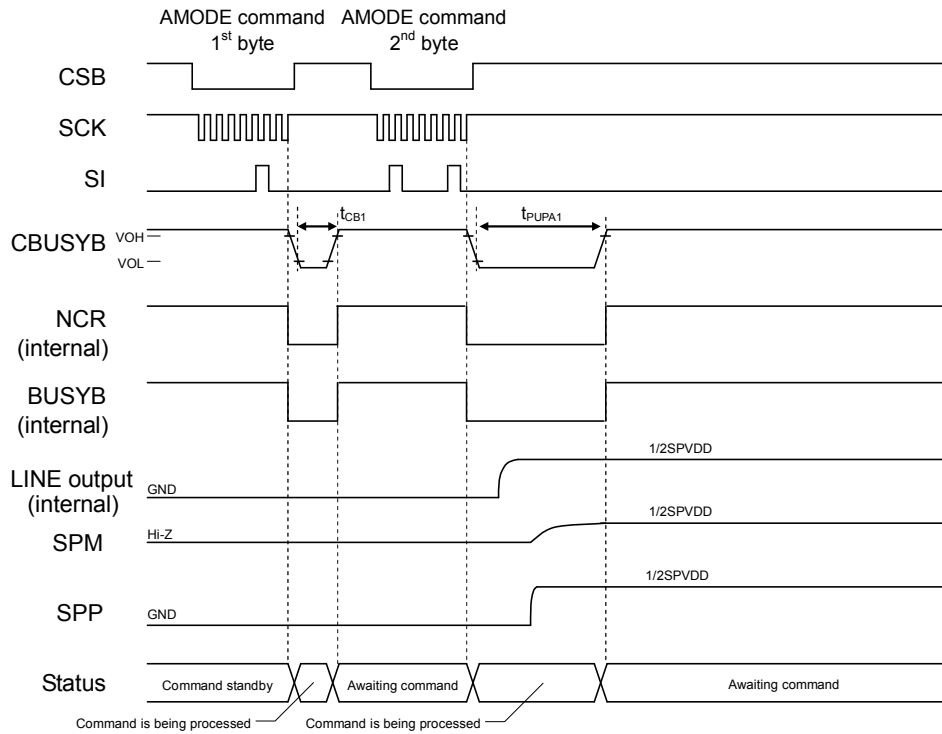

◆ Line amplifier power-up timing (DAMP bit = "0", POP bit = "1", AEN1 bit = "0" → "1", AEN0 bit = "0")

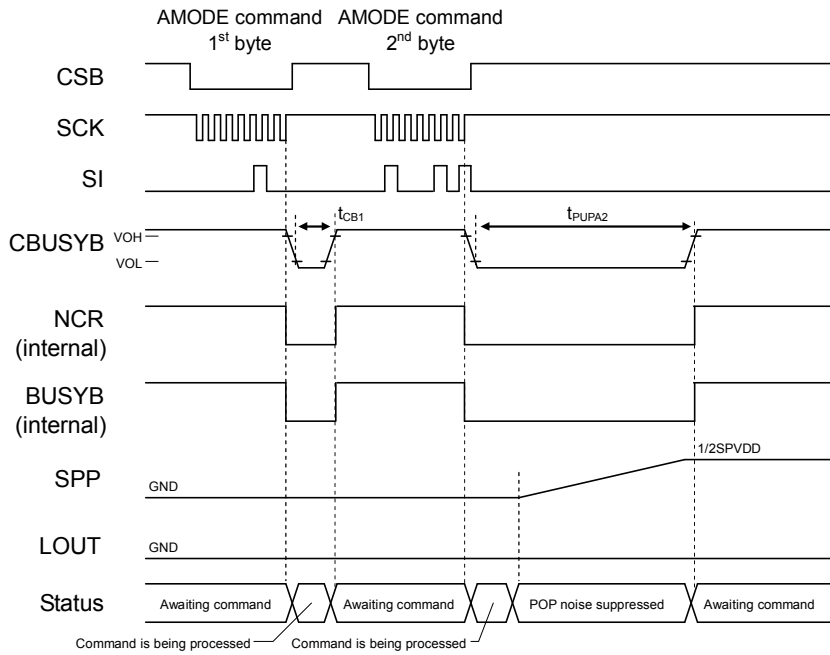

◆ Line amplifier power-up timing (DAMP bit = "0", POP bit = "0", AEN1 bit = "0" → "1", AEN0 bit = "0")

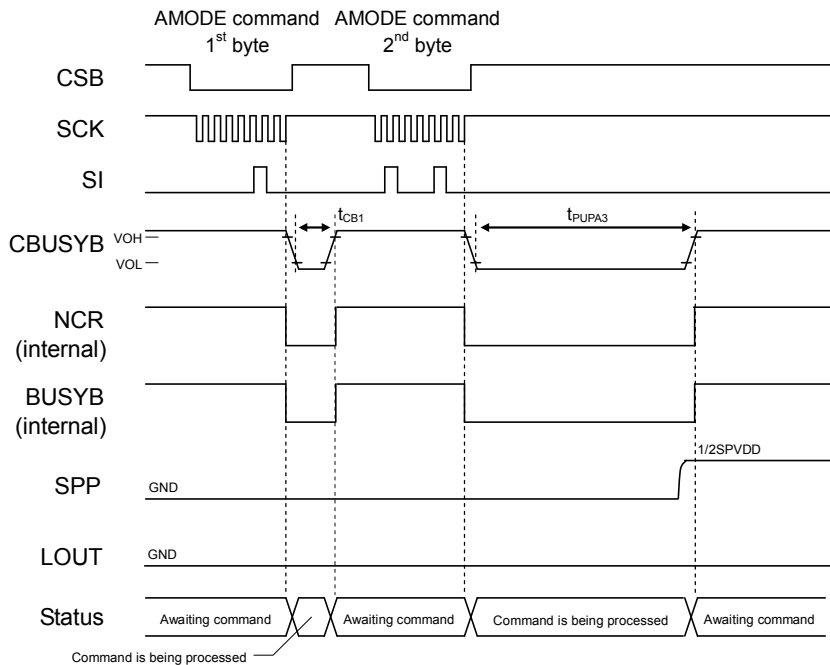

◆ Line amplifier power-up timing (DAMP bit = "0", POP bit = "1", AEN1 bit = "0" → "1", AEN0 bit = "0" → "1")

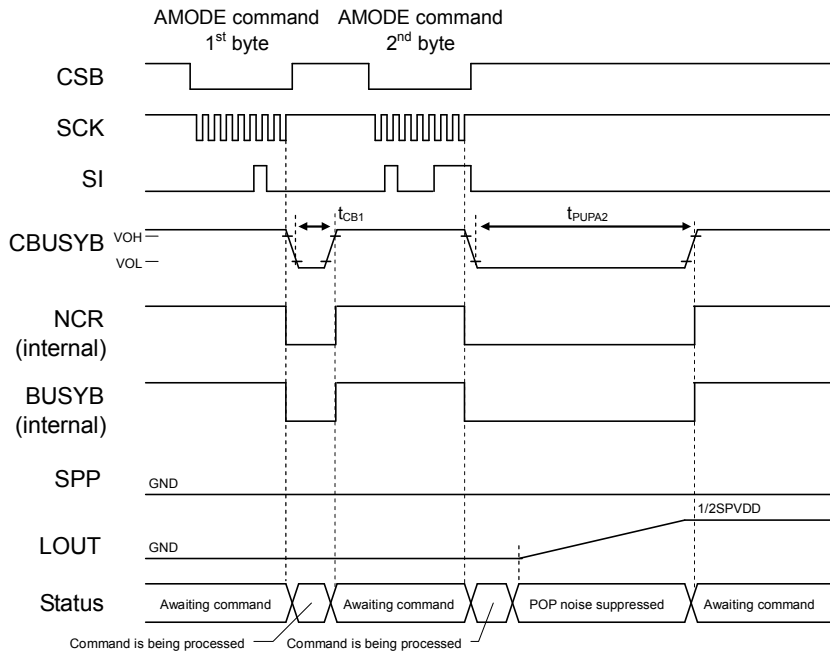

◆ Line amplifier power-up timing (DAMP bit = "0", POP bit = "0", AEN1 bit = "0" → "1", AEN0 bit = "0" → "1")

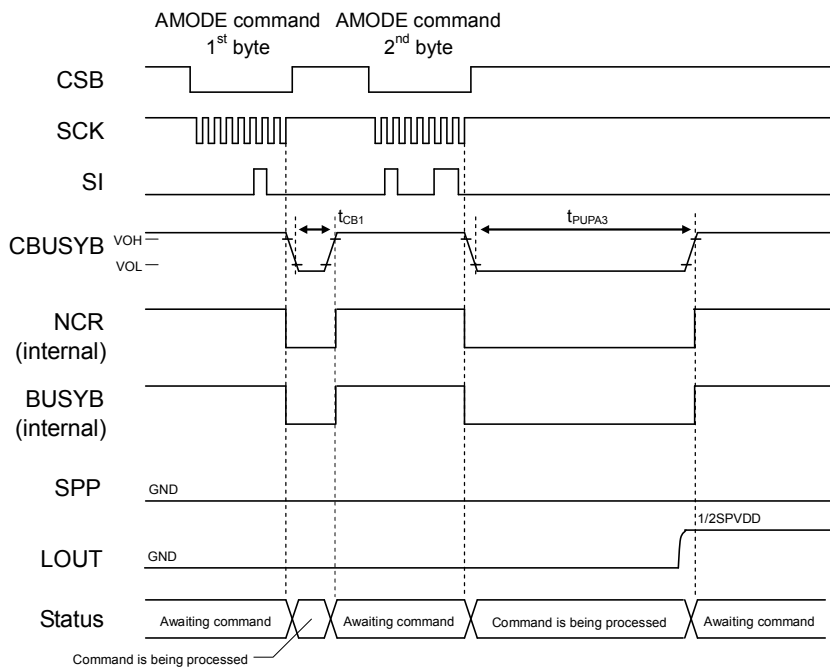



◆ Speaker amplifier power-down timing (DAMP bit = "0", AEN1 bit = "0", AEN0 bit = "1" → "0")

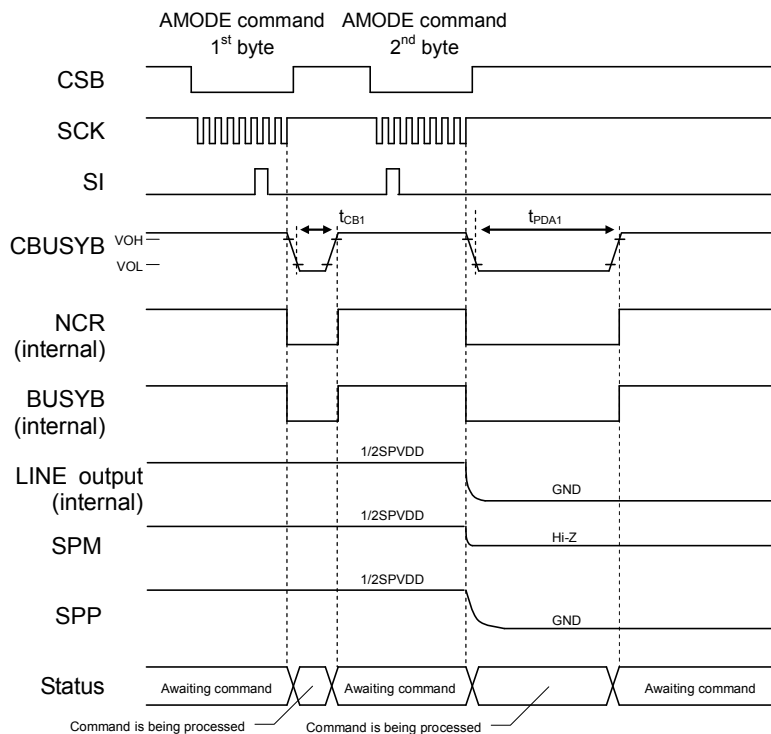

◆ Line amplifier power-down timing (DAMP bit = "0", POP bit = "1", AEN1 bit = "1" → "0", AEN0 bit = "0")

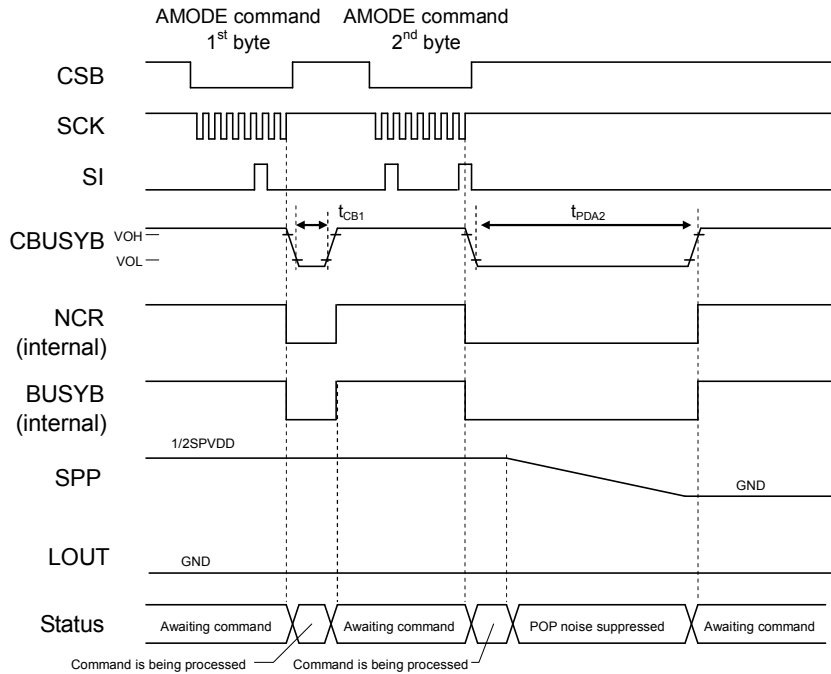

◆ Line amplifier power-down timing (DAMP bit = "0", POP bit = "0", AEN1 bit = "1" → "0", AEN0 bit = "0")

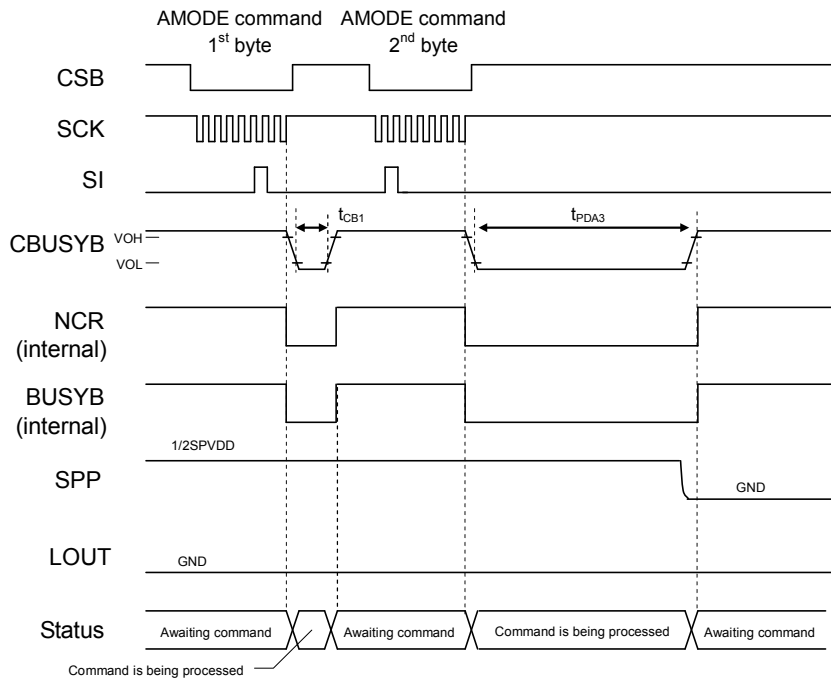

◆ Line amplifier power-down timing (DAMP bit = "0", POP bit = "1", AEN1 bit = "1" → "0", AEN0 bit = "1" → "0")

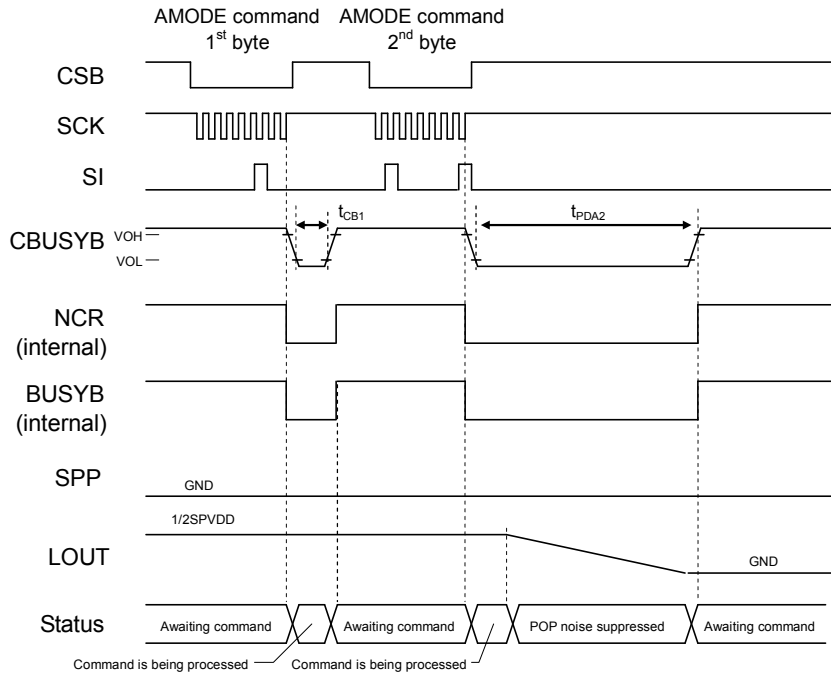

◆ Line amplifier power-down timing (DAMP bit = "0", POP bit = "0", AEN1 bit = "1" → "0", AEN0 bit = "1" → "0")

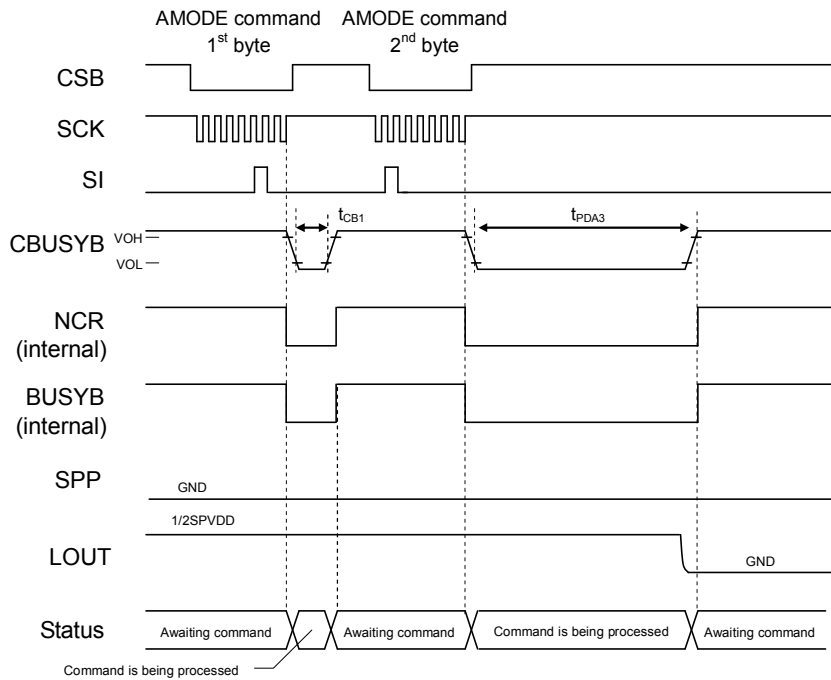

◆ FDIRECT command timing

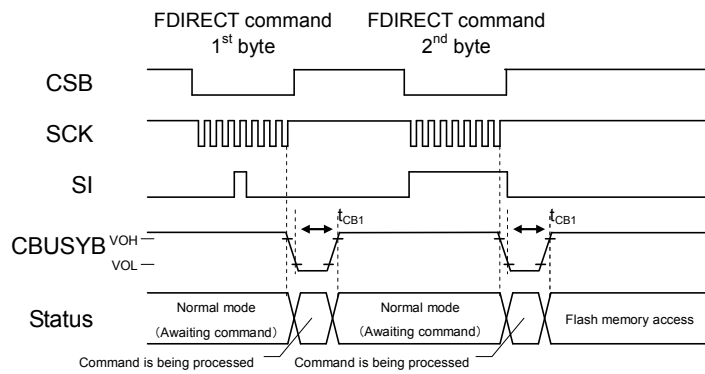

◆ WDTCL command timing

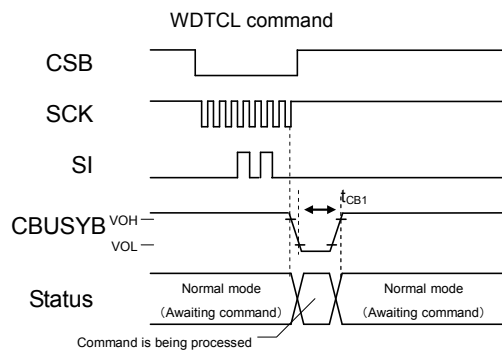

◆ Change volume timing by AVOL command

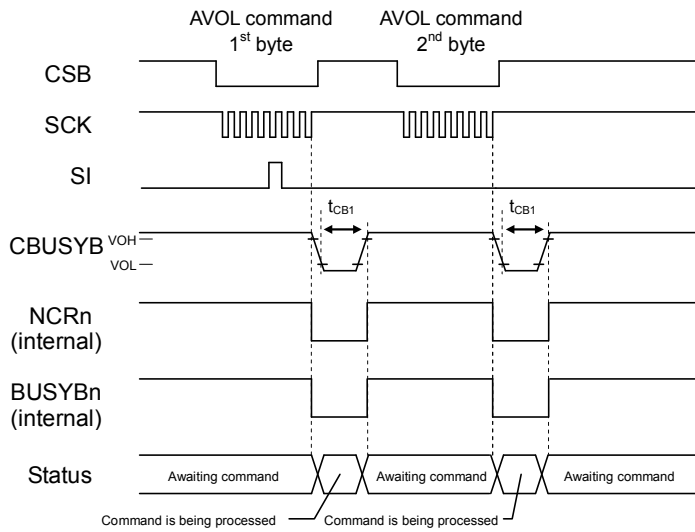

Speaker amplifier volume setting by AVOL commands is valid only when Class AB speaker amplifier is used. When a Class D speaker amplifier is used, the setting value is ignored and +0.0dB is selected.

◆ FADE command timing

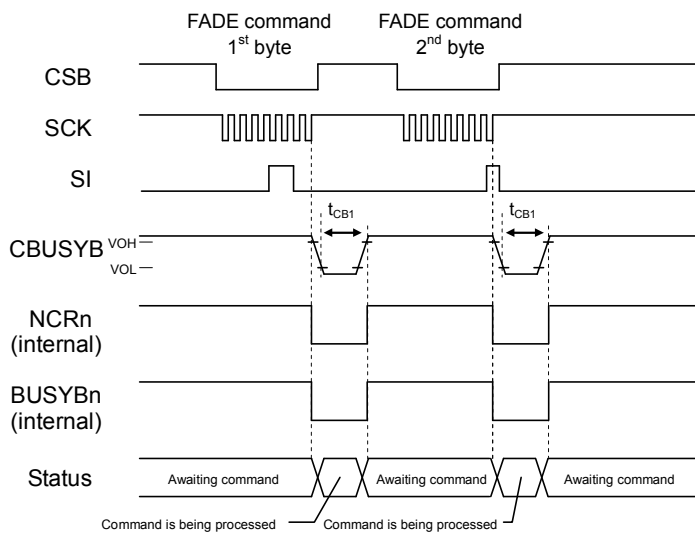

◆ Setting playback phrases using FADR command

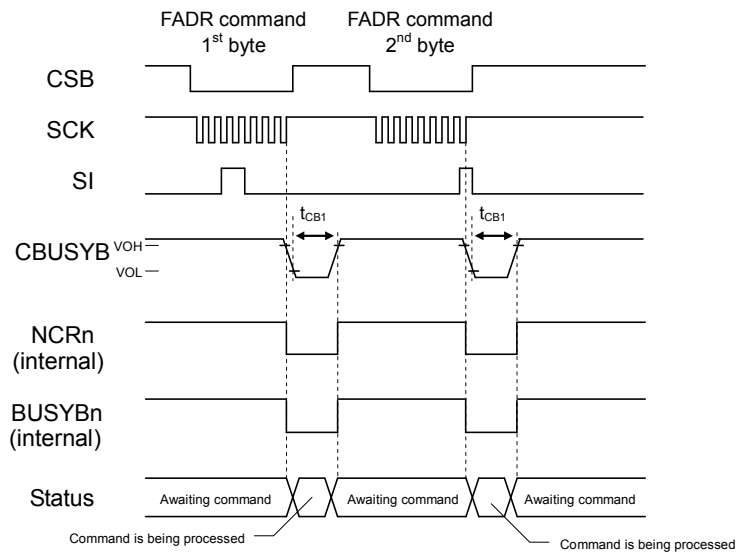

◆ Playback start timing by PLAY command

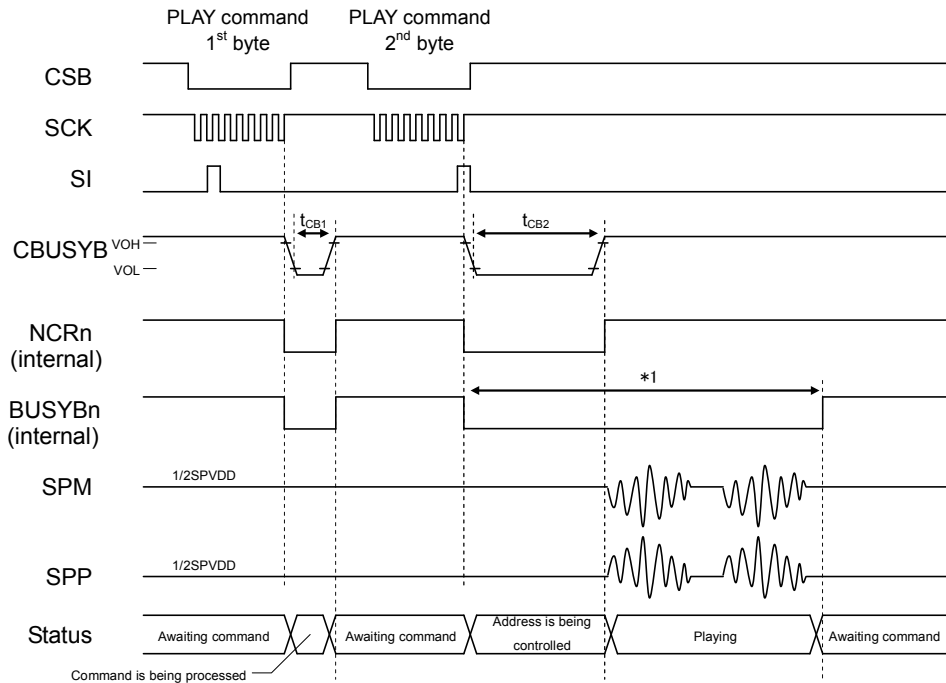

When the first byte of the PLAY command is input, the device waits for the input of the second byte after the command processing time ( $t_{CB1}$ ). When the second byte is entered, the address data of the phrase to be played after the command processing time ( $t_{CB2}$ ) is read from the flash memory.

When the phrase address data is read, the specified phrase starts playback, and when playback is completed, the BUSYB signal of the playback channel becomes "H" level.

The NCR signal goes to the "L" level during playback preparation, and goes to the "H" level when playback preparation is completed and playback starts. When the NCR signal of the playback channel becomes "H" level, the PLAY command of the next phrase to be played can be accepted.

\*1 The length of the "L" interval in the BUSYBn is ( $t_{CB2}$ + sound production time).

◆ Continuous playback timing by PLAY command

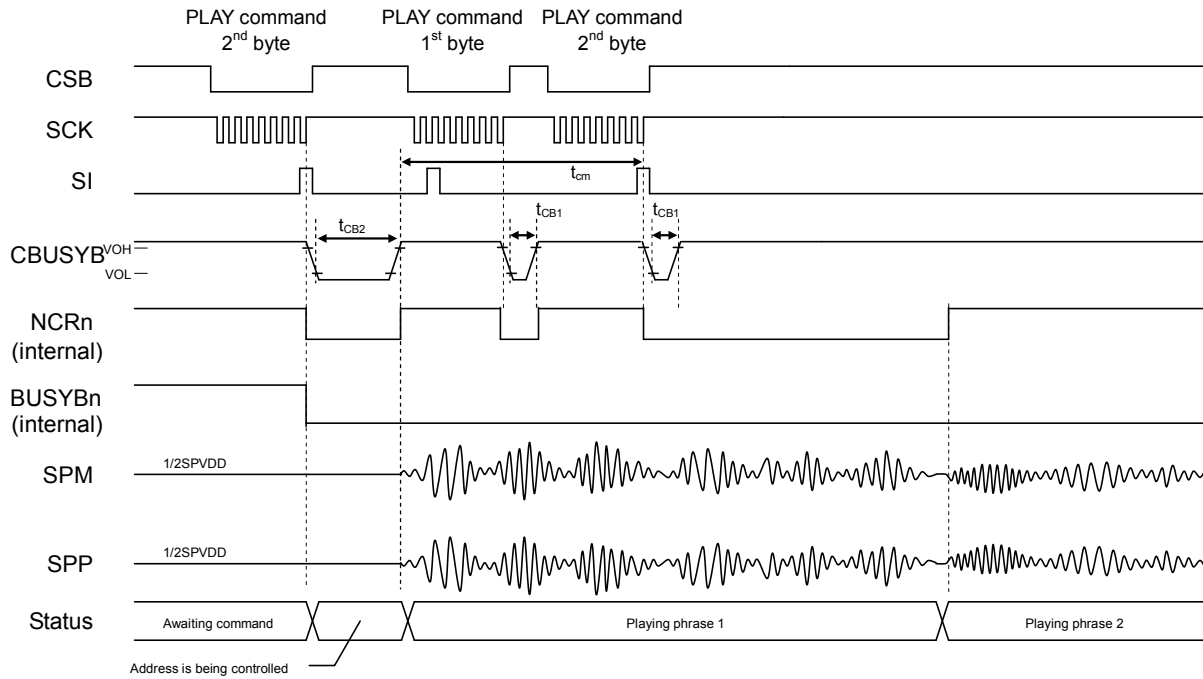

When making continuous playbacks, input the PLAY command for the next phrases within the specified time period ( $t_{cm}$ ) after the NCR of the corresponding channel changes to "H" level, so that the LSI playbacks the next phrases without silence sounds after the current phrase playback ends.

When the playback is not continuous, input the PLAY command for the next phrases after confirming the playback is completed by RDSTAT command, etc.



◆ Playback start timing by START command

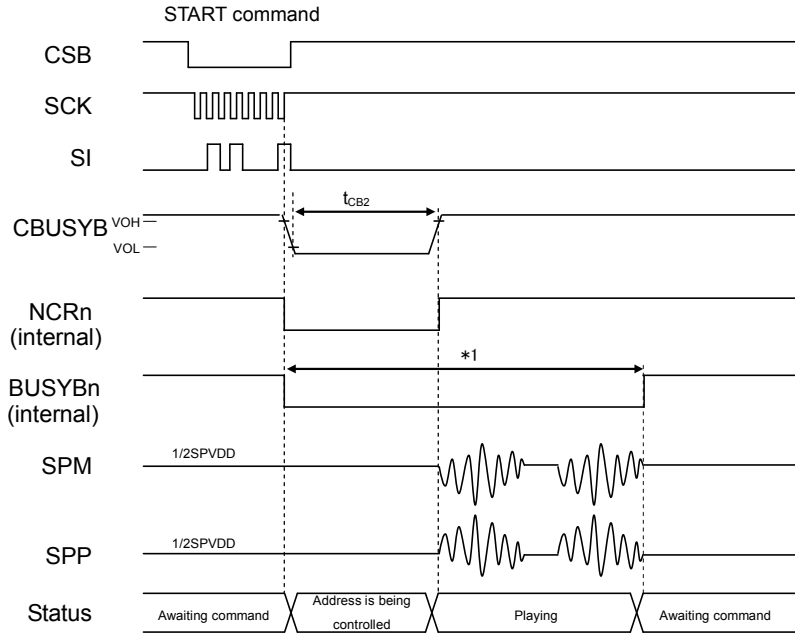

When the START command is input, the address data of the phrase to be played after the command processing time ( $t_{CB2}$ ) is read from the flash memory. When the phrase address data is read, the specified phrase starts playback, and when playback is completed, the BUSYB signal of the playback channel becomes "H" level.

The NCR signal goes to the "L" level during playback preparation, and goes to the "H" level when playback preparation is completed and playback starts. When the NCR signal of the playback channel becomes "H" level, the START command of the next phrase to be played can be accepted.

\*1 The length of the "L" interval in the BUSYBn is ( $t_{CB2}$ + sound production time).

◆ Continuous playback timing by START command

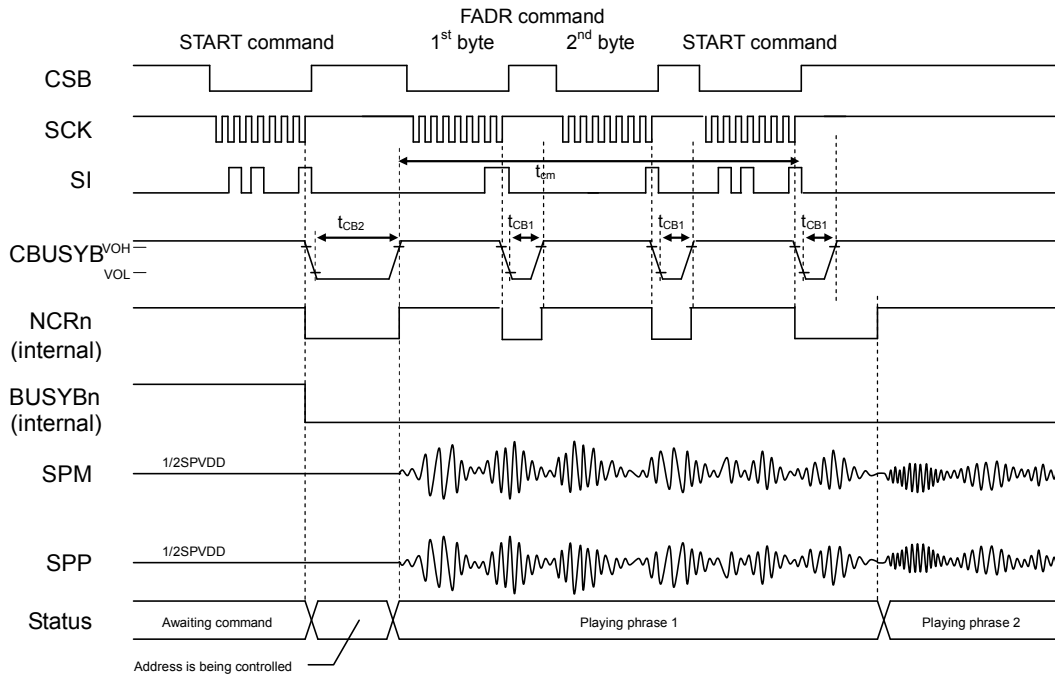

When making continuous playbacks, input the START command for the next phrases within the specified time period ( $t_{cm}$ ) after the NCR of the corresponding channel changes to "H" level, so that the LSI plays back the next phrases without silence sounds after the current phrase playback ends.

When the playback is not continuous, input the START command for the next phrases after confirming the playback is completed by RDSTAT command, etc.

◆ STOP command (when the FAD bit is "L")

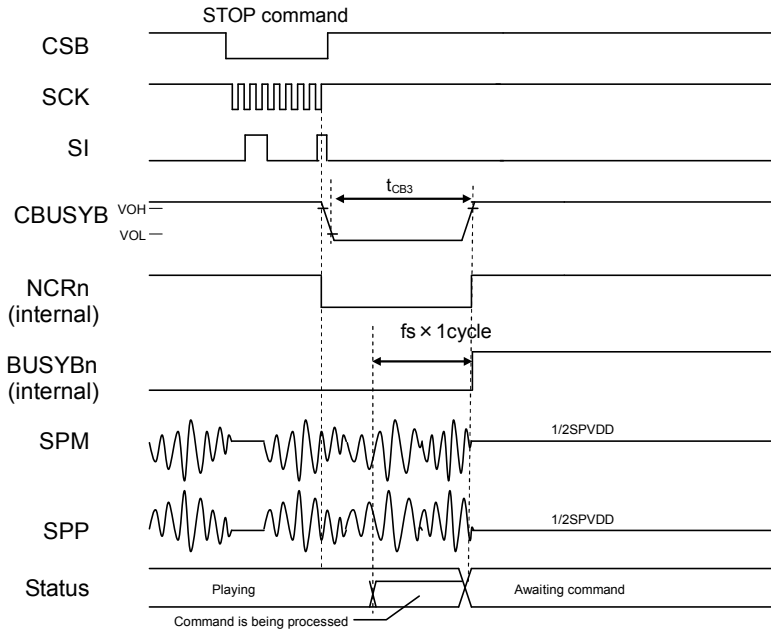

◆ STOP command (when the FAD bit is "H")

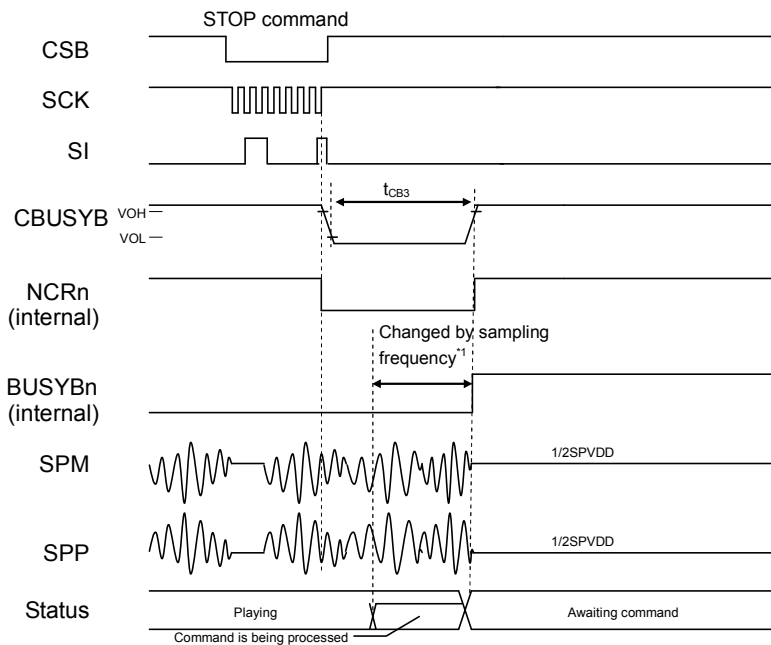

\*1 The duration of the BUSYBn varies depending on the sampling frequency groups.

- At 10.7/21.3kHz : Approx. 3ms
- At 6.4/12.8/25.6kHz : Approx. 5ms
- At 8.0/16.0/32.0kHz : Approx. 4ms
- At 11.025/22.05/44.1kHz : Approx. 2.9ms
- At 12.0/24.0/48.0kHz : Approx. 2.7ms

◆ Playback start timing by MUON command

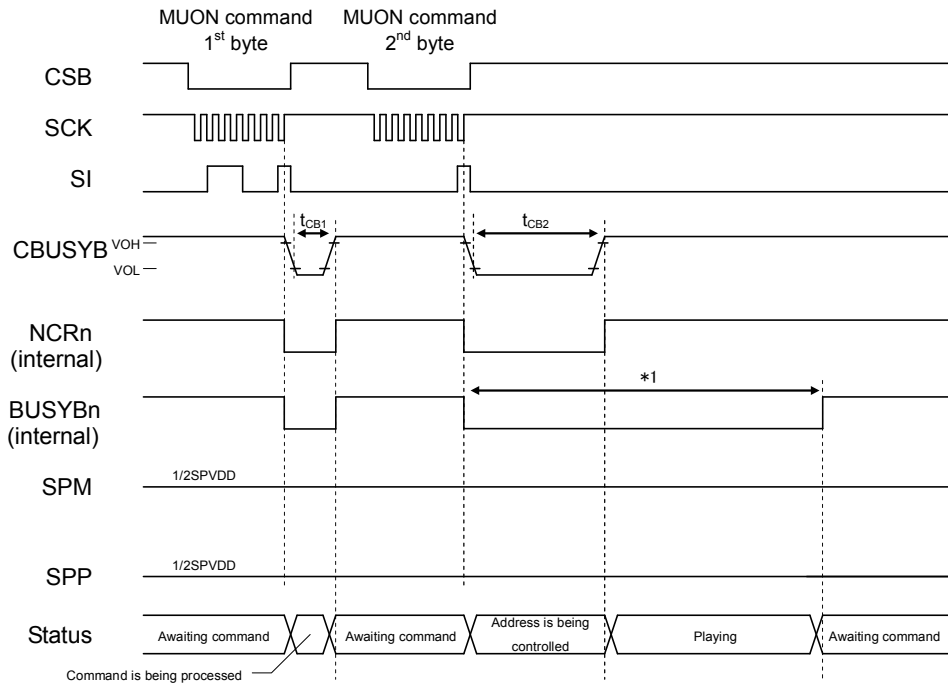

When the first byte of the MUON command is input, the device waits for the input of the second byte after the command processing time ( $t_{CB1}$ ). When the second byte is entered, the silence time is calculated after the command processing time ( $t_{CB2}$ ). When the calculation of the silence duration is completed, the calculated silence is played back, and when the playback is completed, the BUSYB signals of the playback channels become "H" level.

The NCR signal becomes "L" level during playback preparation, and becomes "H" level when playback preparation is completed and playback starts. When the NCR signal of the playback channel becomes "H" level, the PLAY command of the next phrase to be played can be accepted.

\*1 The length of the "L" interval of the BUSYBn is ( $t_{CB2}$ + silence playback time).

◆ Continuous playback timing by MUON command

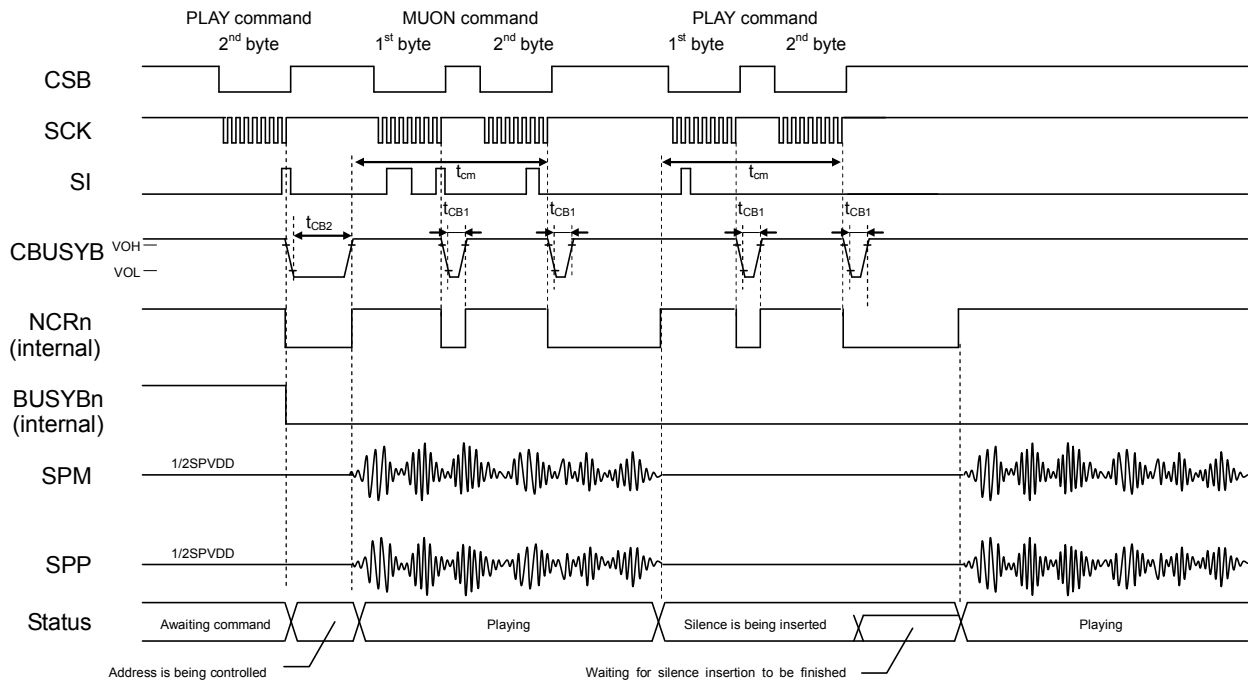

After the PLAY command is input, the CBUSYB signal and NCR signal change to "H" level when the address management of phrase 1 is completed and start playing back. Input the MUON command after the CBUSYB signal changed to "H" level. After the MUON command is received, the LSI is in a state waiting for the end of playback of phrase 1 and the NCR signal remains "L" level until the end of playback.

When the playback of phrase 1 ends, playback of the silence sound starts and the NCR signal changes to "H" level. After the NCR signal of the corresponding channel changes to "H" level, send the PLAY command again to playback the phrase 1. The NCR signal changes to "L" level again after the PLAY command is received and the LSI is in a state waiting for the end of the playback of silence sound.

After ending the playback of silence sound and starting the playback of phrase 1, the NCR signal changes to "H" level and LSI is in state that accepts the next PLAY or MUON command. The BUSYB signal remains "L" level until the sequence of playback is completed.

When making continuous playbacks, input the MUON/PLAY/START command for the next phrases within 10ms ( $t_{cm}$ ) after the NCR of the corresponding channel changes to "H" level. When the playback is not continuous, input the MUON/PLAY/START command for the next phrases after confirming the playback is completed by RDSTAT command, etc.

◆ Repeat playback setting/release timing by SLOOP/CLOOP command

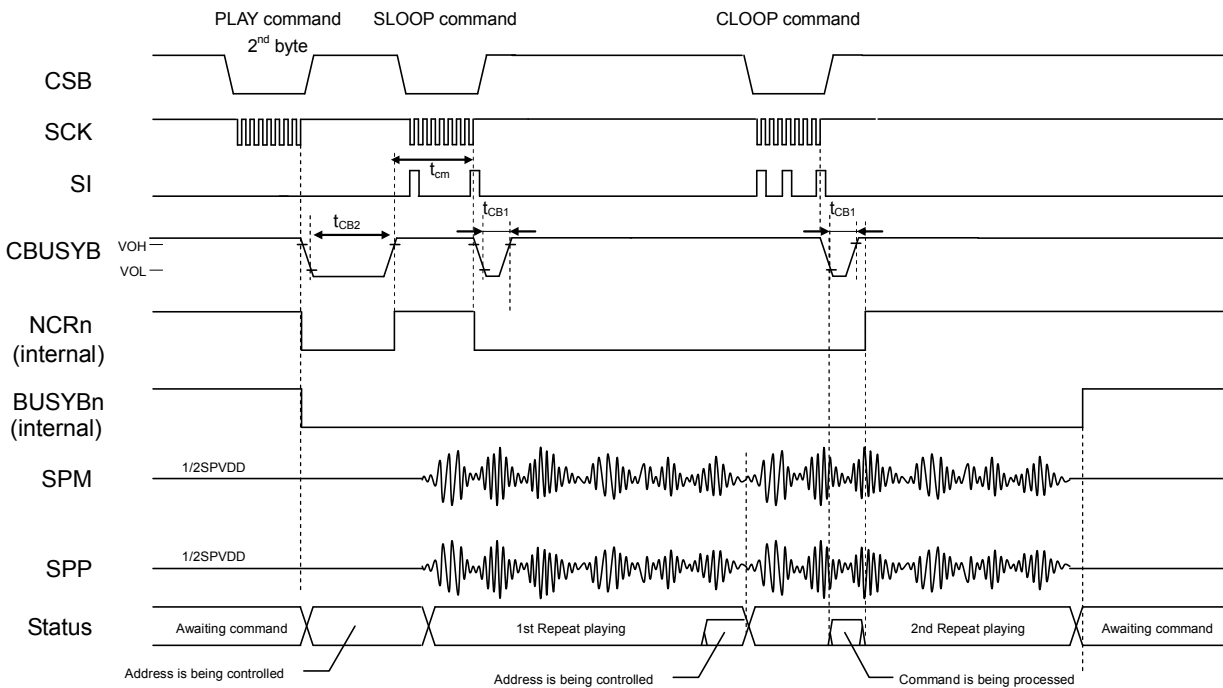

The SLOOP command is valid only during playback. After the PLAY command is input, input the SLOOP command within the specified period ( $t_{cm}$ ) after the NCR of the corresponding channel becomes "H" level. This enables the SLOOP command and repeats playback. While the repeat playback mode is set, the NCR signal is "L" level.

◆ Change volume timing by CVOL command

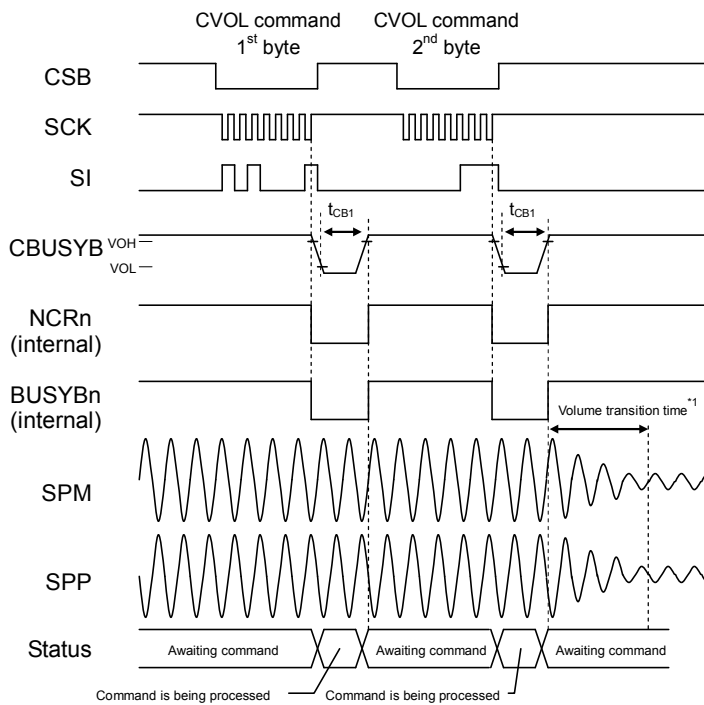

\*1 Refer to the "FADE command" for more information on volume-transition time.

◆ RDSTAT command timing

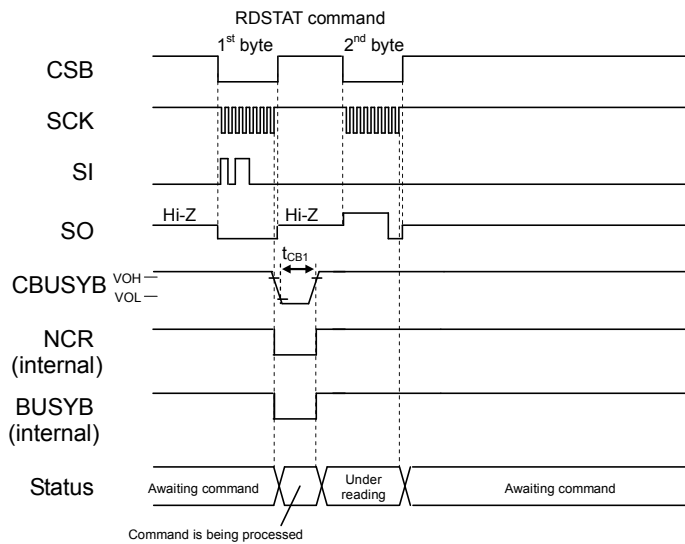

◆ RDVER command timing

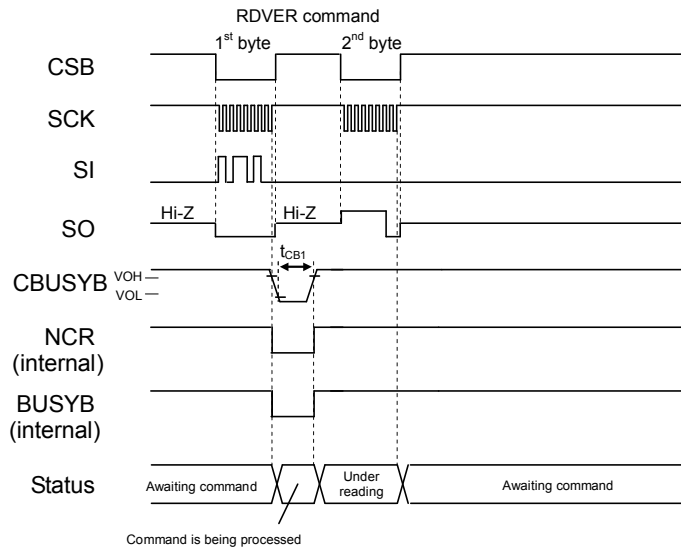

◆ RDERR command timing

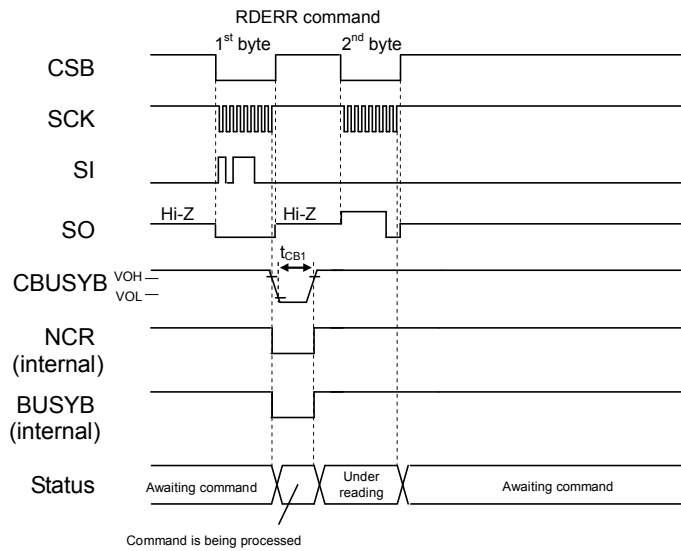



◆ OUTSTAT command timing

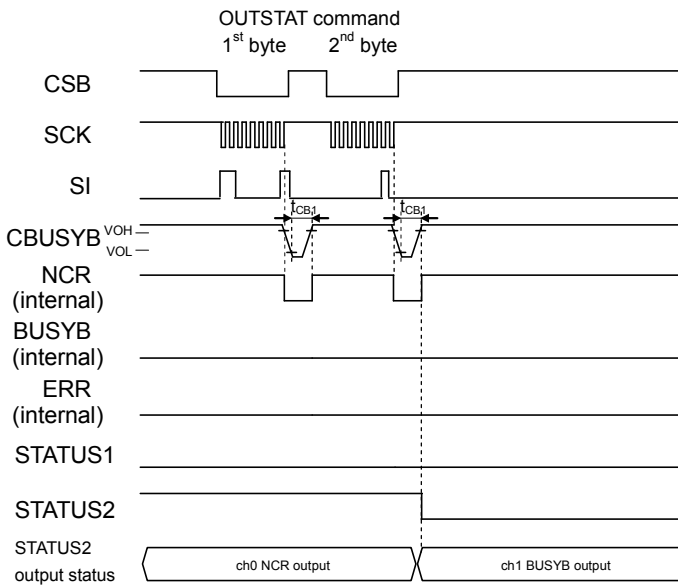

◆ SAFE command timing

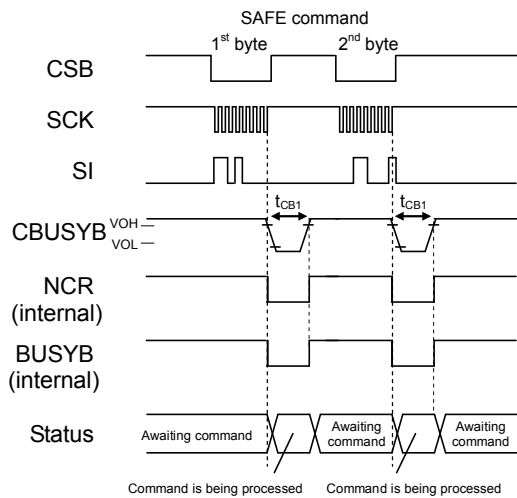

◆ ERRCL command timing

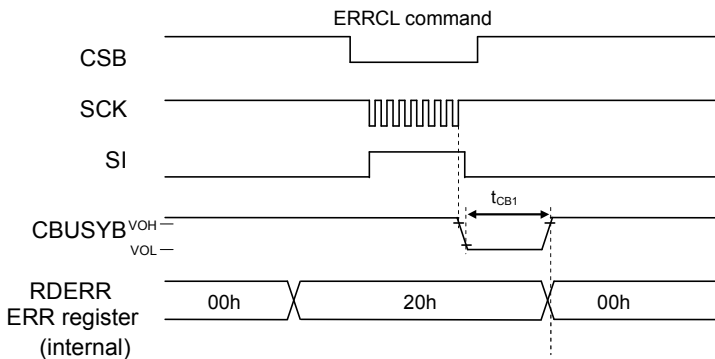

◆ Setting timing of playback phrases by FADR2 command

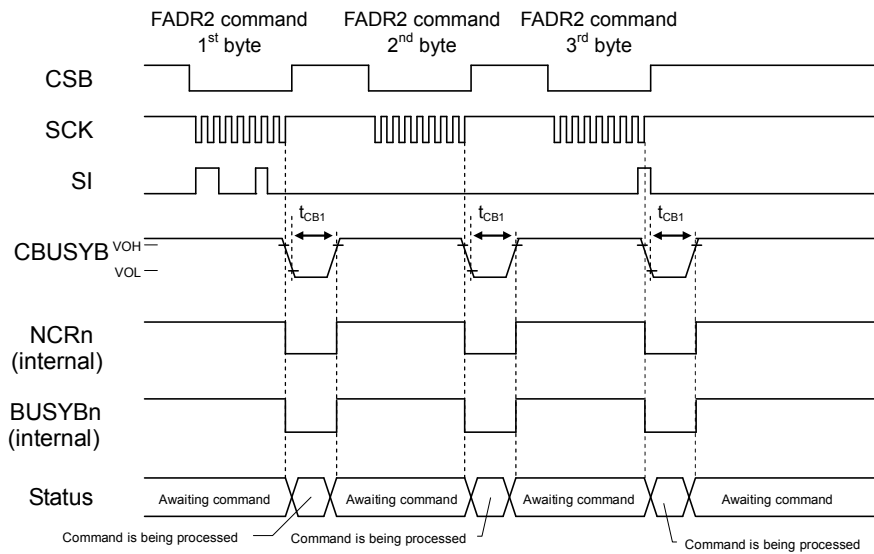

◆ Playback start timing by PLAY2 command

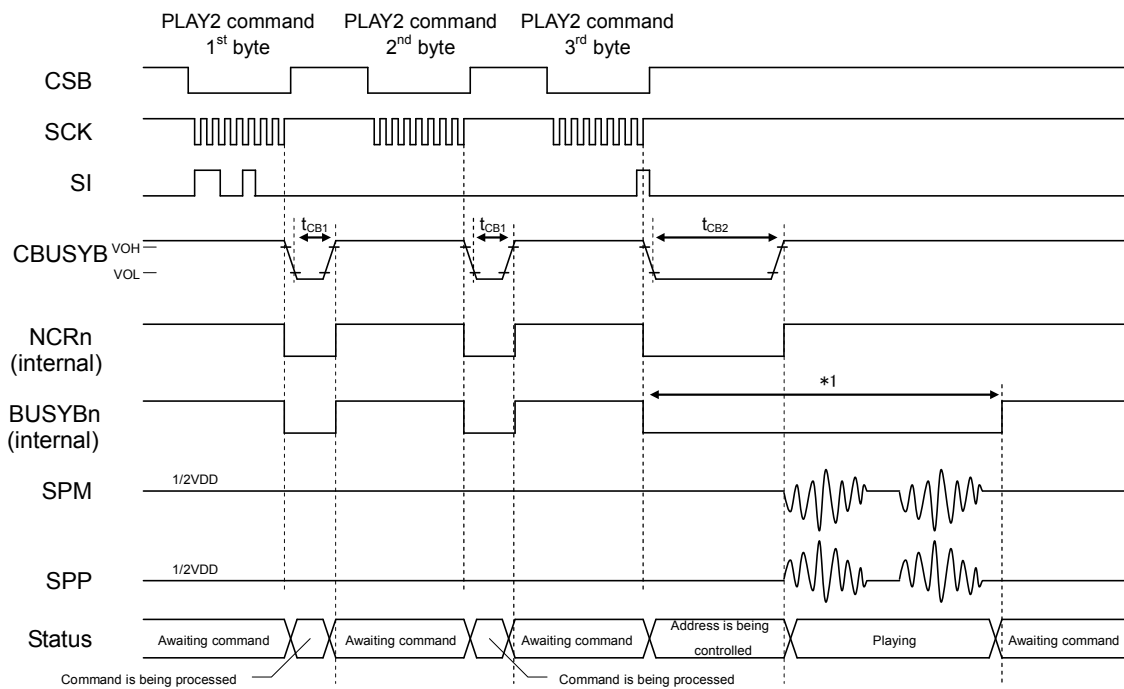

When the first byte of the PLAY command is input, the 2nd byte waits for input after the command processing time ( $t_{CB1}$ ), and when the 2nd byte is input, the 3rd byte waits for input after the command processing time ( $t_{CB1}$ ). When the third byte is entered, the address data of the phrase to be played after the command processing time ( $t_{CB2}$ ) is read from the flash memory. When the phrase address data is read, the specified phrase is played back, and when playback is completed, the BUSYB signal of the playback channel becomes "H" level.

The NCR signal goes to the "L" level during playback preparation, and goes to the "H" level when playback preparation is completed and playback starts. When the NCR signal of the playback channel becomes "H" level, the PLAY command of the next phrase to be played can be accepted.

\*1 The length of the "L" interval in the BUSYBn is ( $t_{CB2}$ + sound production time).

◆ Change volume timing by PAN command

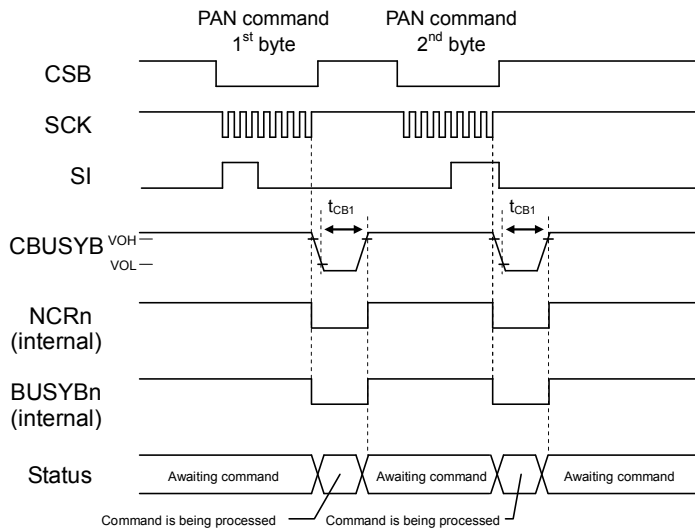

◆ SAICH command timing

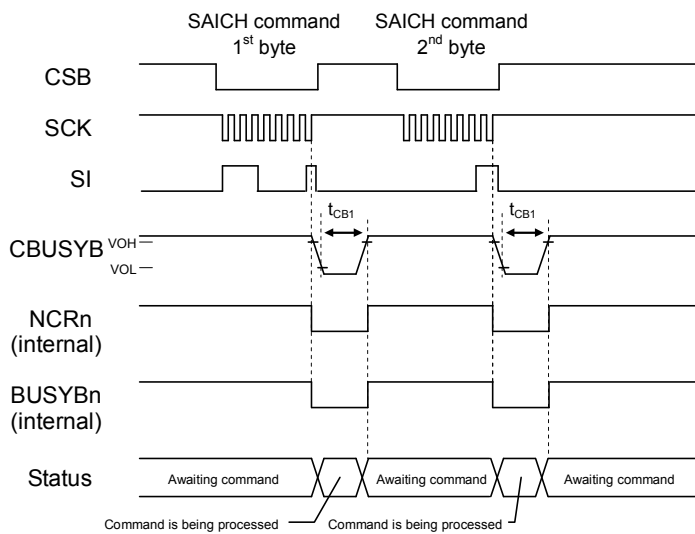

◆ SAICON command timing

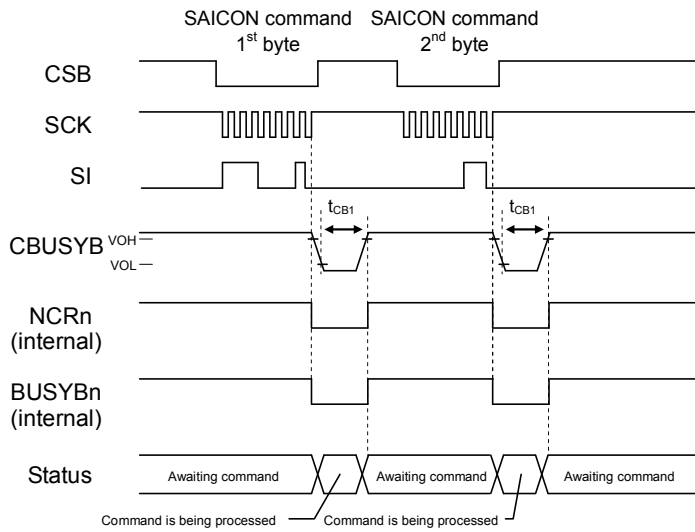

◆ SAITCON command timing

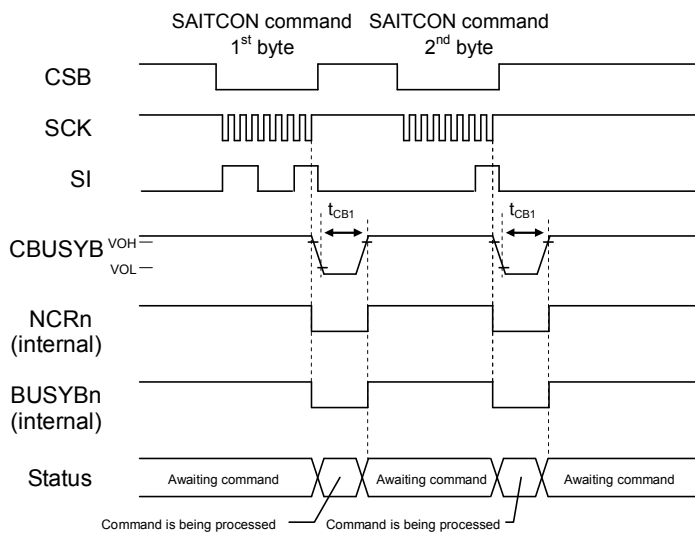

◆ SAIRCON command timing

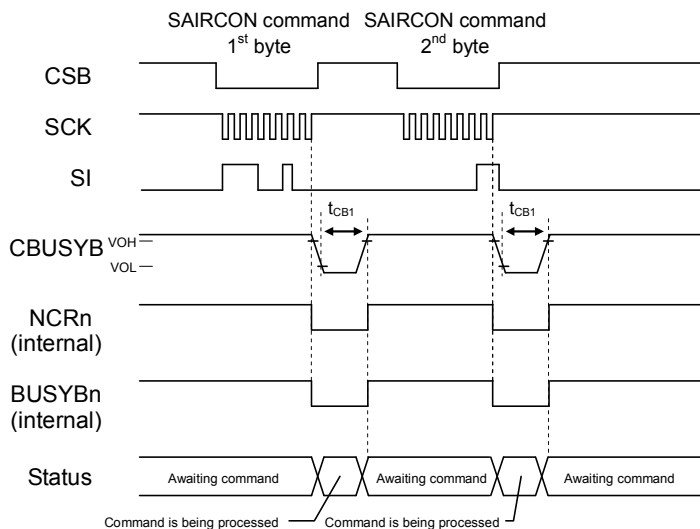

◆ SAIMOD command timing

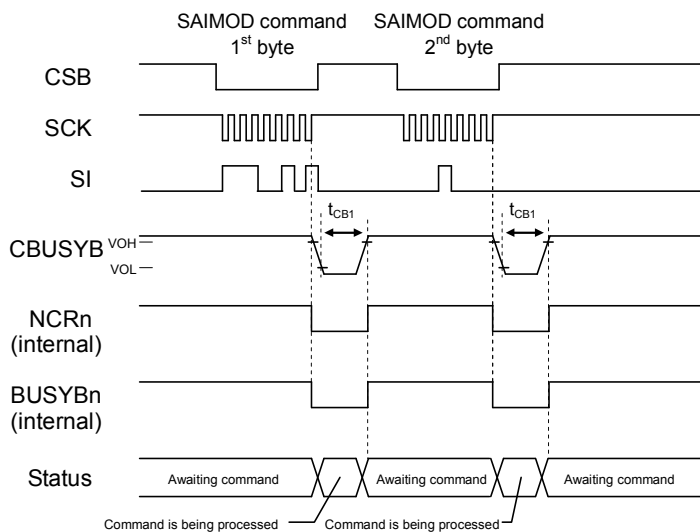

◆ Setting timing by playback sound error detection command

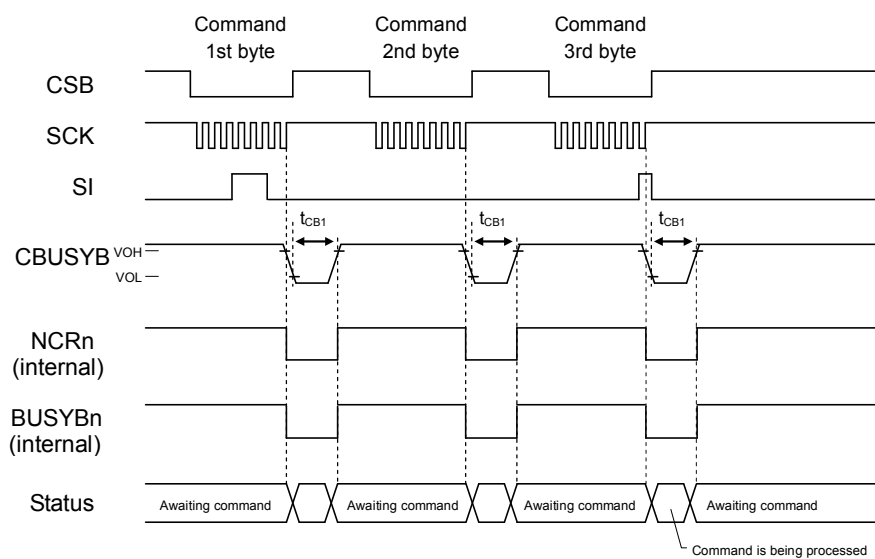

● I<sup>2</sup>C Interface (Slave)

◆ I<sup>2</sup>C Interface Timing

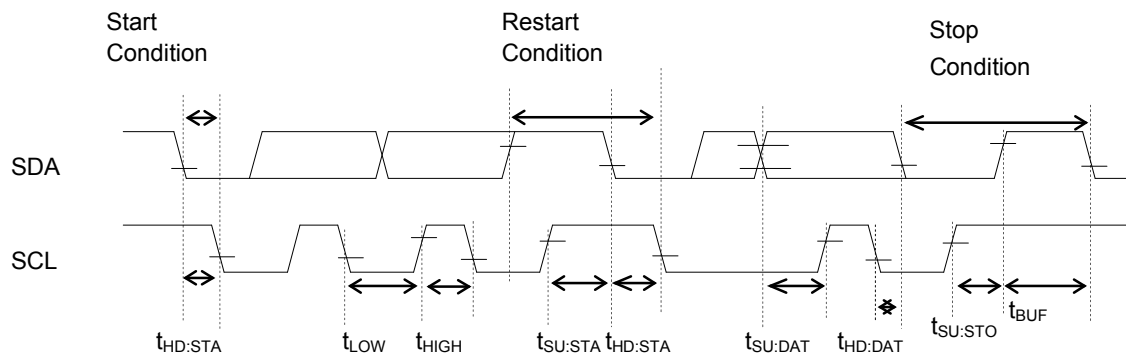

◆ Power-up timing

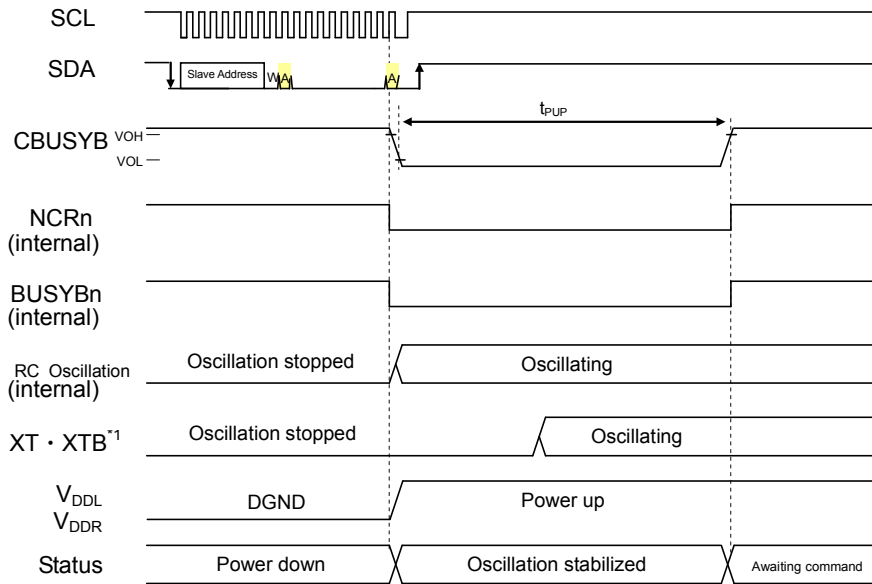

\*1 When using a crystal or ceramic resonator

◆ Power-down timing

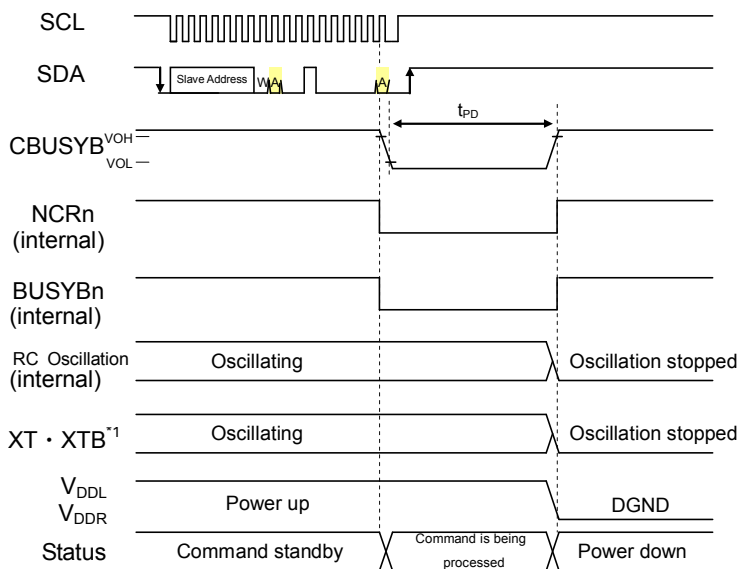

\*1 When using a crystal or ceramic resonator



◆ Speaker amplifier power-up timing (DAMP bit = "0", AEN1 bit = "0", AEN0 bit = "0" → "1")

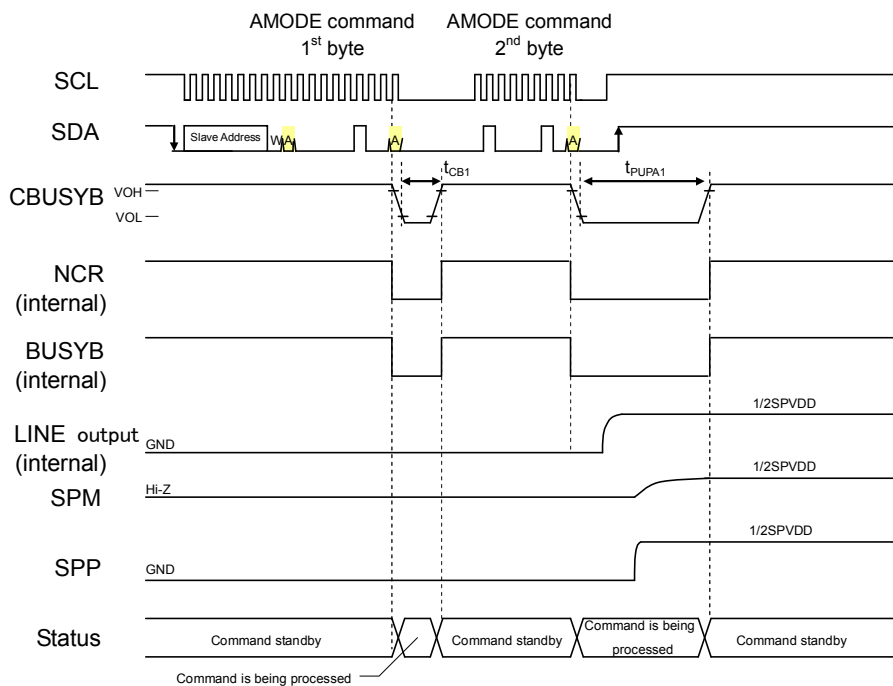

◆ Line amplifier power-up timing (DAMP bit = "0", POP bit = "1", AEN1 bit = "0" → "1", AEN0 bit = "0")

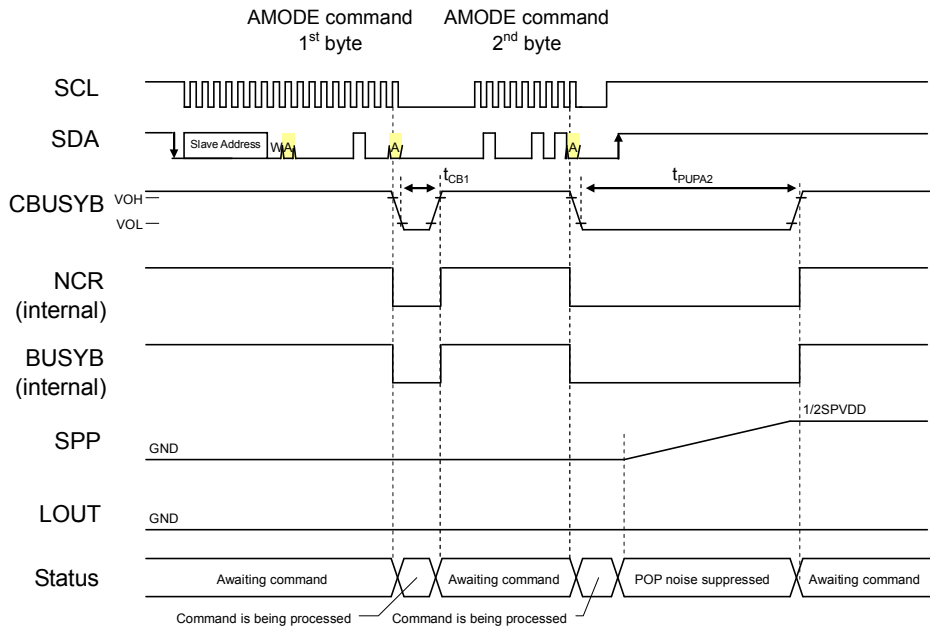

◆ Line amplifier power-up timing (DAMP bit = "0", POP bit = "0", AEN1 bit = "0" → "1", AEN0 bit = "0")

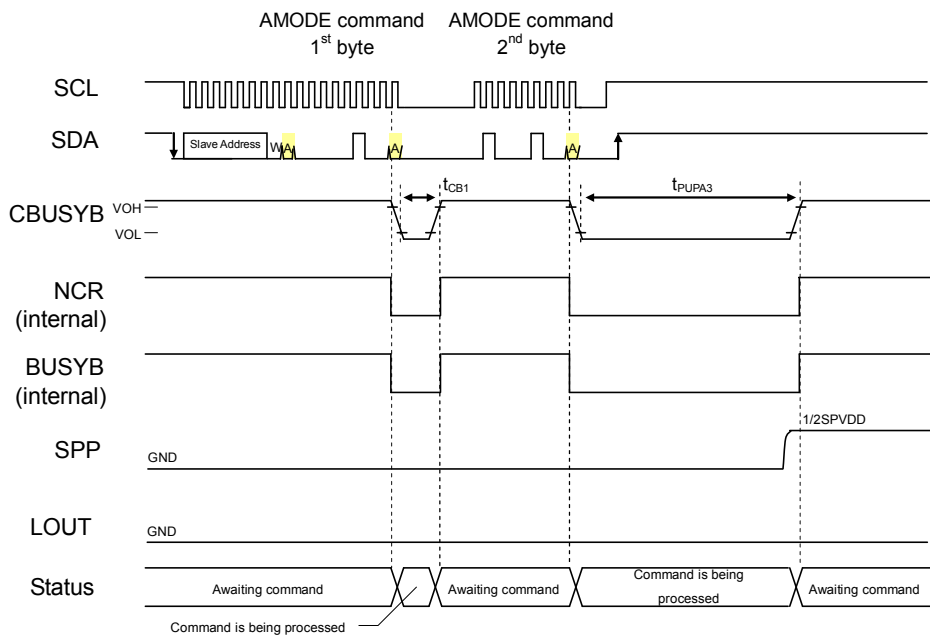

◆ Line amplifier power-up timing (DAMP bit = "0", POP bit = "1", AEN1 bit = "0" → "1", AEN0 bit = "0" → "1")

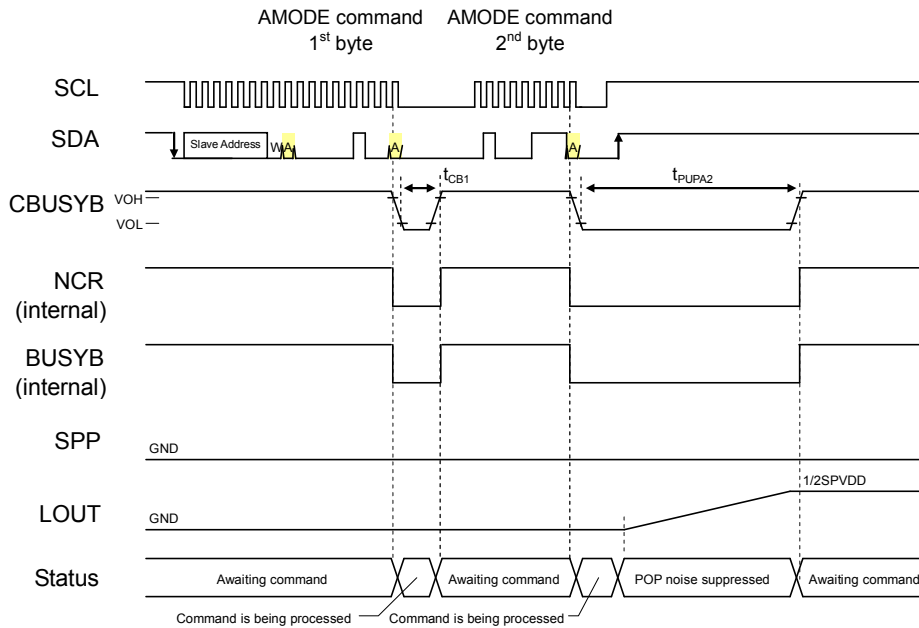

◆ Line amplifier power-up timing (DAMP bit = "0", POP bit = "0", AEN1 bit = "0" → "1", AEN0 bit = "0" → "1")

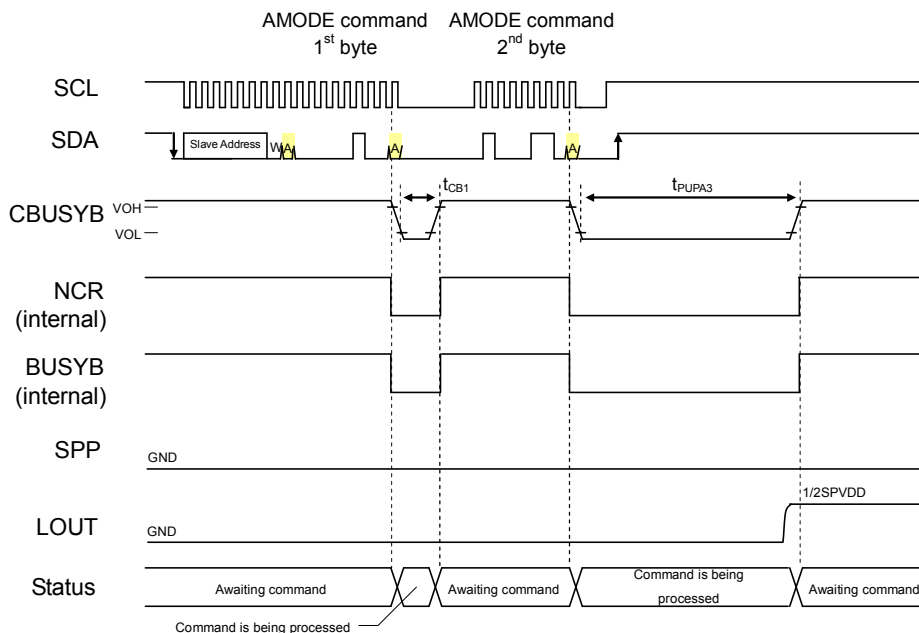

◆ Speaker amplifier power-down timing (DAMP bit = "0", AEN1 bit = "0", AEN0 bit = "1" → "0")

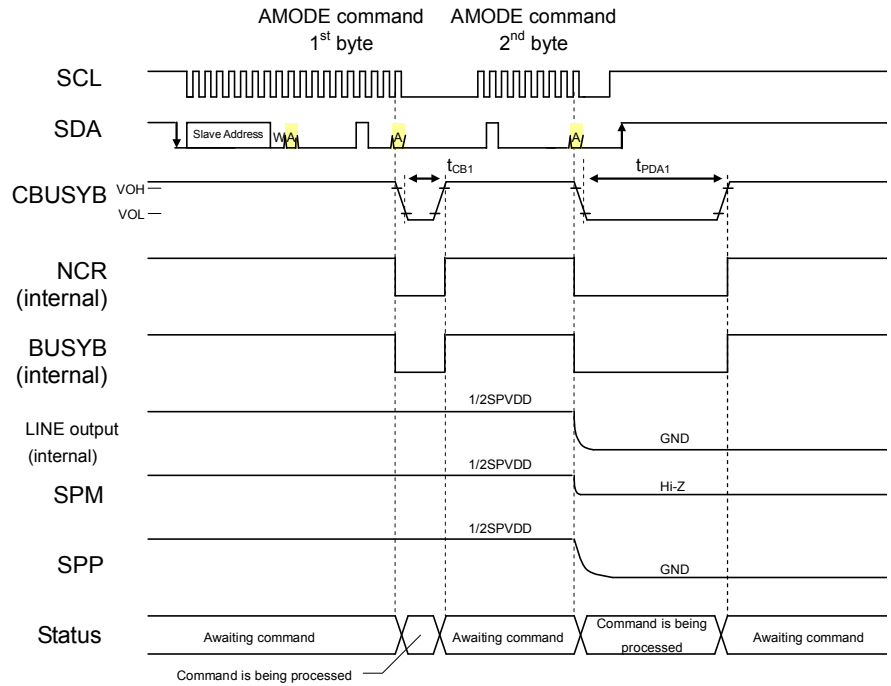

◆ Line amplifier power-down timing (DAMP bit = "0", POP bit = "1", AEN1 bit = "1" → "0", AEN0 bit = "0")

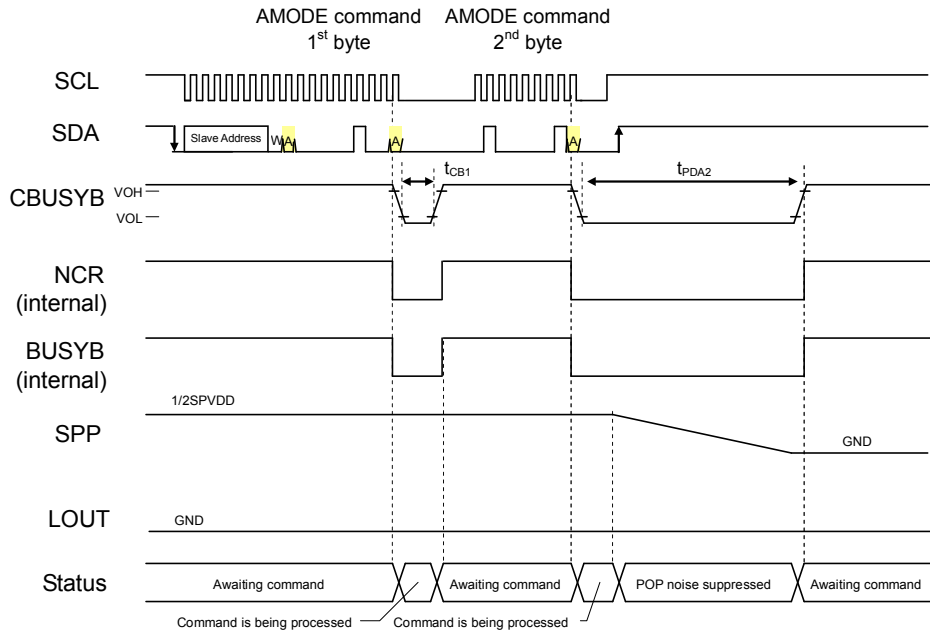

◆ Line amplifier power-down timing (DAMP bit = "0", POP bit = "0", AEN1 bit = "1" → "0", AEN0 bit = "0")

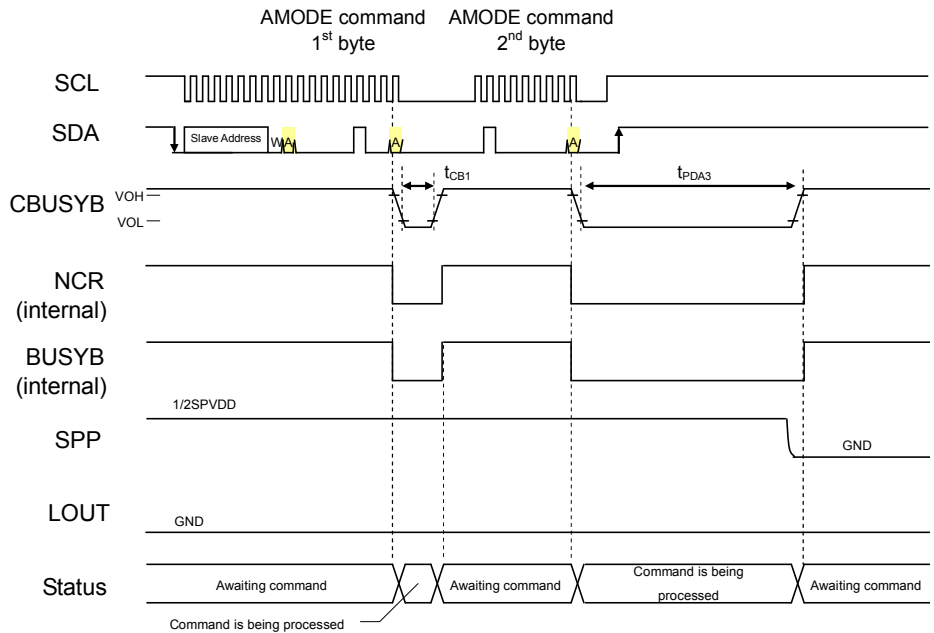

◆ Line amplifier power-down timing (DAMP bit = "0", POP bit = "1", AEN1 bit = "1" → "0", AEN0 bit = "1" → "0")

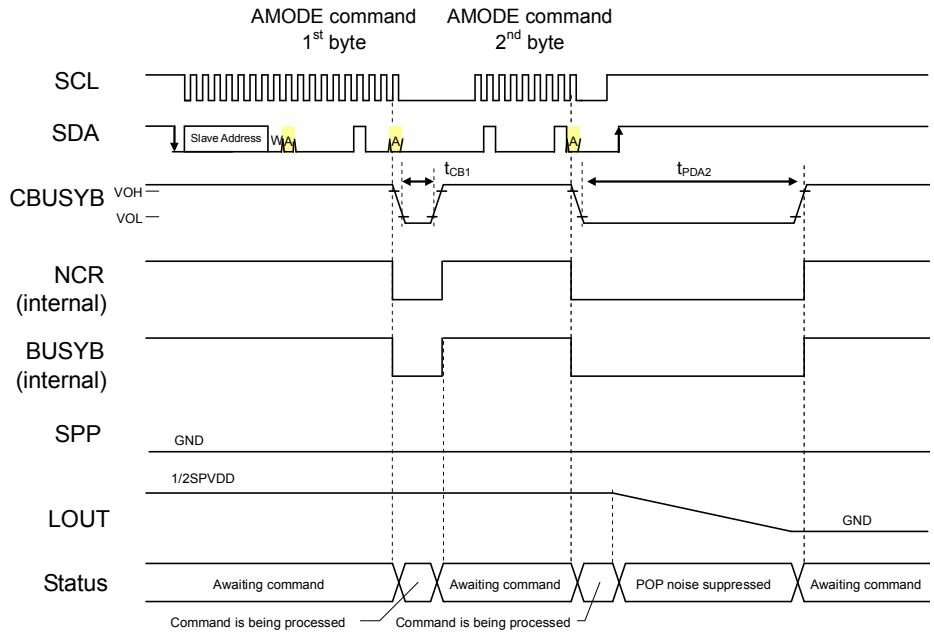

◆ Line amplifier power-down timing (DAMP bit = "0", POP bit = "0", AEN1 bit = "1" → "0", AEN0 bit = "1" → "0")

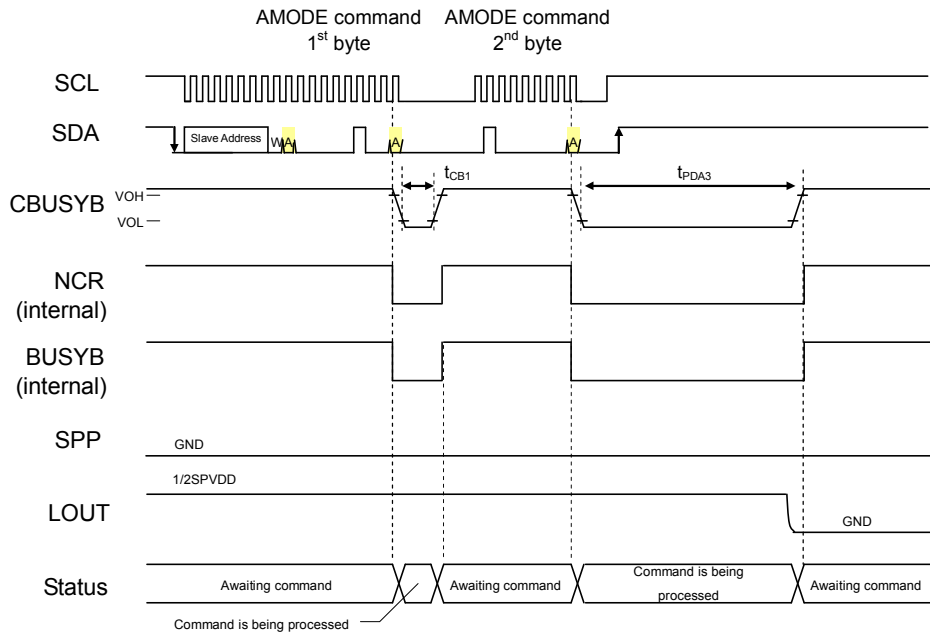

◆ WDTCL command timing

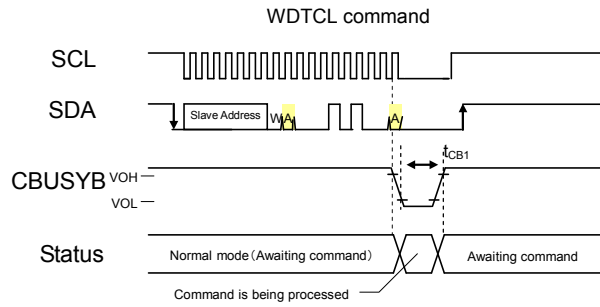

◆ Change volume timing by AVOL command

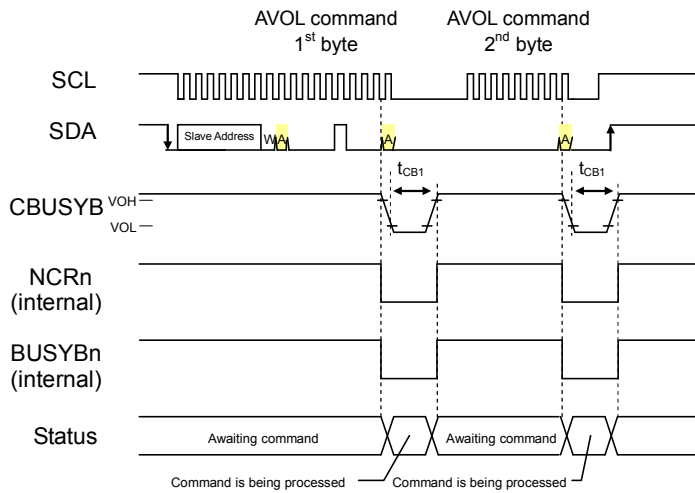

Speaker amplifier volume setting by AVOL commands is valid only when Class AB speaker amplifier is used. When a Class D speaker amplifier is used, the setting value is ignored and +0.0dB is selected.

◆ FADE command timing

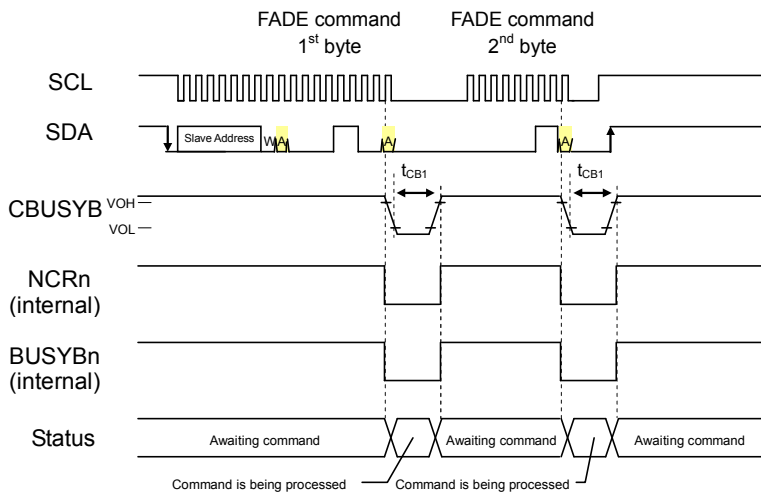



◆ Setting playback phrases using FADR command

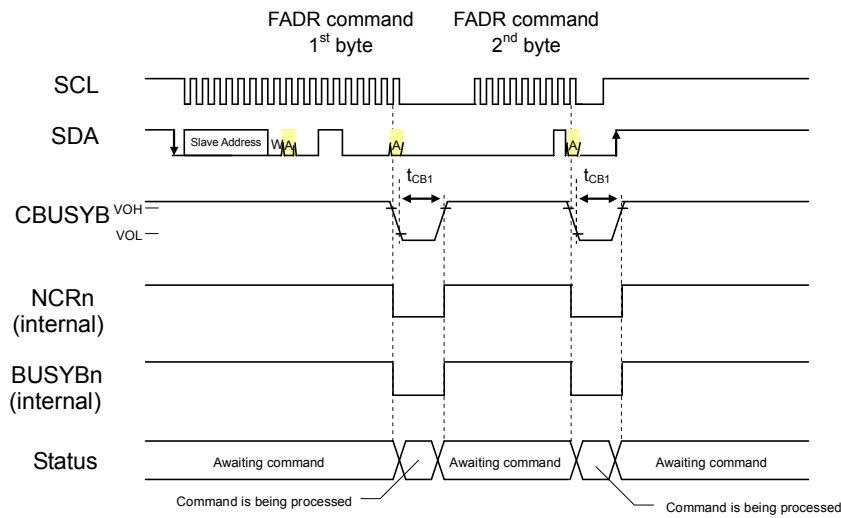

◆ Playback start timing by PLAY command

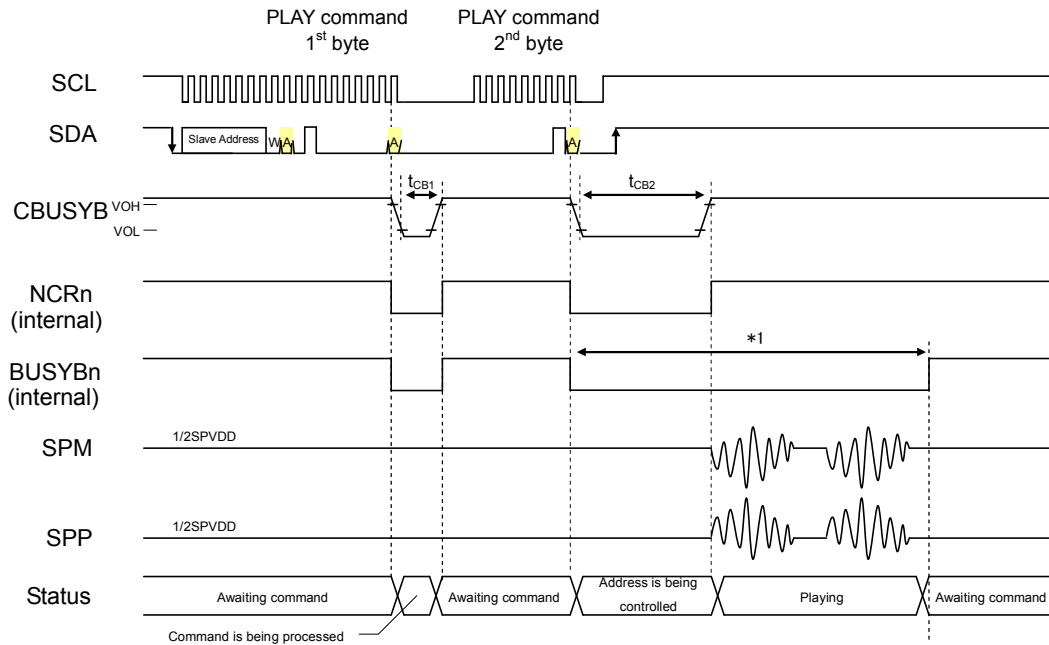

When the first byte of the PLAY command is input, the device waits for the input of the second byte after the command processing time ( $t_{CB1}$ ). When the second byte is entered, the address data of the phrase to be played after the command processing time ( $t_{CB2}$ ) is read from the flash memory.

When the phrase address data is read, the specified phrase is played back, and when playback is completed, the BUSYB signal of the playback channel becomes "H" level.

The NCR signal goes to the "L" level during playback preparation, and goes to the "H" level when playback preparation is completed and playback starts. When the NCR signal of the playback channel becomes "H" level, the PLAY command of the next phrase to be played can be accepted.

\*1 The length of the "L" interval in the BUSYBn is ( $t_{CB2} +$  sound production time).

◆ Continuous playback timing by PLAY command

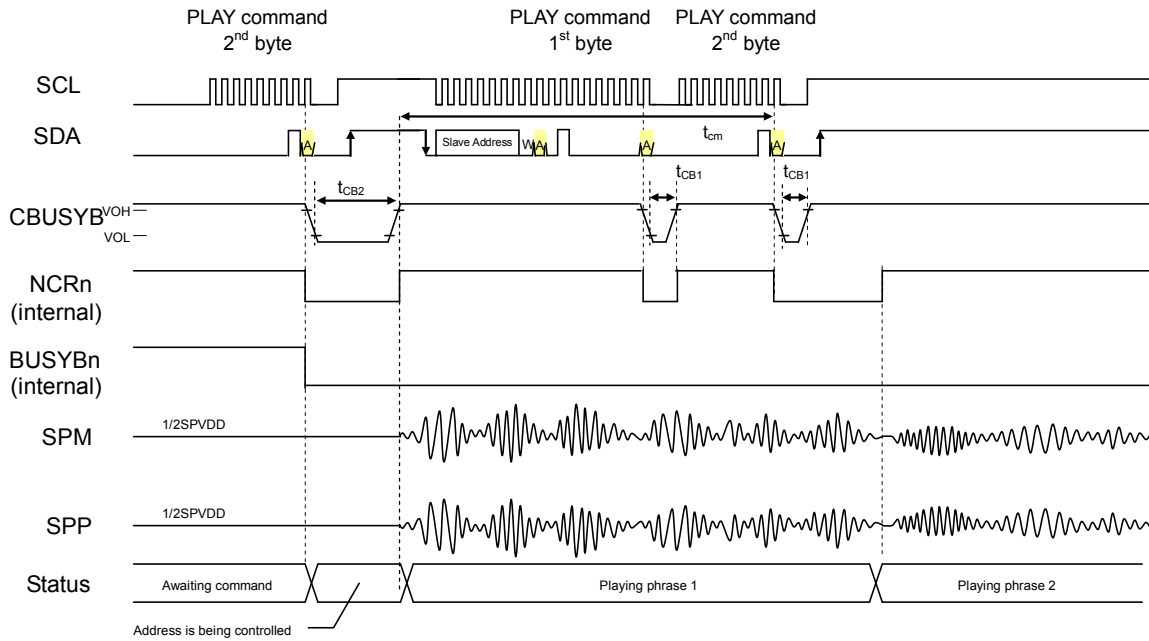

When making continuous playbacks, input the PLAY command for the next phrases within the specified time period ( $t_{cm}$ ) after the NCR of the corresponding channel changes to "H" level, so that the LSI plays back the next phrases without silence sounds after the current phrase playback ends.

When the playback is not continuous, input the PLAY command for the next phrases after confirming the playback is completed by RDSTAT command, etc.

◆ Playback start timing by START command

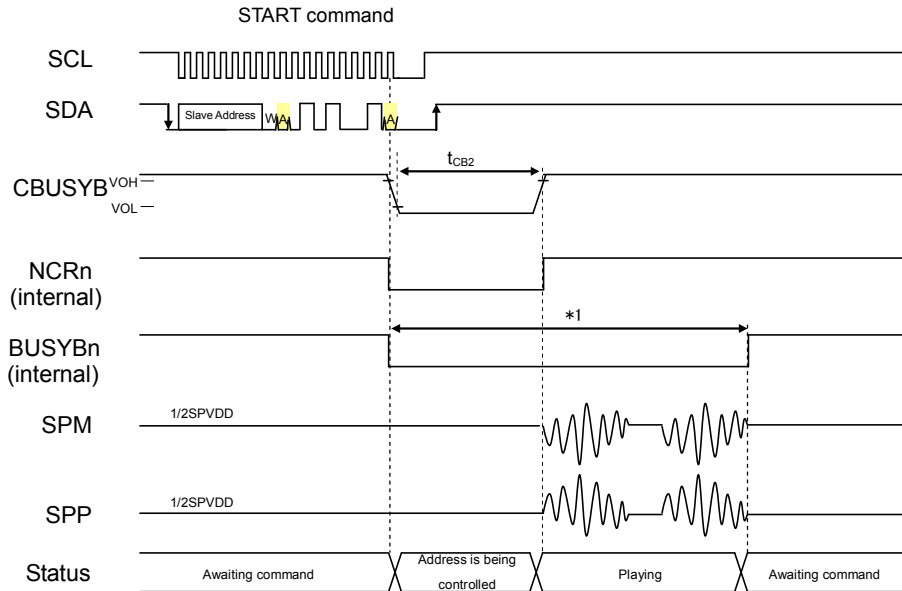

When the START command is input, the address data of the phrase to be played after the command processing time ( $t_{CB2}$ ) is read from the flash memory. When the phrase address data is read, the specified phrase is played back, and when playback is completed, the BUSYB signal of the playback channel becomes "H" level.

The NCR signal goes to the "L" level during playback preparation, and goes to the "H" level when playback preparation is completed and playback starts. When the NCR signal of the playback channel becomes "H" level, the START command of the next phrase to be played can be accepted.

\*1 The length of the "L" interval in the BUSYBn is ( $t_{CB2}$ + sound production time).

◆ Continuous playback timing by START command

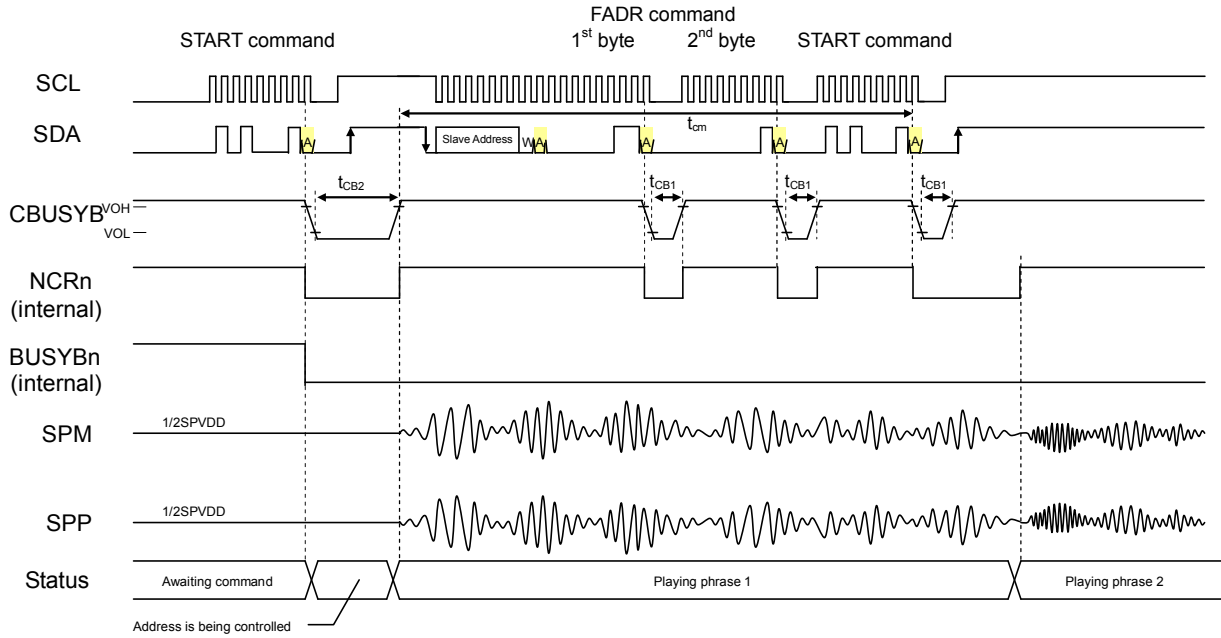

When making continuous playbacks, input the START command for the next phrases within the specified time period ( $t_{cm}$ ) after the NCR of the corresponding channel changes to "H" level, so that the LSI plays back the next phrases without silence sounds after the current phrase playback ends.

When the playback is not continuous, input the START command for the next phrases after confirming the playback is completed by RDSTAT command, etc.

◆ STOP command (when the FAD bit is "L")

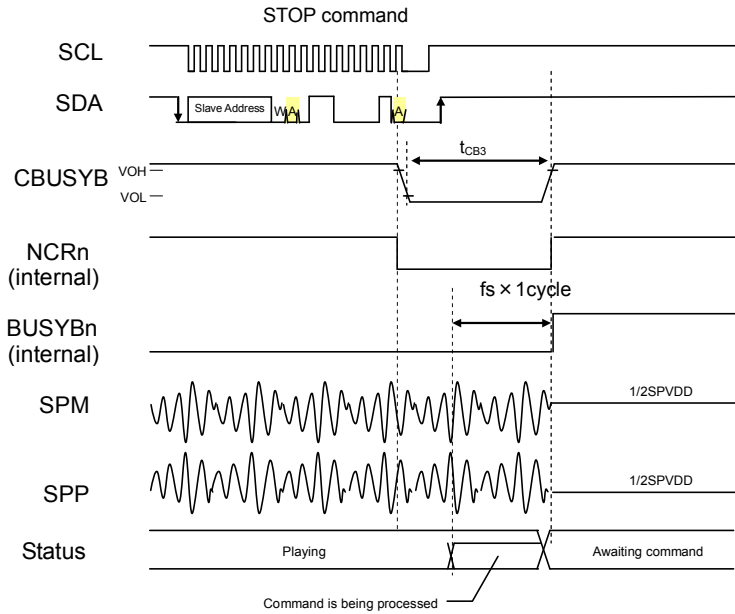

◆ STOP command (when the FAD bit is "H")

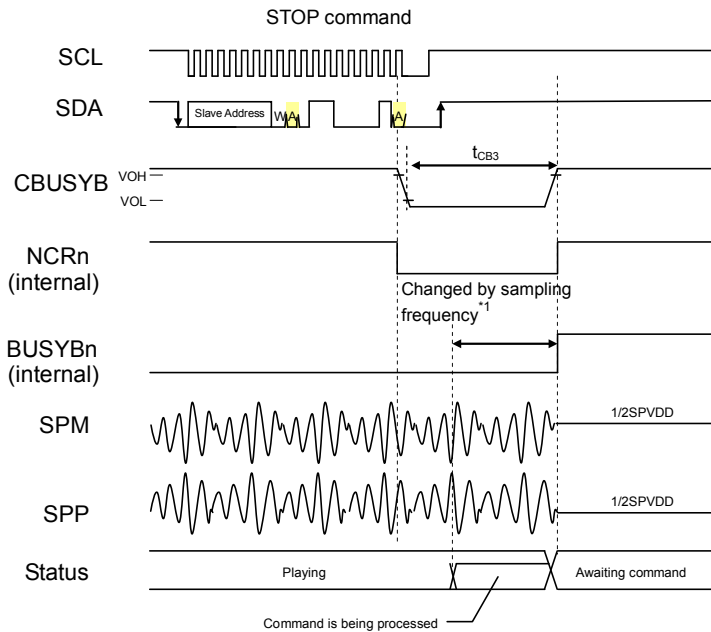

\*1 The duration of the BUSYBn varies depending on the sampling frequency groups.

|                         |                 |
|-------------------------|-----------------|
| At 10.7/21.3kHz         | : Approx. 3ms   |
| At 6.4/12.8/25.6kHz     | : Approx. 5ms   |
| At 8.0/16.0/32.0kHz     | : Approx. 4ms   |
| At 11.025/22.05/44.1kHz | : Approx. 2.9ms |
| At 12.0/24.0/48.0kHz    | : Approx. 2.7ms |

◆ Playback start timing by MUON command

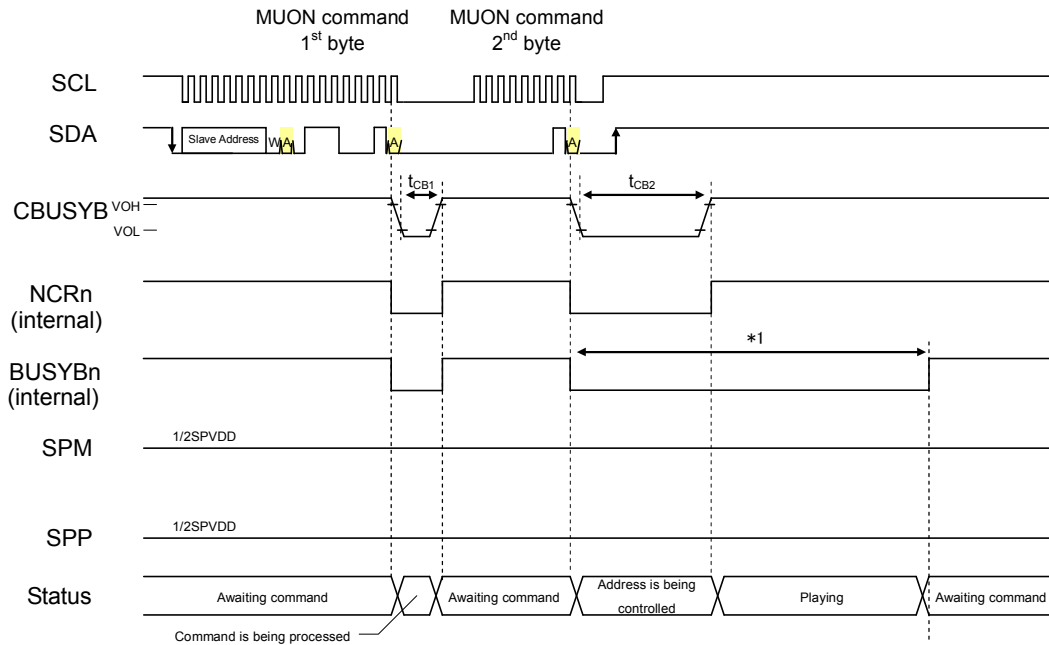

When the first byte of the MUON command is input, the device waits for the input of the second byte after the command processing time ( $t_{CB1}$ ). When the second byte is entered, the silence time is calculated after the command processing time ( $t_{CB2}$ ). When the calculation of the silence duration is completed, the calculated silence is played back, and when the playback is completed, the BUSYB signals of the playback channels become "H" level.

The NCR signal becomes "L" level during playback preparation, and becomes "H" level when playback preparation is completed and playback starts. When the NCR signal of the playback channel becomes "H" level, the PLAY command of the next phrase to be played can be accepted.

\*1 The length of the "L" interval of the BUSYBn is ( $t_{CB2}$  + silence playback time).

◆ Continuous playback timing by MUON command

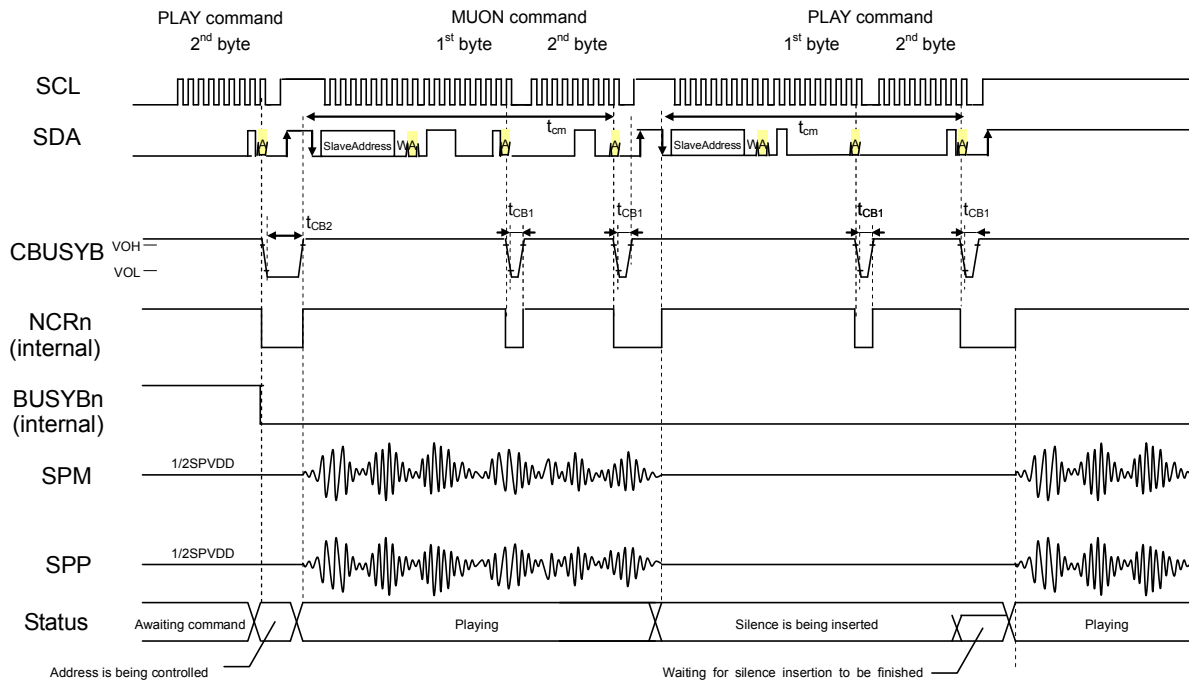

After the PLAY command is input, the CBUSYB signal and NCR signal change to "H" level when the address management of phrase 1 is completed and start playing back. Input the MUON command after the CBUSYB signal changed to "H" level. After the MUON command is received, the LSI is in a state waiting for the end of playback of phrase 1 and the NCR signal remains "L" level until the end of playback.

When the playback of phrase 1 ends, playback of the silence sound starts and the NCR signal changes to "H" level. After the NCR signal of the corresponding channel changes to "H" level, send the PLAY command again to playback the phrase 1. The NCR signal changes to "L" level again after the PLAY command is received and the LSI is in a state waiting for the end of the playback of silence sound.

After ending the playback of silence sound and starting the playback of phrase 1, the NCR signal changes to "H" level and LSI is in state that accepts the next PLAY or MUON command. The BUSYB signal remains "L" level until the sequence of playback is completed.

When making continuous playbacks, input the MUON/PLAY/START command for the next phrases within 10ms ( $t_{cm}$ ) after the NCR of the corresponding channel changes to "H" level.

When the playback is not continuous, input the MUON/PLAY/START command for the next phrases after confirming the playback is completed by RDSTAT command, etc.



◆ Repeat playback setting/release timing by SLOOP/CLOOP command

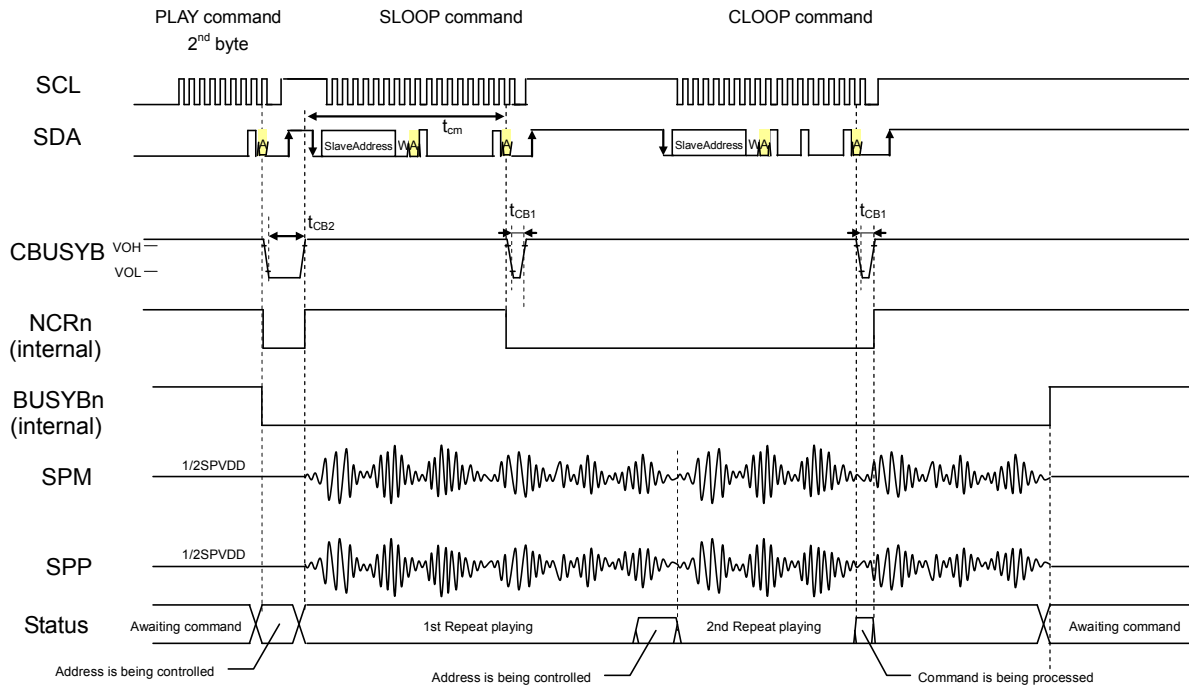

The SLOOP command is valid only during playback. After the PLAY command is input, input the SLOOP command within the specified period ( $t_{cm}$ ) after the NCR of the corresponding channel becomes "H" level. This enables the SLOOP command and repeats playback. While the repeat playback mode is set, the NCR signal is "L" level.

◆ Change volume timing by CVOL command

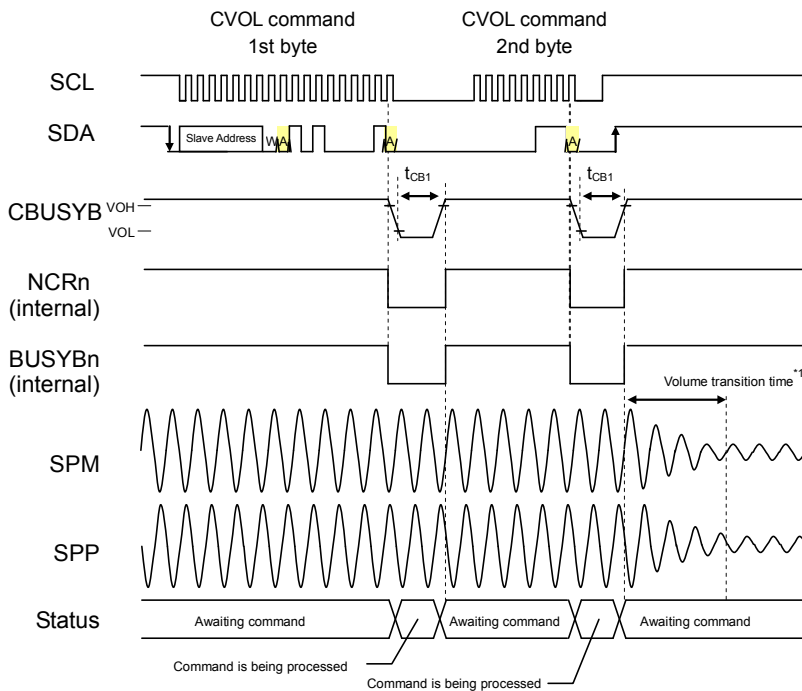

\*1 Refer to the "FADE command" for more information on volume-transition time.

◆ RDSTAT command timing

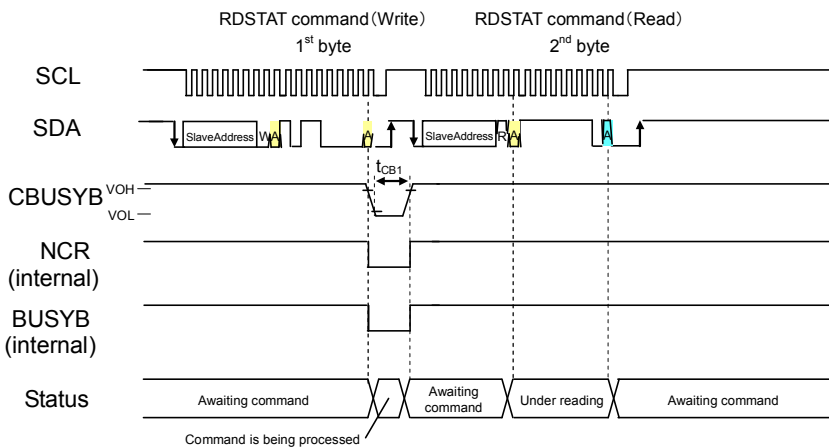

◆ RDVER command timing

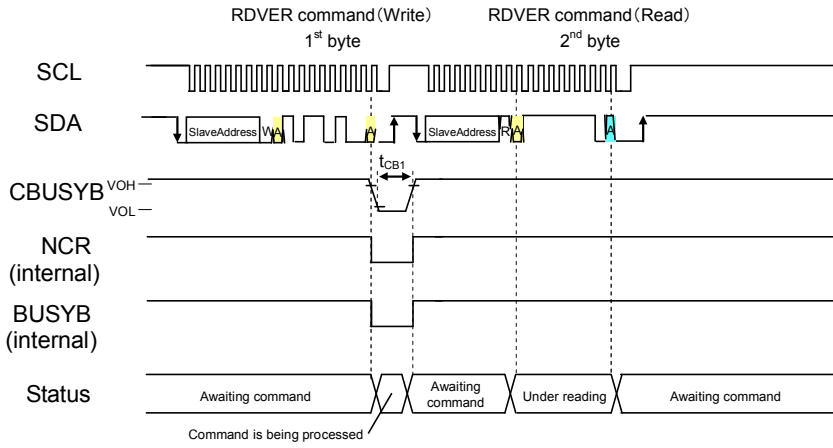

◆ RDERR command timing

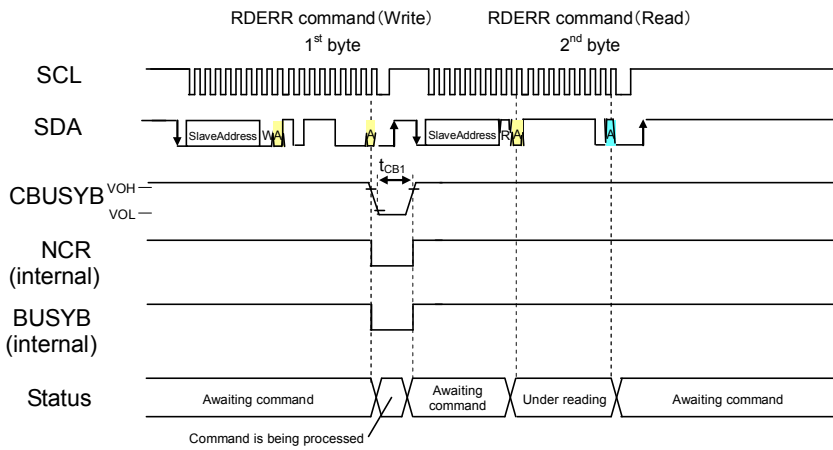

◆ OUTSTAT command timing

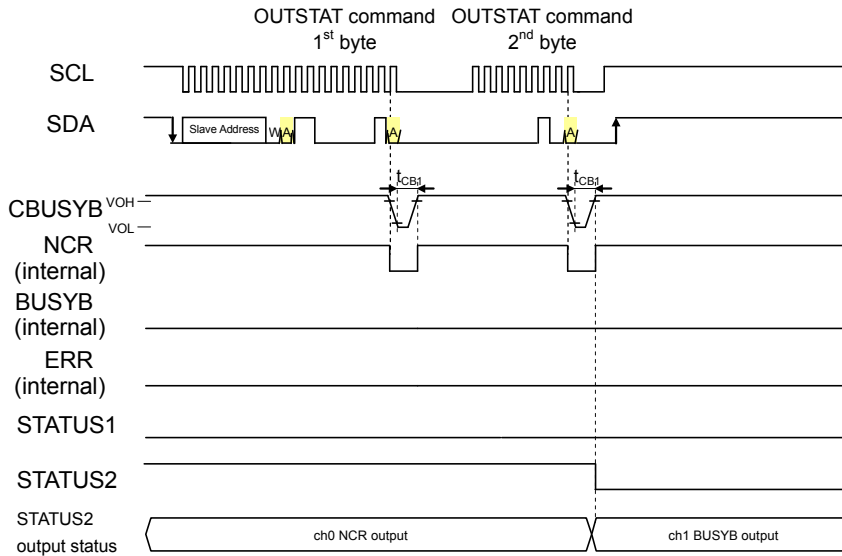

◆ SAFE command timing

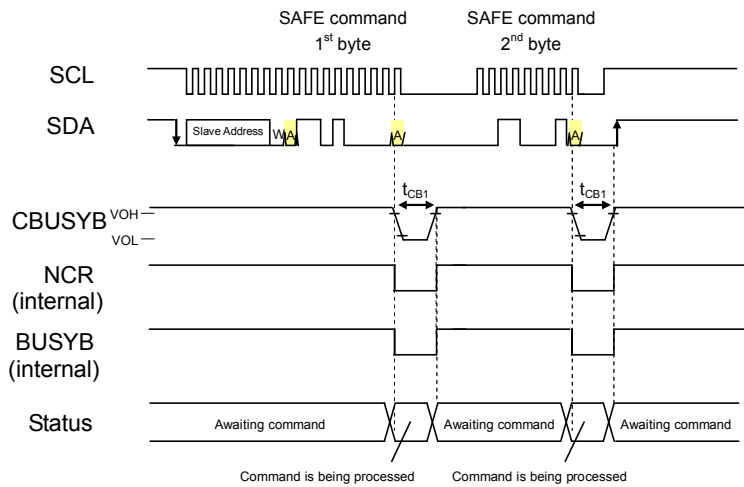

◆ ERRCL command timing

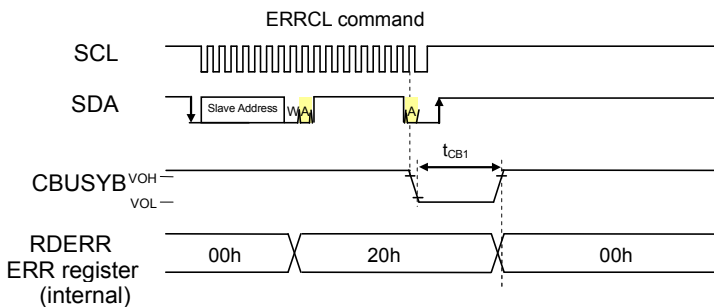

◆ Setting timing of playback phrases by FADR2 command

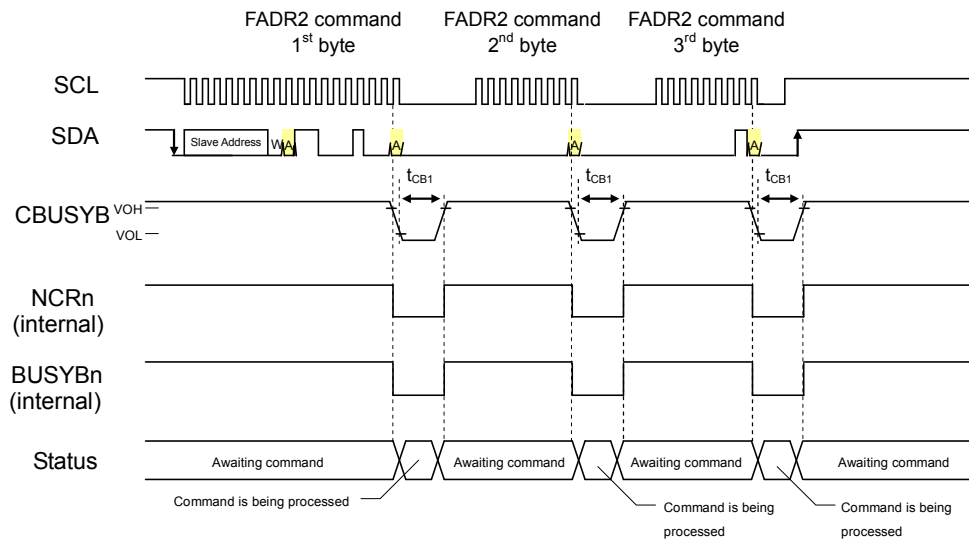

◆ Playback start timing by PLAY2 command

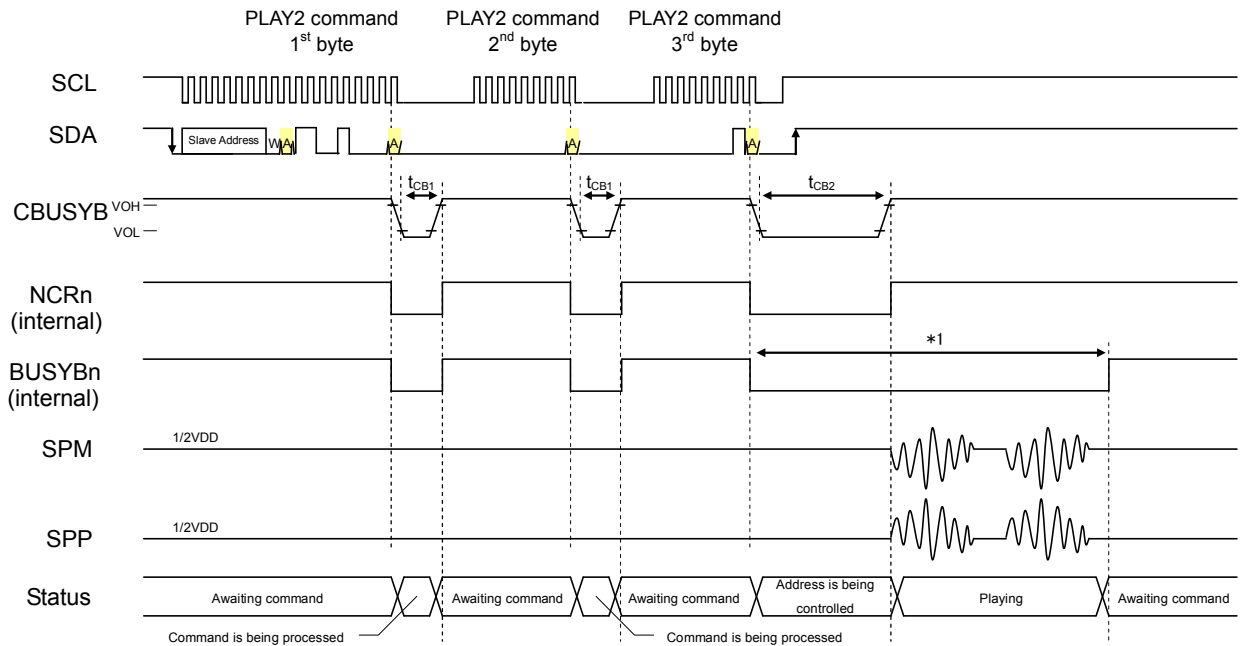

When the first byte of the PLAY command is input, the 2nd byte waits for input after the command processing time ( $t_{CB1}$ ), and when the 2nd byte is input, the 3rd byte waits for input after the command processing time ( $t_{CB1}$ ). When the third byte is entered, the address data of the phrase to be played after the command processing time ( $t_{CB2}$ ) is read from the flash memory. When the phrase address data is read, the specified phrase is played back, and when playback is completed, the BUSYB signal of the playback channel becomes "H" level.

The NCR signal goes to the "L" level during playback preparation, and goes to the "H" level when playback preparation is completed and playback starts. When the NCR signal of the playback channel becomes "H" level, the PLAY command of the next phrase to be played can be accepted.

\*1 The length of the "L" interval in the BUSYBn is ( $t_{CB2}$ + sound production time).

◆ Change volume timing by PAN command

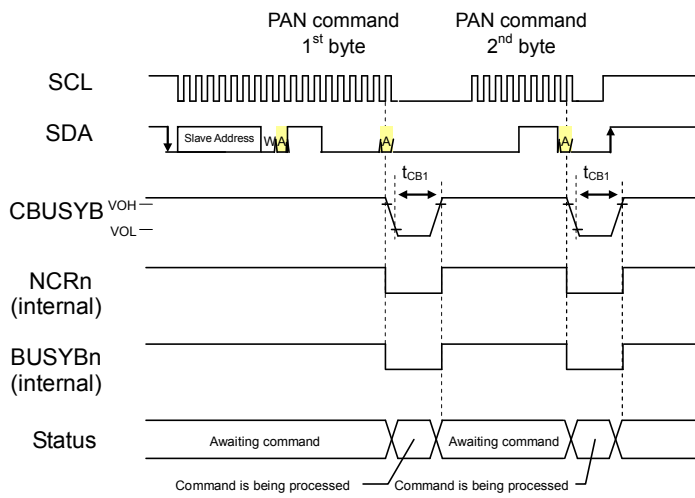

◆ SAICH command timing

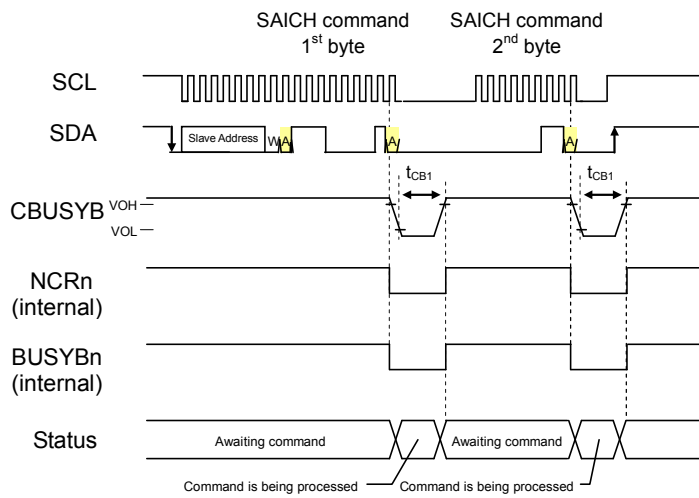

◆ SAICON command timing

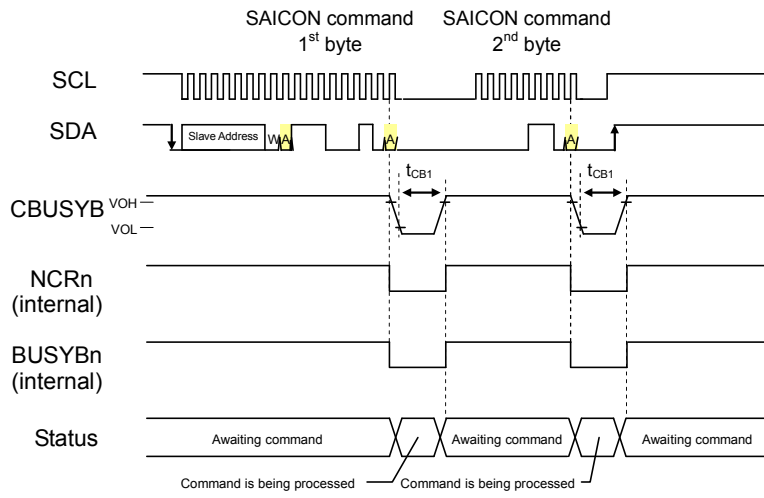

◆ SAITCON command timing

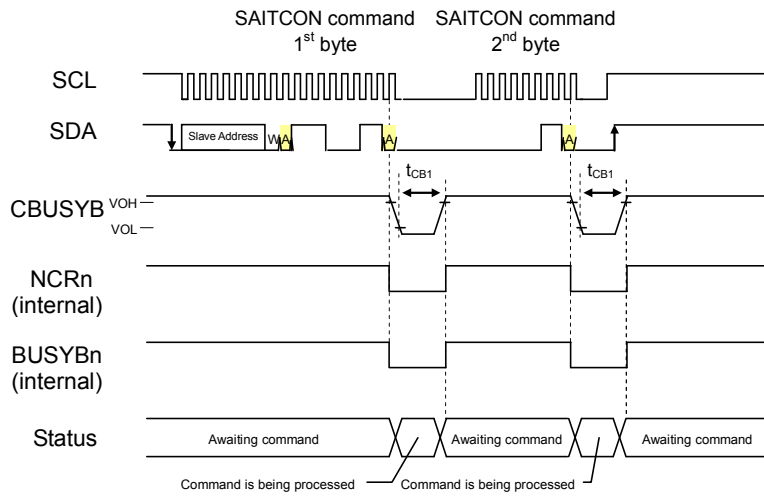

◆ SAIRCON command timing

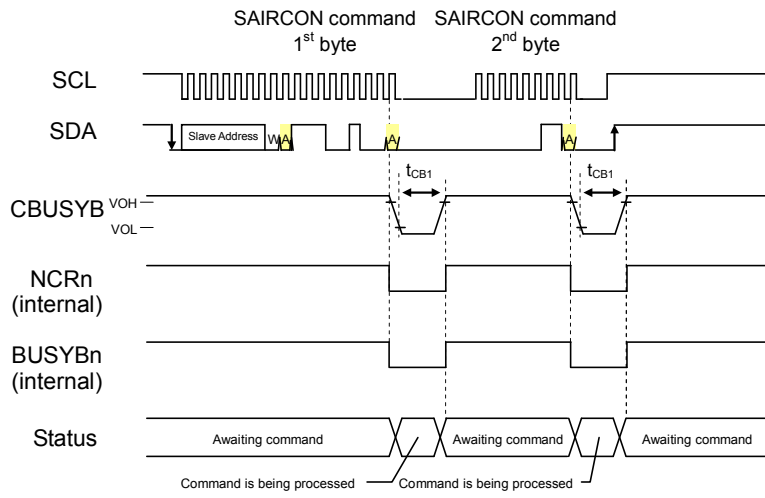

◆ SAIMOD command timing

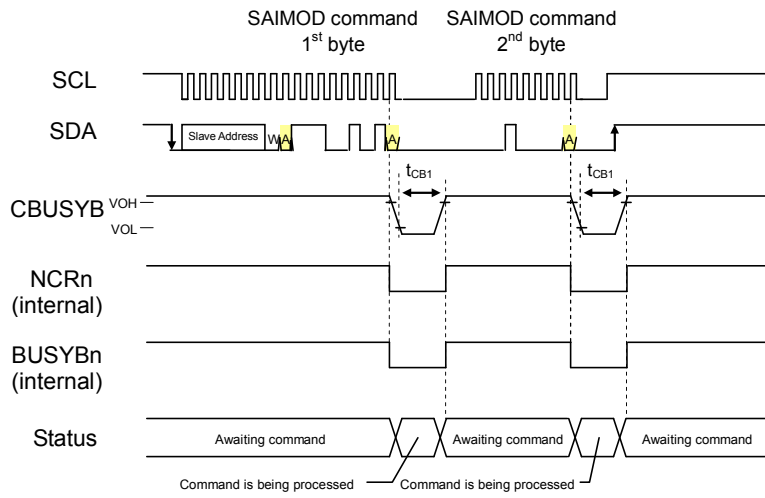



◆ Setting timing by playback sound error detection command

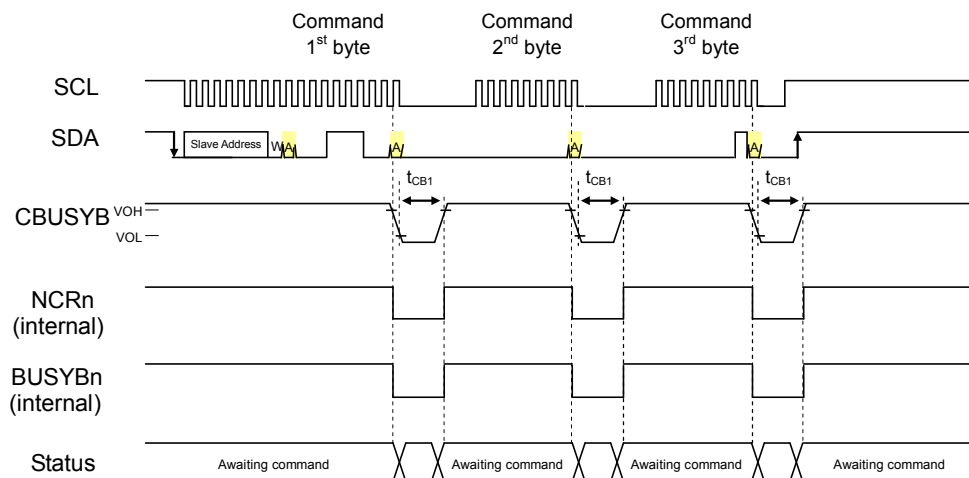

## ■ Command

### ● Command list

Each command is configured in 1-byte (8-bit) units. The PUP, WDTCL, PDWN, START, STOP, SLOOP, CLOOP and ERRCL commands are configured by one byte, the FADR2 and PLAY2 command and playback sound error detection command group are configured by three bytes, and the other commands are configured by two bytes.

Do not enter command that is not described in this manual. Enter the command with the CBUSYB "H".

| Command name | D7                | D6                 | D5                 | D4                | D3      | D2      | D1      | D0                |
|--------------|-------------------|--------------------|--------------------|-------------------|---------|---------|---------|-------------------|
| PUP          | 0                 | 0                  | 0                  | 0                 | 0       | 0       | 0       | WCM               |
| AMODE        | 0                 | 0                  | 0                  | 0                 | 0       | 1       | DAMP    | HPF               |
|              | FAD               | DAG1               | DAG0               | AIG1              | AIG0    | AEN1    | AEN0    | POP               |
| AVOL         | 0                 | 0                  | 0                  | 0                 | 1       | 0       | 0       | 0                 |
|              | 0                 | 0                  | AV5                | AV4               | AV3     | AV2     | 0       | 0                 |
| FADE         | 0                 | 0                  | 0                  | 0                 | 1       | 1       | 0       | 0                 |
|              | 0                 | 0                  | 0                  | 0                 | FCON2   | FCON1   | FCON0   | FADE              |
| FDIRECT      | 0                 | 0                  | 0                  | 1                 | 0       | 0       | 0       | 0                 |
|              | PRT7              | PRT6               | PRT5               | PRT4              | PRT3    | PRT2    | PRT1    | PRT0              |
| WDTCL        | 0                 | 0                  | 0                  | 1                 | 0       | 1       | 0       | 0                 |
| PDWN         | 0                 | 0                  | 1                  | 0                 | 0       | 0       | 0       | 0                 |
| FADR         | 0                 | 0                  | 1                  | 1                 | F9      | F8      | C1      | C0                |
|              | F7                | F6                 | F5                 | F4                | F3      | F2      | F1      | F0                |
| PLAY         | 0                 | 1                  | 0                  | 0                 | F9      | F8      | C1      | C0                |
|              | F7                | F6                 | F5                 | F4                | F3      | F2      | F1      | F0                |
| START        | 0                 | 1                  | 0                  | 1                 | CH3     | CH2     | CH1     | CH0               |
| STOP         | 0                 | 1                  | 1                  | 0                 | CH3     | CH2     | CH1     | CH0               |
| MUON         | 0                 | 1                  | 1                  | 1                 | CH3     | CH2     | CH1     | CH0               |
|              | M7                | M6                 | M5                 | M4                | M3      | M2      | M1      | M0                |
| SLOOP        | 1                 | 0                  | 0                  | 0                 | CH3     | CH2     | CH1     | CH0               |
| CLOOP        | 1                 | 0                  | 0                  | 1                 | CH3     | CH2     | CH1     | CH0               |
| CVOL         | 1                 | 0                  | 1                  | 0                 | CH3     | CH2     | CH1     | CH0               |
|              | 0                 | CV1                | CV0                | CV6               | CV5     | CV4     | CV3     | CV2               |
| RDSTAT       | 1                 | 0                  | 1                  | 1                 | 0       | 0       | 0       | 0                 |
|              | BUSYB3            | BUSYB2             | BUSYB1             | BUSYB0            | NCR3    | NCR2    | NCR1    | NCR0              |
| RDVER        | 1                 | 0                  | 1                  | 1                 | 0       | 1       | 0       | 0                 |
|              | VER7              | VER6               | VER5               | VER4              | VER3    | VER2    | VER1    | VER0              |
| RDERR        | 1                 | 0                  | 1                  | 1                 | 1       | 0       | 0       | ERSEL             |
|              | OSCERR/<br>MIXERR | RSTERR/<br>SAINERR | WDTERR/<br>LRCKERR | ROMERR/<br>BCKERR | SPDERR/ | TSDERR/ | DCDERR/ | WCMERR/           |
| OUTSTAT      | 1                 | 1                  | 0                  | 0                 | 0       | 0       | 0       | 0                 |
|              | 0                 | PORT               | STA1               | STA0              | CH3     | CH2     | CH1     | CH0               |
| FADR2        | 1                 | 1                  | 0                  | 0                 | 0       | 1       | 0       | 0                 |
|              | 0                 | 0                  | C1                 | C0                | F11     | F10     | F9      | F8                |
|              | F7                | F6                 | F5                 | F4                | F3      | F2      | F1      | F0                |
| PLAY2        | 1                 | 1                  | 0                  | 0                 | 1       | 0       | 0       | 0                 |
|              | 0                 | 0                  | C1                 | C0                | F11     | F10     | F9      | F8                |
|              | F7                | F6                 | F5                 | F4                | F3      | F2      | F1      | F0                |
| SAFE         | 1                 | 1                  | 0                  | 1                 | 0       | 0       | 0       | ERSEL             |
|              | OSCEN/<br>MIXEN   | RSTEN/<br>SAINEN   | WDTEN/<br>LRCKEN   | ROMEN/<br>BCKEN   | SPDEN/  | TSDEN/  | DCDEN/  | WCMEN/<br>WVDIFEN |
| ERRCL        | 1                 | 1                  | 1                  | 1                 | 1       | 1       | 1       | 1                 |

| Command name | D7  | D6  | D5  | D4   | D3     | D2   | D1   | D0    |
|--------------|-----|-----|-----|------|--------|------|------|-------|
| PAN          | 1   | 1   | 1   | 1    | 0      | 0    | C1   | C0    |
|              | R3  | R2  | R1  | R0   | L3     | L2   | L1   | L0    |
| SAICH        | 1   | 1   | 1   | 0    | 0      | 0    | 0    | 1     |
|              | 0   | LC1 | LC0 | LEN  | 0      | RC1  | RC0  | REN   |
| SAICON       | 1   | 1   | 1   | 0    | 0      | 0    | 1    | 0     |
|              | FS3 | FS2 | FS1 | FS0  | 0      | 1    | INEN | OUTEN |
| SAITCON      | 1   | 1   | 1   | 0    | 0      | 0    | 1    | 1     |
|              | BWO | 0   | 0   | MSBO | ISSCKO | AFOO | DLYO | WSLO  |
| SAIRCON      | 1   | 1   | 1   | 0    | 0      | 1    | 0    | 0     |
|              | BWI | 0   | 0   | MSBI | ISSCKI | AFOI | DLYI | WSLI  |
| SAIMOD       | 1   | 1   | 1   | 0    | 0      | 1    | 0    | 1     |
|              | 0   | 0   | 0   | BSWP | 0      | 0    | 0    | MST   |

The playback sound error detection command group is a single command in three bytes, and can be read by setting the RW bit in the first byte to 0, and can be written by setting the RW bit to 1.

| The following is the playback sound error detection command group. |               |               |               |               |               |               |               |               |
|--|---------------|---------------|---------------|---------------|---------------|---------------|---------------|---------------|
| Command name   | D7            | D6            | D5            | D4            | D3            | D2            | D1            | D0            |
| SCMODE   | 0             | 0             | 0             | 1             | 1             | RW            | 0             | 0             |
|  | 0             | 0             | 0             | 0             | 0             | 0             | 0             | 0             |
|  | 1             | 0             | 0             | 0             | 0             | 0             | AINDET        | FBPATH        |
| WVDIFTH  | 0             | 0             | 0             | 1             | 1             | RW            | 0             | 0             |
|  | 0             | 0             | 0             | 1             | 1             | 1             | 1             | 0             |
|  | WVDIFS<br>TH3 | WVDIFS<br>TH2 | WVDIFS<br>TH1 | WVDIFS<br>TH0 | WVDIFD<br>TH3 | WVDIFD<br>TH2 | WVDIFD<br>TH1 | WVDIFD<br>TH0 |
|  |               |               |               |               |               |               |               |               |

● Description of Command Functions

◆ PUP command

• Command 

|   |   |   |   |   |   |   |     |
|---|---|---|---|---|---|---|-----|
| 0 | 0 | 0 | 0 | 0 | 0 | 0 | WCM |
|---|---|---|---|---|---|---|-----|

The PUP command shifts from the power-down state to the command standby state.

Since only the PUP command is accepted when the LSI is in the power-down state, the command is ignored if another command is input.

To return to the power-down mode, enter the PDWN command.

The WCM bit is used to set the mode for inputting command and data two-times. When this bit is set to "1", the subsequent command and data inputs are set to the two-times input mode, and the command is accepted only when they match.

If they do not match, the accepted command is discarded. Refer to the "RDSTAT command", "OUTSTAT command", and "SAFE command" for handling when a mismatch occurs.

Even if two-times input modes are used for the I<sup>2</sup>C interface, one-time input is used for the slave address input. If the slave address matches, ACK is returned. If the slave address does not match, NACK is returned. The command is input two-times.

| WCM | Description                                      |
|-----|--|
| 0   | Do not use input mode two-times. (Initial value) |
| 1   | Use the two-times input mode                     |

For the power-up timing by the PUP command, refer to the "Power-up timing" in the timing chart.

## ◆ AMODE command

|           |     |      |      |      |      |      |      |     |          |
|-----------|-----|------|------|------|------|------|------|-----|----------|
| • Command | 0   | 0    | 0    | 0    | 0    | 1    | DAMP | HPF | 1st byte |
|           | FAD | DAG1 | DAG0 | AIG1 | AIG0 | AEN1 | AEN0 | POP | 2nd byte |

The AMODE command sets the analog part.

The AMODE command is ignored during power-down, power-up transition, power-down transition and playback sound. When the PDWN command is input while powering up the analog parts, the LSI power downs on the setting condition when powering up the analog parts by the AMODE command. To perform power-down under a setting condition that differs from the power-up condition of the analog unit, set the AMODE command to set the power-down condition again. To power up the analog part, set the CVOL command to 00h (initial value) and then enter the AMODE command. The settings are initialized when the reset is released or when the PDWN command is inputted.

Each setting is as follows.

| DAMP | Description  |
|------|--|
| 0    | Use Class AB amplifier for speaker amplifier output. |
| 1    | Use Class D amplifier for speaker amplifier output.  |

When using line amplifier and using analog mixing from the AIN pin, set DAMP = "0" (Class AB amplifier is used). In this LSI, select DAMP = "0" (Class AB amplifier is used).

| HPF | Description  |
|-----|--|
| 0   | No high-pass filter is used.                             |
| 1   | Use a high-pass filter with a cut-off frequency of 200Hz |

| FAD | Description  |
|-----|--|
| 0   | Fade-out is not processed when inputting STOP command. |
| 1   | Fade out when inputting STOP command                   |

The fade-out processing BUSYB signal becomes "L" and becomes "H" after processing is completed.

| DAG1 | DAG0 | Description   |
|------|------|---|
| 0    | 0    | Internal DAC signal input OFF                           |
| 0    | 1    | Internal DAC signal input ON (-6 dB)                    |
| 1    | 0    | Internal DAC signal input ON (0dB)                      |
| 1    | 1    | Internal DAC signal input ON (0dB) (setting prohibited) |

The setting is enabled in the speaker amplifier output mode when using Class AB amplifier. Refer to the "Volume Settings" in the "Function description".

| AIG1 | AIG0 | Description   |
|------|------|---|
| 0    | 0    | Analog input from the AIN pin OFF                       |
| 0    | 1    | Analog input from AIN pin ON (-6 dB)                    |
| 1    | 0    | Analog input from AIN pin ON (0dB)                      |
| 1    | 1    | Analog input from AIN pin ON (0dB) (setting prohibited) |

Input the sound signals to the AIN pin after CBUSYB pin becomes "H" by the AMODE command. The setting is enabled in the speaker amplifier output mode only when using Class AB amplifier. Refer to the "Volume Settings" in the "Function description".

| POP | Description                   |
|-----|-------------------------------|
| 0   | Without pop noise suppression |
| 1   | With pop noise suppression    |

This bit is valid when line amplifier output is selected.

When power up with pop noise suppression, the line amplifier output rises from the DGND level to the SG level at the specified time (tPUPA2). When power down with pop noise suppression, the line amplifier output falls from the SG level to the DGND level at the specified time (tPDA2).

When power up without pop noise suppression, the line amplifier output rises from the DGND level to the SG level at the specified time (tPUPA3). When power down without pop noise suppression, the line amplifier output falls from the SG level to the DGND level at the specified time (tPDA3).

The settings of the AEN1/AEN0/POP bits for power-down and power-up of the analog section when the speaker amplifier output and line amplifier output are as follows.

| Mode   | AEN1 | AEN0 | POP | Description  |
|--|------|------|-----|--|
| Speaker amplifier output<br>(Class AB amplifier) | 0    | 0    | *1  | In the power-down state or<br>changeover to the power-down state.                              |
|  | 0    | 1    | *1  | In the power-up state or<br>changeover to the power-up state                                   |
| Line amplifier output<br>(When using SPP pin)    | 0    | 0    | 0   | In the power-down state or<br>changeover to the power-down state without Pop Noise Suppression |
|  | 1    | 0    | 0   | In the power-up state or<br>changeover to the power-up state without Pop Noise Suppression     |
|  | 0    | 0    | 1   | In the power-down state or<br>changeover to the power-down state with pop noise suppression    |
|  | 1    | 0    | 1   | In the power-up state or<br>changeover to the power-up state with pop noise suppression        |
| Line amplifier output<br>(When using LOUT pin)   | 0    | 0    | 0   | In the power-down state or<br>changeover to the power-down state without Pop Noise Suppression |
|  | 1    | 1    | 0   | In the power-up state or<br>changeover to the power-up state without Pop Noise Suppression     |
|  | 0    | 0    | 1   | In the power-down state or<br>changeover to the power-down state with pop noise suppression    |
|  | 1    | 1    | 1   | In the power-up state or<br>changeover to the power-up state with pop noise suppression        |

\*1 Settings can be enabled for both 0 and 1.

Pin states at AMODE power-down are as follows.

| Analog output pin | Condition |
|-------------------|-----------|
| $V_{DDL}$         | 2.5V(typ) |
| $V_{DDR}$         | 3.0V(typ) |
| SG                | DGND      |
| SPM               | HiZ       |
| SPP               | SPGND     |
| LOUT              | DGND      |

The timing of AMODE command is shown in the timing chart.

"Speaker amplifier power-up timing (DAMP bit "0", AEN1 bit "0", AEN0 bit "0" → "1")"

"Line amplifier power-up timing (DAMP bit = "0", POP bit = "1", AEN1 bit = "0" → "1", AEN0 bit = "0")"

"Line amplifier power-up timing (DAMP bit = "0", POP bit = "0", AEN1 bit = "0" → "1", AEN0 bit = "0")"

"Line amplifier power-up timing (DAMP bit "0", POP bit "1", AEN1 bit "0" → "1", AEN0 bit = "0" → "1")"

"Line amplifier power-up timing (DAMP bit "0", POP bit "0", AEN1 bit "0" → "1", AEN0 bit = "0" → "1")"

"Speaker amplifier power-down timing (DAMP bit "0", AEN1 bit "0", AEN0 bit "1" → "0")"

"Line amplifier power-down timing (DAMP bit = "0", POP bit = "1", AEN1 bit = "1" → "0", AEN0 bit = "0")"

"Line amplifier power-down timing (DAMP bit = "0", POP bit = "0", AEN1 bit = "1" → "0", AEN0 bit = "0")"

"Line amplifier power-down timing (DAMP bit = "0", POP bit = "1", AEN1 bit = "1" → "0", AEN0 bit = "1" → "0")"

"Line amplifier power-down timing (DAMP bit = "0", POP bit = "0", AEN1 bit = "1" → "0, AEN0 bit = "1" → "0")"

## ◆ AVOL command

|           |   |   |     |     |     |     |   |   |          |
|-----------|---|---|-----|-----|-----|-----|---|---|----------|
| • Command | 0 | 0 | 0   | 0   | 1   | 0   | 0 | 0 | 1st byte |
|           | 0 | 0 | AV5 | AV4 | AV3 | AV2 | 0 | 0 | 2nd byte |

The AVOL command sets the volume of the speaker amplifier. This command can be input regardless of the NCR signal status.

The initial value after reset release is set to -4.0dB. Also, the setting values of the AVOL command are retained when the STOP command is inputted, but they are initialized when the power is down.

| AV5-AV2 | Description            | AV5-AV2 | Description |
|---------|------------------------|---------|-------------|
| F       | +12.0dB                | 7       | -8.0dB      |
| E       | +10.0dB                | 6       | -12.0dB     |
| D       | +8.0dB                 | 5       | -18.0dB     |
| C       | +6.0dB                 | 4       | -26.0dB     |
| B       | +4.0dB                 | 3       | -34.0dB     |
| A       | +2.0dB                 | 2       | Prohibited  |
| 9       | +0.0dB                 | 1       | Prohibited  |
| 8       | -4.0dB (initial value) | 0       | OFF         |

For timing of the AVOL command, refer to the "Change volume timing by AVOL command" in the timing chart.



## ◆ FADE command

|           |   |   |   |   |       |       |       |      |          |
|-----------|---|---|---|---|-------|-------|-------|------|----------|
| • Command | 0 | 0 | 0 | 0 | 1     | 1     | 0     | 0    | 1st byte |
|           | 0 | 0 | 0 | 0 | FCON2 | FCON1 | FCON0 | FADE | 2nd byte |

The FADE command sets the Fade function. This command can be input regardless of the NCR signal status. By using the fade function, the volume changes stepwise when the volume is changed by the CVOL command or the PAN command.

| FADE | Description                            |
|------|--|
| 0    | Fade function disabled (initial value) |
| 1    | Fade function enabled                  |

FCON2 to FCON0 set the volume that changes at every unit-time (sampling group period <sup>\*1</sup>) when the volume is changed to the volume set by the CVOL command or the PAN command.

| FCON2 | FCON1 | FCON0 | Description                             |
|-------|-------|-------|---|
| 0     | 0     | 0     | Volume change in 0 dB × 128/32768 steps |
| 0     | 0     | 1     | Volume change in 0 dB × 64/32768 steps  |
| 0     | 1     | 0     | Volume change in 0 dB × 32/32768 steps  |
| 0     | 1     | 1     | Volume change in 0 dB × 16/32768 steps  |
| 1     | 0     | 0     | Volume change in 0 dB × 8/32768 steps   |
| 1     | 0     | 1     | Volume change in 0 dB × 4/32768 steps   |
| 1     | 1     | 0     | Volume change in 0 dB × 2/32768 steps   |
| 1     | 1     | 1     | Volume change in 0 dB × 1/32768 steps   |

The smaller the voltage step that changes for each sampling frequency group, the less the pop noise, but the longer the transition time until the set volume is reached. The transition time is expressed by the following equation.

Volume-transition time for CVOL command

$$= \frac{[Current\ CVOL\ setting] - [New\ CVOL\ setting]}{[Sampling-frequency\ group\ *1]} \times \{264 \div (256 \div 2^{[FCON2-FCON0\ setting]})\}^{*2}$$

\*1 Sampling frequency group

|                          |         |
|--------------------------|---------|
| At 10.7/21.3kHz:         | 23.44μs |
| At 6.4/12.8/25.6kHz:     | 39.06μs |
| At 8.0/16.0/32.0kHz:     | 31.25μs |
| At 11.025/22.05/44.1kHz: | 22.68μs |
| At 12.0/24.0/48.0kHz:    | 20.83μs |

\*2 Rounding up after the decimal point

For the timing of the FADE command, refer to the "FADE command timing" in the timing chart.

## ◆ FDIRECT command

|           |      |      |      |      |      |      |      |      |          |
|-----------|------|------|------|------|------|------|------|------|----------|
| • Command | 0    | 0    | 0    | 1    | 0    | 0    | 0    | 0    | 1st byte |
|           | PRT7 | PRT6 | PRT5 | PRT4 | PRT3 | PRT2 | PRT1 | PRT0 | 2nd byte |

The FDIRECT command controls accesses to the flash memory using the clock synchronous serial interface. Input the command after inputting the PUP command.

If the protection code of the flash memory area is not 0x69 and the protection codes (PRT7 to PRT0) entered in the second byte match the protection code set when creating sound data, the flash memory access mode is entered. After that, the flash memory can be accessed using the clock synchronous serial interface.

If the protection code set when creating sound data is 0x69, the flash memory does not change to flash memory access mode even if the code matches.

To cancel the flash memory access mode, insert a reset (RESETB = "L") and conduct initialization or turn off the power supply.

Do not enter this command because this command is ignored when this command is entered from the I<sup>2</sup>C interface.

For the protection codes of the flash memory area, refer to the "Speech LSI Utility Setting Items".

For the timing of the FDIRECT command, refer to the "FDIRECT command timing" in the timing chart.

## ◆ WDTCL command

- Command 

|   |   |   |   |   |   |   |   |
|---|---|---|---|---|---|---|---|
| 0 | 0 | 0 | 1 | 0 | 1 | 0 | 0 |
|---|---|---|---|---|---|---|---|

The WDTCL command clears the watchdog timer counter (WDT counter). This command can be input regardless of the NCR signal status.

For information about the operation of the watchdog timer, refer to the "Misoperation detection and failure detection functions (Watchdog timer overflow detection)" in the "Function description".

For the timing of WDTCL command, refer to the "WDTCL command timing" in the timing chart.

## ◆ PDWN command

• Command 

|   |   |   |   |   |   |   |   |
|---|---|---|---|---|---|---|---|
| 0 | 0 | 1 | 0 | 0 | 0 | 0 | 0 |
|---|---|---|---|---|---|---|---|

The PDWN command is used to shift from the command standby state to the power-down state. The various settings are initialized, so the initial settings are required after power-up. It is invalid when the BUSYB signals of any channels are "L".

After inputting the PDWN command, oscillation stops following the elapse of the command processing time ( $t_{PD}$ ).

The states of the analog output pins during power-down are shown below.

| Analog output pin | Condition |
|-------------------|-----------|
| $V_{DDL}$         | DGND      |
| $V_{DDR}$         | DGND      |
| SG                | DGND      |
| SPM               | HiZ       |
| SPP               | SPGND     |
| LOUT              | DGND      |

For the power-down timing by PDWN command, refer to the "Power-Down timing" in the timing chart.

## ◆ FADR command

|           |    |    |    |    |    |    |    |    |          |
|-----------|----|----|----|----|----|----|----|----|----------|
| • Command | 0  | 0  | 1  | 1  | F9 | F8 | C1 | C0 | 1st byte |
|           | F7 | F6 | F5 | F4 | F3 | F2 | F1 | F0 | 2nd byte |

The FADR command sets the channels and phrases to be played. This command can be input when the NCR signal of the corresponding channel is "H" level.

Playback is started by the START command after the playback phrases of each channel are specified.

The phrases (F9-F0) to be played back are specified when creating sound data. Set the phrase specified when creating.

This command can only set up to 0 to 1023 phrases. To specify 1024 phrases or more, use FADR2 command.

The channel settings are as follows:

| C1 | C0 | Description |
|----|----|-------------|
| 0  | 0  | Channel 0   |
| 0  | 1  | Channel 1   |
| 1  | 0  | Channel 2   |
| 1  | 1  | Channel 3   |

For the timing of the FADR command, refer to the "Setting playback phrases using FADR command" in the timing chart.

## ◆ PLAY command

|           |    |    |    |    |    |    |    |    |          |
|-----------|----|----|----|----|----|----|----|----|----------|
| • Command | 0  | 1  | 0  | 0  | F9 | F8 | C1 | C0 | 1st byte |
|           | F7 | F6 | F5 | F4 | F3 | F2 | F1 | F0 | 2nd byte |

The PLAY command is played by specifying channels and phrases. This command can be input when the NCR signal of the corresponding channel is "H" level.

The phrases (F9-F0) to be played back are specified when creating sound data. Set the phrase specified when creating. This command can only set up to 0 to 1023 phrases. To specify 1024 phrases or more, use PLAY2 command.

The channel settings are as follows:

| C1 | C0 | Description |
|----|----|-------------|
| 0  | 0  | Channel 0   |
| 0  | 1  | Channel 1   |
| 1  | 0  | Channel 2   |
| 1  | 1  | Channel 3   |

For the playback start timing by the PLAY command, refer to the "Playback start timing by PLAY command" in the timing chart.

For the timing of continuous playback, refer to the "Continuous playback timing by PLAY command" in the timing chart.

## ◆ START command

• Command 

|   |   |   |   |     |     |     |     |
|---|---|---|---|-----|-----|-----|-----|
| 0 | 1 | 0 | 1 | CH3 | CH2 | CH1 | CH0 |
|---|---|---|---|-----|-----|-----|-----|

 1st byte

The START command starts playing back the specified channels. Specify the phrase to be played by the FADR command prior to entering the START command. Setting the CH0 to CH3 bit to 1 plays back the corresponding channel. This command can be input when the NCR signal of the corresponding channel is "H" level.

The channel settings are as follows:

| Channeled | Description  |
|-----------|--|
| CH0       | When this bit is set to 1, channel 0 is played back. |
| CH1       | When this bit is set to 1, channel 1 is played back. |
| CH2       | When this bit is set to 1, channel 2 is played back. |
| CH3       | When this bit is set to 1, channel 3 is played back. |

Be sure to specify one of the channels for the channel setting (CH0-CH3).

Do not input it to "0" (all "0") with specifying nothing. If it is input with specifying nothing (all "0"), the command is ignored.

For the playback start timing by the START command, refer to the "Playback start timing by START command" in the timing chart.

For the timing of continuous playback, refer to the "Continuous playback timing by START command" in the timing chart.

## ◆ STOP command

• Command 

|   |   |   |   |     |     |     |     |
|---|---|---|---|-----|-----|-----|-----|
| 0 | 1 | 1 | 0 | CH3 | CH2 | CH1 | CH0 |
|---|---|---|---|-----|-----|-----|-----|

 1st byte

The STOP command stops playing back the specified channel. Setting the CH0 to CH3 bit to "1" stops playback of the corresponding channel. When the corresponding channel stops playing back, the NCR and BUSYB signals become "H".

The STOP command can be input regardless of the status of the NCR during playback operation. However, following the elapse of CBUSYB "L" level output time 3 (tCB3), input the next command after confirming that the BUSYB signal becomes "H".

If the BUSYB signal does not become "H", enter the STOP command again.

Refer to the "Playback stop flow" in the command flowchart for more information.

The channel settings are as follows:

| Channeled | Description                            |
|-----------|--|
| CH0       | Setting this bit to 1 stops channel 0. |
| CH1       | Setting this bit to 1 stops channel 1. |
| CH2       | Setting this bit to 1 stops channel 2. |
| CH3       | Setting this bit to 1 stops channel 3. |

Be sure to specify one of the channels for the channel setting (CH0-CH3).

Do not input it to "0" (all "0") with specifying nothing. If it is input with specifying nothing (all "0"), the command is ignored.

For the timing of the STOP command, refer to the "STOP command (when the FAD bit is "L")" and "STOP command (when the FAD bit is "H")" in the timing chart.



◆ MUON command

|           |    |    |    |    |     |     |     |     |          |
|-----------|----|----|----|----|-----|-----|-----|-----|----------|
| • Command | 0  | 1  | 1  | 1  | CH3 | CH2 | CH1 | CH0 | 1st byte |
|           | M7 | M6 | M5 | M4 | M3  | M2  | M1  | M0  | 2nd byte |

The MUON command inserts silence between two phrases to be played. This command can be inputted when the NCR signal of the corresponding channel is "H" level.

Repeated playing back (the SLOOP command) of the MUON command is not possible.

The silence duration ( $t_{\text{mu}}$ ) is specified by the M7-M0 bits and can be set from 20ms to 1,024ms in 252 steps at 4ms intervals. The equation for setting the silence duration ( $t_{\text{mu}}$ ) is as follows.

However, set the silence setting (M7-M0) to 04h or more ( $t_{\text{mu}} \geq 20\text{ms}$ ).

$$t_{\text{mu}} = (2^7 \times (M7) + 2^6 \times (M6) + 2^5 \times (M5) + 2^4 \times (M4) + 2^3 \times (M3) + 2^2 \times (M2) + 2^1 \times (M1) + 2^0 \times (M0) + 1) \times 4\text{ms}$$

The channel settings are as follows:

| Channeled | Description   |
|-----------|---|
| CH0       | Setting this bit to 1 inserts silence into channel 0. |
| CH1       | Setting this bit to 1 inserts silence into channel 1. |
| CH2       | Setting this bit to 1 inserts silence into channel 2. |
| CH3       | Setting this bit to 1 inserts silence into channel 3. |

Be sure to specify one of the channels for the channel setting (CH0-CH3).

Do not input it to "0" (all "0") with specifying nothing. If it is input with specifying nothing (all "0"), the command is ignored.

For the timing of the MUON command, refer to the "Playback start timing by MUON command" in the timing chart.

For the timing of continuous playback, refer to the "Continuous playback timing by MUON command" in the timing chart.

## ◆ SLOOP command

• Command 

|   |   |   |   |     |     |     |     |
|---|---|---|---|-----|-----|-----|-----|
| 1 | 0 | 0 | 0 | CH3 | CH2 | CH1 | CH0 |
|---|---|---|---|-----|-----|-----|-----|

 1st byte

The SLOOP command sets the repeat playback of the specified channel. Setting the CH0 to CH3 bit to 1 repeatedly plays back the corresponding channel. This command can be input when the NCR signal of the corresponding channel is "H" level.

When repeat playback is set, playback is repeatedly performed until the repeat playback setting is canceled by the CLOOP command or playback is stopped by the STOP command. Also, if the phrase has been edited, the edited phrase is played repeatedly.

The channel settings are as follows:

| Channeled | Description  |
|-----------|--|
| CH0       | Setting this bit to 1 repeats playback on channel 0. |
| CH1       | Setting this bit to 1 repeats playback on channel 1. |
| CH2       | Setting this bit to 1 repeats playback on channel 2. |
| CH3       | Setting this bit to 1 repeats playback on channel 3. |

Be sure to specify one of the channels for the channel setting (CH0-CH3).

Do not input it to "0" (all "0") with specifying nothing. If it is input with specifying nothing (all "0"), the command is ignored.

For the timing of the SLOOP command, refer to the "Repeat playback setting/release timing by SLOOP/CLOOP command" in the timing chart.

## ◆ CLOOP command

• Command 

|   |   |   |   |     |     |     |     |
|---|---|---|---|-----|-----|-----|-----|
| 1 | 0 | 0 | 1 | CH3 | CH2 | CH1 | CH0 |
|---|---|---|---|-----|-----|-----|-----|

 1st byte

The CLOOP command releases repeat playback of the specified channel. This command can be input regardless of the NCR signal status.

Setting the CH0 to CH3 bit to "1" cancels repeat playback of the corresponding channel. When repeat playback is released, the NCR signal becomes "H" level.

The channel settings are as follows:

| Channeled | Description   |
|-----------|---|
| CH0       | Setting this bit to 1 cancels repeat playback on channel 0. |
| CH1       | Setting this bit to 1 cancels repeat playback on channel 1. |
| CH2       | Setting this bit to 1 cancels repeat playback on channel 2. |
| CH3       | Setting this bit to 1 cancels repeat playback on channel 3. |

Be sure to specify one of the channels for the channel setting (CH0-CH3).

Do not input it to "0" (all "0") with specifying nothing. If it is input with specifying nothing (all "0"), the command is ignored.

For the timing of the CLOOP command, refer to the "Repeat playback setting/release timing by SLOOP/CLOOP command" in the timing chart.

## ◆ CVOL command

|           |   |     |     |     |     |     |     |     |          |
|-----------|---|-----|-----|-----|-----|-----|-----|-----|----------|
| • Command | 1 | 0   | 1   | 0   | CH3 | CH2 | CH1 | CH0 | 1st byte |
|           | 0 | CV1 | CV0 | CV6 | CV5 | CV4 | CV3 | CV2 | 2nd byte |

The CVOL command sets the playback volume of the specified channel. This command can be input regardless of the NCR signal status.

Setting the CH0 to CH3 bit to 1 sets the volume of the corresponding channel.

The volume can be set at 128 levels.

The setting values are initialized when a reset is inserted (RESETB = "L") and PDWN command is input.

The CV1 and CV0 of the second bytes of the CVOL command are located at the top of the CV6 to CV2.

| CV1, CV0,<br>CV6-CV2 | Description               | CV1, CV0,<br>CV6-CV2 | Description | CV1, CV0,<br>CV6-CV2 | Description | CV1, CV0,<br>CV6-CV2 | Description |
|----------------------|---------------------------|----------------------|-------------|----------------------|-------------|----------------------|-------------|
| 00                   | 0.00dB<br>(initial value) | 08                   | -2.59dB     | 10                   | -6.31dB     | 18                   | -12.93dB    |
| 20                   | -0.07dB                   | 28                   | -2.69dB     | 30                   | -6.45dB     | 38                   | -13.24dB    |
| 40                   | -0.14dB                   | 48                   | -2.78dB     | 50                   | -6.60dB     | 58                   | -13.57dB    |
| 60                   | -0.21dB                   | 68                   | -2.88dB     | 70                   | -6.75dB     | 78                   | -13.91dB    |
| 01                   | -0.28dB                   | 09                   | -2.98dB     | 11                   | -6.90dB     | 19                   | -14.26dB    |
| 21                   | -0.36dB                   | 29                   | -3.08dB     | 31                   | -7.06dB     | 39                   | -14.63dB    |
| 41                   | -0.43dB                   | 49                   | -3.18dB     | 51                   | -7.22dB     | 59                   | -15.02dB    |
| 61                   | -0.50dB                   | 69                   | -3.28dB     | 71                   | -7.38dB     | 79                   | -15.42dB    |
| 02                   | -0.58dB                   | 0A                   | -3.38dB     | 12                   | -7.55dB     | 1A                   | -15.85dB    |
| 22                   | -0.65dB                   | 2A                   | -3.49dB     | 32                   | -7.72dB     | 3A                   | -16.29dB    |
| 42                   | -0.73dB                   | 4A                   | -3.59dB     | 52                   | -7.89dB     | 5A                   | -16.76dB    |
| 62                   | -0.81dB                   | 6A                   | -3.70dB     | 72                   | -8.06dB     | 7A                   | -17.26dB    |
| 03                   | -0.88dB                   | 0B                   | -3.81dB     | 13                   | -8.24dB     | 1B                   | -17.79dB    |
| 23                   | -0.96dB                   | 2B                   | -3.92dB     | 33                   | -8.43dB     | 3B                   | -18.35dB    |
| 43                   | -1.04dB                   | 4B                   | -4.03dB     | 53                   | -8.61dB     | 5B                   | -18.95dB    |
| 63                   | -1.12dB                   | 6B                   | -4.14dB     | 73                   | -8.80dB     | 7B                   | -19.59dB    |
| 04                   | -1.20dB                   | 0C                   | -4.25dB     | 14                   | -9.00dB     | 1C                   | -20.28dB    |
| 24                   | -1.28dB                   | 2C                   | -4.37dB     | 34                   | -9.20dB     | 3C                   | -21.04dB    |
| 44                   | -1.36dB                   | 4C                   | -4.48dB     | 54                   | -9.40dB     | 5C                   | -21.87dB    |
| 64                   | -1.44dB                   | 6C                   | -4.60dB     | 74                   | -9.61dB     | 7C                   | -22.78dB    |
| 05                   | -1.53dB                   | 0D                   | -4.72dB     | 15                   | -9.83dB     | 1D                   | -23.81dB    |
| 25                   | -1.61dB                   | 2D                   | -4.84dB     | 35                   | -10.05dB    | 3D                   | -24.97dB    |
| 45                   | -1.70dB                   | 4D                   | -4.97dB     | 55                   | -10.27dB    | 5D                   | -26.31dB    |
| 65                   | -1.78dB                   | 6D                   | -5.09dB     | 75                   | -10.50dB    | 7D                   | -27.89dB    |
| 06                   | -1.87dB                   | 0E                   | -5.22dB     | 16                   | -10.74dB    | 1E                   | -29.83dB    |
| 26                   | -1.96dB                   | 2E                   | -5.35dB     | 36                   | -10.99dB    | 3E                   | -32.33dB    |
| 46                   | -2.04dB                   | 4E                   | -5.48dB     | 56                   | -11.24dB    | 5E                   | -35.85dB    |
| 66                   | -2.13dB                   | 6E                   | -5.61dB     | 76                   | -11.50dB    | 7E                   | -41.87dB    |
| 07                   | -2.22dB                   | 0F                   | -5.74dB     | 17                   | -11.77dB    | 1F                   | -44.37dB    |
| 27                   | -2.31dB                   | 2F                   | -5.88dB     | 37                   | -12.04dB    | 3F                   | -47.89dB    |
| 47                   | -2.41dB                   | 4F                   | -6.02dB     | 57                   | -12.33dB    | 5F                   | -53.91dB    |
| 67                   | -2.50dB                   | 6F                   | -6.16dB     | 77                   | -12.62dB    | 7F                   | OFF         |

The volume can also be set at 32 levels by fixing the CV1 and CV0 bits to "0".

| CV6-CV2 | Description            | CV6-CV2 | Description |
|---------|------------------------|---------|-------------|
| 00      | 0.00dB (initial value) | 10      | -6.31dB     |
| 01      | -0.28dB                | 11      | -6.90dB     |
| 02      | -0.58dB                | 12      | -7.55dB     |
| 03      | -0.88dB                | 13      | -8.24dB     |
| 04      | -1.20dB                | 14      | -9.00dB     |
| 05      | -1.53dB                | 15      | -9.83dB     |
| 06      | -1.87dB                | 16      | -10.74dB    |
| 07      | -2.22dB                | 17      | -11.77dB    |
| 08      | -2.59dB                | 18      | -12.93dB    |
| 09      | -2.98dB                | 19      | -14.26dB    |
| 0A      | -3.38dB                | 1A      | -15.85dB    |
| 0B      | -3.81dB                | 1B      | -17.79dB    |
| 0C      | -4.25dB                | 1C      | -20.28dB    |
| 0D      | -4.72dB                | 1D      | -23.81dB    |
| 0E      | -5.22dB                | 1E      | -29.83dB    |
| 0F      | -5.74dB                | 1F      | -44.37dB    |

The channel settings are as follows:

| Channeled | Description  |
|-----------|--|
| CH0       | Setting this bit to 1 set the volume of channel 0. |
| CH1       | Setting this bit to 1 set the volume of channel 1. |
| CH2       | Setting this bit to 1 set the volume of channel 2. |
| CH3       | Setting this bit to 1 set the volume of channel 3. |

Be sure to specify one of the channels for the channel setting (CH0-CH3). When multiple channels are specified, the volume of the specified channels is set.

Do not input it to "0" (all "0") with specifying nothing. If it is input with specifying nothing (all "0"), the command is ignored.

For timing of the CVOL command, refer to the "Change volume timing by CVOL command" in the timing chart.

◆ RDSTAT command

• Command 

|   |   |   |   |   |   |   |   |
|---|---|---|---|---|---|---|---|
| 1 | 0 | 1 | 1 | 0 | 0 | 0 | 0 |
|---|---|---|---|---|---|---|---|

 1st byte

The RDSTAT command reads the internal operating states. This command can be input regardless of the NCR signal status. When reading the status of the second byte after command input, set the SI pin to "L".

The internal operating states read in the second byte are as follows:

|             |        |        |        |        |      |      |      |      |
|-------------|--------|--------|--------|--------|------|------|------|------|
| 2nd byte    | D7     | D6     | D5     | D4     | D3   | D2   | D1   | D0   |
| Output data | BUSYB3 | BUSYB2 | BUSYB1 | BUSYB0 | NCR3 | NCR2 | NCR1 | NCR0 |

The NCR signal outputs "L" during command processing and playback standby, and outputs "H" in other states. The BUSYB signal outputs "L" during command processing and playback sound, and outputs "H" in other states.

| D7 to D0 | Description                |
|----------|----------------------------|
| BUSYB3   | BUSYB outputs of channel 3 |
| BUSYB2   | BUSYB outputs of channel 2 |
| BUSYB1   | BUSYB outputs of channel 1 |
| BUSYB0   | BUSYB outputs of channel 0 |
| NCR3     | NCR output of channel 3    |
| NCR2     | NCR output of channel 2    |
| NCR1     | NCR output of channel 1    |
| NCR0     | NCR output of channel 0    |

For the timing of the RDSTAT command, refer to the "RDSTAT command timing" in the timing chart.

## ◆ RDVER command

• Command 

|   |   |   |   |   |   |   |   |
|---|---|---|---|---|---|---|---|
| 1 | 0 | 1 | 1 | 0 | 1 | 0 | 0 |
|---|---|---|---|---|---|---|---|

 1st byte

The RDVER command reads the sound ROM information. This command can be input regardless of the NCR signal status. When reading the sound ROM information in the second byte after command input, set the SI pin to "L".

The sound ROM information read in the second byte is as follows:

|             |      |      |      |      |      |      |      |      |
|-------------|------|------|------|------|------|------|------|------|
| 2nd byte    | D7   | D6   | D5   | D4   | D3   | D2   | D1   | D0   |
| Output data | VER7 | VER6 | VER5 | VER4 | VER3 | VER2 | VER1 | VER0 |

Sound ROM information can be set by using dedicated tool (Speech LSI Utility) when creating sound data.

For the timing of the RDVER command, refer to the "RDVER command timing" in the timing chart.

## ◆ RDERR command

• Command 

|   |   |   |   |   |   |   |       |
|---|---|---|---|---|---|---|-------|
| 1 | 0 | 1 | 1 | 1 | 0 | 0 | ERSEL |
|---|---|---|---|---|---|---|-------|

 1st byte

The RDERR command read misoperation detection and failure detection status. This command can be input regardless of the NCR signal status. When reading error information in the second byte after command input, set the SI pin to "L".

If the outputs of misoperation detection and failure detection are selected by OUTSTAT command, and the read data is all "L" even though STATUS1 or STATUS2 pin is "H", the read data cannot be read normally. Be sure to read it again.

The data to be read differs depending on the ERSEL bit. When an error occurs, use this command to check the error information corresponding to various misoperation detection and failure detection status set by the SAFE command.

The error information read in the second byte when ERSEL = "0" is as follows.

|             |        |        |        |        |        |        |        |        |
|-------------|--------|--------|--------|--------|--------|--------|--------|--------|
| 2nd byte    | D7     | D6     | D5     | D4     | D3     | D2     | D1     | D0     |
| Output data | OSCERR | RSTERR | WDTERR | ROMERR | SPDERR | TSDERR | DCDERR | WCMERR |

The error information read in the second byte when ERSEL = "1" is as follows.

|             |        |         |         |        |    |    |    |          |
|-------------|--------|---------|---------|--------|----|----|----|----------|
| 2nd byte    | D7     | D6      | D5      | D4     | D3 | D2 | D1 | D0       |
| Output data | MIXERR | SAINERR | LRCKERR | BCKERR | 0  | 0  | 0  | WVDIFERR |

Misoperation detection and failure detection status are as follows.

| Error signal | Description   |
|--------------|---|
| WCMERR       | This bit is set to "1" when an error of the command is detected.  |
| DCDERR       | This bit is set to "1" when the disconnection of the speaker connected to the SPP and SPM pins is detected.   |
| TSDERR       | This bit is set to "1" when the LSI temperature becomes 130°C or higher.  |
| SPDERR       | This bit is set to "1" when the SPP pin and the SPM pin are short-circuited, or when the SPP pin or the SPM pin is short-circuited to GND.  |
| ROMERR       | This bit is set to 1 when an error is detected in the flash memory.   |
| WDTERR       | This bit is set to "1" when the first overflow of the watchdog timer counter occurs.  |
| RSTERR       | This bit is set to "1" when the second overflow of the watchdog timer counter occurs. Alternatively, this bit is set to "1" when the RST counter, which starts operation by any of the error detections, overflows. |
| OSCERR       | This bit is set to "1" when the clock input from the crystal resonator or ceramic resonator is stopped.   |
| WVDIFERR     | This bit is set to "1" when the Wave Difference Error of playback sound error detection function is detected.   |
| BCKERR       | This bit is set to "1" when the disconnection/short circuit of the BCLK is detected.  |
| LRCKERR      | This bit is set to "1" when the disconnection/short circuit of the LRCLK is detected.   |
| SAINERR      | This bit is set to "1" when the disconnection or short circuit of SAI_IN is detected.   |
| MIXERR       | This bit is set to "1" when an error in the mixing number is detected.  |

For details on misoperation detection and failure detection, refer to the "Misoperation detection and failure detection functions" in the "Function description".

For the timing of the RDERR command, refer to the "RDERR command timing" in the timing chart.



◆ OUTSTAT command

|           |   |      |      |      |     |     |     |     |   |          |
|-----------|---|------|------|------|-----|-----|-----|-----|---|----------|
| • Command | 1 | 1    | 0    | 0    | 0   | 0   | 0   | 0   | 0 | 1st byte |
|           | 0 | PORT | STA1 | STA0 | CH3 | CH2 | CH1 | CH0 |   | 2nd byte |

The OUTSTAT command selects the internal operating states output to the STATUS1 pin and STATUS2 pin. This command can be input regardless of the NCR signal status.

| PORT | Description         |
|------|---------------------|
| 0    | STATUS1 Pin setting |
| 1    | STATUS2 Pin setting |

If the STATUS2 pin is set after the STATUS1 pin is set, the STATUS1 pin setting is retained. In the initial setting, the NCR of channel 0 is selected for the STATUS1 pin, and the BUSYB of channel 0 is selected for the STATUS2 pin.

| STA1 | STA0 | Description                                  |
|------|------|--|
| 0    | 0    | BUSYB  |
| 0    | 1    | NCR  |
| 1    | 0    | Misoperation detection and failure detection |
| 1    | 1    |  |

| Channeled | Description                              |
|-----------|--|
| CH0       | Setting this bit to 1 selects channel 0. |
| CH1       | Setting this bit to 1 selects channel 1. |
| CH2       | Setting this bit to 1 selects channel 2. |
| CH3       | Setting this bit to 1 selects channel 3. |

Channel settings are enabled when BUSYB or NCR is specified in the STA1/STA0. Multiple channels can also be set.

The relations between the STATUS1 pin and the STA1/STA0/CH3/CH2/CH1/CH0 are shown below.

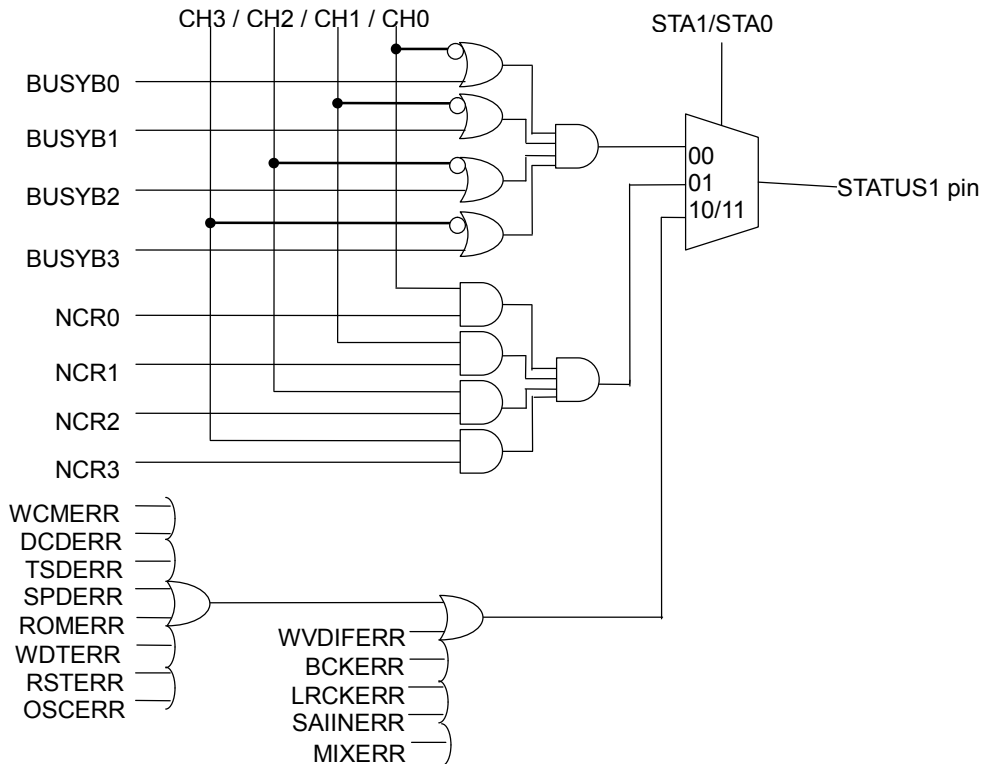

For the timing of the OUTSTAT command, refer to the "OUTSTAT command timing" in the timing chart.

◆ FADR2 command

|           |    |    |    |    |     |     |    |    |          |
|-----------|----|----|----|----|-----|-----|----|----|----------|
| • Command | 1  | 1  | 0  | 0  | 0   | 1   | 0  | 0  | 1st byte |
|           | 0  | 0  | C1 | C0 | F11 | F10 | F9 | F8 | 2nd byte |
|           | F7 | F6 | F5 | F4 | F3  | F2  | F1 | F0 | 3rd byte |

The FADR2 command sets the channels and phrases to be played. This command can be input when the NCR signal of the corresponding channel is "H" level.

Playback is started by the START command after the playback phrases of the channels are specified.

The phrases (F11-F0) to be played back are specified when creating sound data. Set the phrase specified when creating.

The channel settings are as follows:

| C1 | C0 | Description |
|----|----|-------------|
| 0  | 0  | Channel 0   |
| 0  | 1  | Channel 1   |
| 1  | 0  | Channel 2   |
| 1  | 1  | Channel 3   |

When the number of phrases to be played is 1024 or less, the channels and phrases can be specified by FADR command.

For the timing of the FADR2 command, refer to the "Setting timing of playback phrases by FADR2 command" in the timing chart.

## ◆ PLAY2 command

|           |    |    |    |    |     |     |    |    |          |
|-----------|----|----|----|----|-----|-----|----|----|----------|
| • Command | 1  | 1  | 0  | 0  | 1   | 0   | 0  | 0  | 1st byte |
|           | 0  | 0  | C1 | C0 | F11 | F10 | F9 | F8 | 2nd byte |
|           | F7 | F6 | F5 | F4 | F3  | F2  | F1 | F0 | 3rd byte |

The PLAY2 command is played by specifying channels and phrases. This command can be input when the NCR signal of the corresponding channel is "H" level.

The phrases (F11-F0) to be played back are specified when creating sound data. Set the phrase specified when creating.

The channel settings are as follows:

| C1 | C0 | Description |
|----|----|-------------|
| 0  | 0  | Channel 0   |
| 0  | 1  | Channel 1   |
| 1  | 0  | Channel 2   |
| 1  | 1  | Channel 3   |

When the number of phrases to be played is 1024 or less, the channels and phrases can be specified by PLAY command.

For the playback start timing by the PLAY2 command, refer to the "Playback start timing by PLAY2 command" in the timing chart.

◆ SAFE command

|                  |       |         |        |       |       |       |       |         |          |
|------------------|-------|---------|--------|-------|-------|-------|-------|---------|----------|
| • Command        | 1     | 1       | 0      | 1     | 0     | 0     | 0     | ERSEL   | 1st byte |
| When ERSEL = "0" | OSCEN | RSTEN   | WDTEN  | ROMEN | SPDEN | TSDEN | DCDEN | WCMEN   | 2nd byte |
| When ERSEL = "1" | MIXEN | SAIINEN | LRCKEN | BCKEN | 0     | 0     | 0     | WVDIFEN | 2nd byte |

The SAFE command is used to set the operation of the misoperation detection function and the failure detection function. The initial value is the operation stop state ("0"). When this bit is set to "1", operation starts.

Select the function to be set in the ERSEL. If ERSEL is set to "1" after setting ERSEL to "0", the function set with ERSEL = "0" is retained. The functions to be set when ERSEL = "0" are as follows.

| Error setting | Description  |
|---------------|--|
| WCMEN         | Set the command error detection.   |
| DCDEN         | Set the disconnection detection of the speakers connected to the SPP and SPM pins.                           |
| TSDEN         | Set the LSI temperature error detection.   |
| SPDEN         | Set the detection of short circuit between the SPP pin and the SPM pin.                                      |
| ROMEN         | Set error detection of flash memory.   |
| WDTEN*1       | Operate the watchdog timer and set overflow detection.   |
| RSTEN*1       | Operate the RST counter and set overflow detection, when any error is detected.                              |
| OSCEN         | Enable the error output for the stop detection of clock input from a crystal resonator or ceramic resonator. |

\*1 Do not set WDTEN and RSTEN to "1" at the same time. If these bits are set to "1" at the same time, only the RSTEN bit is set to "1".

The functions to be set when ERSEL = "1" are as follows.

| Error setting | Description   |
|---------------|---|
| WVDIFEN       | Set the Wave Difference Error detection of the playback sound error detection function. |
| BCKEN         | Set the BCLK disconnection/short detection.   |
| LRCKEN        | Set the LRCLK disconnection/short detection.  |
| SAIINEN       | Set the SAI_IN disconnection/short detection.   |
| MIXEN         | Set error detection of mixing number.   |

For details on misoperation detection and failure detection, refer to the "Misoperation detection and failure detection functions" in the function description.

For the timing of the SAFE command, refer to the "SAFE command timing" in the timing chart.

## ◆ ERRCL command

- Command 

|   |   |   |   |   |   |   |   |
|---|---|---|---|---|---|---|---|
| 1 | 1 | 1 | 1 | 1 | 1 | 1 | 1 |
|---|---|---|---|---|---|---|---|

The ERRCL command is a command that clears error bits that can be read by the RDERR command. The ERRCL command clears all error bits irrespective of the ERSEL bit of the RDERR command. This command can be input regardless of the NCR signal status.

However, if the error continues, the error bit remains in the error status even if the ERRCL command is entered.

For the timing of the ERRCL command, refer to the "ERRCL command timing" in the timing chart.

## ◆ PAN command

|         |    |    |    |    |    |    |    |    |          |
|---------|----|----|----|----|----|----|----|----|----------|
| Command | 1  | 1  | 1  | 1  | 0  | 0  | C1 | C0 | 1st byte |
|         | R3 | R2 | R1 | R0 | L3 | L2 | L1 | L0 | 2nd byte |

The PAN command sets the volume of the Lch/Rch during serial audio interface (SAI) operation. This command can be input regardless of the NCR signal status.

Set the volume during playback or before starting playback. The initial value is 0dB for both channels.

The Fade function can change the volume step by step.

The channel settings are as follows:

| C1 | C0 | Description |
|----|----|-------------|
| 0  | 0  | Channel 0   |
| 0  | 1  | Channel 1   |
| 1  | 0  | Channel 2   |
| 1  | 1  | Channel 3   |

The volume settings are as follows:

| R3/L3 | R2/L2 | R1/L1 | R0/L0 | Description          |
|-------|-------|-------|-------|----------------------|
| 0     | 0     | 0     | 0     | 0 dB (initial value) |
| 0     | 0     | 0     | 1     | -0.58dB              |
| 0     | 0     | 1     | 0     | -1.20dB              |
| 0     | 0     | 1     | 1     | -1.87dB              |
| 0     | 1     | 0     | 0     | -2.59dB              |
| 0     | 1     | 0     | 1     | -3.38dB              |
| 0     | 1     | 1     | 0     | -4.25dB              |
| 0     | 1     | 1     | 1     | -5.22dB              |
| 1     | 0     | 0     | 0     | -6.31dB              |
| 1     | 0     | 0     | 1     | -7.55dB              |
| 1     | 0     | 1     | 0     | -9.00dB              |
| 1     | 0     | 1     | 1     | -10.74dB             |
| 1     | 1     | 0     | 0     | -12.93dB             |
| 1     | 1     | 0     | 1     | -15.85dB             |
| 1     | 1     | 1     | 0     | -20.28dB             |
| 1     | 1     | 1     | 1     | OFF                  |

For the fade function, refer to the "FADE command".

For adjusting the Lch/Rch volume using FADE command, refer to the "Volume Settings" in the function description.

For the PAN command input timing, refer to the "Change volume timing by PAN command" in the timing chart.

## ◆ SAICH command

|         |   |     |     |     |   |     |     |     |          |
|---------|---|-----|-----|-----|---|-----|-----|-----|----------|
| Command | 1 | 1   | 1   | 0   | 0 | 0   | 0   | 1   | 1st byte |
|         | 0 | LC1 | LC0 | LEN | 0 | RC1 | RC0 | REN | 2nd byte |

The SAICH command sets the operation of the serial audio interface (SAI) and the channels on the Lch and Rch sides. Set these bits when channels other than SAIs are not playing back (BUSYBn is "1").

LEN and REN set the operation of the Lch side and the Rch side.

| LEN | Description   |
|-----|---|
| 0   | Stops the operation of the serial audio interface (SAI) on the Lch side (initial) |
| 1   | Starts the operation of the serial audio interface (SAI) on the Lch side.         |

| REN | Description   |
|-----|---|
| 0   | Stops the operation of the serial audio interface (SAI) on the Rch side (initial) |
| 1   | Starts the operation of the serial audio interface (SAI) on the Rch side.         |

LC1 to LC0 and RC1 to RC0 specify the playback channels of the Lch and Rch sides.

| RC1 | RC0 | Description                       |
|-----|-----|-----------------------------------|
| 0   | 0   | Specify Rch-side channel 0 (CH0). |
| 0   | 1   | Specify Rch-side channel 1 (CH1). |
| 1   | 0   | Specify Rch-side channel 2 (CH2). |
| 1   | 1   | Specify Rch-side channel 3 (CH3). |

| LC1 | LC0 | Description                       |
|-----|-----|-----------------------------------|
| 0   | 0   | Specify Lch-side channel 0 (CH0). |
| 0   | 1   | Specify Lch-side channel 1 (CH1). |
| 1   | 0   | Specify Lch-side channel 2 (CH2). |
| 1   | 1   | Specify Lch-side channel 3 (CH3). |

The LEN and REN bits cannot be set to "1" when the channels specified by LC1 to LC0 and RC1 to RC0 are playing back in a mode other than SAI (BUSYBn = "L").

If you want to set LEN="0" and REN="1" with LEN="1" and REN="0", set LEN="0" and REN="1" after setting LEN=REN="0".

When LEN and REN are set to "1" with the same channel specified by LC1 to LC0 and RC1 to RC0, only the Lch operates.

Start the LRCLK/BCLK input after entering the SAICON command.

Subsequently, enter the MUON command and then the SAICH command.

After entering the MUON command, enter the SAICH command at least 10ms prior to the end of the silence period set by the MUON command.

Use a channel that is not played back by SAICH as the playback channel set by MUON commands. To mix with ROM playback, use a channel for ROM playback. When ROM playback is started within the silence time set by the MUON commands, resulting in continuous playback, ROM playback is started after the set silence time elapses.

For the timing of inputting the SAICH command, refer to the "SAICH command timing" in the timing chart.

When LRCLK is faster by 5% or more, SAICH is initialized. For LRCLK failure detection, refer to the "Function description" section.

## ◆ SAICON command

|         |     |     |     |     |   |   |      |       |          |
|---------|-----|-----|-----|-----|---|---|------|-------|----------|
| Command | 1   | 1   | 1   | 0   | 0 | 0 | 1    | 0     | 1st byte |
|         | FS3 | FS2 | FS1 | FS0 | 0 | 1 | INEN | OUTEN | 2nd byte |

The SAICON command enable/disable input/output from the serial audio interface (SAI) pins.

Set this bit when the Lch-side serial audio interface (SAI) operation of the SAICH command is stopped (LEN="0") and the Rch-side serial audio interface (SAI) operation is stopped (REN="0"). If either LEN or REN is set to "1", the entered SAICON command is ignored.

| OUTEN | Description                              |
|-------|--|
| 0     | Stops SAI_OUT pin output (initial value) |
| 1     | Start SAI_OUT pin output                 |

| INEN | Description                              |
|------|--|
| 0    | Invalid SAI_IN pin input (initial value) |
| 1    | Valid SAI_IN pin input                   |

The FS3 to FS0 select the sampling frequency used for the serial audio interface (SAI).

| FS3 | FS2 | FS1 | FS0 | Description           |
|-----|-----|-----|-----|-----------------------|
| 0   | 0   | 0   | 0   | 8 kHz (initial value) |
| 0   | 0   | 0   | 1   | 16kHz                 |
| 0   | 0   | 1   | 0   | 32kHz                 |
| 0   | 0   | 1   | 1   | Setting prohibited    |
| 0   | 1   | 0   | 0   | 11.025kHz             |
| 0   | 1   | 0   | 1   | 22.05kHz              |
| 0   | 1   | 1   | 0   | 44.1kHz               |
| 0   | 1   | 1   | 1   | Setting prohibited    |
| 1   | 0   | 0   | 0   | 12kHz                 |
| 1   | 0   | 0   | 1   | 24kHz                 |
| 1   | 0   | 1   | 0   | 48kHz                 |
| 1   | 0   | 1   | 1   | Setting prohibited    |
| 1   | 1   | 0   | 0   | Setting prohibited    |
| 1   | 1   | 0   | 1   | Setting prohibited    |
| 1   | 1   | 1   | 0   | Setting prohibited    |
| 1   | 1   | 1   | 1   | Setting prohibited    |



The operating status for each setting of OUT\_EN and IN\_EN is as follows.

| IN_EN | OUT_EN | Playback sound |              |             |                                     | Playback operation   |
|-------|--------|----------------|--------------|-------------|-------------------------------------|--|
|       |        | Input          |              | Output      |                                     |  |
|       |        | SAI_IN pin     | Flash memory | SAI_OUT pin | Line amplifier or speaker amplifier |  |
| 0     | 0      | -              | ✓            | -           | ✓                                   | Playback from flash memory to line amplifier or speaker amplifier.   |
| 0     | 1      | -              | ✓            | ✓           | -                                   | Output from flash memory pin to SAI_OUT pin.*1   |
|       |        |                |              |             | ✓                                   | Playback from flash memory to line amplifier or speaker amplifier and SAI_OUT pin.                         |
| 1     | 0      | ✓              | -            | -           | ✓                                   | Playback from SAI_IN pin to line amplifier or speaker amplifier.   |
|       |        |                | ✓            |             |                                     | Playback the mixing of SAI_IN pin and flash memory to line amplifier or speaker amplifier.                 |
| 1     | 1      | ✓              | -            | ✓           | -                                   | Output from SAI_IN pin to SAI_OUT pin.*1   |
|       |        |                | ✓            |             |                                     | Output the mixing of SAI_IN pin and flash memory to SAI_OUT pin.*1   |
|       |        |                | -            |             | ✓                                   | Playback from SAI_IN pin to line amplifier or speaker amplifier and SAI_OUT pin.                           |
|       |        |                | ✓            |             |                                     | Playback the mixing of SAI_IN pin and flash memory to line amplifier or speaker amplifier and SAI_OUT pin. |

\*1: To output only to the SAI\_OUT pin, set DAG1,DAG0 bit of AMODE command to 0 (internal DAC signal input OFF).

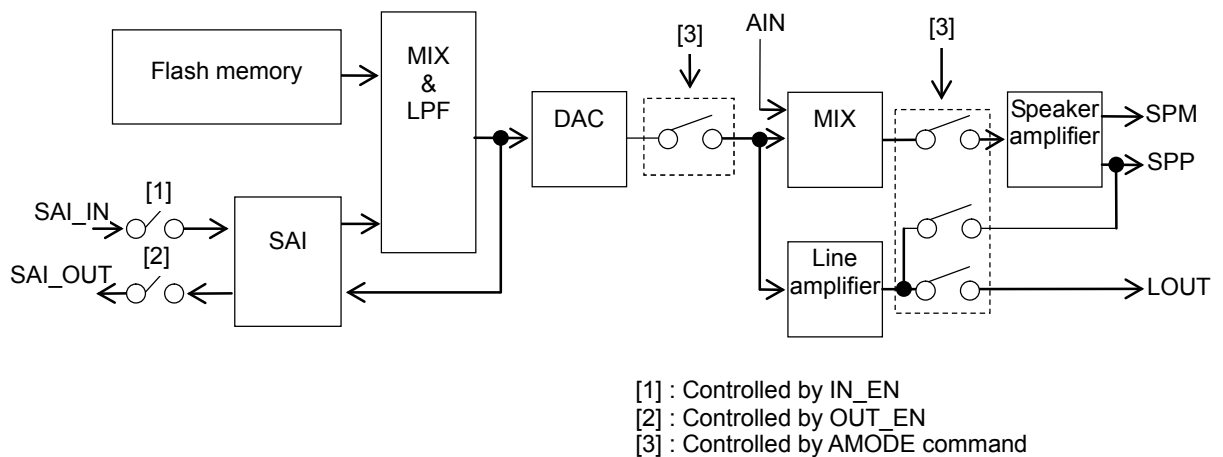

For the timing of inputting the SAICON command, refer to the "SAICON command timing" in the timing chart.

## ◆ SAITCON command

|         |     |   |   |      |        |   |      |      |          |
|---------|-----|---|---|------|--------|---|------|------|----------|
| Command | 1   | 1 | 1 | 0    | 0      | 0 | 1    | 1    | 1st byte |
|         | BWO | 0 | 0 | MSBO | ISSCKO | 0 | DLYO | WSLO | 2nd byte |

The SAITCON command sets the serial audio interface (SAI) transmission format.

Use the same format as that of SAIRCON command.

Set this bit when the Lch-side serial audio interface (SAI) operation of the SAICH command is stopped (LEN="0") and the Rch-side serial audio interface (SAI) operation is stopped (REN="0"). If either LEN or REN is set to "1", the entered SAITCON command is ignored.

WSLO specifies the LRCLK polarities when transmitting.

| WSLO | Description   |
|------|---|
| 0    | L channel is transmitted when LRCLK is "L" level,<br>R channel is transmitted when LRCLK is "H" level (initial value) |
| 1    | L channel is transmitted when LRCLK is "H" level,<br>R channel is transmitted when LRCLK is "L" level                 |

DLYO specifies whether transmit data has a 1-clock delay or not.

| DLYO | Description                       |
|------|-----------------------------------|
| 0    | Serial data delay (initial value) |
| 1    | No serial data delay              |

ISSCKO specifies the BCLK pin as 32fs or 64fs.

| ISSCKO | Description           |
|--------|-----------------------|
| 0      | 32 fs (initial value) |
| 1      | 64 fs                 |

MSBO specifies MSB first or LSB first in the transmit data.

| MSBO | Description               |
|------|---------------------------|
| 0    | MSB first (initial value) |
| 1    | LSB first                 |

BWO specifies the bit width for transmission.

| BWO | Description                         |
|-----|-------------------------------------|
| 0   | 16-bit straight PCM (initial value) |
| 1   | 8-bit straight PCM                  |

For the transmission format, refer to the "SAI (Serial Audio Interface)" in the function description.

For the timing of inputting the SAITCON command, refer to "SAITCON command timing" in the timing chart.

## ◆ SAIRCON command

|         |     |   |   |      |        |      |      |      |          |
|---------|-----|---|---|------|--------|------|------|------|----------|
| Command | 1   | 1 | 1 | 0    | 0      | 1    | 0    | 0    | 1st byte |
|         | BWI | 0 | 0 | MSBI | ISSCKI | AFOI | DLYI | WSLI | 2nd byte |

The SAIRCON command sets the serial audio interface (SAI) reception format.

Use the same format as that of SAITCON command.

Set this bit when the Lch-side serial audio interface (SAI) operation of the SAICH command is stopped (LEN="0") and the Rch-side serial audio interface (SAI) operation is stopped (REN="0"). If either LEN or REN is set to "1", the entered SAIRCON command is ignored.

WSLI specifies the LRCLK polarities for reception.

| WSLI | Description   |
|------|---|
| 0    | L channel is received when LRCLK is "L" level,<br>R channel is received when LRCLK is "H" level (initial value) |
| 1    | L channel is received when LRCLK is "H" level,<br>R channel is received when LRCLK is "L" level                 |

DLYI specifies whether the received data has a 1-clock delay or not.

| DLYI | Description                       |
|------|-----------------------------------|
| 0    | Serial data delay (initial value) |
| 1    | No serial data delay              |

AFOI specifies whether the received data is left-aligned or right-aligned.

| AFOI | Description                  |
|------|------------------------------|
| 0    | Left-justify (initial value) |
| 1    | Right-justify                |

ISSCKI specifies the BCLK pin as 32fs or 64fs.

| ISSCKI | Description           |
|--------|-----------------------|
| 0      | 32 fs (initial value) |
| 1      | 64 fs                 |

MSBI specifies MSB first or LSB first in the received data.

| MSBI | Description               |
|------|---------------------------|
| 0    | MSB first (initial value) |
| 1    | LSB first                 |

BWI specifies the bit width for reception.

| BWI | Description                         |
|-----|-------------------------------------|
| 0   | 16-bit straight PCM (initial value) |
| 1   | 8-bit straight PCM                  |

For the reception format, refer to the "SAI (Serial Audio Interface)" in the "Function description".

For the timing of inputting the SAIRCON command, refer to the "SAIRCON command timing" in the timing chart.

## ◆ SAIMOD command

|           |   |   |   |      |   |   |   |   |          |
|-----------|---|---|---|------|---|---|---|---|----------|
| • Command | 1 | 1 | 1 | 0    | 0 | 1 | 0 | 1 | 1st byte |
|           | 0 | 0 | 0 | BSWP | 0 | 0 | 0 | 0 | 2nd byte |

The SAIMOD command sets the mode of the serial audio interface (SAI).

Set this bit when the Lch-side serial audio interface (SAI) operation of the SAICH command is stopped (LEN="0") and the Rch-side serial audio interface (SAI) operation is stopped (REN="0"). If either LEN or REN is set to "1", the entered SAIMOD command is ignored.

BSWP sets byte-swapping of the order of the data to be transmitted and the data to be received.

| BSWP | Description   |
|------|---|
| 0    | No byte-swap (16-bit data order: 0bit-7 bit, 8bit-15 bit) (initial value) |
| 1    | With byte swap (16-bit data order: 8bit-15 bit, 0bit-7 bit)               |

For the timing of inputting the SAIMOD command, refer to the "SAIMOD command timing" in the timing chart.

## ◆ SCMODE command

|           |   |   |   |   |   |    |        |        |          |
|-----------|---|---|---|---|---|----|--------|--------|----------|
| • Command | 0 | 0 | 0 | 1 | 1 | RW | 0      | 0      | 1st byte |
|           | 0 | 0 | 0 | 0 | 0 | 0  | 0      | 0      | 2nd byte |
|           | 1 | 0 | 0 | 0 | 0 | 0  | AINDET | FBPATH | 3rd byte |

The SCMODE command sets the basic parameters for playback sound error detection.

| FBPATH | Description  |
|--------|--|
| 0      | The speaker output in the LSI is the target of playback sound error detection. (Initial value) |
| 1      | The FB1 and FB2 pin input is the target of playback sound error detection.                     |

| AINDET | Description  |
|--------|--|
| 0      | Playback sound error detection mode. (Initial value) |
| 1      | Disconnection of AIN detection mode.                 |

◆ WVDIFTH command

|           |               |               |               |               |               |               |               |               |          |
|-----------|---------------|---------------|---------------|---------------|---------------|---------------|---------------|---------------|----------|
| • Command | 0             | 0             | 0             | 1             | 1             | RW            | 0             | 0             | 1st byte |
|           | 0             | 0             | 0             | 1             | 1             | 1             | 1             | 0             | 2nd byte |
|           | WVDIFS<br>TH3 | WVDIFS<br>TH2 | WVDIFS<br>TH1 | WVDIFS<br>TH0 | WVDIFD<br>TH3 | WVDIFD<br>TH2 | WVDIFD<br>TH1 | WVDIFD<br>TH0 | 3rd byte |

The WVDIFTH command sets WAVE Difference Error thresholds. If the threshold value is exceeded, a WAVE Difference Error occurs.

Set the threshold value in the format of absolute value 18-bit data, which shifts the WVDIFDTH 4-bit data to the left by the WVDIFSTH setting value.

■ Command flowchart

- 1-byte command input flow(Applies to PUP, WDTCL, PDWN, START, STOP, SLOOP, CLOOP, and ERRCL commands.)

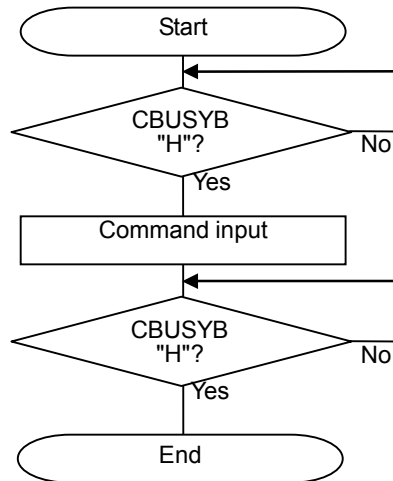

- 2-byte command input flow (Applies to AMODE, AVOL, FADE, FDIRECT, FADR, PLAY, MUON, CVOL, OUTSTAT, SAFE, PAN, and SAICH, SAICON, SAITCON, SAIRCON, SAIMOD commands.)

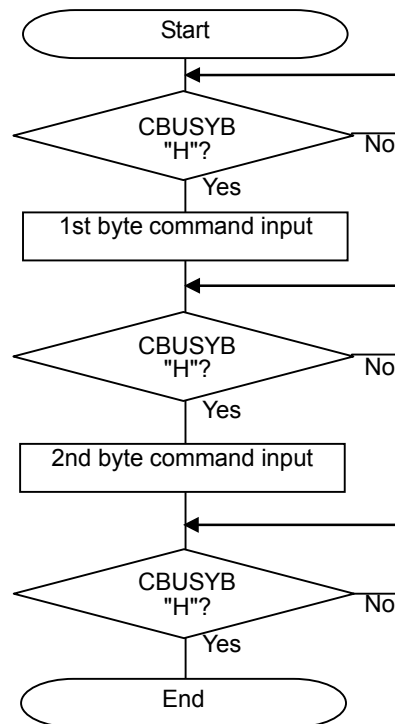



- 3-byte command input flow(Applies to FADR2, PLAY2 and playback sound error detection command group)

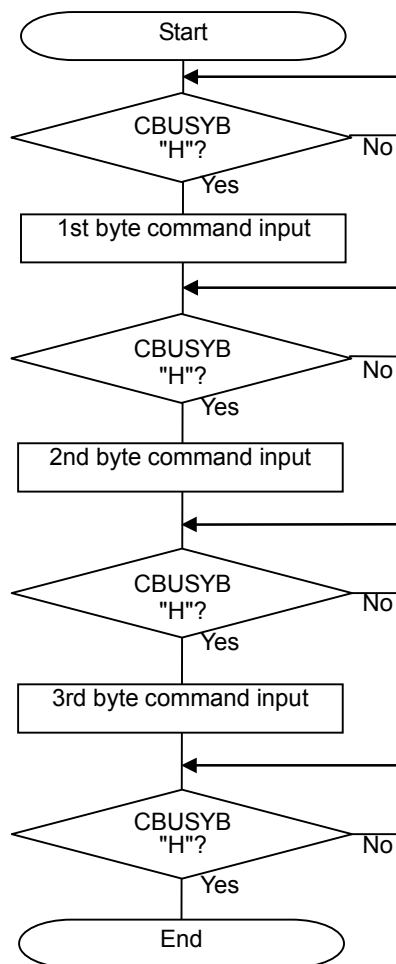

- Read flow (Applies to RDSTAT, RDVER, RDERR commands)

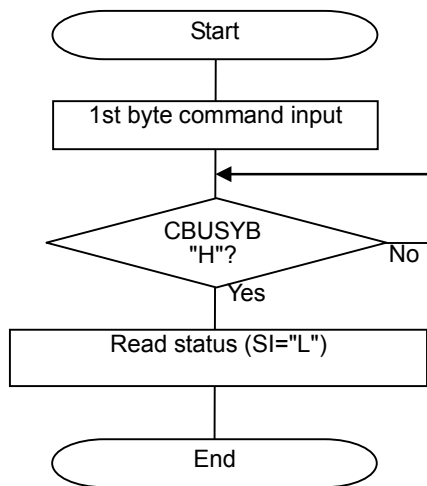

- Read flow (Applies to playback sound error detection command group)

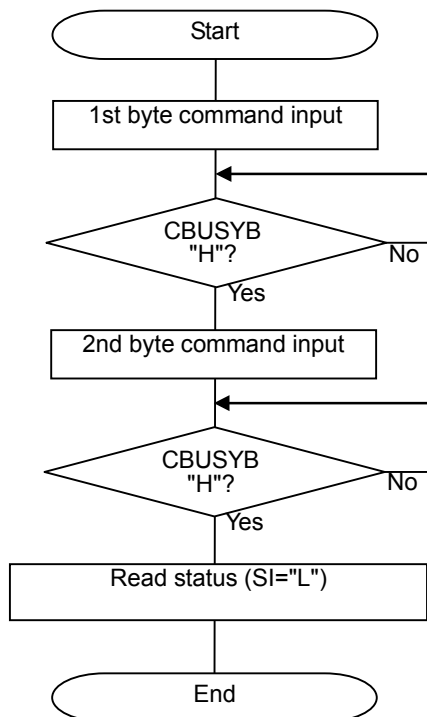

● Power-on flow

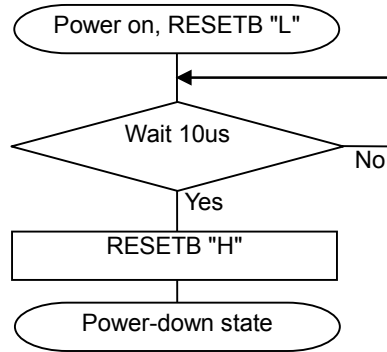

● MCU command interface flash memory access migration/cancel

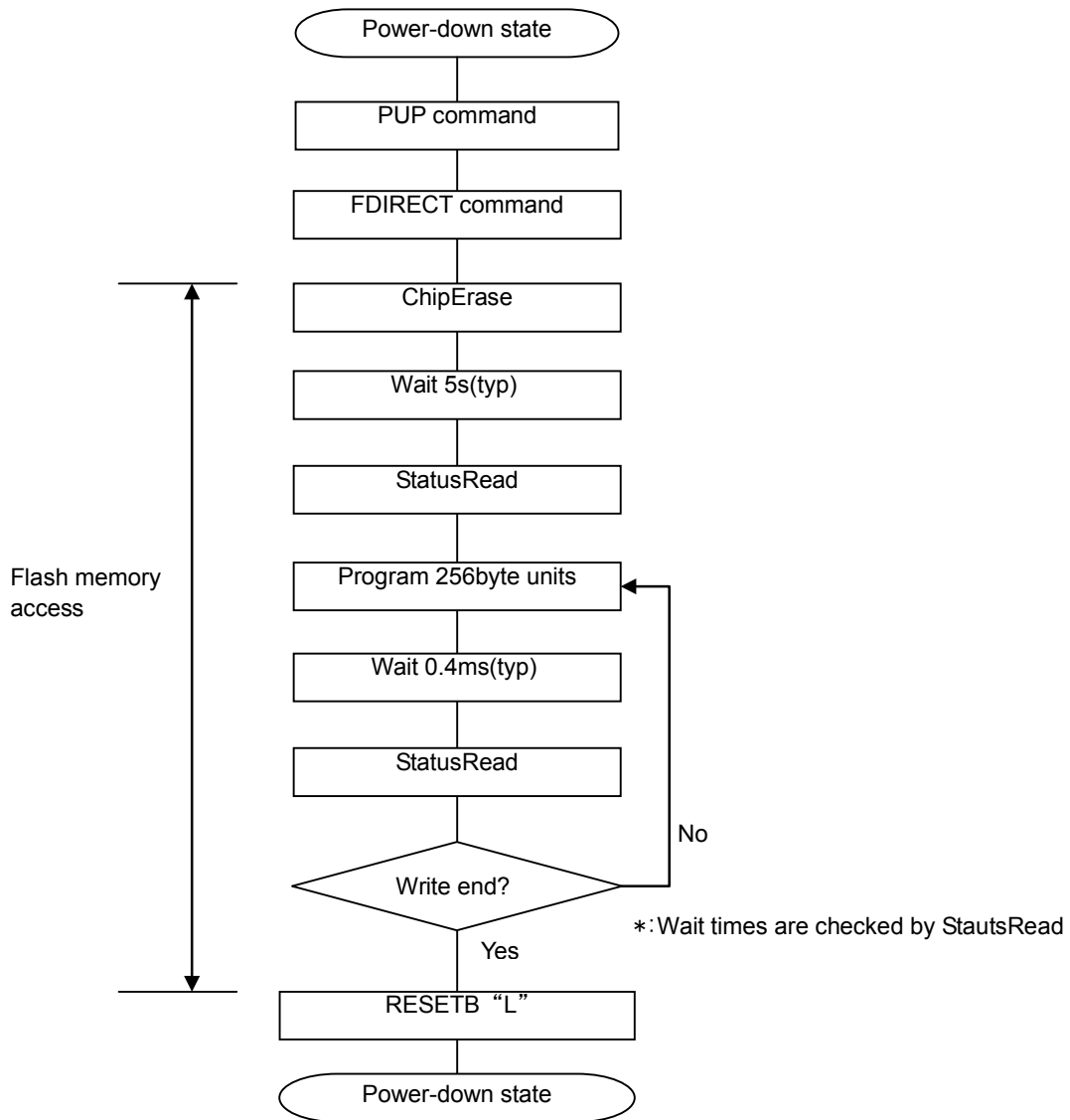

● Analog power-up flow

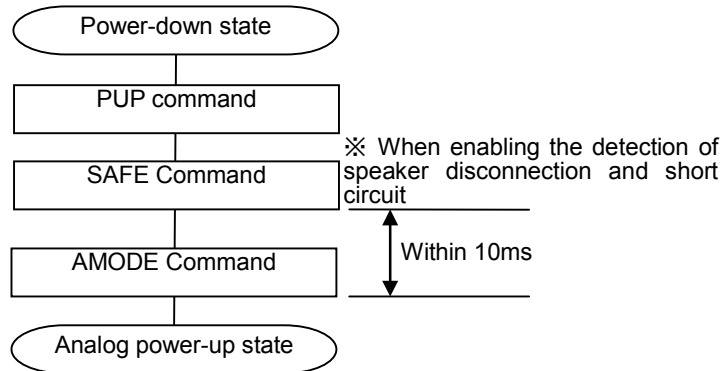

● Playback start flow

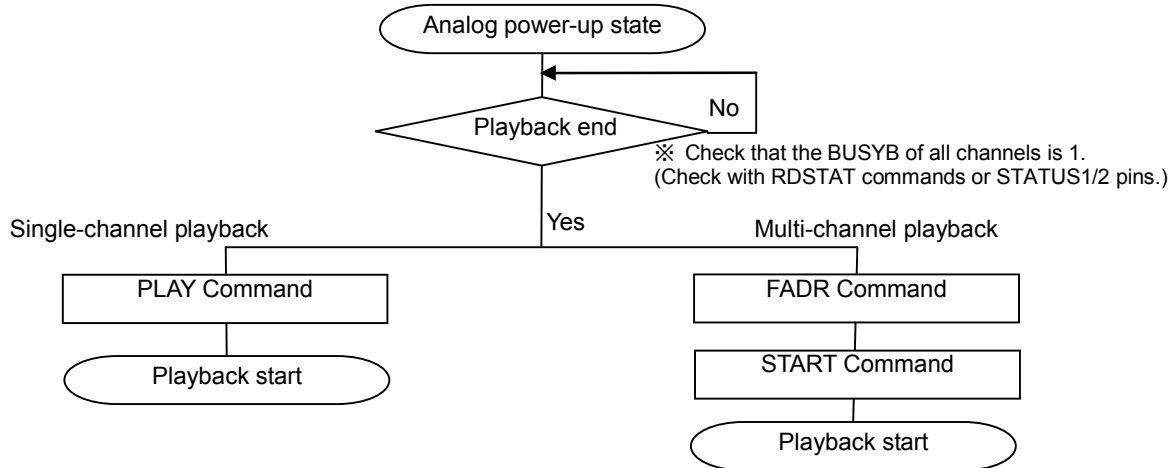

● Playback stop flow

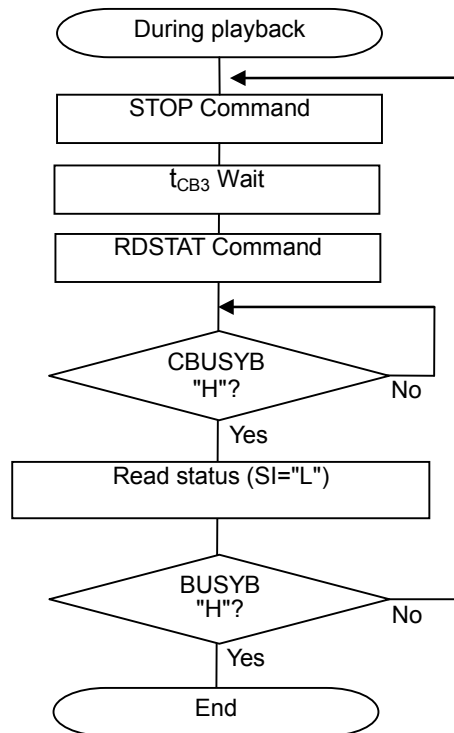

● Continuous playback flow

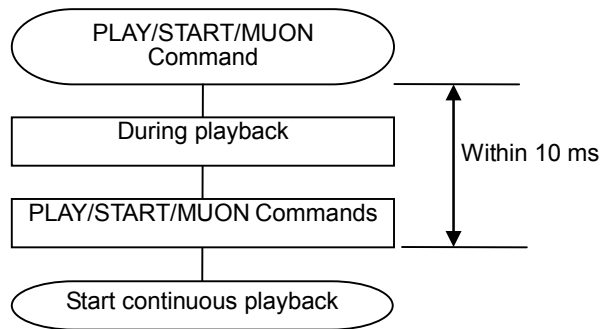

● Loop playback start flow

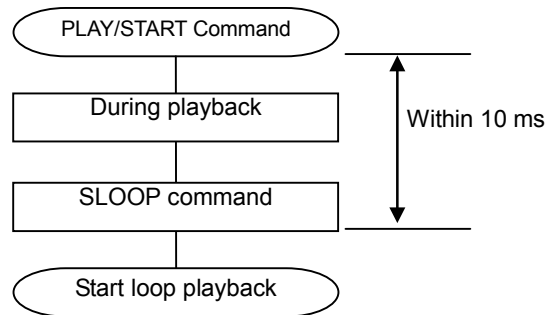

● Loop playback stop flow

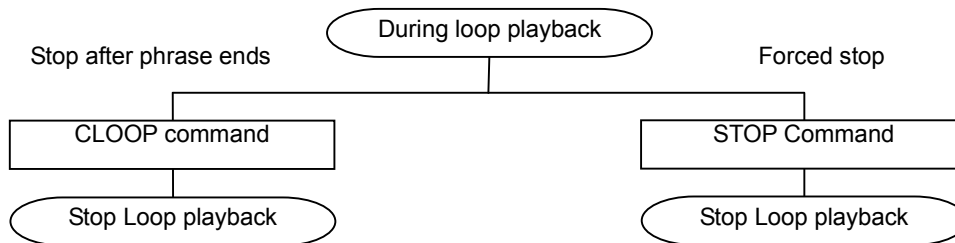

● Power-down flow

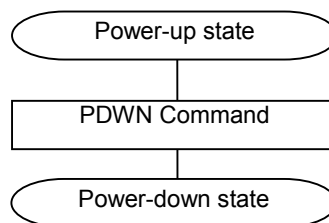

● Detailed flow of "Power-up → Playback → Power-down"

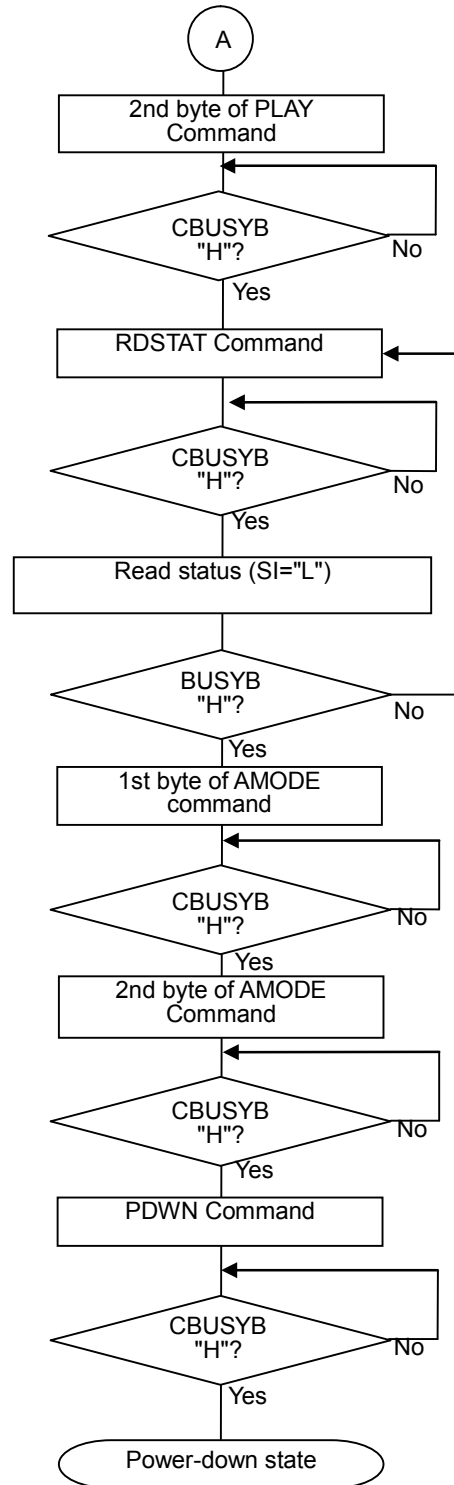
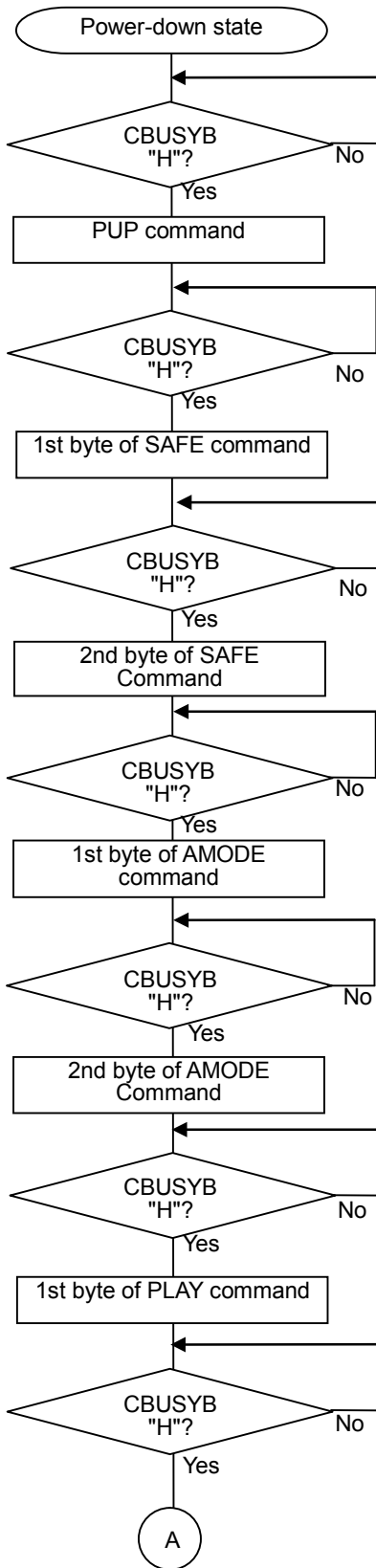

● Processing flow for speaker short detection

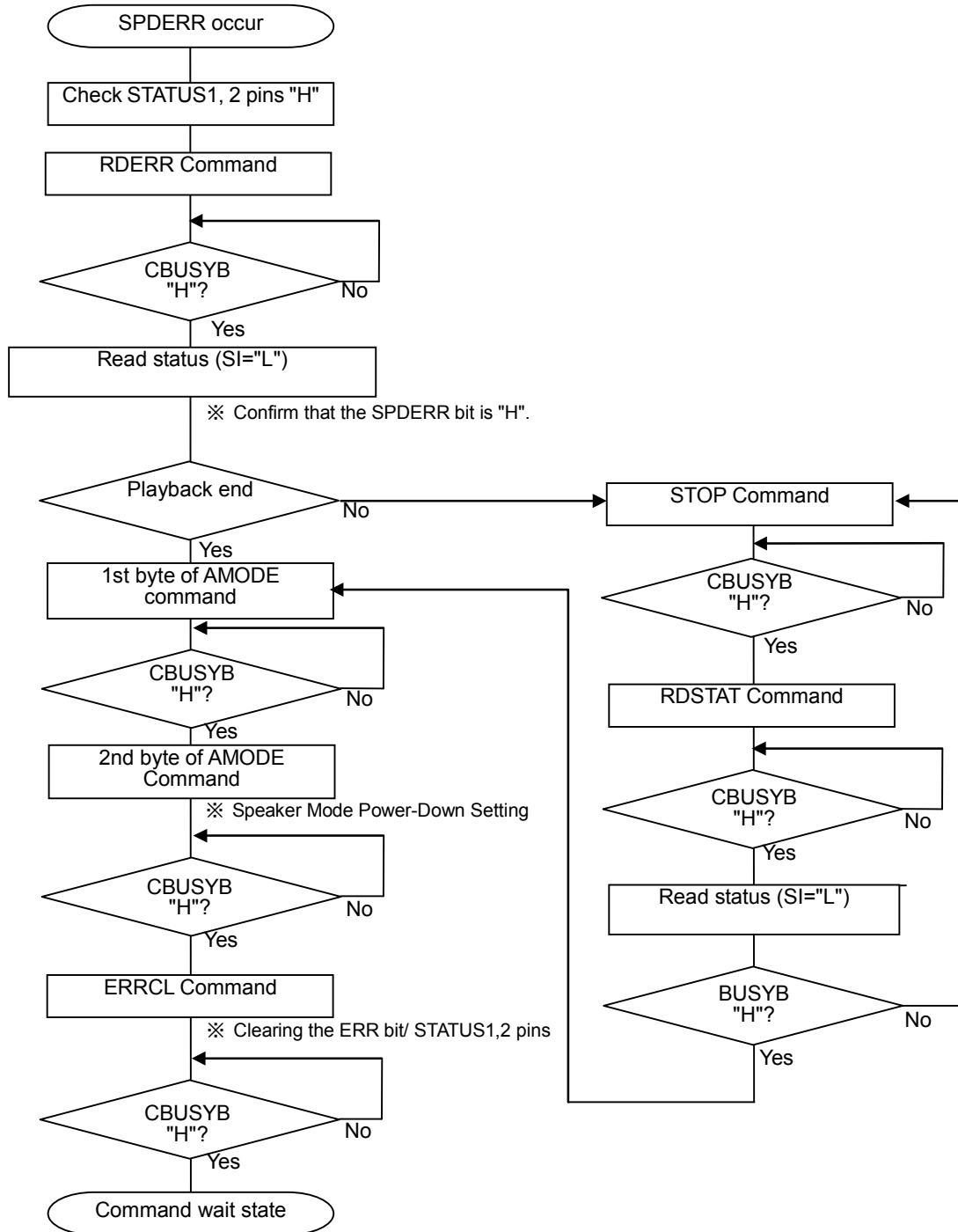



● 1-byte command input flow in two-times input mode

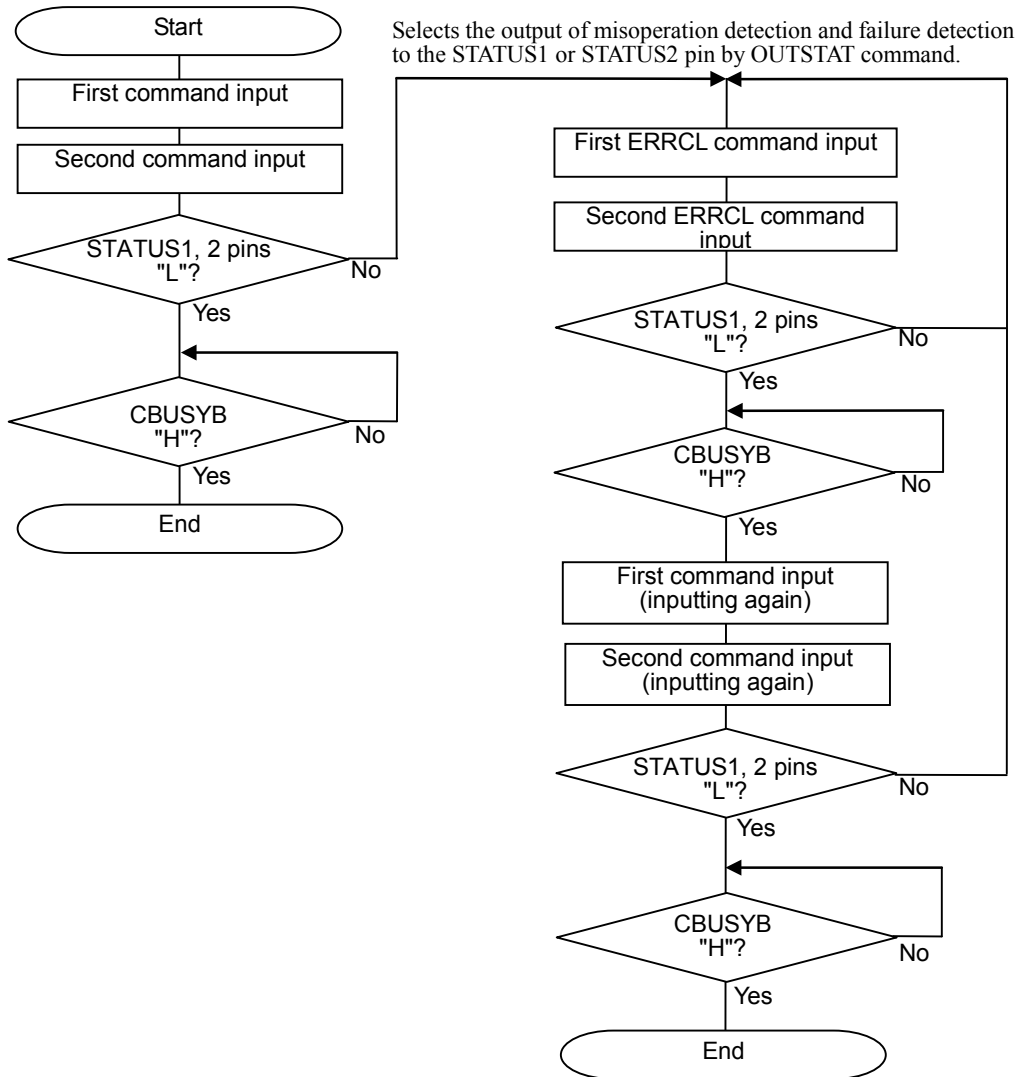

● 2-byte command input flow in two-times input mode

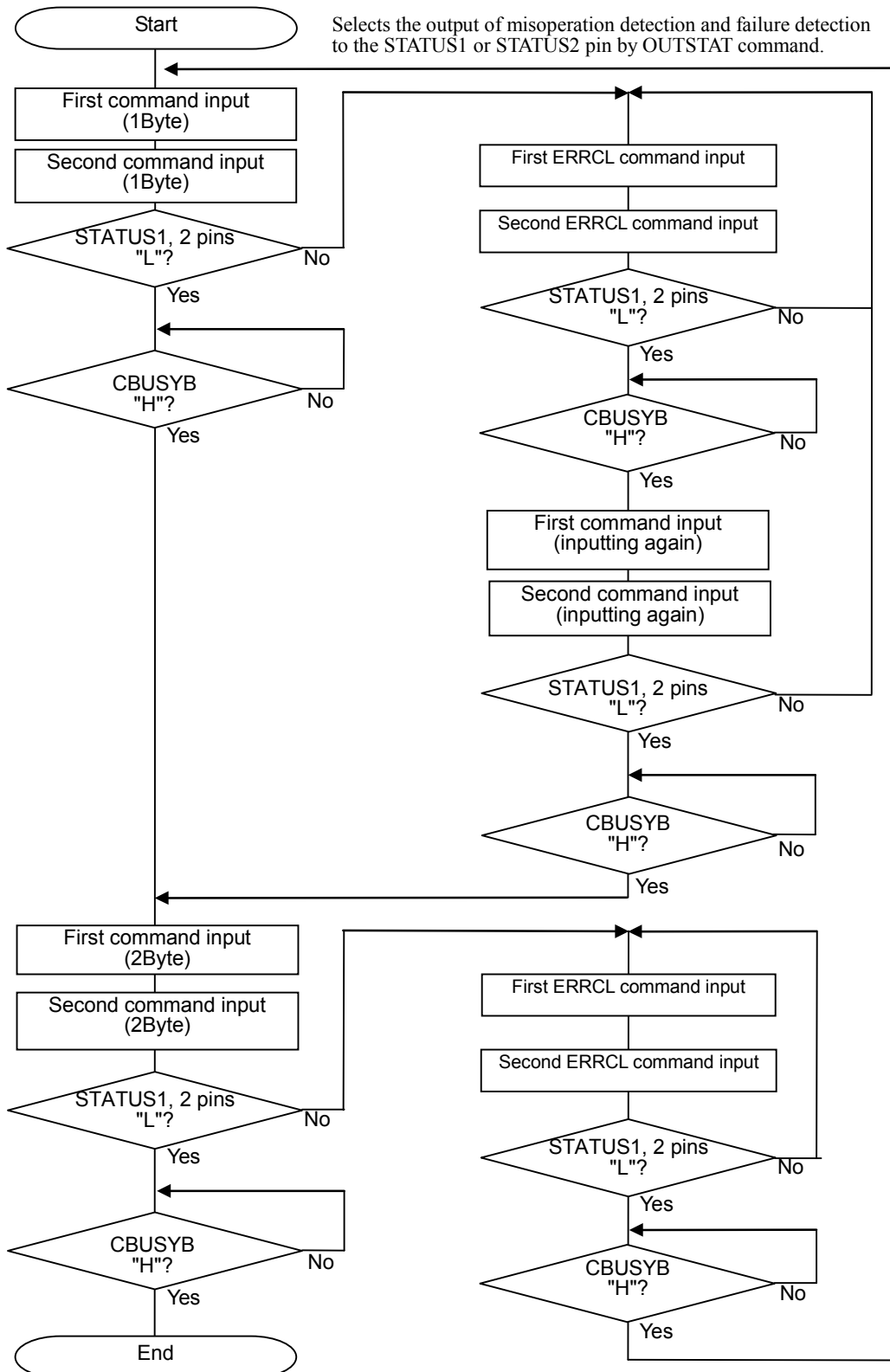

● 3-byte command input flow in two-times input mode

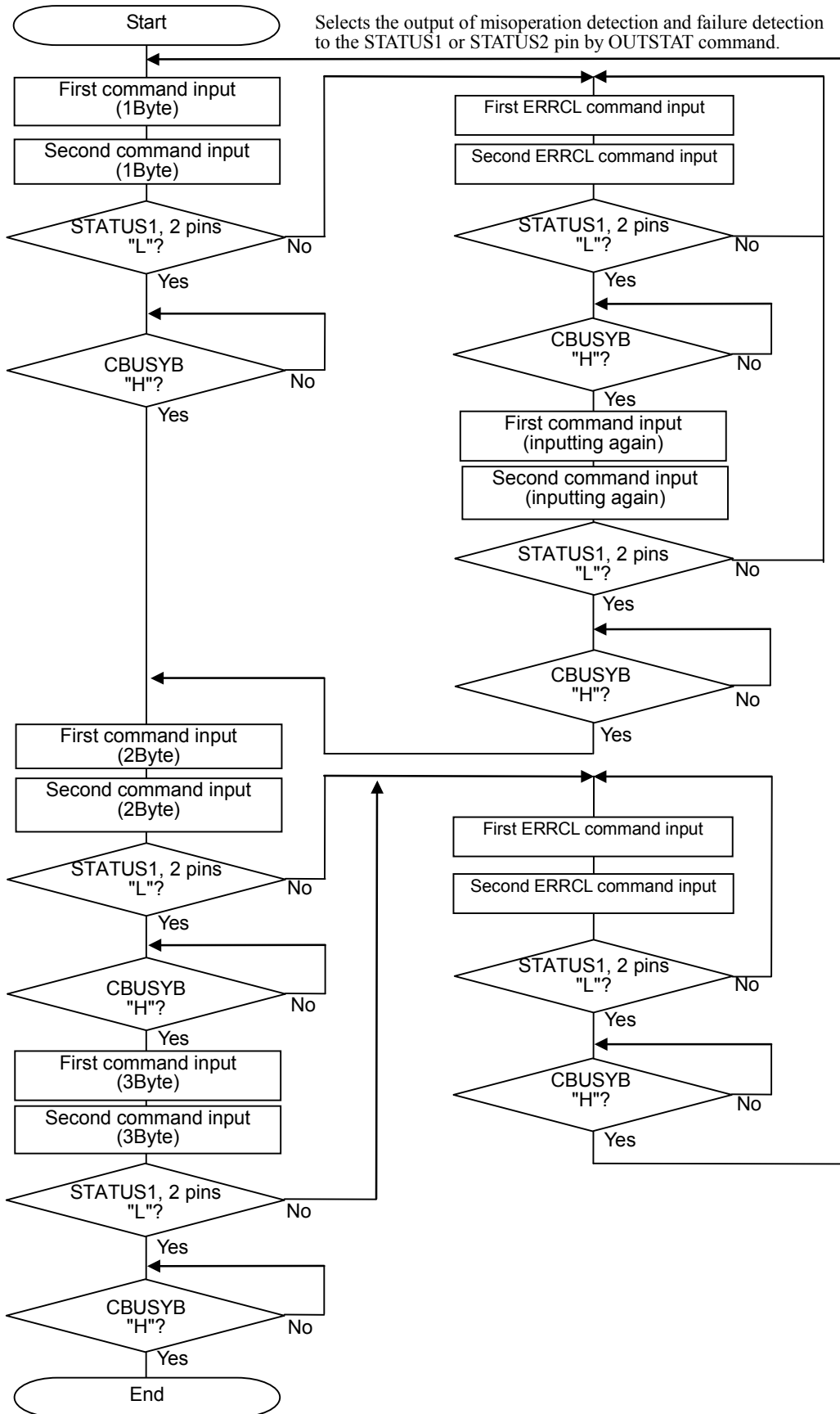

● Read flow in two-times input mode (Applies to RDSTAT and RDVER commands)

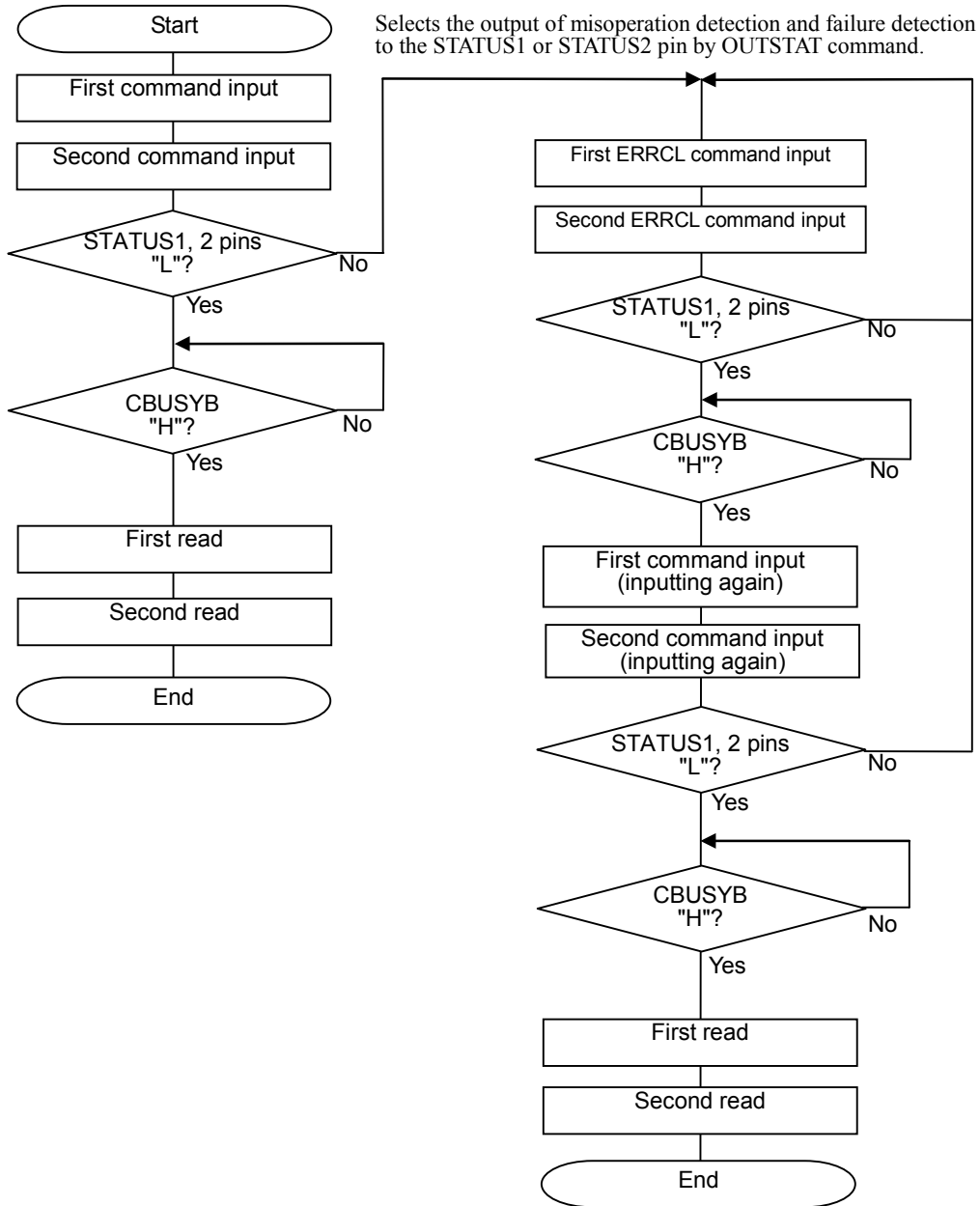

- Read flow in two-times input mode (Applies to RDERR command)

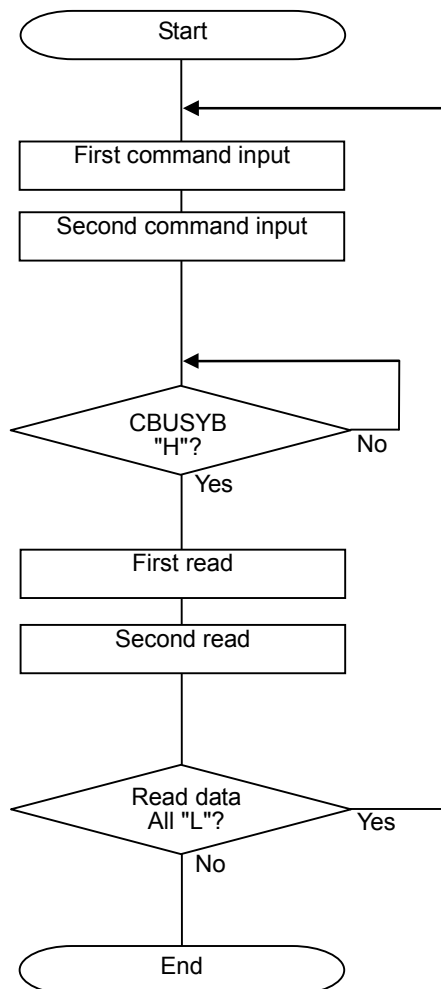

When the OUTSTAT command is used to select the misoperation detection and failure detection outputs and the STATUS1 or STATUS2 pin is "H", if all the read data is "L", the data cannot be read normally. Accordingly, read the data again.

- Read flow in the two-times input mode (applicable to the playback sound error detection command group)

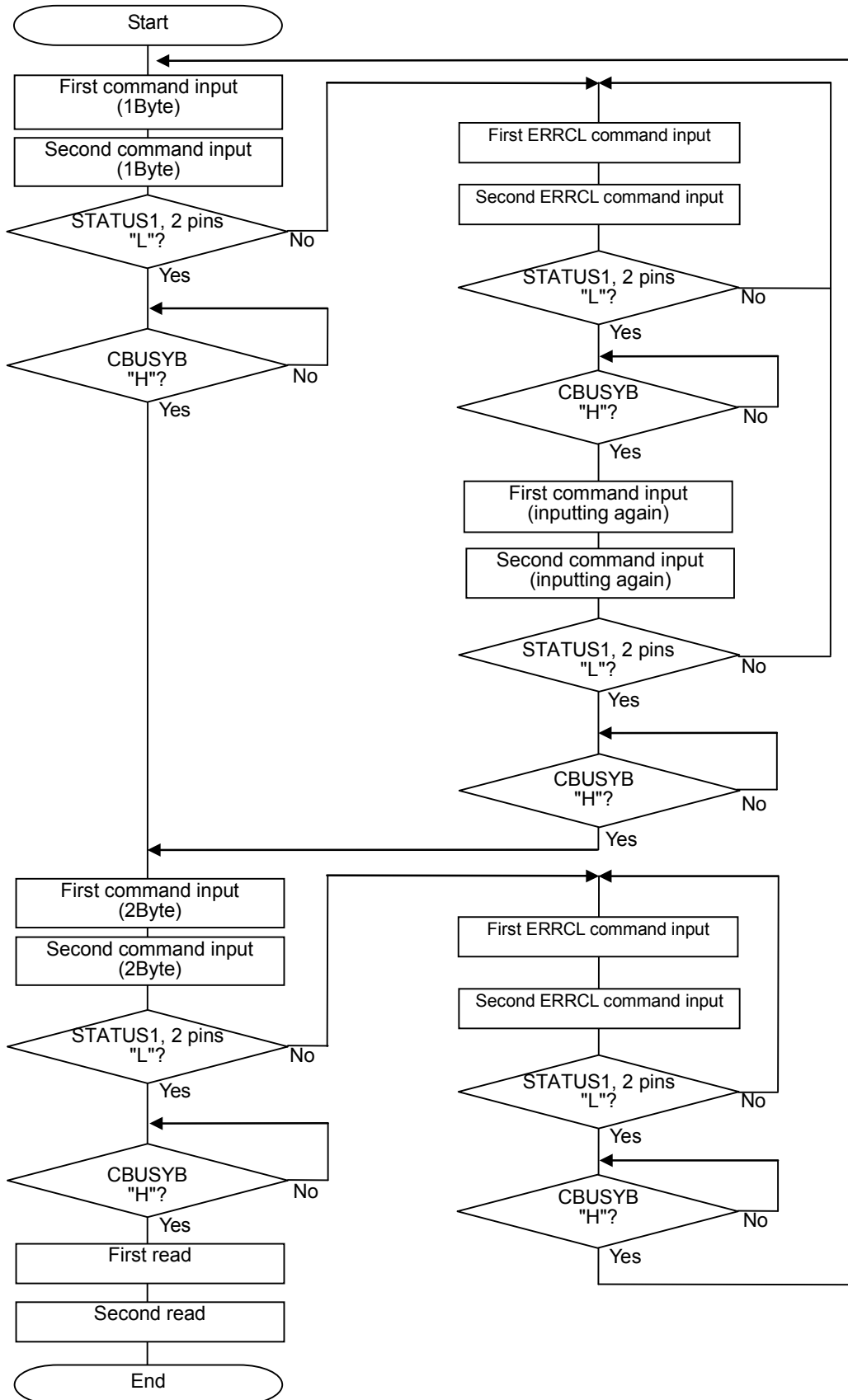

● SAI playback start flow

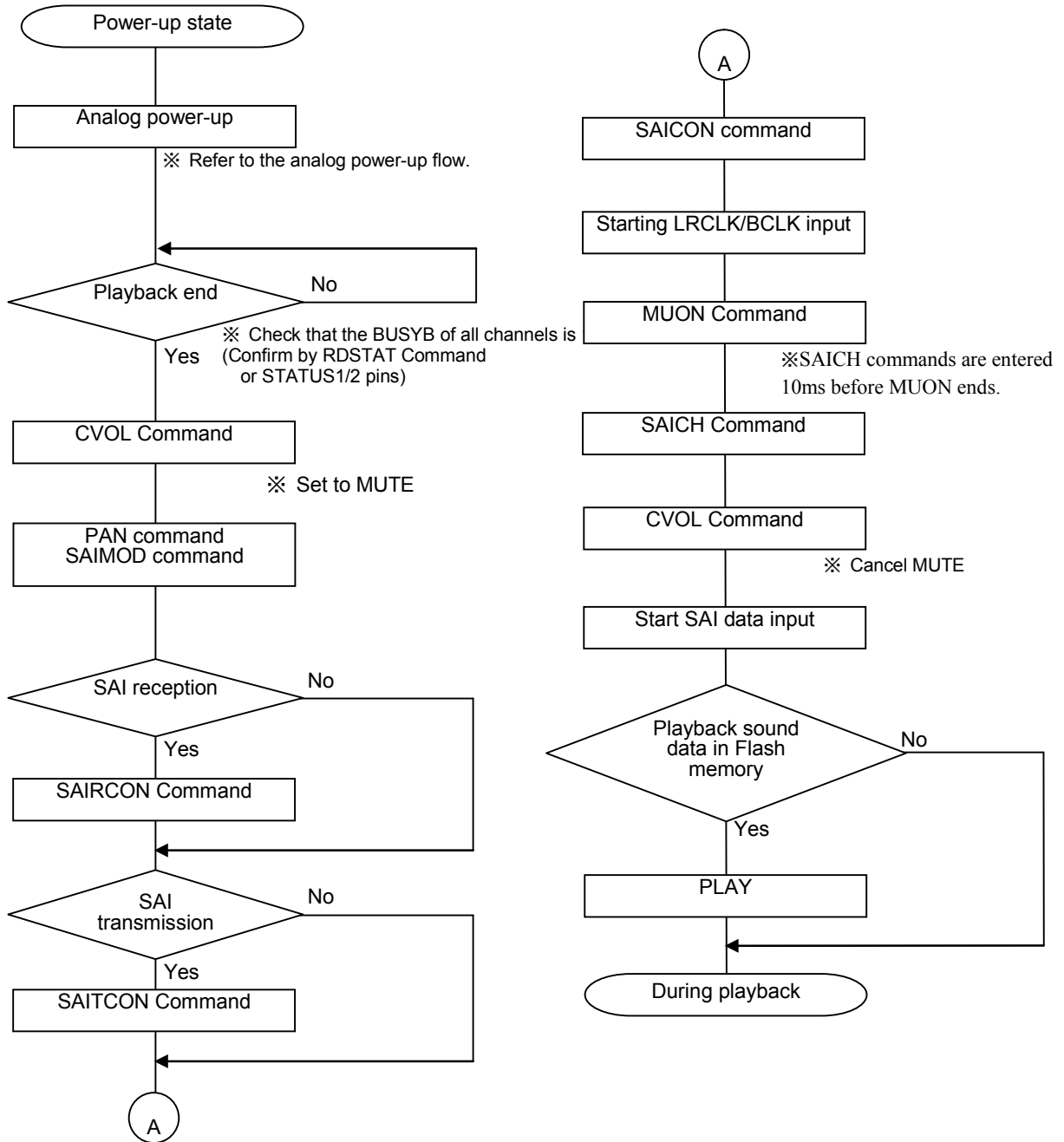

● SAI playback stop flow

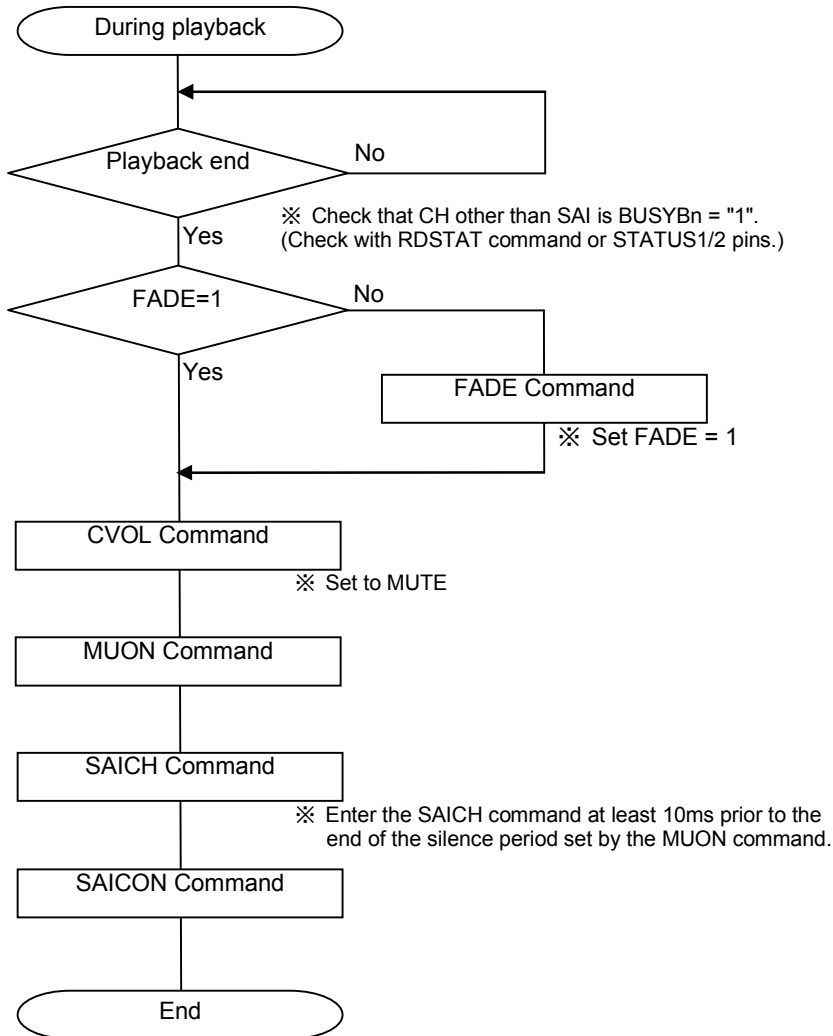



● Playback sound error detection start flow

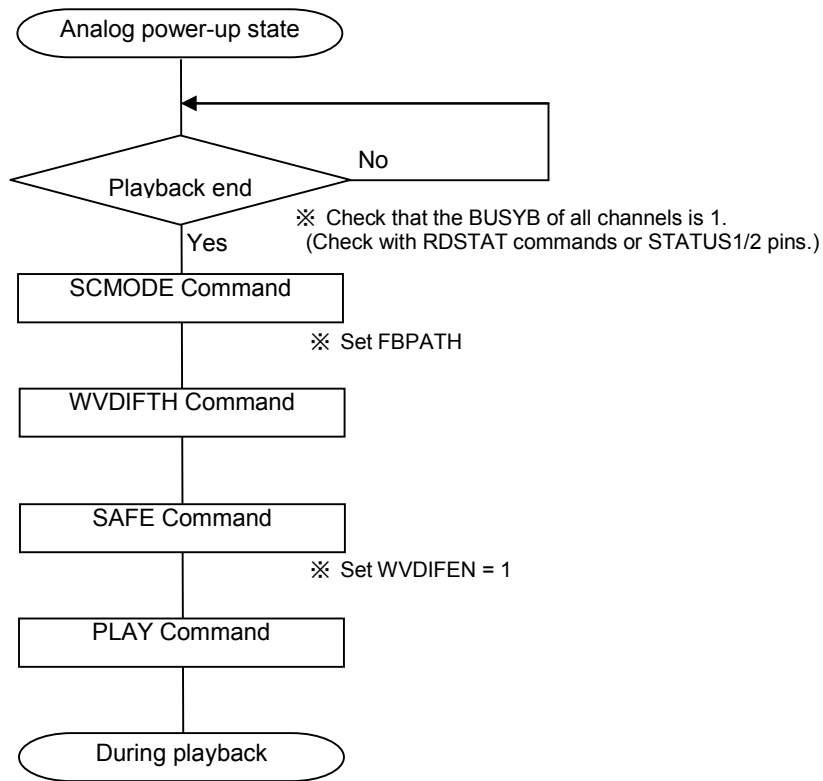

● AIN disconnection detection mode setting flow

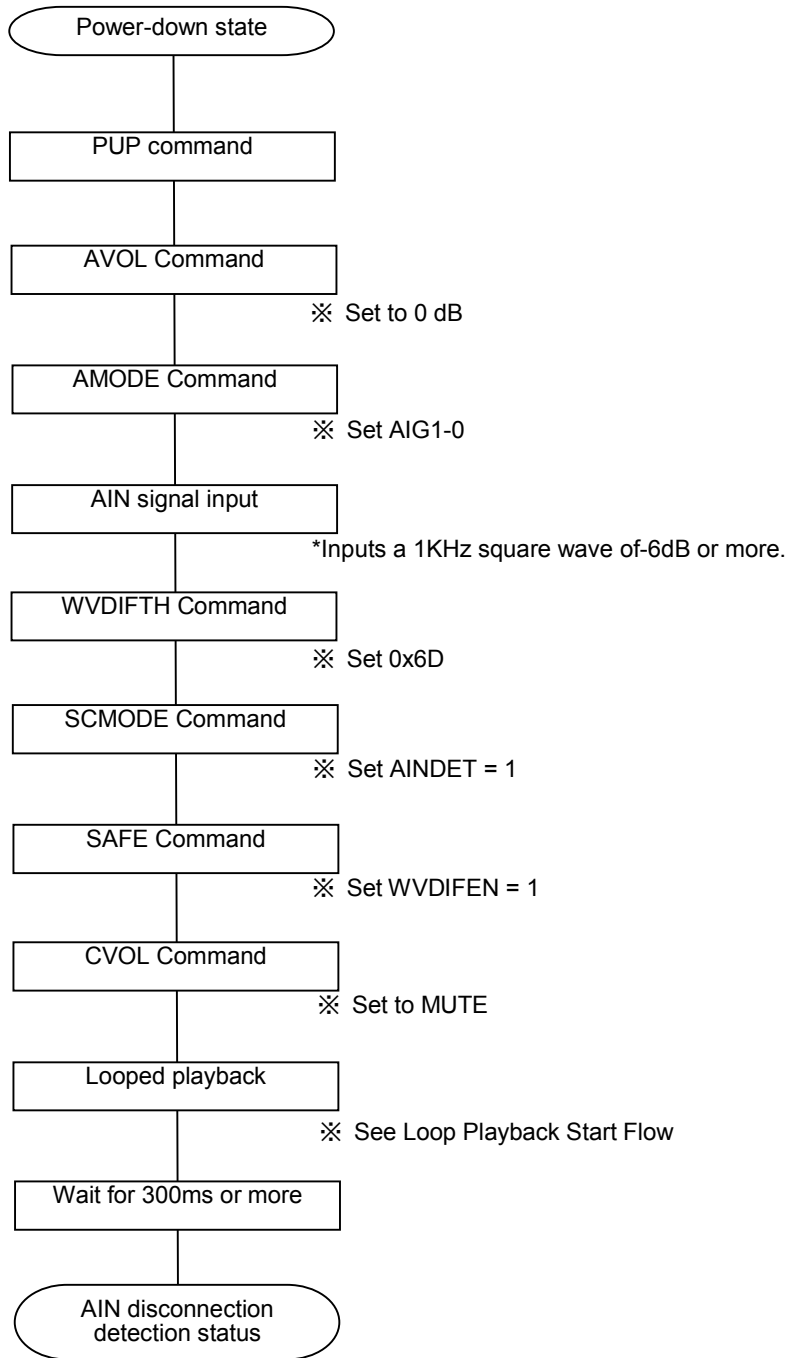

● AIN disconnection detection mode stop flow

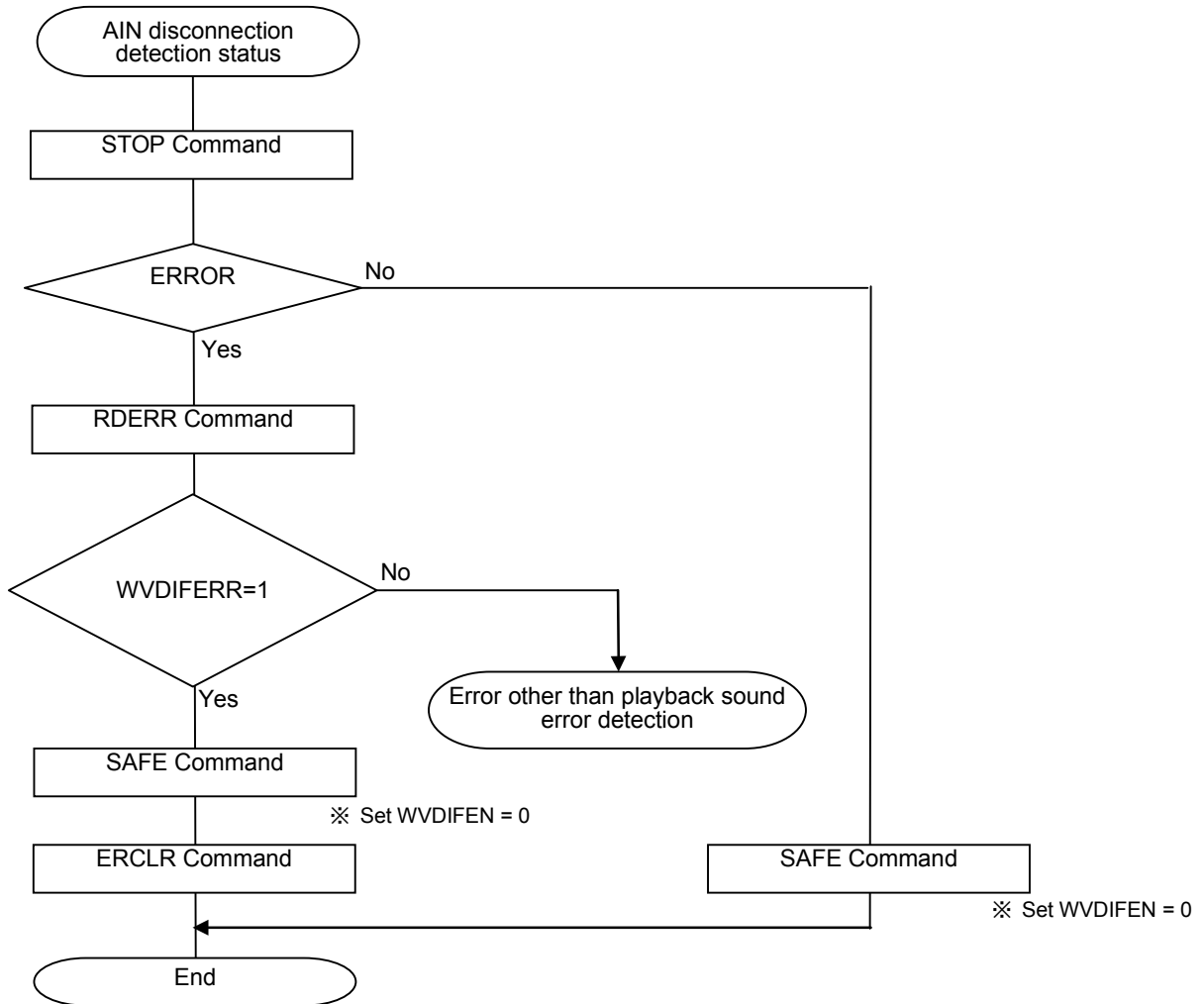

● Playback sound error detection stop flow

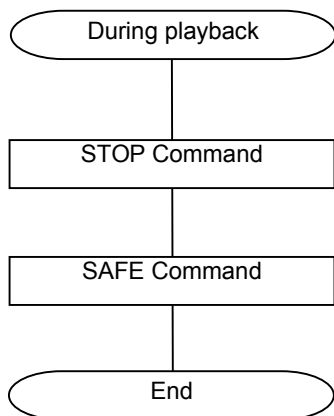

## ■ Peripheral circuit

### ● Handling of SG Pin

The SG pin is the signal ground for the built-in speaker amplifier. Connect a capacitor between this pin and the SPGND to prevent noises.

| Pin | Symbol | Recommended Constant  |
|-----|--------|-----------------------|
| SG  | C9     | 0.1 $\mu$ F $\pm$ 20% |

### ● Handling of V<sub>DDL</sub> Pins

The V<sub>DDL</sub> pin is a power supply for the internal circuits. Connect a capacitor across the DGND to prevent noises and power supply fluctuations. Please place it near the LSI on the user board.

| Pin              | Symbol | Recommended Constant |
|------------------|--------|----------------------|
| V <sub>DDL</sub> | C8     | 1 $\mu$ F $\pm$ 20%  |

### ● Handling of V<sub>DDR</sub> Pins

The V<sub>DDR</sub> pin is a power supply for the internal circuits. Connect a capacitor across the DGND to prevent noises and power supply fluctuations. Please place it near the LSI on the user board.

When using the DV<sub>DD</sub> power supply voltage of 2.7V to 3.6V, connect to the DV<sub>DD</sub> power supply.

| Pin              | Symbol | Recommended Constant |
|------------------|--------|----------------------|
| V <sub>DDL</sub> | C8     | 1 $\mu$ F $\pm$ 20%  |
| V <sub>DDR</sub> | C11    | 1 $\mu$ F $\pm$ 20%  |

### ● Power wiring

The power supply of this LSI is divided into the following three power supplies.

- Digital power supply (DV<sub>DD</sub>), digital GND (DGND)
- Speaker amplifier power supply (SPV<sub>DD</sub>, SPOV<sub>DD</sub>), Speaker amplifier GND (SPGND, SPOGND)
- Power supply for flash memory interface (IOV<sub>DD</sub>)

These power supplies can be used independently. However, use it in the condition of SPV<sub>DD</sub>=SPOV<sub>DD</sub> $\geq$ DV<sub>DD</sub>.

When using the same power supply, branch it from the root of the power supply for wiring.

### ● Bypass capacitor

To improve noise-resistance, place the bypass capacitor close to the LSI on the user board, and shorten the wiring as short as possible without passing through the via.

| Pin                                    | Symbol | Recommended Constant  |
|--|--------|-----------------------|
| SPV <sub>DD</sub> , SPOV <sub>DD</sub> | C3     | 3.3 $\mu$ F $\pm$ 20% |
| SPV <sub>DD</sub> , SPOV <sub>DD</sub> | C4     | 0.1 $\mu$ F $\pm$ 20% |
| DV <sub>DD</sub>                       | C5     | 3.3 $\mu$ F $\pm$ 20% |
| DV <sub>DD</sub>                       | C6     | 0.1 $\mu$ F $\pm$ 20% |
| IOV <sub>DD</sub>                      | C7     | 1 $\mu$ F $\pm$ 20%   |

### ● Coupling capacitor

Insert when analog input from AIN pin.

Insert when using LOUT and SPP pins as line amplifier output.

| Pin      | Symbol | Recommended Constant  |
|----------|--------|-----------------------|
| AIN      | C10    | 0.1 $\mu$ F $\pm$ 20% |
| LOUT/SPP | C12    | 0.1 $\mu$ F $\pm$ 20% |

■ Application Circuit

- Exclusive use of clock synchronous serial interface and I<sup>2</sup>C interface. (DV<sub>DD</sub>=2.7V to 3.6V)

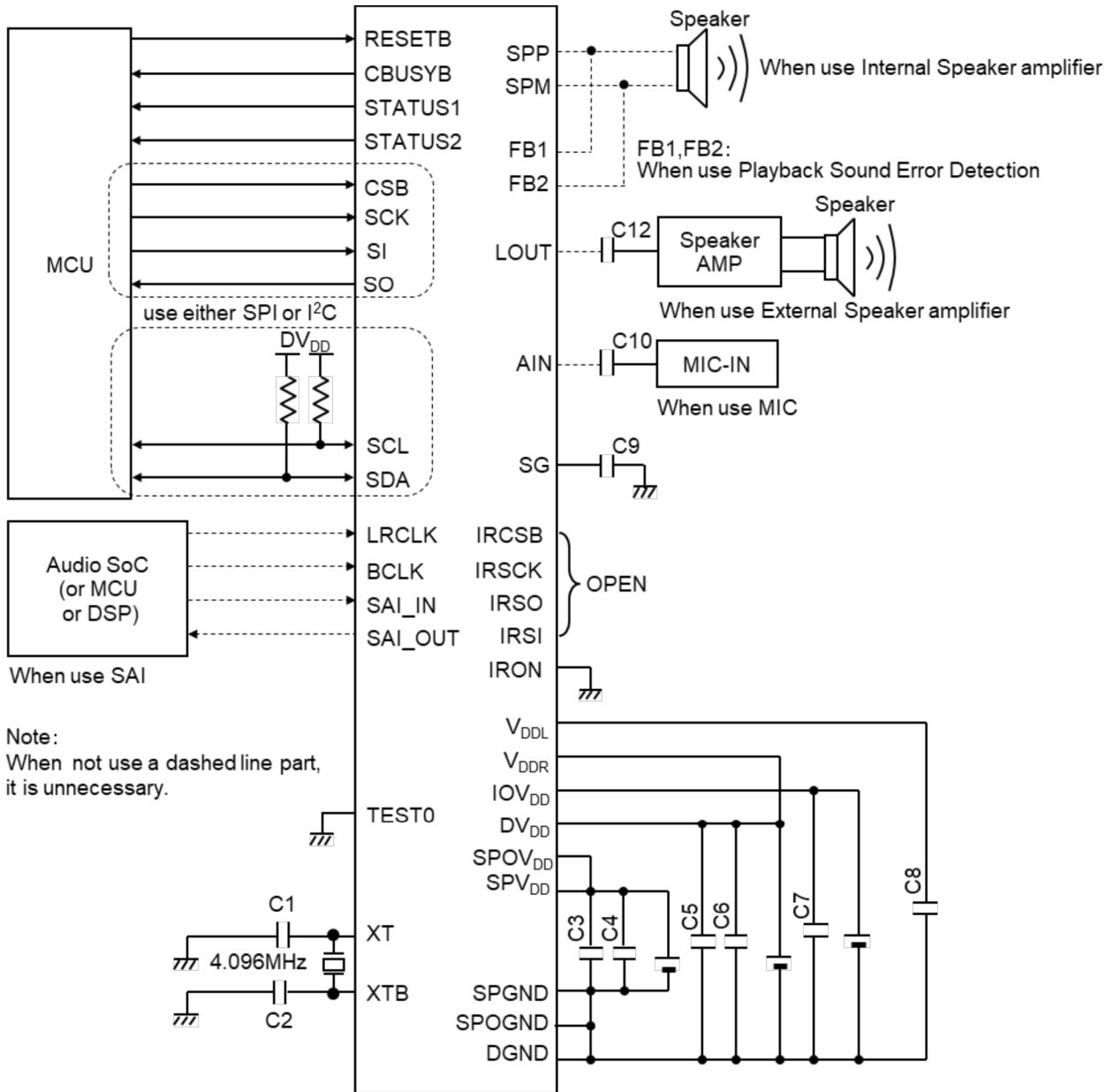

Note:  
When not use a dashed line part,  
it is unnecessary.

The V<sub>DDR</sub> handling differs from the case where DV<sub>DD</sub>=3.3V to 5.5V.

- Exclusive use of clock synchronous serial interface and I<sup>2</sup>C interface. (DV<sub>DD</sub>=3.3V to 5.5V)

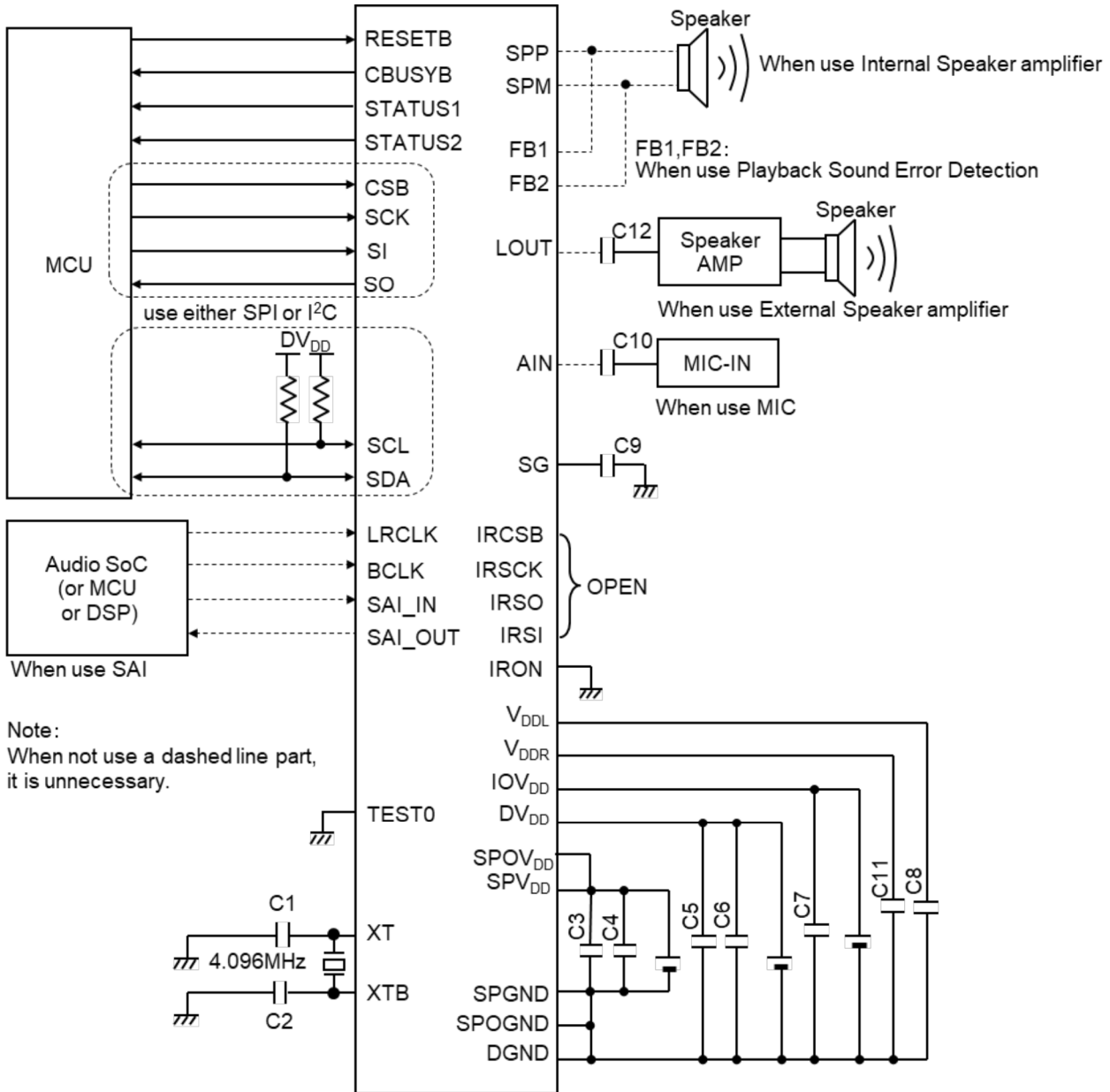

The V<sub>DDR</sub> handling differs from the case where DV<sub>DD</sub>=2.7V to 3.6V.

■ Recommended ceramic resonator

Recommended ceramic resonators are shown below.

● MURATA Corporation

| Frequency [Hz] | Product Name     | Built-in load capacity [pF] |
|----------------|------------------|-----------------------------|
| 4M             | CSTCR4M00G55B-R0 | 39                          |
| 4.096M         | CSTCR4M09G55B-R0 |                             |

■ RC4MHz characteristic

RC4MHz characteristic is as follows.

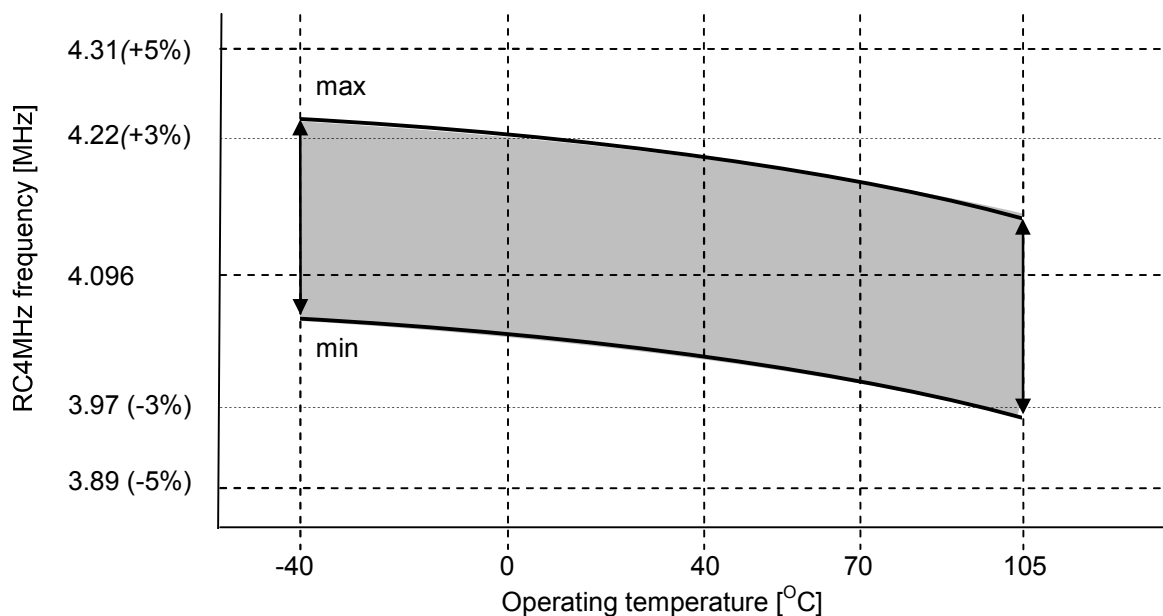

This graph is for reference only and does not guarantee the electrical characteristic.

■ Limitation on the operation time (Playback operating time)

This LSI operating temperature is 105°C (max). But the average ambient temperature at 1W playback (8ohm drive) for 10 years in the reliability design is Ta=65°C. (max (the package heat resistance  $\theta_{ja}$ =32.1[°C/W]))

When this LSI operates 1W playback (8ohm drive) consecutively, the product life changes by the package temperature rise by the consumption. This limitation does not matter in the state that a speaker amplifier does not play.

The factors to decide the operation time (playback operating time) are the average ambient temperature (Ta), playback Watts (at the speaker drive mode), the soldering area ratio, and so on. In addition, the limitation on the operation time changes by the heat designs of the board.

■ Package Heat Resistance Value (Reference Value) ( $\theta_{ja}$ )

The following table is the package heat resistance value  $\theta_{ja}$  (reference value). This value changes the condition of the board (size, layer number, and so on).

| Board   | $\theta_{ja}$ | $\Psi_{jc}$ | $\Psi_{jb}$ | Condition                               |
|---|---------------|-------------|-------------|---|
| JEDEC 4 layers *1<br>(W/L/t=76.2/114.5/1.6(mm)) | 32.1[°C/W]    | 0.70[°C/W]  | 12.2[°C/W]  | Air cooling condition:No wind<br>(0m/s) |
| JEDEC 2 layers *2<br>(W/L/t=76.2/114.5/1.6(mm)) | 38.3[°C/W]    | 0.74[°C/W]  | 13.0[°C/W]  | the soldering area ratio *3:100%        |

\*1 : The wiring density : 1st layer(Top) 60% / 2nd layer 100% / 3rd layer 100% / 4th layer(Bottom) 60%.

\*2 : The wiring density : 1st layer(Top) 60% / 2nd layer(Bottom) 100%.

\*3 : The soldering area ratio is the ratio that the heat sink area of this LSI and a land pattern on the board are soldered. 100% mean that the heat sink area of this LSI is completely soldered to the land pattern on the board. About the land pattern on the board, be sure to refer to the next clause (Package Dimensions).

The definition of each temperature is shown below.

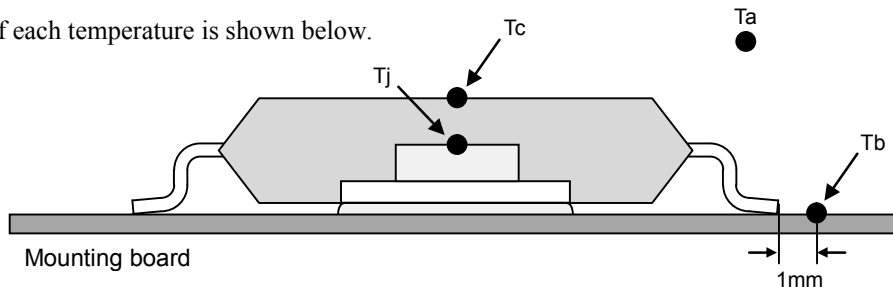

Take measures to dissipate heat on the mounting board so that the maximum junction temperature does not exceed 125°C.



■ Package Dimensions

● ML22Q53X-NNN/ML22Q53X-xxxTB

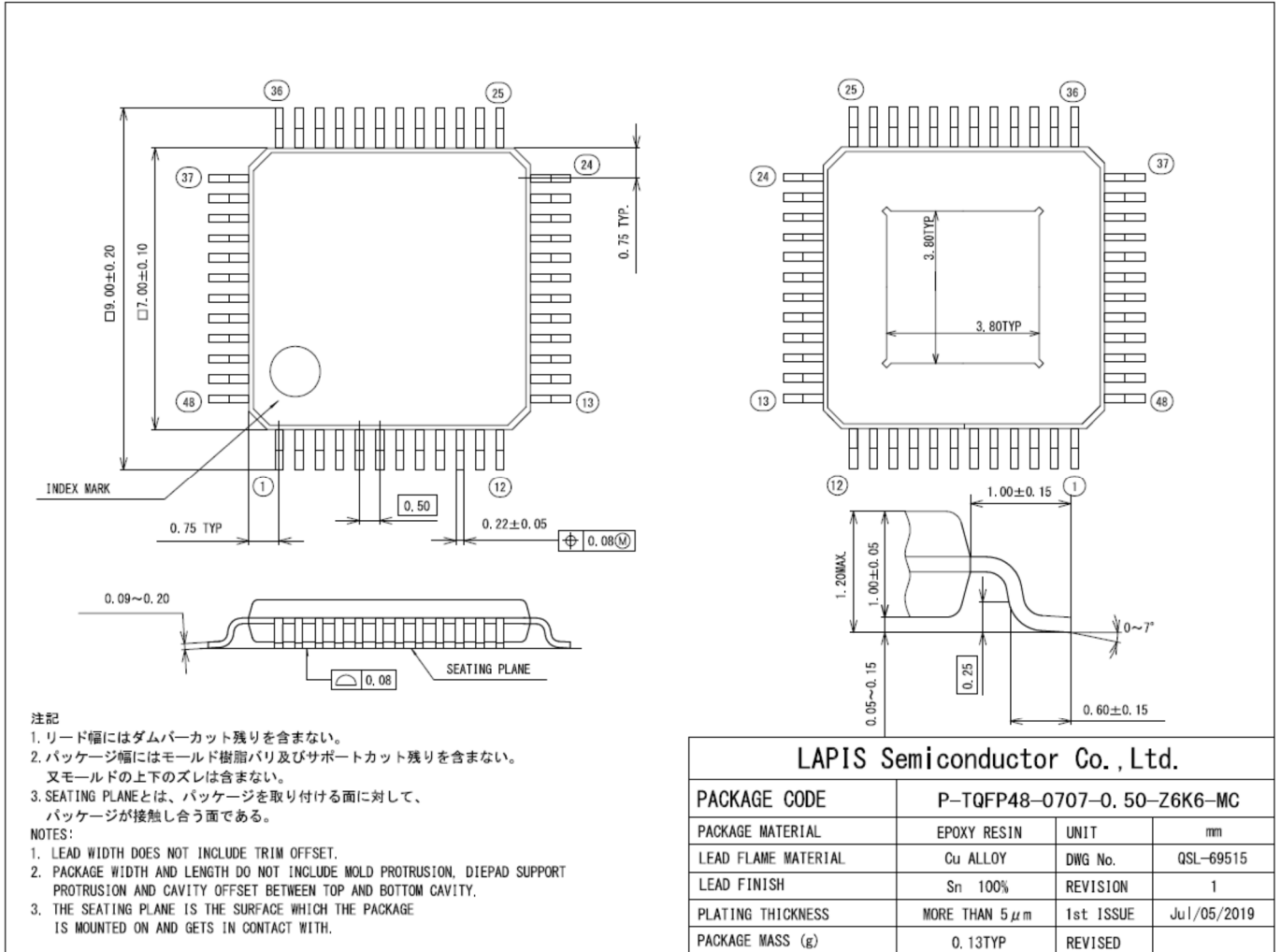

Notes for heat sink type Package

This LSI adopts a heat sink type package to raise a radiation of heat characteristic. Be sure to design the land pattern corresponding to the heat sink area of the LSI on a board, and solder each other. The heat sink area of the LSI solder open or GND on the board.

## 半田付け部端子存在範囲図

## Mounting area for package lead soldering to PC boards

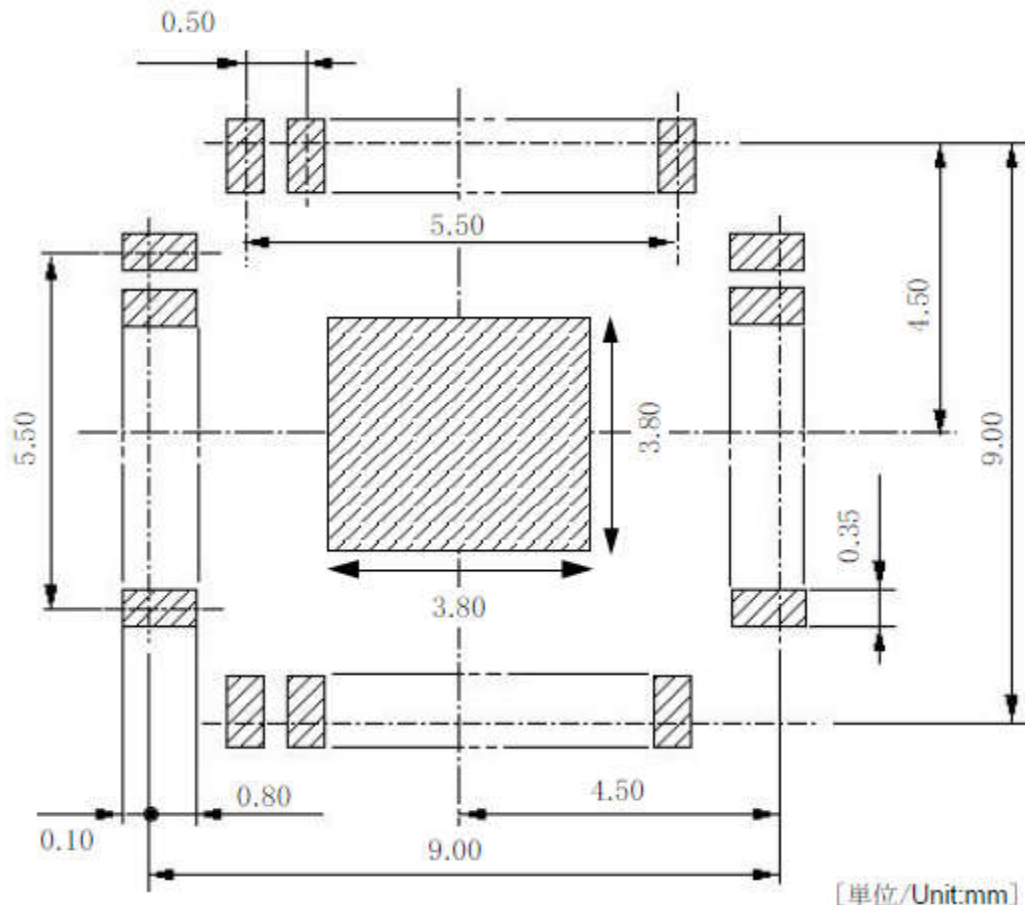

実装基板のフットパターンの設計の際には、実装の容易さ、接続の信頼性、配線の引き回し、半田ブリッジ発生のないことなどを十分考慮してください。

フットパターンの最適な設計は基板材質、使用する半田ペースト種類、厚み、半田付け方法などによって変わってきます。従って、本パッケージの端子の存在し得る範囲を「半田付け部端子存在範囲図」として示しますので、フットパターン設計の参考資料としてください。

When laying out PC boards, it is important to design the foot pattern so as to give consideration to ease of mounting, bonding, positioning of parts, reliability, wiring, and elimination of solder bridges.

The optimum design for the foot pattern varies with the materials of the substrate, the sort and thickness of used soldering paste, and the way of soldering. Therefore when laying out the foot pattern on the PC boards, refer to this figure which means the mounting area that the package leads are allowable for soldering to PC boards.

## Notes for Mounting the Surface Mount Type Package

The surface mount type packages are very susceptible to heat in reflow mounting and humidity absorbed in storage. Therefore, before you perform reflow mounting, contact a ROHM sales office for the product name, package name, pin number, package code and desired mounting conditions (reflow method, temperature and times).

■ Differences from Existing Speech Synthesis LSIs (ML22Q553/ML22594)

| Parameter                     |  | ML22Q553   | ML22594   | ML22Q53X  |
|-------------------------------|--|--|---|---|
| MCU command interface         |  | Clock synchronous serial (1 channel)   | ←   | Clock synchronous serial I <sup>2</sup> C (2 channels)  |
| Serial Audio Interface (SAI)  |  | -  | ←   | Yes   |
| Clock frequency               |  | 4.096MHz (Built-in crystal oscillation circuit)                              | ←   | 4.096MHz (crystal oscillation circuit/built-in RC oscillation)  |
| Memory capacity               | Built  | 4Mbits (flash memory)  | 6Mbits(mask rom)  | 532: 2Mbits (flash memory)<br>533: 4Mbits (flash memory)<br>535: 16Mbits (flash memory)                                     |
|                               | External   | -  | Up to 128Mbits  | -   |
| Flash memory rewrite function |  | JTAG interface   | -   | Flash memory interface<br>MCU command interface (clock synchronous serial)  |
| Sound function                | Speech synthesis algorithm                       | HQ-ADPCM<br>8-bit non-linear PCM<br>8bit straight PCM<br>16-bit straight PCM | ←   | HQ-ADPCM<br>4bit ADPCM2<br>8-bit non-linear PCM<br>8bit straight PCM<br>16-bit straight PCM                                 |
|                               | Sampling frequency (kHz)                         | 6.4/12.8/25.6<br>8.0/16.0/32.0<br>12.0/24.0/48.0                             | ←   | 6.4/12.8/25.6<br>8.0/16.0/32.0<br>10.7/21.3<br>11.025/22.05/44.1<br>12.0/24.0/48.0  |
|                               | Simultaneous sounding function (Mixing-function) | 4 channels   | ←   | ←   |
|                               | Maximum number of phrases                        | 1024   | ←   | 4096  |
|                               | Edit ROM function                                | Yes  | ←   | ←   |
|                               | Silence insertion function                       | 20ms to 1024ms (4ms step)  | ←   | ←   |
|                               | Repeat function                                  | Yes  | ←   | ←   |
|                               | Playback sound and SAI mixing functions          | -  | ←   | Yes   |
| Low-pass filter               |  | FIR type interpolation filter  | ←   | ←   |
| D/A converter                 |  | Voltage type 16-bit  | ←   | ←   |
| Speaker amplifier (Class AB)  |  | 1.0W@8Ω (SPV <sub>DD</sub> =5V)  | ←   | ←   |
| Volume adjustment function    | Digital  | 32 levels  | ←   | 128 levels  |
|                               | Analog   | 50 levels  | ←   | 16 levels   |
|                               | Fade function                                    | -  | ←   | Yes   |
| External analog input         |  | Yes  | ←   | ←   |
| Failure detection functions   | Clock error detection                            | -  | ←   | Yes   |
|                               | Playback sound error detection                   | -  | ←   | Yes   |
|                               | Power supply voltage detection                   | Yes  | ←   | -   |
|                               | Thermal detection                                | Yes  | ←   | ←   |
|                               | Speaker pin ground fault detection <sup>*1</sup> | Yes  | ←   | ←   |
|                               | Speaker pin short detection <sup>*1</sup>        | Yes  | ←   | ←   |
|                               | Speaker disconnection detection                  | -  | ←   | Yes   |
| Power-supply voltage          |  | DV <sub>DD</sub> =SPV <sub>DD</sub> =4.5 to 5.5V                             | DV <sub>DD</sub> =SPV <sub>DD</sub> =4.5 to 5.5V<br>IOV <sub>DD</sub> =2.7V to 5.5V | DV <sub>DD</sub> =2.7 to 5.5V<br>SPV <sub>DD</sub> =SPOV <sub>DD</sub> ≥DV <sub>DD</sub><br>IOV <sub>DD</sub> =2.7V to 5.5V |
| Operating temperature         |  | -40 to 105°C   | ←   | ←   |
| Package                       |  | 30-pin SSOP  | ←   | 48-pin TQFP   |

\*1 The ground fault detection and short-circuit detection functions can be used when the SPV<sub>DD</sub> is 4.5V or higher.

### ■ Speech LSI Utility Setting Items

Set the following items on the Speech LSI Utility.

| Item   | Description   |
|--|---|
| Protection code for flash memory access                                | Set any 8-bit data.<br><ul style="list-style-type: none"> <li>• 0x69: Flash memory cannot be accessed by the FDIRECT command.</li> <li>• Other than 0x69: Accessing the flash memory is enabled when the protection unlock data entered by the FDIRECT command matches the data.</li> </ul> |
| Master clock selection   | Select master clock(Source clock oscillation).<br><ul style="list-style-type: none"> <li>• RC (RC oscillation)</li> <li>• Xtal (Crystal or ceramic resonator)</li> </ul>  |
| Master clock frequency   | Set the master clock frequency to F <sub>OSC</sub> .<br><ul style="list-style-type: none"> <li>• 4.096 : 4.096MHz setting</li> <li>• 4.000 : 4.000MHz setting</li> </ul>  |
| Number of phrases used   | Select the number of phrases from the following.<br><ul style="list-style-type: none"> <li>• 4096</li> <li>• 3072</li> <li>• 2048</li> <li>• 1024</li> </ul>  |
| Sound ROM information  | Set any 8-bit data.<br>Read by RDVER command.   |
| Class D amplifier output format  | Output format selection.<br><ul style="list-style-type: none"> <li>• Half-wave mode</li> <li>• Full wave mode is not supported.</li> </ul>  |
| WDT counter, RST counter<br>WDTERR or RSTERR<br>processing at overflow | Select the processing to be performed when an overflow occurs.<br><ul style="list-style-type: none"> <li>• Hold current state</li> <li>• Transition to the state after PUP command input</li> </ul>   |
| WDT counter, RST counter<br>WDTERR or RSTERR<br>overflow time          | Select the overflow time from the following.<br><ul style="list-style-type: none"> <li>• 125ms</li> <li>• 500ms</li> <li>• 2s</li> <li>• 4s</li> </ul>  |

Refer to the Speech LSI Utility User's Manual for more information.

## ■ Check lists

This check list has notes to frequently overlooked or misunderstood hardware features of the LSI. Check each note listed up chapter by chapter while coding the program or evaluating it using the LSI.

## ■ Feature

- [ ] \*1 Mixing with SAI is limited by the sampling frequency. Refer to the "Function description".
- [ ] \*2 Handle  $V_{DDR}$  pin in two different ways depending on the voltage range 2.7-3.6V or 3.3-5.5V. Refer to the "Application Circuit".
- [ ] \*3 The operating time of the speaker amplifier may be limited depending on the average ambient temperature ( $T_a$ ) used.

## ■ Pin Description

- [ ] (SCL pin) When using an I<sup>2</sup>C, be sure to insert a pull-up resistor between DV<sub>DD</sub> pin.
- [ ] (SCL pin) Accessing with clock synchronous serial interface at the same time is prohibited.
- [ ] (SDA pin) When using an I<sup>2</sup>C, be sure to insert a pull-up resistor between DV<sub>DD</sub> pin.
- [ ] (SDA pin) Accessing with clock synchronous serial interface at the same time is prohibited.
- [ ] (CSB pin) Accessing with I<sup>2</sup>C slave interface at the same time is prohibited.
- [ ] (SCK pin) Accessing with I<sup>2</sup>C slave interface at the same time is prohibited.
- [ ] (SI pin) Accessing with I<sup>2</sup>C slave interface at the same time is prohibited.
- [ ] (SO pin) Accessing with I<sup>2</sup>C slave interface at the same time is prohibited.
- [ ] (IRON pin) Set this bit to "L" during playback operation using flash memory.
- [ ] (IRON pin) Set this bit to "H" for onboard rewriting.
- [ ] (IOV<sub>DD</sub> pin) Connect to DV<sub>DD</sub> pin even when not using serial flash memory interface.
- [ ] (IOV<sub>DD</sub> pin) Connect a bypass capacitor between this pin and the DGND pin.
- [ ] (V<sub>DDR</sub> pin) Connect a capacitor between this pin and DGND pin as close as possible.
- [ ] (V<sub>DDR</sub> pin) Connect this pin to the DV<sub>DD</sub> pin when DV<sub>DD</sub> = 2.7 to 3.6V.
- [ ] (XTB pin) When using a resonator, connect it as close as possible.
- [ ] (XTB pin) Leave it open when not in use.
- [ ] (XT pin) To use an external clock, input from this pin. Delete the capacitor when a crystal or ceramic resonator is connected.
- [ ] (XT pin) When using a resonator, connect it as close as possible.
- [ ] (XT pin) Leave it open when not in use.
- [ ] (DV<sub>DD</sub> pin) Connect a bypass capacitor between this pin and the DGND pin.
- [ ] (V<sub>DDL</sub> pin) Connect a capacitor between this pin and DGND pin as close as possible.
- [ ] (SG pin) Connect a capacitor between this pin and SPGND pin.
- [ ] (SPV<sub>DD</sub> pin) Connect a bypass capacitor between this pin and the SPGND pin.
- [ ] (SPOV<sub>DD</sub> pin) Set it at the same potential as the SPV<sub>DD</sub>.
- [ ] (SPOGND pin) Set it at the same potential as the SPGND.
- [ ] (RESETB pin) At power-on, input an "L" level to this pin. After the power supply voltage stabilizes, set this pin to an "H" level.
- [ ] (TEST0 pin) Fix to the DGND.
- [ ] (CBUSYB pin) Be sure to input a command with this pin at an "H" level.
- [ ] (N.C. pin) Unused pin. Leave open.

## ■ Termination of Unused Pins

- [ ] Confirm the recommended termination of unused pins in this chapter.

## ■ Electrical characteristics

### ● Recommended operating conditions

- [ ] \*1 Be sure to  $SPV_{DD} = SPOV_{DD} \geq DV_{DD}$ .

## ■Function description

### ●I<sup>2</sup>C interface (Slave)

[ ] When I2C is used, be sure to insert a pull-up resistor between SCL and SDA pins and DV<sub>DD</sub> pin.

#### ◆Command flow when reading data

[ ] The data to be read is updated by inputting RDSTAT/RDERR/RDVER command. Be sure to enter the RDSTAT/RDERR/RDVER command before reading the internal status.

### ●SAI(Serial Audio Interface)

[ ] To use SAI, use AMODE commands to place the SAI into the analog power-up status.

### ●Mixing function

#### ◆Restrictions when using Serial Audio Interface(SAI)

[ ] When the serial audio interface (SAI) is used, there are some limitations to the maximum number of mixing and playable channels depending on the sampling frequency.

[ ] When mixing at the sampling frequencies of 8.0/16.0/32.0kHz with using Serial Audio Interface(SAI), HQ-ADPCM cannot be used.

#### ◆Waveform clamp precautions for mixing

[ ] If the clamp is known to be generated in advance, adjust the volume of each channel by CVOL and PAN commands.

#### ◆Different sampling frequency mixing algorithm

[ ] It is not possible to perform channel mixing by a different sampling frequency group. Note that when channel synthesis is performed on a sampling frequency group other than the selected sampling frequency group, playback will be faster or slower.

### ●Misoperation detection and failure detection functions

#### ◆SPP pin and SPM pin short detection

[ ] After inputting SAFE command, start the analog power-up operation by AMODE command within 10ms.

#### ◆Flash memory error detection

[ ] If the error bit (ROMERR) is set to "1" after the PUP command and before the PLAY command or START command starts playback, this LSI may have error at the time of start. In such cases, initialize this LSI by moving the LSI to the power-down mode by resetting the LSI by the RESETB pin or by using PDWN command.

#### ◆Detects the stop of clock input from a crystal resonator or ceramic resonator

[ ] If the RDERR command (first byte) is inputted before the crystal or ceramic resonator stops and switches to RC oscillation (about 500μs), the CBUSYB pin will remain "L". Therefore, read the command after the CBUSYB pin becomes "H".

[ ] When the crystal resonator or the ceramic resonator stops and switches to RC oscillation, playback may become abnormal. Therefore, after confirming that the error bit (OSCERR) is "1", enter STOP command to stop playback.

#### ◆Detects disconnection/short circuit of LRCLK

[ ] \*5 The unit does not recover even if a normal LRCLK is input after stopping playback. Enter MUON command →SAICH command after inputting a normal LRCLK.

#### ◆Detects disconnection/short circuit of SAI\_IN

[ ] When OUTEN is set to "1" and INEN is set to "0" by the SAICON command, the SAI\_IN input is disabled. Therefore, set SAIINEN to "0".

#### ◆Mixing number error detection

[ ] When using the serial audio interface (SAI), the sampling frequency limits the maximum number of mixings and playable channels.

## ■Timing chart

### ●Common

#### ◆Power-on timing

[ ] Start up in the order of DVDD, SPVDD and IOVDD or DVDD, IOVDD and SPVDD.

[ ] Be sure to input "L" to the RESETB pin before inputting the first command after power-on.

[ ] Be sure to enter "L" at the RESETB pin when the DVDD is below the (recommended) operating voltage range.

#### ◆Power-off timing

[ ] Shut down in the order of IOVDD, SPVDD, and DVDD or SPVDD, IOVDD, and DVDD.

[ ] Shut down each power supply after changing to the power down status with PDWN commands.

- Clock synchronous serial
  - ◆ Change volume timing by AVOL command
    - [ ] Speaker amplifier volume setting by AVOL commands is valid only when Class AB speaker amplifier is used. When a Class D speaker amplifier is used, the setting value is ignored and +0.0dB is selected.
  - ◆ Continuous playback timing by PLAY command
    - [ ] When making continuous playbacks, input the PLAY command for the next phrases within the specified time period (tcm) after the NCR of the corresponding channel changes to "H" level.
    - [ ] When the playback is not continuous, input the PLAY command for the next phrases after confirming the playback is completed by RDSTAT command and etc.
  - ◆ Continuous playback timing by START command
    - [ ] When making continuous playbacks, send the START command for the next phrases within the specified time period (tcm) after the NCR of the corresponding channel changes to "H" level.
    - [ ] When the playback is not continuous, input the START command for the next phrases after confirming the playback is completed by RDSTAT command, etc.
  - ◆ Continuous playback timing by MUON command
    - [ ] When making continuous playbacks, input the MUON/PLAY/START command for the next phrases within 10ms (tcm) after the NCR of the corresponding channel changes to "H" level. When the playback is not continuous, input the MUON/PLAY/START command for the next phrases after confirming the playback is completed by RDSTAT command and etc.
  - ◆ Repeat playback setting/release timing by SLOOP/CLOOP command
    - [ ] The SLOOP command is valid only during playback. After the PLAY command is input, input the SLOOP command within the specified period (tcm) after the NCR of the corresponding channel becomes "H" level.
- I2C Interface (Slave)
  - ◆ Change volume timing by AVOL command
    - [ ] Speaker amplifier volume setting by AVOL commands is valid only when Class AB speaker amplifier is used. When a Class D speaker amplifier is used, the setting value is ignored and +0.0dB is selected.
  - ◆ Continuous playback timing by PLAY command
    - [ ] When making continuous playbacks, input the PLAY command for the next phrases within the specified time period (tcm) after the NCR of the corresponding channel changes to "H" level.
    - [ ] When the playback is not continuous, input the PLAY command for the next phrases after confirming the playback is completed by RDSTAT command and etc.
  - ◆ Continuous playback timing by START command
    - [ ] When making continuous playbacks, send the START command for the next phrases within the specified time period (tcm) after the NCR of the corresponding channel changes to "H" level.
    - [ ] When the playback is not continuous, input the START command for the next phrases after confirming the playback is completed by RDSTAT command, etc.
  - ◆ Continuous playback timing by MUON command
    - [ ] When making continuous playbacks, input the MUON/PLAY/START command for the next phrases within 10ms (tcm) after the NCR of the corresponding channel changes to "H" level. When the playback is not continuous, input the MUON/PLAY/START command for the next phrases after confirming the playback is completed by RDSTAT command and etc.
  - ◆ Repeat playback setting/release timing by SLOOP/CLOOP command
    - [ ] The SLOOP command is valid only during playback. After the PLAY command is input, input the SLOOP command within the specified period (tcm) after the NCR of the corresponding channel becomes "H" level.
- Command
  - Command list
    - [ ] Do not enter command that is not described in this manual. Enter the command with the CBUSYB "H".
  - Description of Command Functions
    - ◆ PUP command
      - [ ] Even if two-times input modes are used for the I2C interface, one-time input is used for the slave address input. If the slave address matches, ACK is returned. If the slave address does not match, NACK is returned. The command is input two-times.

## ◆AMODE command

- [ ] To perform power-down under a setting condition that differs from the power-up condition of the analog unit, set the AMODE command to set the power-down condition again.
- [ ] To power up the analog part, set the CVOL command to 00h (initial value) and then enter the AMODE command.
- [ ] When using analog mixing from the AIN pin, set DAMP = "0" (Class AB amplifier is used). In this LSI, select DAMP = "0" (Class AB amplifier is used).
- [ ] Input the sound signals to the AIN pin after CBUSYB pin becomes "H" by the AMODE command.
- [ ] When using a Class D amplifier with speaker amplifier outputs, set it to the power-up state (AEN1/AEN0= "01") or the power-down state (AEN1/AEN0= "00"). If DAMP = "1" is selected, do not set AEN1= "1".

## ◆AVOL command

- [ ] AV5-AV2=1h and 2h are prohibited.

## ◆FDIRECT command

- [ ] The FDIRECT command controls accesses to the flash memory using the clock synchronous serial interface. Input the command after inputting the PUP command.
- [ ] Do not enter this command because this command is ignored when this command is entered from the I<sup>2</sup>C interface.
- [ ] To cancel the flash memory access mode, insert a reset (RESETB = "L") and conduct initialization or turn off the power supply.

## ◆START command

- [ ] Be sure to specify one of the channels for the channel setting (CH0-CH3). Do not input it to "0" (all "0") with specifying nothing. If it is input with specifying nothing (all "0"), the command is ignored.

## ◆STOP command

- [ ] The STOP command can be input regardless of the status of the NCR during playback operation. However, following the elapse of CBUSYB "L" level output time 3 (tCB3), input the next command after confirming that the BUSYB signal becomes "H". If the BUSYB signal does not become "H", enter the STOP command again.
- [ ] Be sure to specify one of the channels for the channel setting (CH0-CH3). Do not input it to "0" (all "0") with specifying nothing. If it is input with specifying nothing (all "0"), the command is ignored.

## ◆MUON command

- [ ] Set the silence setting (M7-M0) to 04h or more (tmu>=20ms).
- [ ] Be sure to specify one of the channels for the channel setting (CH0-CH3). Do not input it to "0" (all "0") with specifying nothing. If it is input with specifying nothing (all "0"), the command is ignored.

## ◆SLOOP command

- [ ] Be sure to specify one of the channels for the channel setting (CH0-CH3). Do not input it to "0" (all "0") with specifying nothing. If it is input with specifying nothing (all "0"), the command is ignored.

## ◆CLOOP command

- [ ] Be sure to specify one of the channels for the channel setting (CH0-CH3). Do not input it to "0" (all "0") with specifying nothing. If it is input with specifying nothing (all "0"), the command is ignored.

## ◆CVOL command

- [ ] Be sure to specify one of the channels for the channel setting (CH0-CH3). When multiple channels are specified, the volume of the specified channels is set. Do not input it to "0" (all "0") with specifying nothing. If it is input with specifying nothing (all "0"), the command is ignored.

## ◆RDSTAT command

- [ ] When reading the status of the second byte after command input, set the SI pin to "L".

## ◆RDVER command

- [ ] When reading the status of the second byte after command input, set the SI pin to "L".

## ◆RDERR command

- [ ] When reading the status of the second byte after command input, set the SI pin to "L".
- [ ] If the outputs of misoperation detection and failure detection are selected by OUTSTAT command, and the read data is all "L" even though STATUS1 or STATUS2 pin is "H", the read data cannot be read normally. Be sure to read it again.

## ◆SAFE command

- [ ] The initial value is the operation stop state ("0"). When this bit is set to "1", operation starts.
- [ ] \*1 Do not set WDTEN and RSTEN to "1" at the same time. If these bits are set to "1" at the same time, only the RSTEN bit is set to "1".



## ◆SAICH command

- [ ] Set these bits when channels other than SAIs are not playing back (BUSYBn is "1").
- [ ] If you want to set LEN="0" and REN="1" with LEN="1" and REN="0", set LEN="0" and REN="1" after setting LEN=REN="0".
- [ ] Start the LRCLK/BCLK input after entering the SAICON command. Subsequently, enter the MUON command and then the SAICH command.
- [ ] After entering the MUON command, enter the SAICH command at least 10ms prior to the end of the silence period set by the MUON command.
- [ ] Use a channel that is not played back by SAICH as the playback channel set by MUON commands. To mix with ROM playback, use a channel for ROM playback.

## ◆SAICON command

- [ ] Set this bit when the Lch-side serial audio interface (SAI) operation of the SAICH command is stopped (LEN="0") and the Rch-side serial audio interface (SAI) operation is stopped (REN="0"). If either LEN or REN is set to "1", the entered SAICON command is ignored.

## ◆SAITCON command

- [ ] Use the same format as that of SAIRCON command. Set this bit when the Lch-side serial audio interface (SAI) operation of the SAICH command is stopped (LEN="0") and the Rch-side serial audio interface (SAI) operation is stopped (REN="0"). If either LEN or REN is set to "1", the entered SAITCON command is ignored.

## ◆SAIRCON command

- [ ] Use the same format as that of SAITCON command. Set this bit when the Lch-side serial audio interface (SAI) operation of the SAICH command is stopped (LEN="0") and the Rch-side serial audio interface (SAI) operation is stopped (REN="0"). If either LEN or REN is set to "1", the entered SAIRCON command is ignored.

## ◆SAIMOD command

- [ ] Set this bit when the Lch-side serial audio interface (SAI) operation of the SAICH command is stopped (LEN="0") and the Rch-side serial audio interface (SAI) operation is stopped (REN="0"). If either LEN or REN is set to "1", the entered SAIMOD command is ignored.

## ■Peripheral circuit

- Handling of SG Pin / ●Handling of  $V_{DDL}$ ,  $V_{DDR}$  Pins / ●Power wiring / ●Bypass capacitor / ●Coupling capacitor

- [ ] Confirm the recommended values and precautions in this chapter.

## ■Package Dimensions

- [ ] Confirm "Notes for heat sink type Package" and "Notes for Mounting the Surface Mount Type Package" in this chapter.

## ■Speech LSI Utility Setting Items

- [ ] Confirm setting items of "Speech LSI Utility" in this chapter.

### ■ Revision history

| Document No.  | Date         | Page   |                       | Description   |
|---------------|--------------|--|-----------------------|---|
|               |              | Previous edition   | Current edition       |   |
| FEDL22Q53X-01 | Apr 24, 2020 | -  | -                     | Formal 1st edition.   |
| FEDL22Q53X-02 | Jun 23, 2020 | 2  | 2                     | Added "DV <sub>DD</sub> , SPV <sub>DD</sub> /SPOV <sub>DD</sub> and IOV <sub>DD</sub> can be set independently. (SPV <sub>DD</sub> =SPOV <sub>DD</sub> ≥DV <sub>DD</sub> )" to the description of power-supply voltage. |
|               |              | 4<br>21<br>172<br>173  | 4<br>21<br>172<br>173 | Changed description of SCL pin to "be sure to insert a pull-up resistor between DV <sub>DD</sub> pin."  |
|               |              | 12   | 12                    | Added "**3" to the standard value of I <sub>DDO</sub> and I <sub>DDS</sub> of DC characteristics.   |
|               |              | 20   | 20                    | Added "Accessing with I <sup>2</sup> C slave interface at the same time is prohibited." to Clock Synchronous Serial Interface.  |
|               |              | 21   | 21                    | Added "Accessing with clock synchronous serial interface at the same time is prohibited." to Clock Synchronous Serial Interface.  |
|               |              | 24   | 24                    | Added description to SAI(Serial Audio Interface).   |
|               |              | 27   | 27                    | Added definition of compression rate.   |
|               |              | 34   | 34                    | Changed description of command error detection. (Not a change in product specifications.)   |
|               |              | 38   | 38                    | Changed description of watchdog timer overflow detection. (Not a change in product specifications.)   |
|               |              | 40   | 40                    | Changed description of RST counter overflow detection. (Not a change in product specifications.)  |
|               |              | 44   | 44                    | Added description of mixing number error detection.   |
|               |              | 46   | 46                    | Added a method to return from flash memory access mode to normal mode.  |
|               |              | 108  | 108                   | Changed description of DAMP bit of AMODE command. (Not a change in product specifications.)   |
|               |              | 109  | 109                   | Changed description of POP bit of AMODE command. (Not a change in product specifications.)  |
|               |              | 109  | 109                   | Changed description of table of AEN1, AEN0 and POP bit, of AMODE command. (Not a change in product specifications.)   |
|               |              | 131  | 131                   | Changed description of OSCEN bit of SAFE command. (Not a change in product specifications.)   |
|               |              | 163  | 163                   | Added attention of voltage setting of SPV <sub>DD</sub> /SPOV <sub>DD</sub> and DV <sub>DD</sub> for power wiring.  |
| 163           | 163          | Added C12 to the coupling capacitor.   |                       |   |
| 166           | 166          | Changed notation of recommended ceramic resonator. (Not a recommended product change.) |                       |   |

Notes

- 1) The information contained herein is subject to change without notice.
- 2) Although LAPIS Semiconductor is continuously working to improve product reliability and quality, semiconductors can failure and malfunction due to various factors. Therefore, in order to prevent personal injury or fire arising from failure, please take safety measures such as complying with the derating characteristics, implementing redundant and fire prevention designs, and utilizing backups and fail-safe procedures. LAPIS Semiconductor shall have no responsibility for any damages arising out of the use of our Products beyond the rating specified by LAPIS Semiconductor.
- 3) Examples of application circuits, circuit constants and any other information contained herein are provided only to illustrate the standard usage and operations of the Products. The peripheral conditions must be taken into account when designing circuits for mass production.
- 4) The technical information specified herein is intended only to show the typical functions of the Products and examples of application circuits for the Products. No license, expressly or implied, is granted hereby under any intellectual property rights or other rights of LAPIS Semiconductor or any third party with respect to the information contained in this document; therefore LAPIS Semiconductor shall have no responsibility whatsoever for any dispute, concerning such rights owned by third parties, arising out of the use of such technical information.
- 5) The Products are intended for use in general electronic equipment (i.e. AV/OA devices, communication, consumer systems, gaming/entertainment sets) as well as the applications indicated in this document.
- 6) The Products specified in this document are not designed to be radiation tolerant.
- 7) For use of our Products in applications requiring a high degree of reliability (as exemplified below), please contact and consult with a LAPIS Semiconductor representative: transportation equipment (i.e. cars, ships, trains), primary communication equipment, traffic lights, fire/crime prevention, safety equipment, medical systems, servers, solar cells, and power transmission systems.
- 8) Do not use our Products in applications requiring extremely high reliability, such as aerospace equipment, nuclear power control systems, and submarine repeaters.
- 9) LAPIS Semiconductor shall have no responsibility for any damages or injury arising from non-compliance with the recommended usage conditions and specifications contained herein.
- 10) LAPIS Semiconductor has used reasonable care to ensure the accuracy of the information contained in this document. However, LAPIS Semiconductor does not warrant that such information is error-free and LAPIS Semiconductor shall have no responsibility for any damages arising from any inaccuracy or misprint of such information.
- 11) Please use the Products in accordance with any applicable environmental laws and regulations, such as the RoHS Directive. For more details, including RoHS compatibility, please contact a ROHM sales office. LAPIS Semiconductor shall have no responsibility for any damages or losses resulting non-compliance with any applicable laws or regulations.
- 12) When providing our Products and technologies contained in this document to other countries, you must abide by the procedures and provisions stipulated in all applicable export laws and regulations, including without limitation the US Export Administration Regulations and the Foreign Exchange and Foreign Trade Act.
- 13) This document, in part or in whole, may not be reprinted or reproduced without prior consent of LAPIS Semiconductor.  
Copyright 2019-2020 LAPIS Semiconductor Co., Ltd.

---

**LAPIS Semiconductor Co.,Ltd.**

2-4-8 Shinyokohama, Kouhoku-ku,  
Yokohama 222-8575, Japan  
<http://www.lapis-semi.com/en/>

单击下面可查看定价，库存，交付和生命周期等信息

[>>ROHM Semiconductor \(罗姆\)](#)