

# Octal Bus Transceiver with 3-State Outputs

## FEATURES

- **Power-Supply Range:** 1.65V to 5.5V
- **V<sub>CC</sub> Isolation:** If V<sub>CC</sub> is at GND, Both Ports are in the High-Impedance State
- **I<sub>OFF</sub>:** Supports Partial-Power-Down Mode Operation
- **Extended Temperature:** -40°C to +125°C

## APPLICATIONS

- Handset
- Smartphone
- Tablet
- Desktop PC

## DESCRIPTION

The RS245 is designed for asynchronous communication between two data buses. The logic levels of the direction-control (DIR) input and the output-enable ( $\overline{OE}$ ) input activate either the B-port outputs or the A-port outputs or place both output ports into the high-impedance mode. The device transmits data from the A bus to the B bus when the B-port outputs are activated, and from the B bus to the A bus when the A-port outputs are activated. The input circuitry on both A and B ports is always active and must have a logic HIGH or LOW level applied to prevent excess I<sub>CC</sub> and I<sub>CCZ</sub>.

This device is fully specified for partial-power-down applications using I<sub>OFF</sub>. The I<sub>OFF</sub> circuitry disables the outputs, preventing damaging current backflow through the device when it is powered down.

The V<sub>CC</sub> isolation feature ensures that if either V<sub>CC</sub> input is at GND, all outputs are in the high-impedance state.

To ensure the high-impedance state during power up or power down,  $\overline{OE}$  should be tied to V<sub>CC</sub> through a pullup resistor, the minimum value of the resistor is determined by the current-sinking capability of the driver.

It operates over an ambient temperature range of -40°C to +125°C.

### Device Information <sup>(1)</sup>

PART NUMBER	PACKAGE	BODY SIZE (NOM)
RS245	TSSOP20(20)	6.50mm×4.40mm
	SOP20(20)	12.80mm×7.50mm

(1) For all available packages, see the orderable addendum at the end of the data sheet.

## Functional Block Diagram

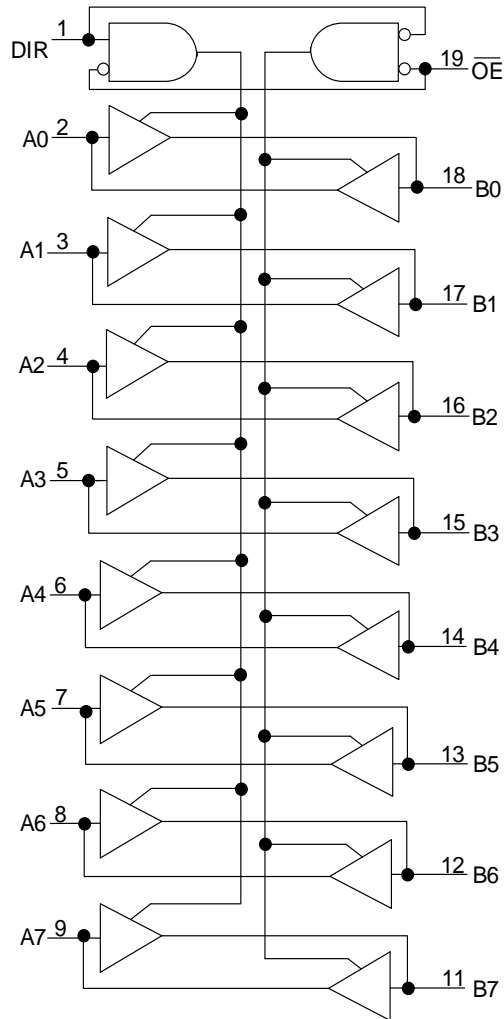

**Function Table**

CONTROL INPUTS		OUTPUT CIRCUITS		OPERATION
$\overline{OE}$	DIR	A PORT	B PORT	
L	L	Enabled	Hi-Z	B data to A bus
L	H	Hi-Z	Enabled	A data to B bus
H	X	Hi-Z	Hi-Z	Isolation

NOTE:  
H=HIGH voltage level  
L=LOW voltage level  
X=don't care  
Z=high impedance OFF-state

## Revision History

Note: Page numbers for previous revisions may differ from page numbers in the current version.

VERSION	Change Date	Change Item
A.1	2021/02/26	Initial version completed
A.2	2021/08/18	1.Fix Switching Characteristics mistake in Page 9、 10@A.1 Version. 2.Fix Application Information mistake in Page 13@A.1 Version.

## PIN CONFIGURATIONS

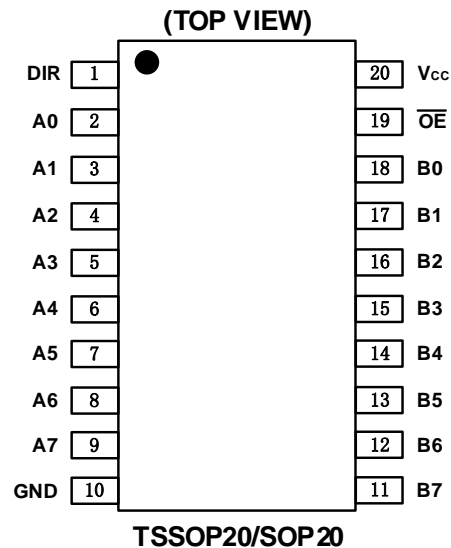

## PIN DESCRIPTION

PIN	NAME	TYPE <sup>(1)</sup>	FUNCTION
TSSOP20/SOP20			
2	A0	I/O	Input/output
3	A1	I/O	Input/output
4	A2	I/O	Input/output
5	A3	I/O	Input/output
6	A4	I/O	Input/output
7	A5	I/O	Input/output
8	A6	I/O	Input/output
9	A7	I/O	Input/output
11	B7	I/O	Input/output
12	B6	I/O	Input/output
13	B5	I/O	Input/output
14	B4	I/O	Input/output
15	B3	I/O	Input/output
16	B2	I/O	Input/output
17	B1	I/O	Input/output
18	B0	I/O	Input/output
1	DIR	I	direction control
10	GND	G	Ground.
19	$\overline{OE}$	I	Output Enable (Active Low). Pull $\overline{OE}$ high to place all outputs in 3-state mode.
20	V <sub>cc</sub>	P	supply voltage. 1.65V ≤ V <sub>cc</sub> ≤ 5.5V

(1) I=input, O=output, I/O=input and output, P=power

## SPECIFICATIONS

### Absolute Maximum Ratings

Over operating free-air temperature range (unless otherwise noted) <sup>(1)</sup>

SYMBOL	PARAMETER		MIN	MAX	UNIT
$V_{CC}$	Supply Voltage Range		-0.5	6.5	V
$V_I^{(2)}$	Input Voltage Range	A port	-0.5	6.5	V
		B port	-0.5	6.5	
		Control inputs	-0.5	6.5	
$V_O^{(2)}$	Voltage range applied to any output in the high-impedance or power-off state	A port	-0.5	6.5	V
		B port	-0.5	6.5	
$V_O^{(2)(3)}$	Voltage range applied to any output in the high or low state	A port	-0.5	$V_{CC}+0.5$	V
		B port	-0.5	$V_{CC}+0.5$	
$I_{IK}$	Input clamp current	$V_I < 0$		-50	mA
$I_{OK}$	Output clamp current	$V_O < 0$		-50	mA
$I_O$	Continuous output current			$\pm 50$	mA
	Continuous current through $V_{CC}$ or GND			$\pm 100$	
$T_J$	Junction Temperature			150	°C
$T_{stg}$	Storage temperature		-65	150	

(1) Stresses beyond those listed under *Absolute Maximum Ratings* may cause permanent damage to the device. These are stress ratings only, which do not imply functional operation of the device at these or any other conditions beyond those indicated under *Recommended Operating Conditions*. Exposure to absolute-maximum-rated conditions for extended periods may affect device reliability.

(2) The input and output negative-voltage ratings may be exceeded if the input and output current ratings are observed.

(3) The value of  $V_{CC}$  are provided in the recommended operating conditions table.

### ESD Ratings

		VALUE	UNIT
$V_{(ESD)}$	Electrostatic discharge	Human-body model (HBM)	$\pm 3000$
		Machine Model (MM)	$\pm 400$

## Recommended Operating Conditions

$V_{CC}$  is the supply voltage associated with the input port and output port.<sup>(1)(2)</sup>

PARAMETER		$V_{CC}$	MIN	TYP	MAX	UNIT
Supply voltage	$V_{CC}$		1.65		5.5	V
High-level input Voltage ( $V_{IH}$ )	Inputs	1.65V to 1.95V	$V_{CC} \times 0.65$			V
		2.3V to 2.7V	1.7			
		3V to 3.6V	2			
		4.5V to 5.5V	$V_{CC} \times 0.7$			
Low-level input Voltage ( $V_{IL}$ )	Inputs	1.65V to 1.95V			$V_{CC} \times 0.35$	V
		2.3V to 2.7V			0.7	
		3V to 3.6V			0.8	
		4.5V to 5.5V			$V_{CC} \times 0.3$	
Input voltage ( $V_I$ )	Input voltage		0		5.5	V
Input/output voltage ( $V_{IO}$ )	Active state		0		$V_{CC}$	V
	3-state		0		5.5	V
High-level output current ( $I_{OH}$ )		1.65V to 1.95V			-4	mA
		2.3V to 2.7V			-8	
		3V to 3.6V			-24	
		4.5V to 5.5V			-32	
Low-level output current ( $I_{OL}$ )		1.65V to 1.95V			4	mA
		2.3V to 2.7V			8	
		3V to 3.6V			24	
		4.5V to 5.5V			32	
Input transition rise or fall rate ( $\Delta t/\Delta v$ )	Data inputs	1.65V to 1.95V			20	ns/V
		2.3V to 2.7V			20	
		3V to 3.6V			10	
		4.5V to 5.5V			5	
$T_A$ Operating free-air temperature			-40		125	°C

(1) All unused or driven (floating) data inputs (I/Os) of the device must be held at logic HIGH or LOW (preferably  $V_{CC}$  or GND) to ensure proper device operation and minimize power.

(2) All unused control inputs must be held at  $V_{CC}$  or GND to ensure proper device operation and minimize power consumption.

(3) For  $V_{CC}$  values not specified in the data sheet,  $V_{IH} \text{ min} = V_{CC} \times 0.7 \text{ V}$ ,  $V_{IL} \text{ max} = V_{CC} \times 0.3 \text{ V}$ .

**PACKAGE/ORDERING INFORMATION**

PRODUCT	ORDERING NUMBER	TEMPERATURE RANGE	PACKAGE LEAD	PACKAGE MARKING <sup>(1)</sup>	MSL <sup>(2)</sup>	PACKAGE OPTION
RS245	RS245YTSS20	-40°C ~+125°C	TSSOP20	RS245	MSL3	Tape and Reel,4000
	RS245YS20	-40°C ~+125°C	SOP20	RS245	MSL3	Tape and Reel,1500

## NOTE:

- (1) There may be additional marking, which relates to the lot trace code information(data code and vendor code), the logo or the environmental category on the device.
- (2) MSL, The Moisture Sensitivity Level rating according to the JEDEC industry standard classifications.

## Electrical Characteristics

over recommended operating free-air temperature range (unless otherwise noted) <sup>(1)</sup> <sup>(2)</sup> <sup>(3)</sup>

PARAMETER		CONDITIONS	V <sub>CC</sub>	TEMP	MIN	TYP	MAX	UNIT
V <sub>OH</sub>		I <sub>OH</sub> = -100 μA V <sub>I</sub> = V <sub>IH</sub>	1.65V to 4.5V	Full	V <sub>CC</sub> - 0.1			V
		I <sub>OH</sub> = -4mA V <sub>I</sub> = V <sub>IH</sub>	1.65V		1.2			
		I <sub>OH</sub> = -8mA V <sub>I</sub> = V <sub>IH</sub>	2.3V		1.9			
		I <sub>OH</sub> = -24mA V <sub>I</sub> = V <sub>IH</sub>	3V		2.4			
		I <sub>OH</sub> = -32mA V <sub>I</sub> = V <sub>IH</sub>	4.5V		3.8			
V <sub>OL</sub>		I <sub>OL</sub> = 100 μA V <sub>I</sub> = V <sub>IL</sub>	1.65V to 4.5V				0.1	V
		I <sub>OL</sub> = 4mA V <sub>I</sub> = V <sub>IL</sub>	1.65V				0.45	
		I <sub>OL</sub> = 8mA V <sub>I</sub> = V <sub>IL</sub>	2.3V				0.3	
		I <sub>OL</sub> = 24mA V <sub>I</sub> = V <sub>IL</sub>	3V				0.55	
		I <sub>OL</sub> = 32mA V <sub>I</sub> = V <sub>IL</sub>	4.5V				0.55	
I <sub>I</sub>	DIR	V <sub>I</sub> = V <sub>CC</sub> or GND	1.65V to 5.5V	+25°C			±1	μA
				Full			±2	
I <sub>off</sub>	A or B Port	V <sub>I</sub> or V <sub>O</sub> = 0 to 5.5V	0V	+25°C			±1	μA
I <sub>oz</sub>	A or B Port	V <sub>O</sub> = V <sub>CC</sub> or GND, OE = V <sub>IH</sub>	1.65V to 5.5V	+25°C			±1	μA
				Full			±2	
I <sub>CC</sub>	V <sub>CC</sub> supply current	V <sub>I</sub> = V <sub>CC</sub> or GND I <sub>O</sub> = 0	1.65V to 5.5V	+25°C			1	μA
				Full			5	
				0V	Full			
ΔI <sub>CC</sub>	A port	One A port at V <sub>CC</sub> - 0.6 V, DIR at V <sub>CC</sub> , B port = open	3V to 5.5V	Full			50	μA
	B port	One B port at V <sub>CC</sub> - 0.6 V, DIR at GND, A port = open		Full			50	μA
	DIR	DIR at V <sub>CC</sub> - 0.6 V, B port = open A port at V <sub>CC</sub> or GND		Full			50	μA
C <sub>I</sub>	Control inputs	V <sub>I</sub> = V <sub>CC</sub> or GND	3.3V	+25°C		4		pF
C <sub>IO</sub>	A port		3.3V	+25°C		8.5		pF
	B port		3.3V	+25°C		8.5		



## Switching Characteristics

PARAMETER	FROM (INPUT)	TO (OUTPUT)	$V_{CC}=1.8V \pm 0.15V$		$V_{CC}=2.5V \pm 0.2V$		$V_{CC}=3.3V \pm 0.3V$		$V_{CC}=5V \pm 0.5V$		UNIT
			MIN	MAX	MIN	MAX	MIN	MAX	MIN	MAX	
$t_{PLH}$	An	Bn	1.7	21.6	1.3	9.1	1.0	7.4	0.8	7.1	ns
$t_{PHL}$											
$t_{PLH}$	Bn	An	0.9	23.5	0.8	23.6	0.7	23.3	0.7	23.3	ns
$t_{PHL}$											
$t_{PHZ}$	$\overline{OE}$	An	1.5	29.5	1.5	29.4	1.5	29.3	1.4	29.1	ns
$t_{PLZ}$											
$t_{PHZ}$	$\overline{OE}$	Bn	2.4	32.2	1.9	12.9	1.7	12.0	1.3	10.2	ns
$t_{PLZ}$											
$t_{PZH}$	$\overline{OE}$	An	0.4	23.8	0.4	23.7	0.4	23.7	0.4	23.7	ns
$t_{PZL}$											
$t_{PZH}$	$\overline{OE}$	Bn	1.8	31.9	1.5	16	1.2	12.6	0.9	10.8	ns
$t_{PZL}$											

## Operating Characteristics

 $T_A=25^\circ C$ 

PARAMETER		TEST CONDITIONS	$V_{CC}=1.8V$	$V_{CC}=2.5V$	$V_{CC}=3.3V$	$V_{CC}=5V$	UNIT
			TYP	TYP	TYP	TYP	
$C_{pd}^{(1)}$	A-port input, B-port output	$C_L=0$ , $f=10MHz$ , $t_r=t_f=1ns$	2	2	2	3	pF
	B-port input, A-port output		42	42	43	44	

(1) Power dissipation capacitance per transceiver

## Typical Characteristics

At  $T_A = +25^\circ\text{C}$ ,  $V_{CC}=5\text{V}$ , unless otherwise noted.

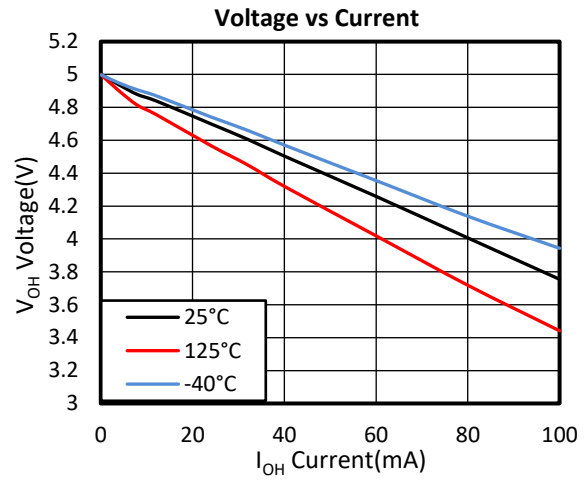
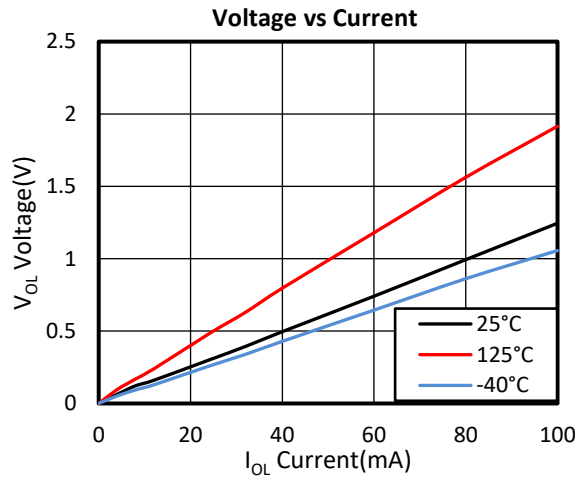

## Parameter Measurement Information

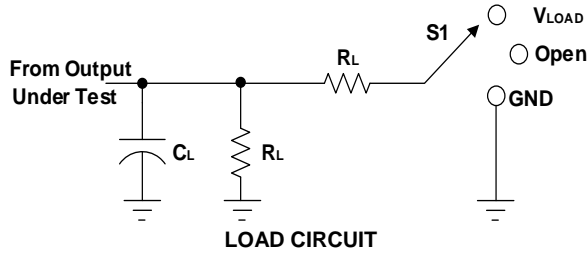

TEST	S1
$t_{pd}$	Open
$t_{PLZ}/t_{PZL}$	$V_{LOAD}$
$t_{PHZ}/t_{PZH}$	GND

$V_{CC}$	$V_I$	$V_M$	$C_L$	$R_L$	$V_{TP}$
$1.8V \pm 0.15V$	$V_{CC}$	$V_{CC}/2$	15pF	2k $\Omega$	0.15V
$2.5V \pm 0.2V$	$V_{CC}$	$V_{CC}/2$	15pF	2k $\Omega$	0.15V
$3.3V \pm 0.3V$	2.7V	1.5V	15pF	2k $\Omega$	0.3V
$5V \pm 0.5V$	2.7V	1.5V	15pF	2k $\Omega$	0.3V

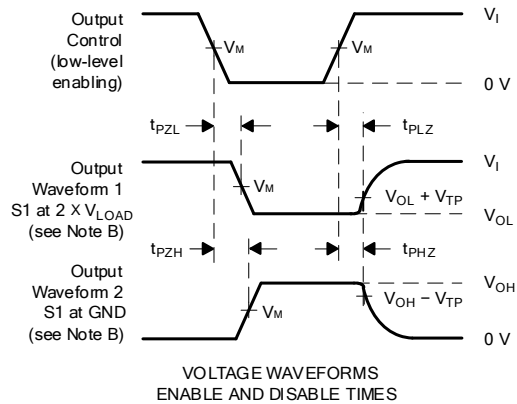
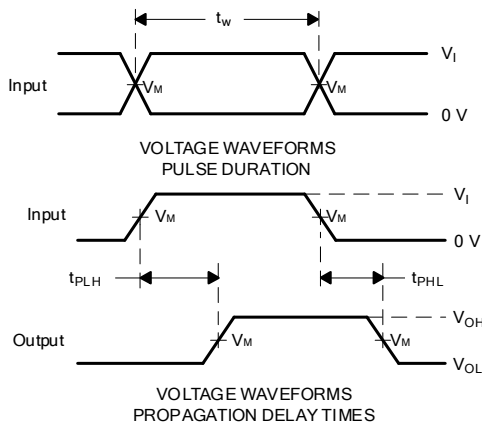

NOTES: A.  $C_L$  includes probe and jig capacitance.

B. Waveform 1 is for an output with internal conditions such that the output is low, except when disabled by the output control.

Waveform 2 is for an output with internal conditions such that the output is high, except when disabled by the output control.

C. All input pulses are supplied by generators having the following characteristics:  $PRR \leq 10$  MHz,  $Z_O = 50 \Omega$ ,  $dv/dt \geq 1V/ns$ .

D. The outputs are measured one at a time, with one transition per measurement.

E.  $t_{PLZ}$  and  $t_{PHZ}$  are the same as  $t_{dis}$ .

F.  $t_{PZL}$  and  $t_{PZH}$  are the same as  $t_{en}$ .

G.  $t_{PLH}$  and  $t_{PHL}$  are the same as  $t_{pd}$ .

H. All parameters and waveforms are not applicable to all devices.

**Figure 1. Load Circuit and Voltage Waveforms**

## Application Information

RS245 is a high drive CMOS device that can be used for a multitude of bus interface type applications where output drive or PCB trace length is a concern. The inputs can accept voltages to 5.5 V at any valid  $V_{CC}$  making it ideal for down translation.

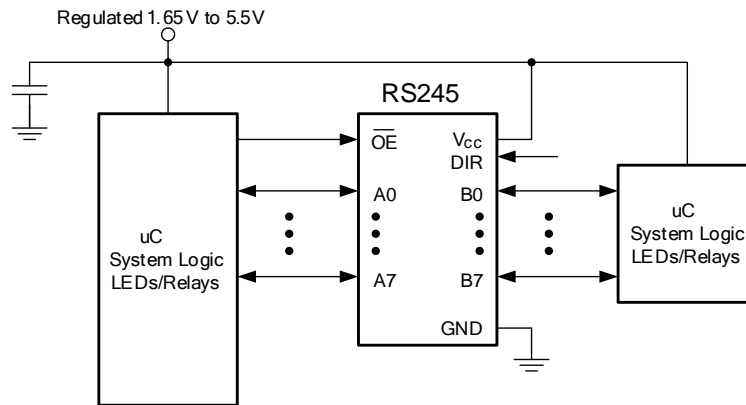

**Figure 2. Typical Application Schematic**

# PACKAGE OUTLINE DIMENSIONS

## TSSOP20

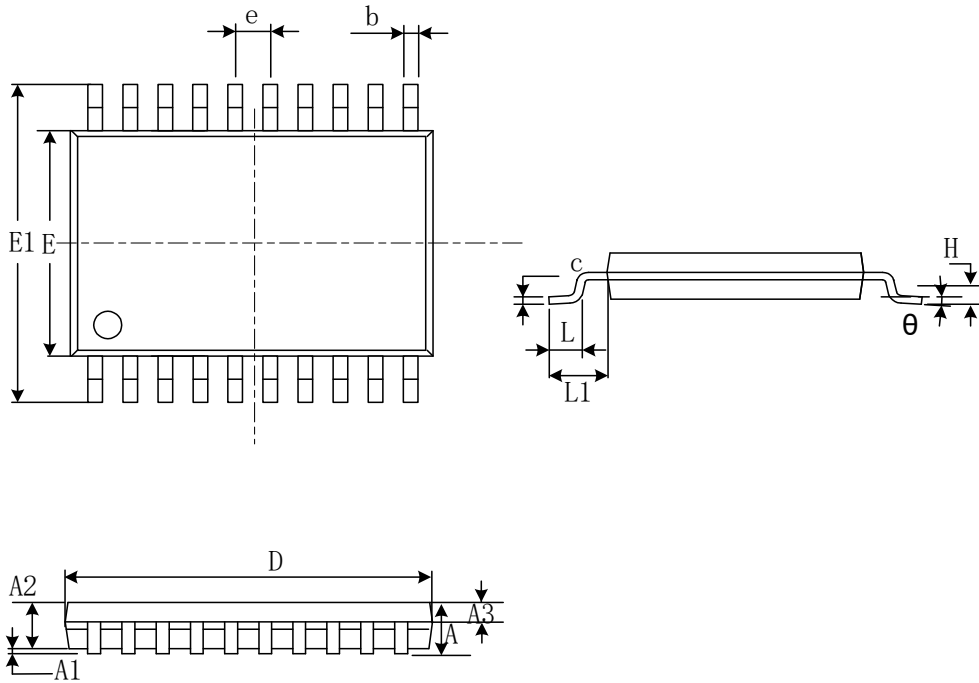

Symbol	Dimensions In Millimeters		Dimensions In Inches	
	Min	Max	Min	Max
A		1.200		0.047
A1	0.050	0.150	0.002	0.006
A2	0.800	1.050	0.031	0.041
A3	0.390	0.490	0.015	0.020
b	0.200	0.290	0.008	0.011
c	0.130	0.170	0.005	0.007
D	6.400	6.600	0.252	0.260
E	4.300	4.500	0.169	0.177
E1	6.200	6.600	0.244	0.260
e	0.650(BSC)		0.026(BSC)	
L	0.450	0.750	0.018	0.030
H	0.250(TYP)		0.010(TYP)	
$\theta$	0°	8°	0°	8°
L1	1.00(REF)		0.039(REF)	

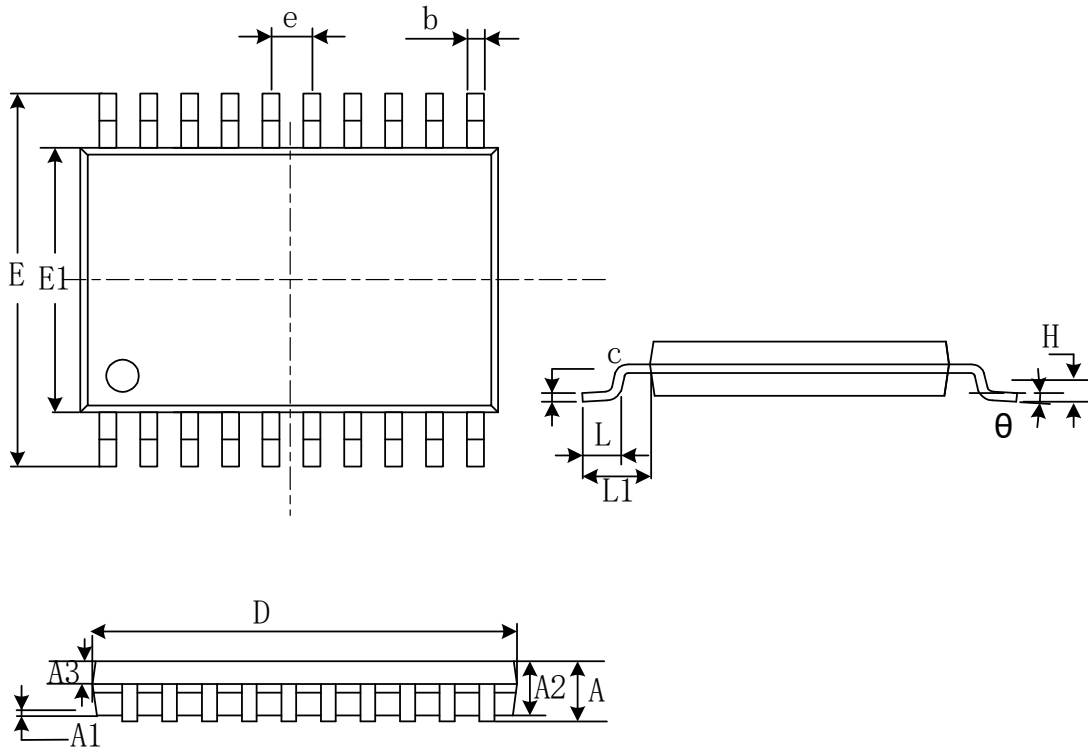
**SOP20**

Symbol	Dimensions In Millimeters		Dimensions In Inches	
	Min	Max	Min	Max
A		2.650		0.104
A1	0.100	0.300	0.004	0.012
A2	2.250	2.350	0.089	0.093
A3	0.970	1.070	0.038	0.042
b	0.390	0.470	0.015	0.019
c	0.250	0.290	0.010	0.011
D	12.700	12.900	0.500	0.508
E	10.100	10.500	0.398	0.413
E1	7.400	7.600	0.291	0.299
e	1.270(BSC)		0.050(BSC)	
L	0.700	1.000	0.028	0.039
H	0.250(TYP)		0.010(TYP)	
θ	0°	8°	0°	8°
L1	1.400(REF)		0.055(REF)	

## TAPE AND REEL INFORMATION

### REEL DIMENSIONS

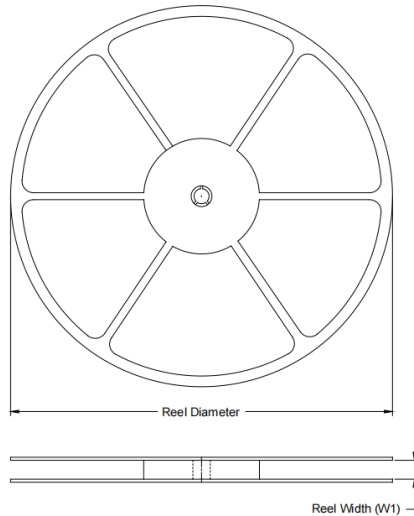

### TAPE DIMENSION

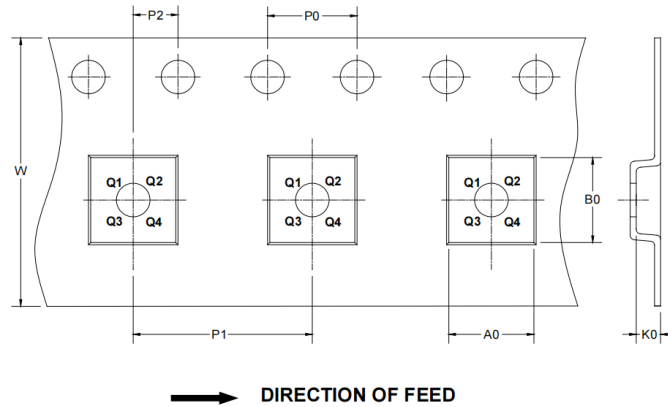

NOTE: The picture is only for reference. Please make the object as the standard.

### KEY PARAMETER LIST OF TAPE AND REEL

Package Type	Reel Diameter	Reel Width (mm)	A0 (mm)	B0 (mm)	K0 (mm)	P0 (mm)	P1 (mm)	P2 (mm)	W (mm)	Pin1 Quadrant
TSSOP20	13"	12.4	6.75	6.95	1.20	4.0	8.0	2.0	12.0	Q1
SOP20	13"	24.4	10.75	13.55	2.65	4.0	12.0	2.0	24.0	Q1

单击下面可查看定价，库存，交付和生命周期等信息

[>>Runic\(润石\)](#)