



Dual N-Channel Enhancement Mode Field Effect Transistor

PRODUCT SUMMARY		
V _{SSS}	I _S	R _{SS(ON)} (mΩ) Max
24V	6A	45.0 @ V _{GS} =4.5V
		48.0 @ V _{GS} =4.0V
		57.0 @ V _{GS} =3.1V
		70.0 @ V _{GS} =2.5V

FEATURES

- Super high dense cell design for low R_{DS(ON)}.
- Rugged and reliable.
- Wafer level CSP.
- ESD Protected.

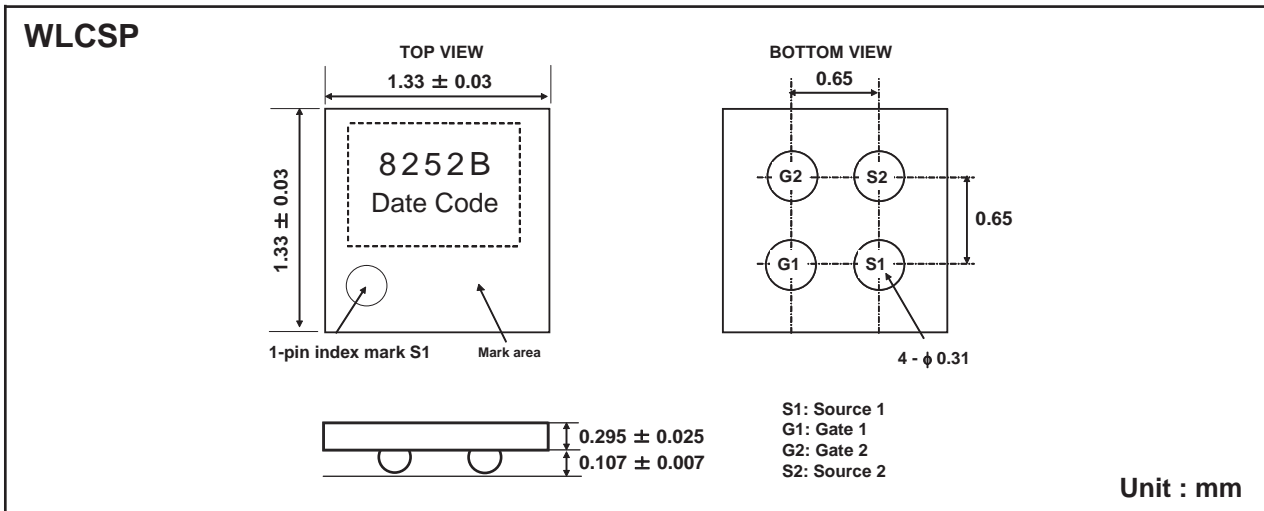

ABSOLUTE MAXIMUM RATINGS (T_A=25°C)

Symbol	Parameter	Limit	Units
V _{SSS}	Source-Source Voltage	24	V
V _{GSS}	Gate-Source Voltage	±12	V
I _S	Source Current-Continuous ^a	6	A
I _{SP}	-Pulsed ^b	60	A
P _T	Total Power Dissipation ^a	1.6	W
T _J , T _{STG}	Operating Junction and Storage Temperature Range	-55 to 150	°C

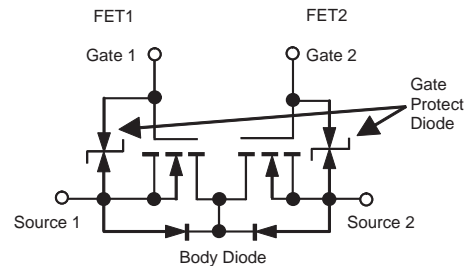

SC8252B

Ver 4.1

ELECTRICAL CHARACTERISTICS (T_A=25°C unless otherwise noted)

Symbol	Parameter	Conditions	Min	Typ	Max	Units
OFF CHARACTERISTICS						
BV _{SSS}	Source-Source Breakdown Voltage	V _{GS} =0V, I _S =250uA	24			V
I _{SSS}	Zero Gate Voltage Source Current	V _{SS} =24V, V _{GS} =0V			1	uA
I _{GSS}	Gate-Body Leakage Current	V _{GS} = ±12V, V _{SS} =0V			±10	uA
ON CHARACTERISTICS						
V _{GS(th)}	Gate Threshold Voltage	V _{SS} =V _{GS} , I _S =1mA	0.5	0.8	1.5	V
R _{SS(ON)}	Source-Source On-State Resistance	V _{GS} =4.5V, I _S =3A	29	39	45	m ohm
		V _{GS} =4.0V, I _S =3A	30	41	48	m ohm
		V _{GS} =3.1V, I _S =3A	36	48	57	m ohm
		V _{GS} =2.5V, I _S =3A	42	58	70	m ohm
g _{FS}	Forward Transconductance	V _{SS} =5V, I _S =3A		16		S
DYNAMIC CHARACTERISTICS ^c						
C _{ISS}	Input Capacitance	V _{SS} =10V, V _{GS} =0V f=1.0MHz		254		pF
C _{OSS}	Output Capacitance			126		pF
C _{RSS}	Reverse Transfer Capacitance			47		pF
SWITCHING CHARACTERISTICS ^c						
t _{D(ON)}	Turn-On Delay Time	V _{DD} =20V I _S =3A		151		ns
t _r	Rise Time			494		ns
t _{D(OFF)}	Turn-Off Delay Time	V _{GS} =4.0V R _{GEN} =6 ohm		1477		ns
t _f	Fall Time			812		ns
Q _g	Total Gate Charge	V _{DD} =20V, I _S =6A, V _{G1S1} =4.0V		7.9		nC
DRAIN-SOURCE DIODE CHARACTERISTICS AND MAXIMUM RATINGS						
V _{FSS}	Diode Forward Voltage	V _{GS} =0V, I _S =1.5A		0.81	1.2	V
Note a. Mounted on FR4 board of 25.4mm x 25.4mm x 1.6mm. b. Pulse Test: Pulse Width < 10us, Duty Cycle < 1%. c. Guaranteed by design, not subject to production testing.						

Mar,03,2017

V_{SSS} / I_{SSS}

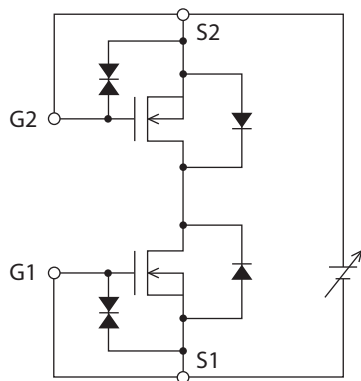

$I_{GSS} (+) / (-)$

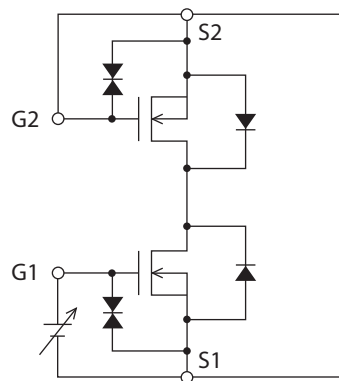

$V_{GS} \text{ (off)}$

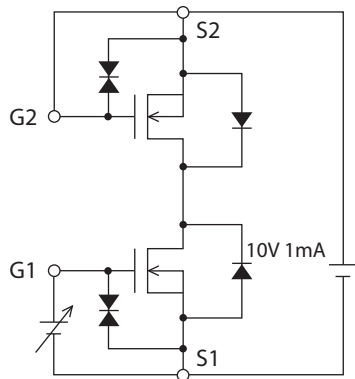

$|y_{fs}|$

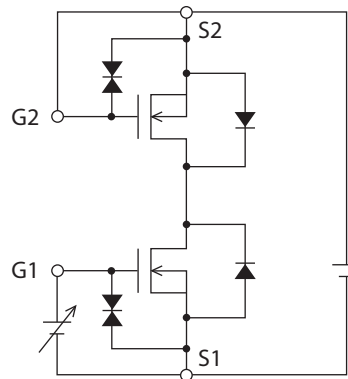

* Note: Connect the measurement terminal reversely if you want to measure the FET2 side.

SC8252B

Ver 4.1

$R_{SS}(\text{on})$

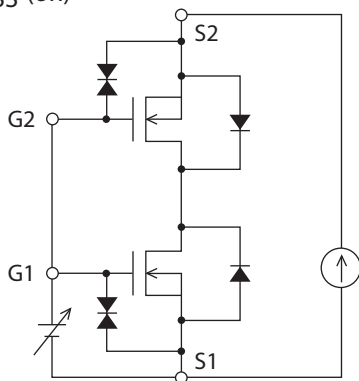

$V_F(\text{S-S})$

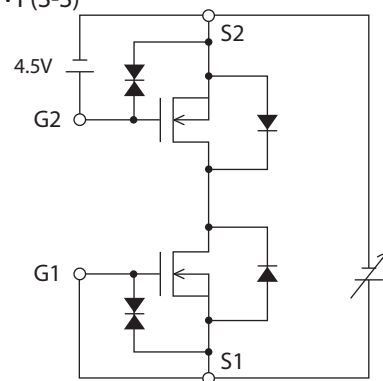

$t_d(\text{on}), t_r, t_d(\text{off}), t_f$

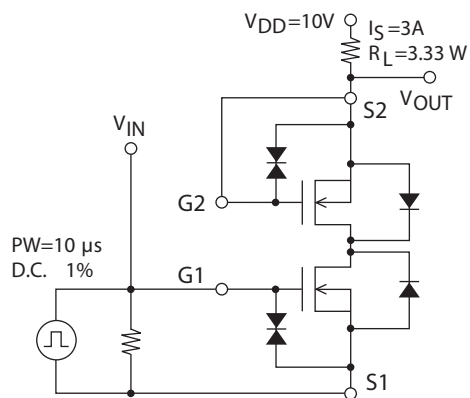

Q_g

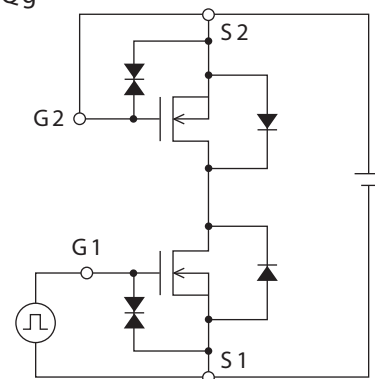

* Note: Connect the measurement terminal reversely if you want to measure the FET2 side.

Mar,03,2017

SC8252B

Ver 4.1

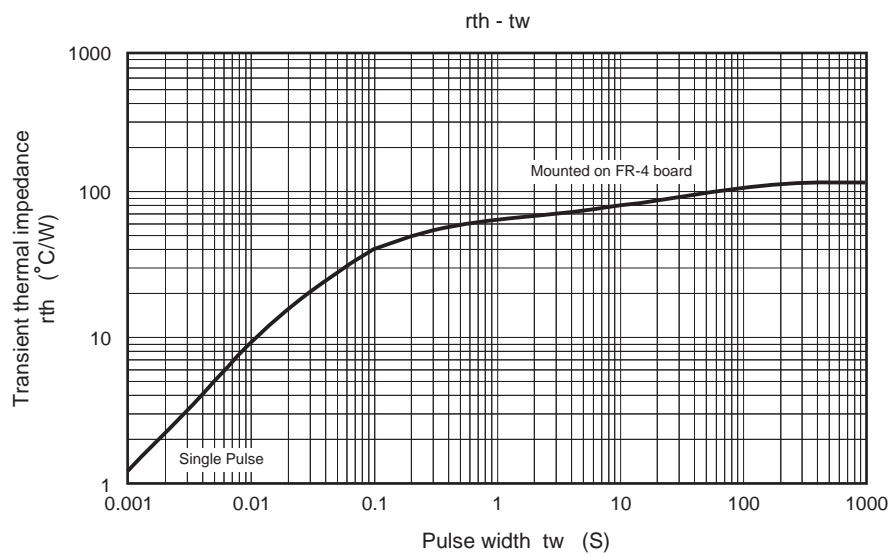
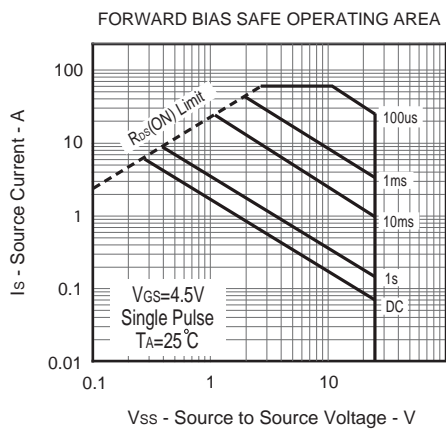
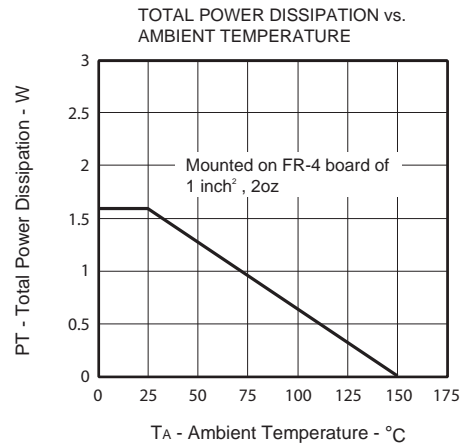
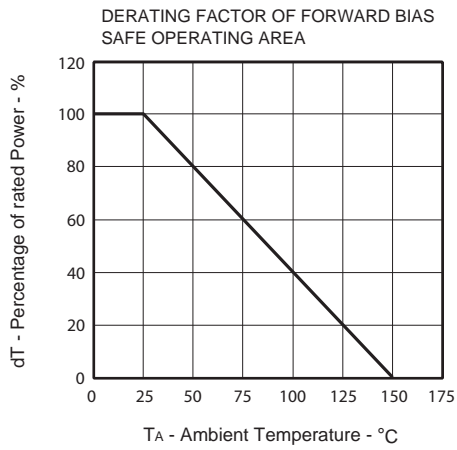

Mar,03,2017

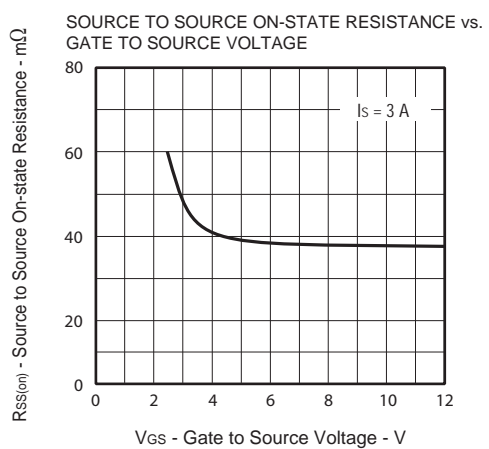
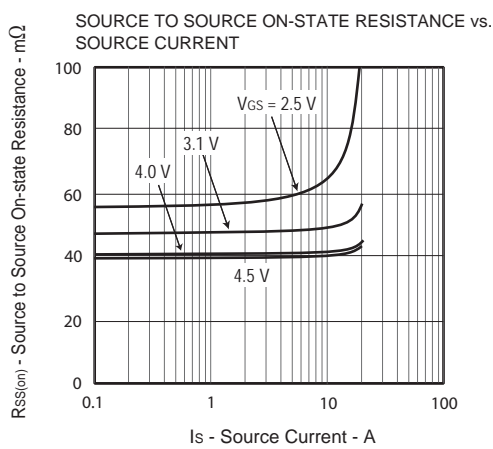
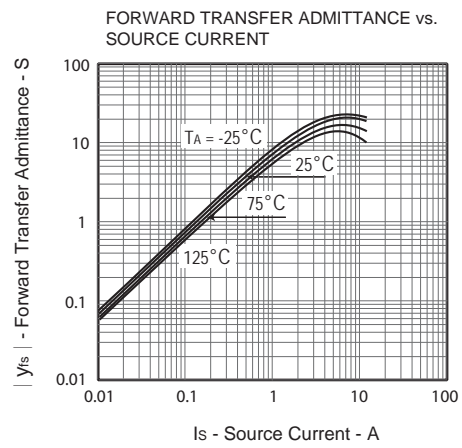
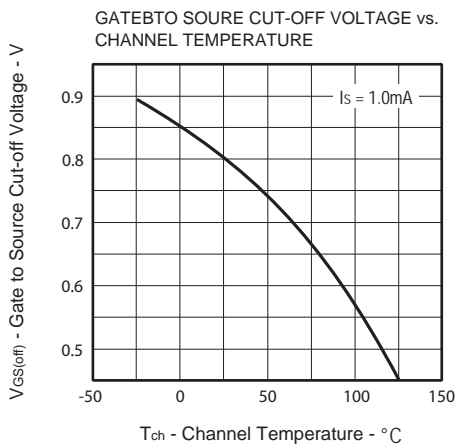
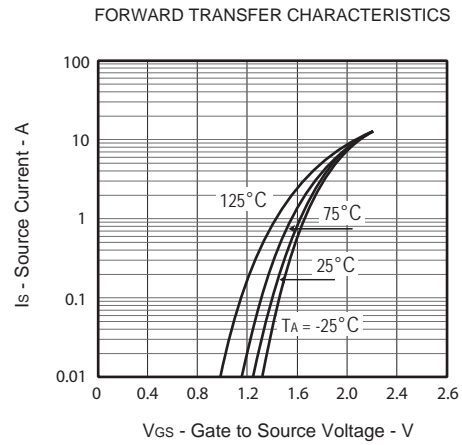
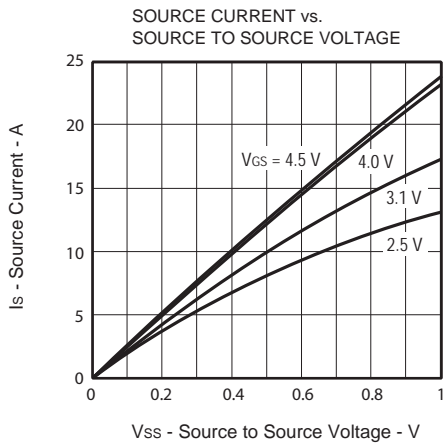

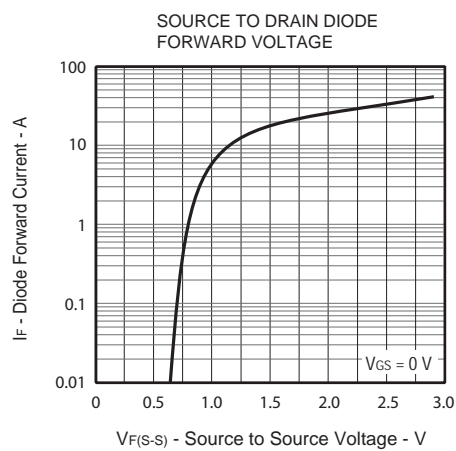
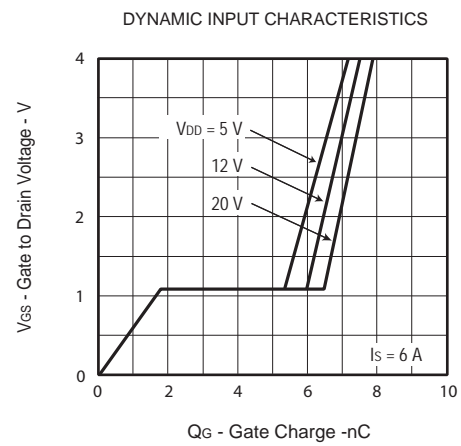
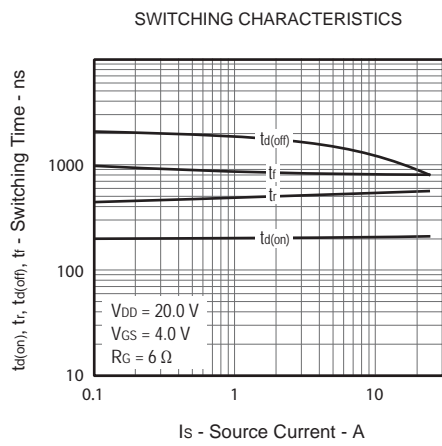
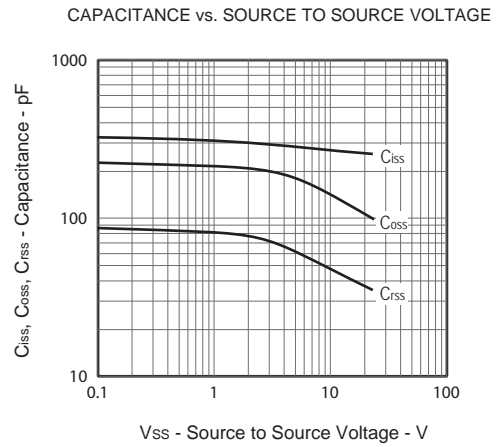
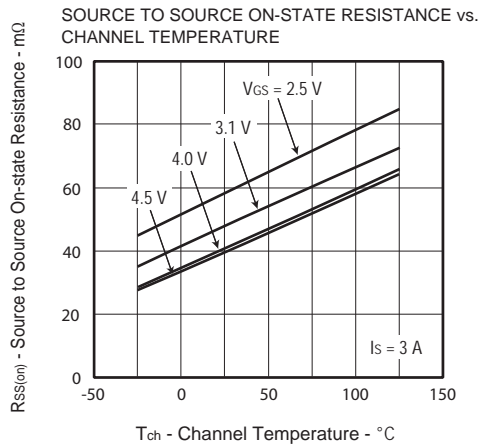

TOP MARKING DEFINITION

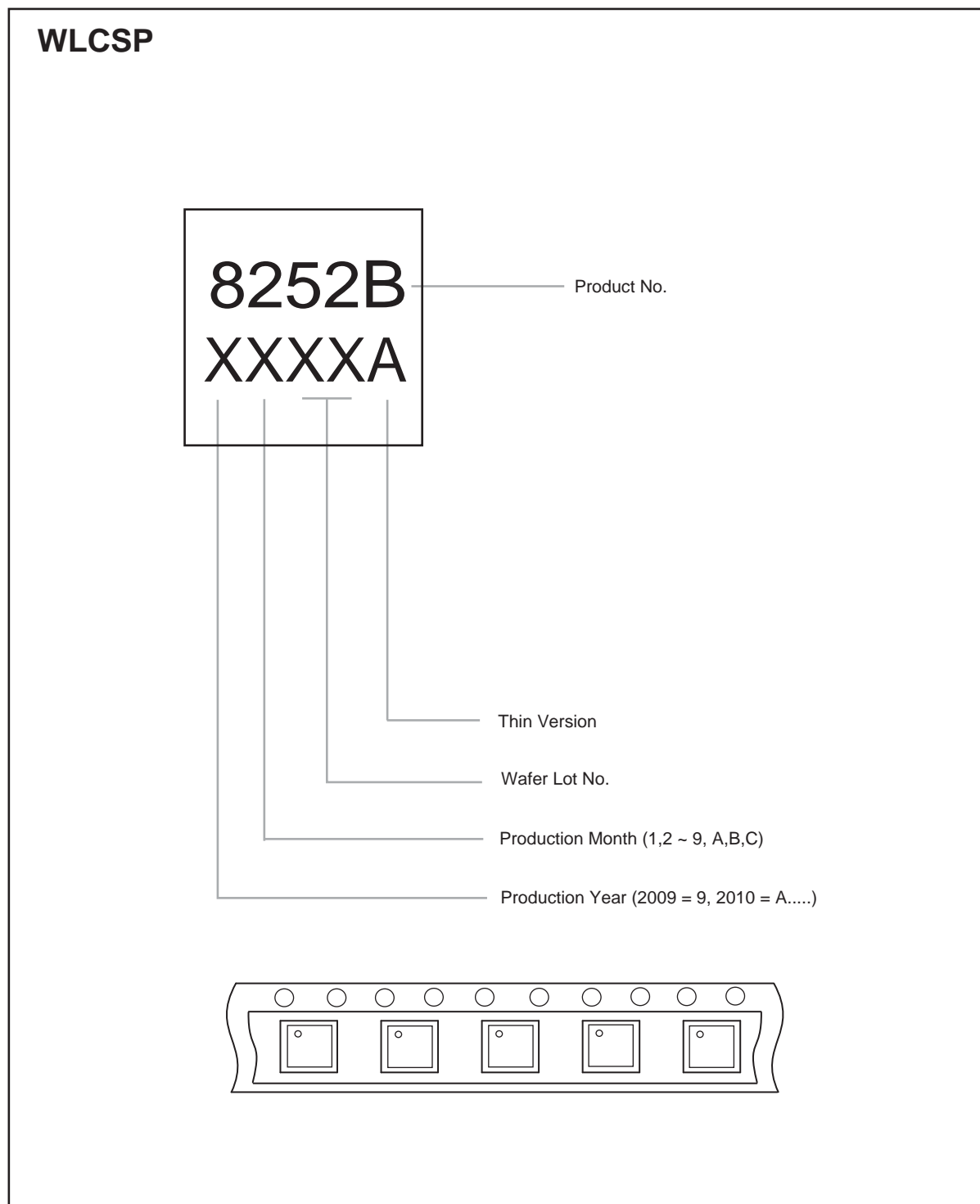

单击下面可查看定价，库存，交付和生命周期等信息

[>>SAMHOP](#)