Self-Adjusting Hall-Effect Gear Tooth Sensor IC

FEATURES

- Zero speed detection
- Insensitive to orientation
- Self-adjusting magnetic range
- Short circuit protection
- 3.0 to 24V supply operating range
- -40°C-150°C operating temperature range
- Output protection against electrical disturbances
- RoHs compliant



DESCRIPTION

The SC9314 is a sophisticated IC featuring an on-chip 10-bit A/D Converter and logic that act as a digital sample and hold circuit. A separate 4-bit D/A converter provides a fixed hysteresis. The SC9314 does not have a chopper delay and uses a single Hall plate which is immune to rotary alignment problems. The bias magnet can be from 100mT to 400mT. As the signal is sampled, the logic recognizes an increasing or decreasing flux density.

The output will turn off (B_{RP}) after the flux has reached its peak and then decreased by an amount equal to the hysteresis. Similarly, the output will turn on (B_{OP}) after the flux has reached its minimum value and then increased by an amount equal to the hysteresis.

The device is available in a 3-pin SIP package and is lead (Pb) free, with 100% matte tin lead frame plating.

CONTENTS

FEATURES	1 -	THERMAL CHARACTERISTICS	5 -
DESCRIPTION	1 -	OPERATING CHARACTERISTICS	6 -
BLOCK DIAGRAM	3 -	FUNCTIONAL DESCRIPTION	7 -
ORDERING INFORMATION	3 -	<i>Gear Tooth Sensing</i>	8 -
TERMINAL CONFIGURATION AND TYPICAL APPLICATION	4 -	PACKAGE INFORMATION	9 -
ABSOLUTE MAXIMUM RATINGS	5 -	REVISION HISTORY	10 -
ESD PROTECTION	5 -		

BLOCK DIAGRAM

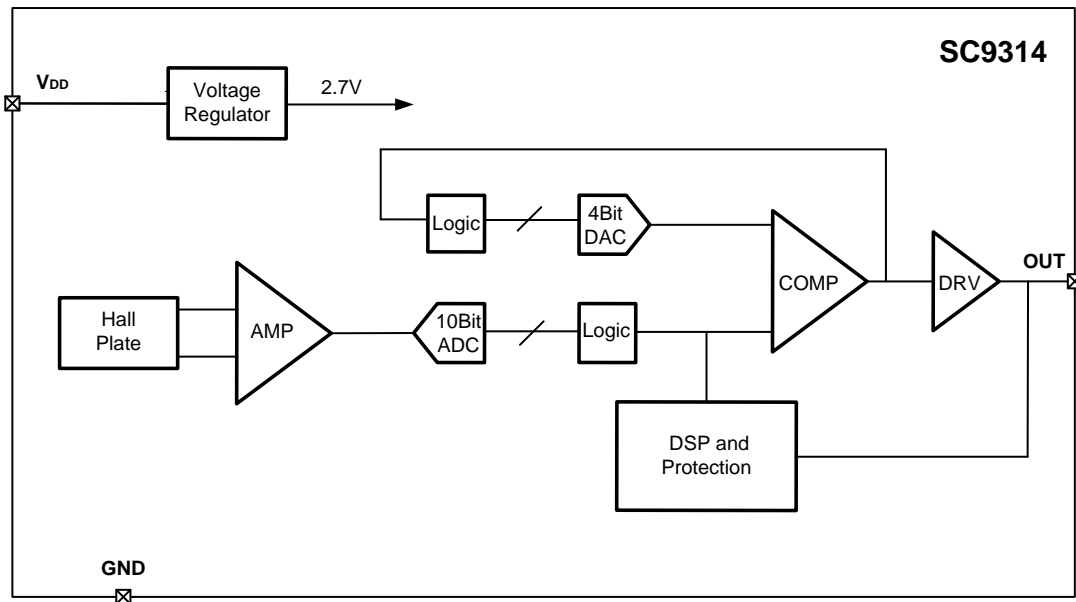

ORDERING INFORMATION

Part Number	Packing	Mounting	Ambient, T _A	Marking
SC9314UA	Bulk, 1000 pieces/bag	3-pin SIP	-40°C to 150°C	94M

TERMINAL CONFIGURATION AND TYPICAL APPLICATION

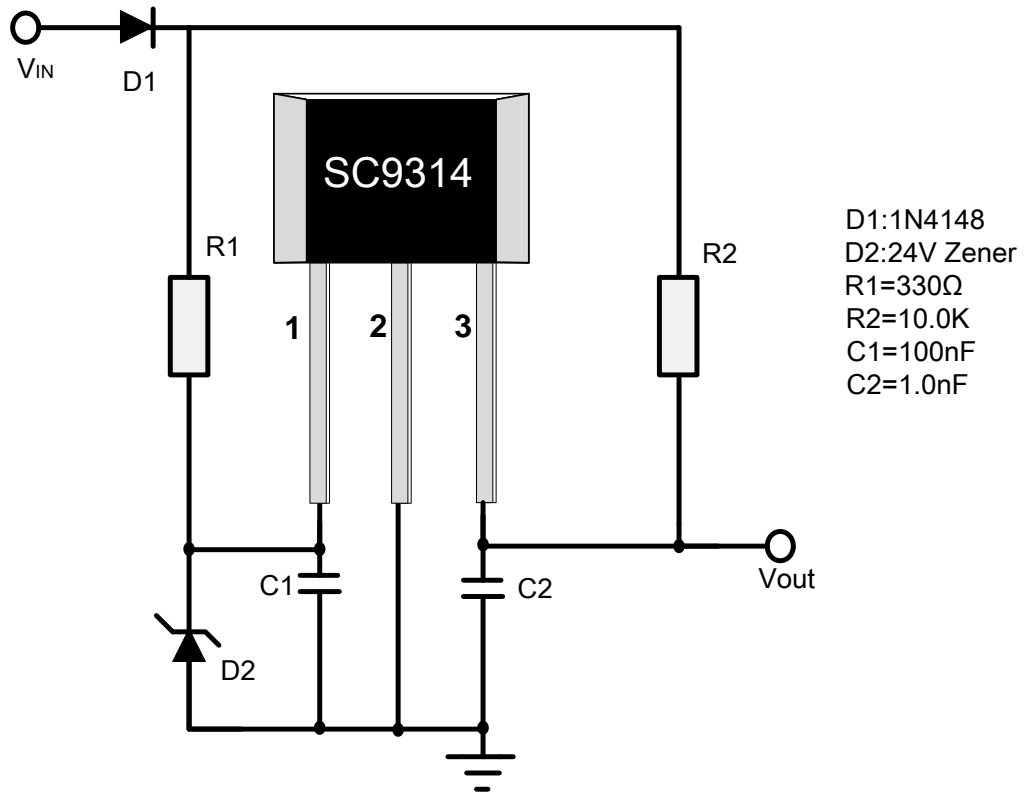

Terminal		Type	Description
Name	Number		
V _{DD}	1	PWR	3.0 V ~ 24 V power supply
GND	2	Ground	Ground
OUT	3	Output	Open-drain output required a pull-up resistor

ABSOLUTE MAXIMUM RATINGS

over operating free-air temperature range

Parameter	Symbol	Min.	Max.	Units
Power supply voltage	V_{DD}	-0.5	30	V
Output terminal voltage	OUT	-0.5	30	V
Output terminal current sink	I_{SINK}	0	30	mA
Operating ambient temperature	T_A	-40	150	°C
Maximum junction temperature	T_J	-55	165	°C
Storage temperature	T_{STG}	-65	175	°C

Note: Stresses above those listed here may cause permanent damage to the device. Exposure to absolute maximum rating conditions for extended periods may affect device reliability.

ESD PROTECTION

Human Body Model (HBM) tests according to: standard AEC-Q100-002

Parameter	Symbol	Min.	Max.	Units
ESD-Protection	V_{ESD}	-8	8	kV

THERMAL CHARACTERISTICS

Symbol	Parameter	Test Conditions	Rating	Units
$R_{\theta JA}$	Package thermal resistance	Single-layer PCB, with copper limited to solder pads	166	°C/W

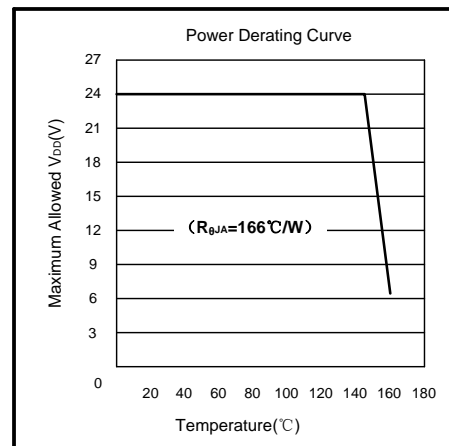
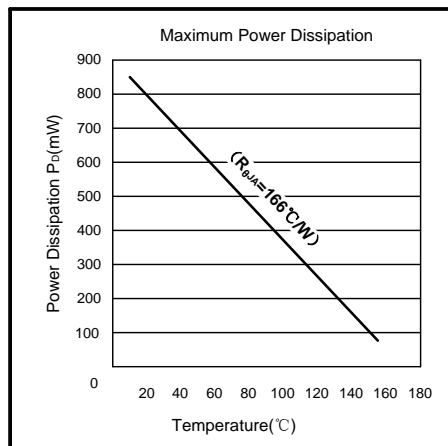

OPERATING CHARACTERISTICS

over operating free-air temperature range ($V_{DD}=12V$, unless otherwise noted)

Symbol	Parameter	Test Conditions	Min.	Typ.	Max.	Units
Electrical parameters						
V_{DD}	Operating voltage	$T_J < T_{J(max)}$	3.0	--	24	V
I_{DD}	Operating supply current	$V_{DD}=3.0V$ to 24 V	1.0	2.0	3.5	mA
V_{Qsat}	Output saturation voltage	$I_o=20mA$, $T_A=25^\circ C$	--	150	400	mV
I_{QL}	Output leakage current	$V_{DD} < 24V$	--	--	10	μA
t_{rp}^1	Response time	$V_{DD}>3.0V$, $f=1kHz$	0	--	50	mS
t_r^2	Output rise time	$R1=1Kohm$ $C_o=20pF$	--	--	0.5	μS
t_f	Output fall time	$R1=1Kohm$ $C_o=20pF$	--	--	0.5	μS
f_{cu}	Upper corner frequency	-3dB, single pole	--	20	--	kHz
f_{cl}	Lower corner frequency	-3dB, single pole	--	0	--	Hz
Magnetic Characteristics						
B_{Back}	Pre-induction		-3	--	300	mT
B_{OP}	Turn on hysteresis	$B_{Back}=300mT$	1.0	2.5	4.0	mT
B_{RP}	Turn off hysteresis	$B_{Back}=300mT$	1.0	2.5	4.0	mT
--	Linear Region	$V_{DD}=3.0V$ to 24 V	50	0	300	mT

$1mT=10Gs$

¹Time required to initialize device.

²Output Rise Time will be dominated by the RC time constant.

FUNCTIONAL DESCRIPTION

In the case of ferromagnetic toothed wheel application, the IC has to be biased by the South pole of a permanent magnet (Typical 300mT). When assembling the sensor system, a magnet as back bias flux from 100mT to 300mT is suggested. Normally the South pole of magnet faces the unbranded side of the IC and the magnet is glued to the back surface (non branded side) of the IC using an adhesive or suitable epoxy. Due to the SC9314's "Self-adjusting" over a wide range of back bias flux, the need for any trimming in the application is eliminated.

At the chip power on state, if the power is raised quickly and the output is reset to the high state whatever the field is. The output will change to low after the flux has reached its minimum value and then increased by an amount equal to the hysteresis. The output will change to high after the flux has reached its peak and then decreased by an amount equal to the hysteresis similarly. However, if the supply is raised slowly, then the reset state is not determined; the output can be either high or low.

It is strongly recommended that an external ceramic bypass capacitor in the range 10nF to 1uF be connected between the supply and ground of the device to reduce external noise. The series resistor in combination with the bypass capacitor creates a filter for EMC pulse.

The pull-up resistor should be chosen to limit the current through the output transistor, without exceeding the maximum continuous output current of the device.

Gear Tooth Sensing

In the case of ferromagnetic toothed wheel application, the IC has to be biased and only biased by the South pole of a permanent magnet which should cover both Hall probes

The maximum air gap depends on

- the magnetic field strength (magnet used; pre-induction), and
- the toothed wheel that is used (dimensions, material, etc.)

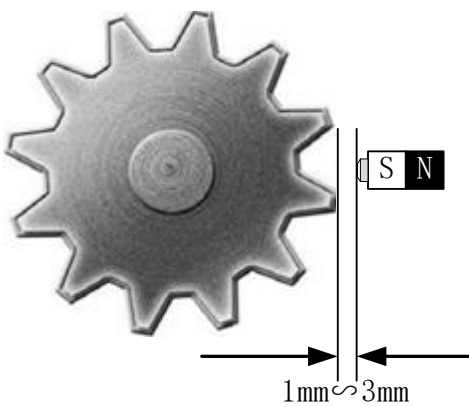

Switch Points v.s. Magnetic Singal

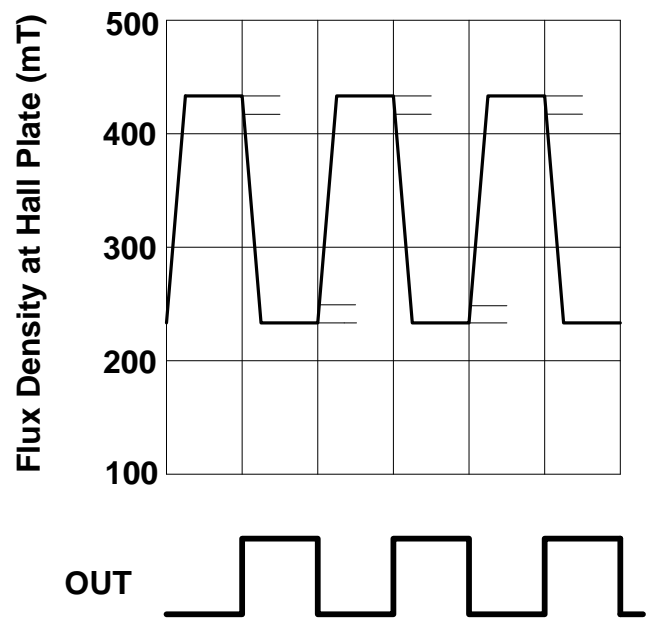

PACKAGE INFORMATION

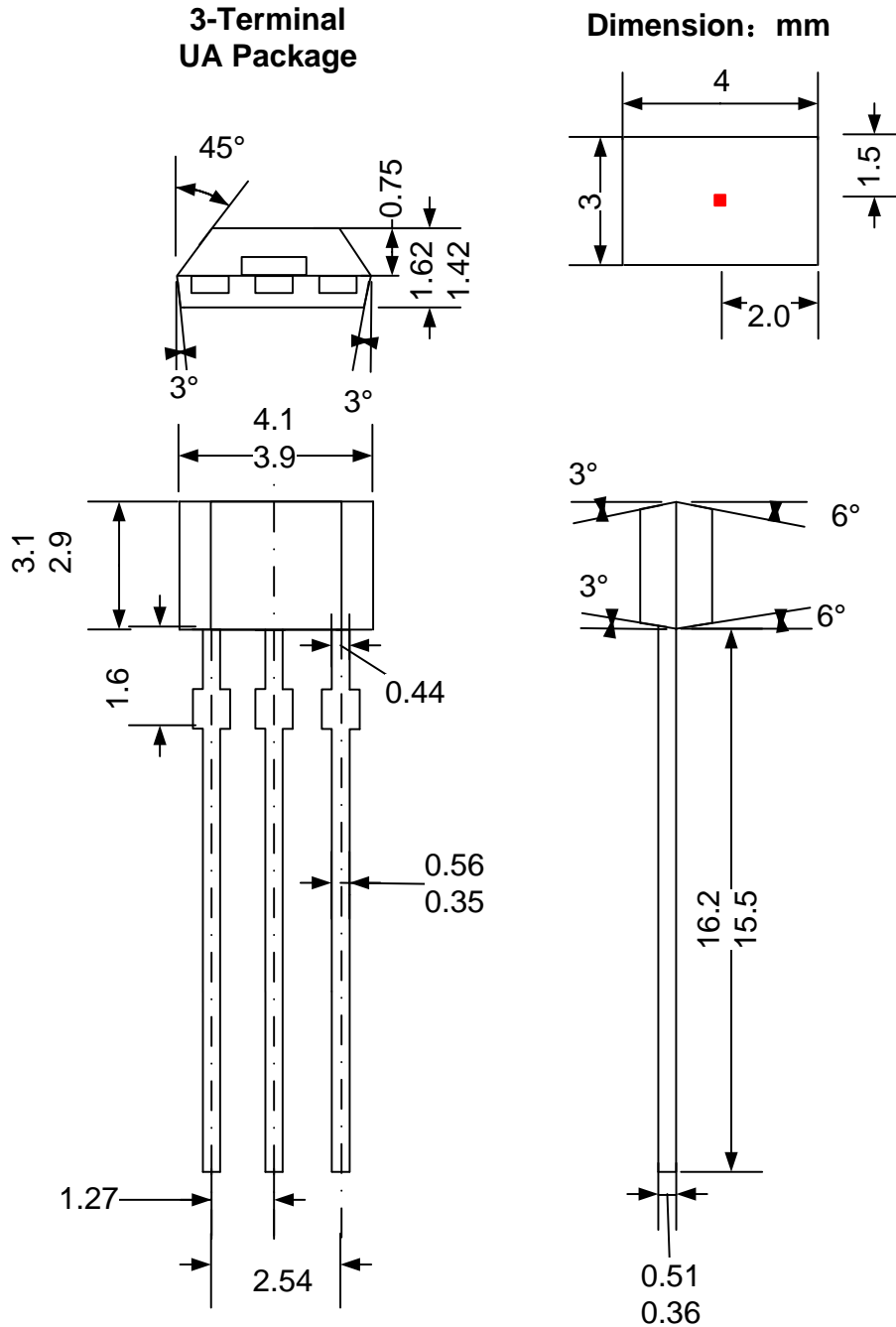

Notes:

1. Exact body and lead configuration at vendor's option within limits shown.
2. Height does not include mold gate flash.

Where no tolerance is specified, dimension is nominal.

REVISION HISTORY

Revision	Date	Description
Rev0.1	2016-05-07	Preliminary datasheet
Rev2.3	2019-12-18	The final revision of old datasheet
RevA/1.0	2020-11-19	Unified datasheet format

单击下面可查看定价，库存，交付和生命周期等信息

[>>Semiment \(赛卓电子\)](#)