High Performance Digital-Bipolar Hall Effect Sensor

FEATURES

- High chopping frequency
- Supports a wide voltage range
 - 2.8V to 40V
 - Operation from unregulated supply
- Wide operating temperature range
 - -40°C to 160°C
- Enable 40V load dump compliance
- Reverse-battery protection
- Output short-circuit protection
- High EMC immunity,
- Small package
 - 3-pin SIP -(UA)
 - 3-pin SOT23 -(SO)

APPLICATIONS

- Automotive
- Flow meters
- Valve and solenoid status
- BLDC motors with sensors
- Proximity sensing
- Tachometers

DESCRIPTION

The SC2498 is a Hall-effect latch designed in BCD process technology. The device integrates a voltage regulator, Hall sensor with dynamic offset cancellation system, Schmitt trigger and an open-drain output driver, all in a single package.

The wide operating voltage range and extended choice of temperature range make it suitable for use in automotive, industrial and consumer applications.

The device is available in a 3-pin SIP package (UA) and a 3-pin SOT-23 package (SO). Both are lead (Pb) free, with 100% matte tin lead-frame plating.



CONTENTS

FEATURES	- 1 -	TYPICAL CHARACTERISTIC	- 8 -
APPLICATIONS	- 1 -	TYPICAL CHARACTERISTIC (Continued)	- 9 -
DESCRIPTION	- 1 -	FUNCTION DESCRIPTION	- 9 -
BLOCK DIAGRAM	- 3 -	<i>Field Direction Definition</i>	- 10 -
ORDERING INFORMATION	- 3 -	<i>Transfer Function</i>	- 10 -
TERMINAL CONFIGURATION	- 4 -	RECOMMEND APPLICATION	- 11 -
ABSOLUTE MAXIMUM RATINGS	- 5 -	PACKAGE INFORMATION “UA”	- 12 -
ESD PROTECTION	- 5 -	PACKAGE INFORMATION “SO”	- 14 -
EMC	- 5 -	REVISION HISTORY	- 15 -
THERMAL CHARACTERISTICS	- 5 -		
OPERATING CHARACTERISTICS	- 6 -		
<i>Electrical Characteristics</i>	- 6 -		
<i>Magnetic Characteristics</i>	- 7 -		

BLOCK DIAGRAM.

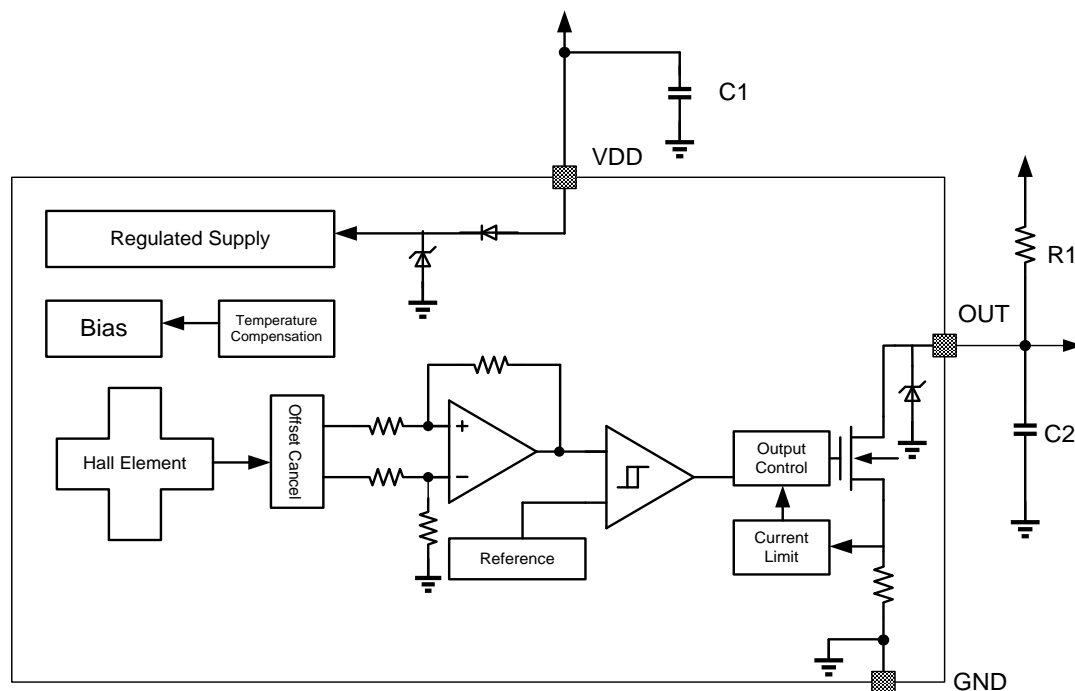

C2 is included in package of SC2498CUA-N.

ORDERING INFORMATION

Part Number	Packing	Mounting	Marking	Ambient, T_A	$B_{OP}(Typ.)$	$B_{RP}(Typ.)$
SC2498UA-N	1000 pieces/bag	3-pin SIP	2498 D/C	-40°C to 160°C	-8.0mT	+8.0mT
SC2498CUA-N	1000 pieces/bag	3-pin SIP	2498C D/C		-8.0mT	+8.0mT
SC2498SO	3000 pieces/reel	3-pin SOT-23	2498X (X is D/C)		+8.0mT	-8.0mT

TERMINAL CONFIGURATION

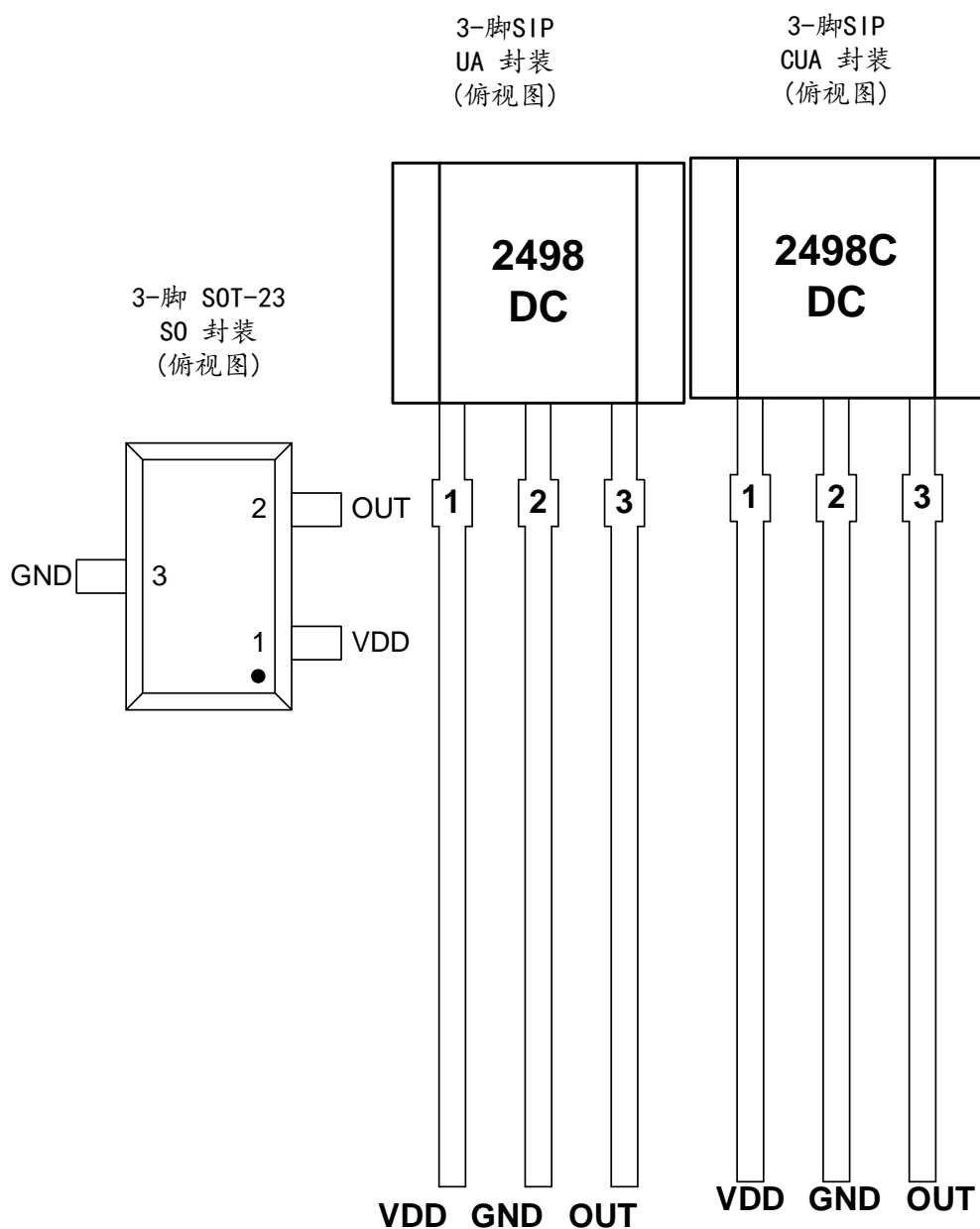

Name	Terminal Number		Type	Description
	UA	SO		
VDD	1	1	PWR	2.8 to 40V power supply
GND	2	3	Ground	Ground terminal
OUT	3	2	Output	Open-drain output. The open drain requires a pull-up resistor.

ABSOLUTE MAXIMUM RATINGS

over operating free-air temperature range (unless otherwise noted) ⁽¹⁾

Parameter	Symbol	Min.	Max.	Units
Power supply voltage	V _{DD}	-43	43	V
Output terminal voltage	V _{OUT}	-0.5	43	V
Output terminal current sink	I _{SINK}	0	35	mA
Operating ambient temperature	T _A	-40	160	°C
Maximum junction temperature	T _J	-55	165	°C
Storage temperature	T _{STG}	-65	175	°C

⁽¹⁾ Stresses above those listed here may cause permanent damage to the device. Exposure to absolute maximum rating conditions for extended periods may affect device reliability.

ESD PROTECTION

Human Body Model (HBM) tests according to: standard AEC-Q100-002

Parameter	Symbol	Part number	Min.	Max.	Units
ESD-Protection	V _{ESD}	SC2498UA-N SC2498SO	-8	+8	KV
		SC2498CUA-N	-12	+12	KV

EMC

Ref: ISO 7637-2; 2nd edition 06/2004; conducted on supply line; V_S = 13.5 V, T = 25°C

Parameter	Symbol	Part number	Level	Status
Test pulse 3b	V _{EMC}	SC2498UA-N SC2498SO	150V	A
		SC2498CUA-N	800V	A

THERMAL CHARACTERISTICS

Symbol	Parameter	Test Conditions	Rating	Units
R _{θJA}	UA Package thermal resistance	Single-layer PCB, with copper limited to solder pads	166	°C/W
R _{θJA}	SO Package thermal resistance	Single-layer PCB, with copper limited to solder pads	228	°C/W

OPERATING CHARACTERISTICS

Electrical Characteristics

over operating free-air temperature range ($V_{DD} = 5.0V$, unless otherwise noted)

Symbol	Parameter	Test Conditions	Min.	Typ.	Max.	Units
SUPPLY CHARACTERISTICS						
V_{DD}	Operating voltage (1)	$T_J < T_J(\text{Max.})$	2.8	--	40	V
I_{DD}	Operating supply current	$V_{DD}=2.8$ to 40 V	3.5	4.1	7	mA
t_{on}	Power-on time		--	6	10	μS
OUTPUT CHARACTERISTICS						
I_{QL}	Off-state leakage current	Output Hi-Z	--	--	3	μA
V_{SAT}	Output saturation voltage	$V_{DD}=5V$, $I_O=20\text{mA}$	--	200	500	mV
t_d	Output delay time	B=BRP to BOP	--	15	25	μS
t_r	Output rise time (10% to 90%)	$R_1=1\text{Kohm}$ $C_o=50\text{pF}$	--	--	0.5	μS
t_f	Output fall time (90% to 10%)	$R_1=1\text{Kohm}$ $C_o=50\text{pF}$	--	--	0.2	μS
ON-BOARD PROTETION						
OCP	Over current protection	Output on VPULL-UP<30V	45	65	80	mA
$V_{Z(SLY)}$	Supply Zener Clamp Voltage	$I_{DD}=I_{DD}(\text{max})+3\text{mA}$	40	--	--	V
$V_{Z(OUT)}$	Output Zener Clamp Voltage	Output Hi-Z, $I_{OOUT}=1.5\text{mA}$	40	--	--	V
V_{RZ}	Reverse Battery Zener Clamp Voltage	$I_{DD}=-5\text{mA}$	40	--	--	V

(1) Maximum voltage must be adjusted for power dissipation and junction temperature, see Thermal Characteristics

Magnetic Characteristics

over operating free-air temperature range (unless otherwise noted)

Symbol	Parameter	Test Conditions	Min.	Typ.	Max.	Units
f _{BW}	Bandwidth		20	--	--	kHz
SC2498SO						
B _{OP}	Operated point	TA=-40°C to 160°C	6.5	8.0	12	mT
B _{RP}	Release point		-12	-8.0	-6.5	mT
B _{HYS}	Hysteresis		13	16	24	mT
SC2498UA-N						
B _{OP}	Operated point	TA=-40°C to 160°C	-12	-8.0	-6.5	mT
B _{RP}	Release point		6.5	8.0	12	mT
B _{HYS}	Hysteresis		13	16	24	mT
SC2498CUA-N						
B _{OP}	Operated point	TA=-40°C to 160°C	-12	-8.0	-6.5	mT
B _{RP}	Release point		6.5	8.0	12	mT
B _{HYS}	Hysteresis		13	16	24	mT

1mT=10GS

Magnetic flux density, *B*, is indicated as a negative value for North-polarity magnetic fields, and as a positive value for South-polarity magnetic fields.

TYPICAL CHARACTERISTIC

I_{DD} VS V_{DD}

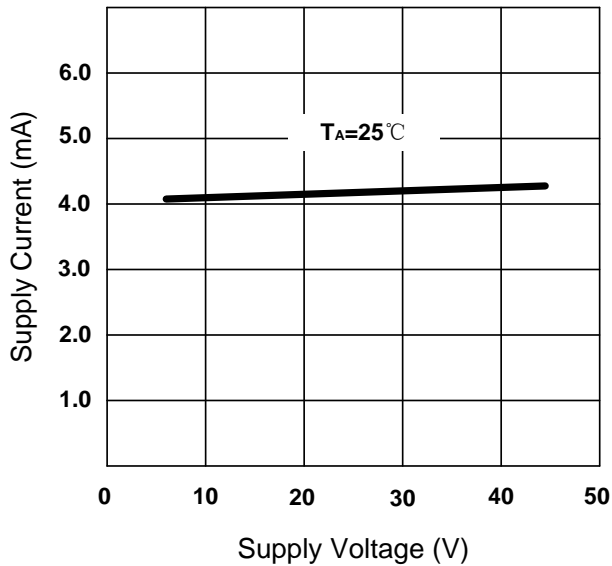

I_{DD} VS T_A

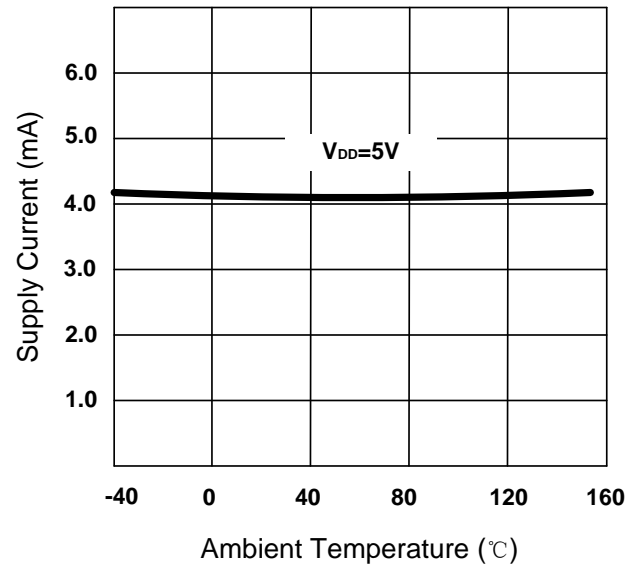

V_{Q(sat)} VS V_{DD}

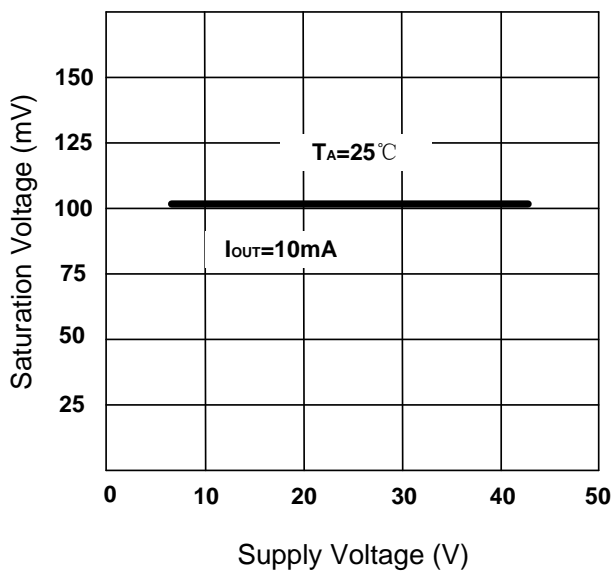

V_{Q(sat)} VS T_A

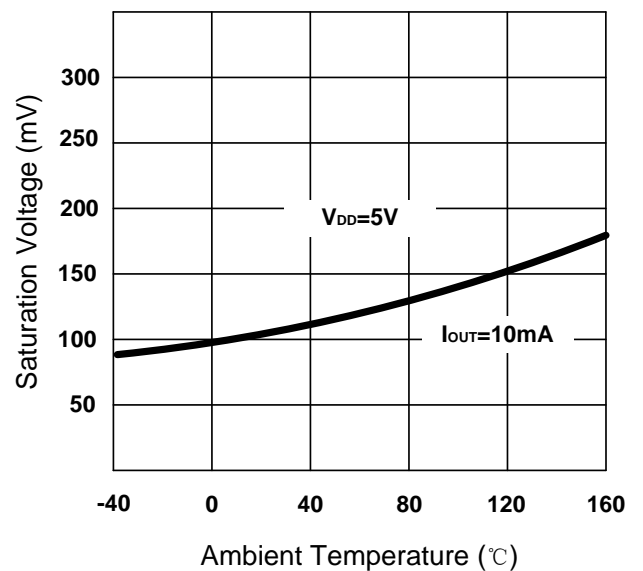

TYPICAL CHARACTERISTIC (Continued)

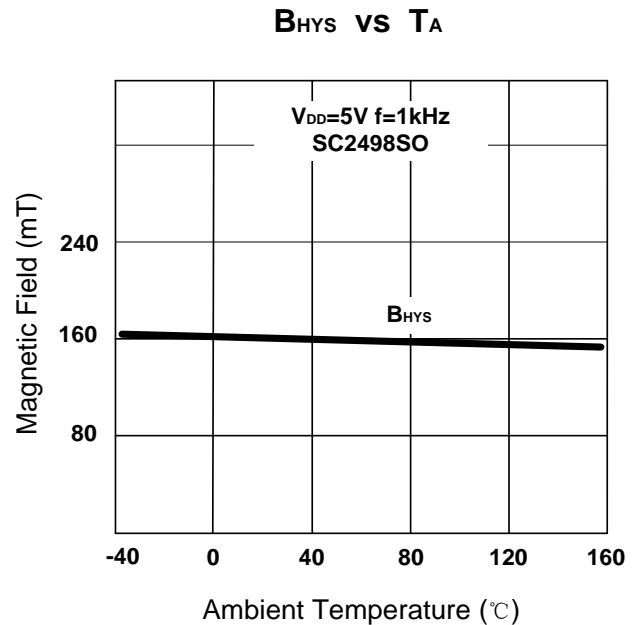
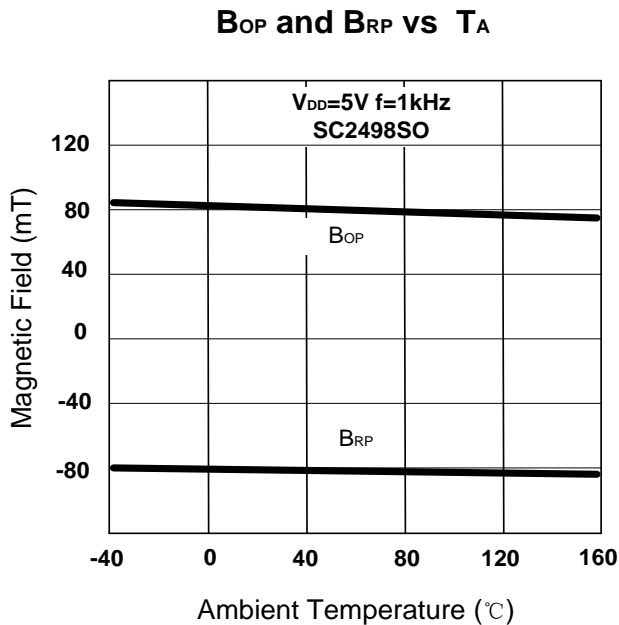

FUNCTION DESCRIPTION

The SC2498 device is a chopper-stabilized Hall sensor with a digital latched output for magnetic sensing applications. The device can be powered with a supply voltage between 2.8V and 40V. The device does not operate when -0.5 to 2.5V is applied to the VDD terminal (with respect to the GND terminal). In addition, the device can withstand voltages up to 45V for transient durations.

The output of SC2498 switches low (turns on) when a magnetic field (South polarity) perpendicular to the Hall element exceeds the operate point threshold, B_{OP}. After turn-on, the output is capable of sinking 30mA and the output voltage is V_{Q(sat)}. When the magnetic field is reduced below the release point, B_{RP}, the device output goes high (turns off). The difference in the magnetic operate and release points is the hysteresis, B_{HYS}, of the device. This built-in hysteresis allows clean switching of the output even in the presence of external mechanical vibration and electrical noise.

An external output pull-up resistor is required on the OUT terminal. The OUT terminal can be pulled up to V_{DD} or to a different voltage supply. This allows for easier interfacing with controller circuits.

Field Direction Definition

A positive magnetic field is defined as a South pole near the marked side of the package.

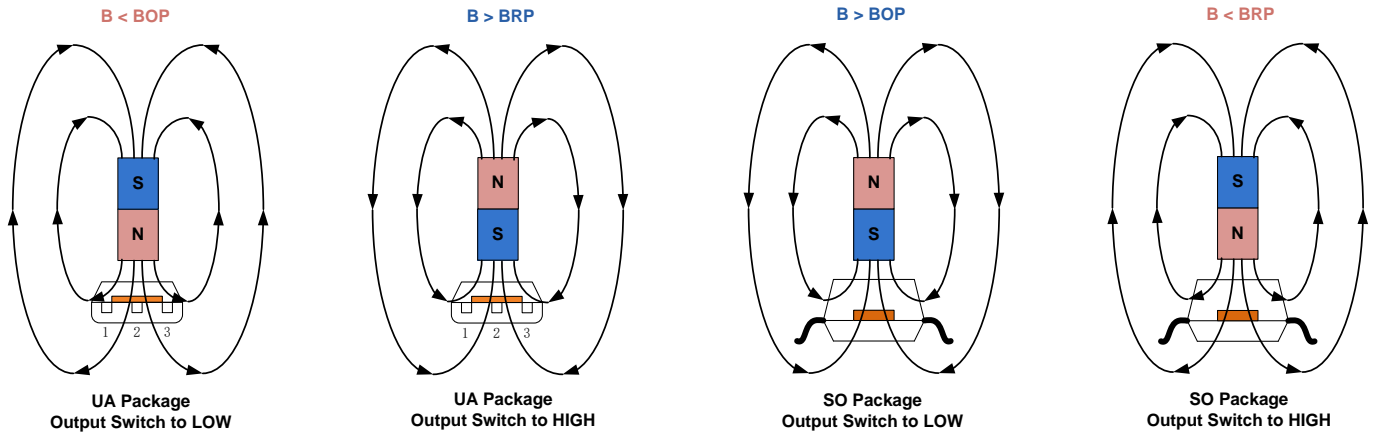

Transfer Function

Powering-on the device in the hysteresis region, less than B_{OP} and higher than B_{RP} , allows an indeterminate output state. The correct state is attained after the first excursion beyond B_{OP} or B_{RP} . If the field strength is greater than B_{OP} , then the output is pulled low. If the field strength is less than B_{RP} , the output is released.

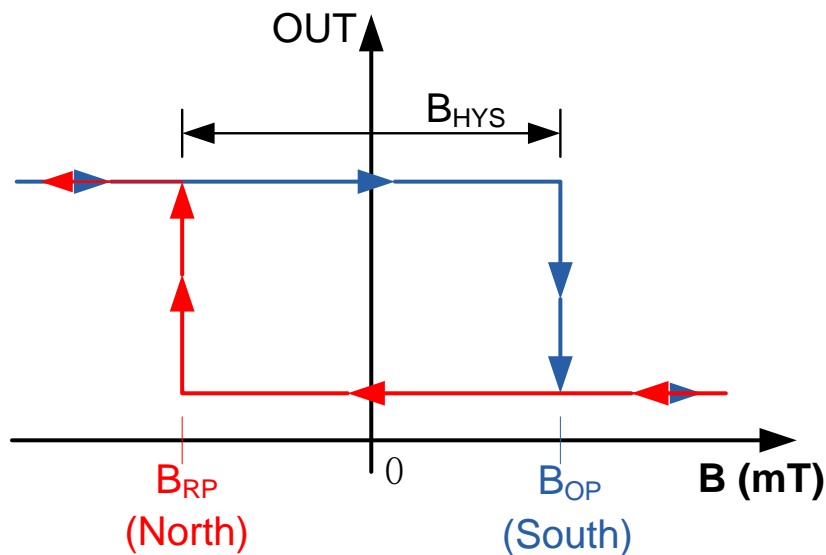

RECOMMAND APPLICATION

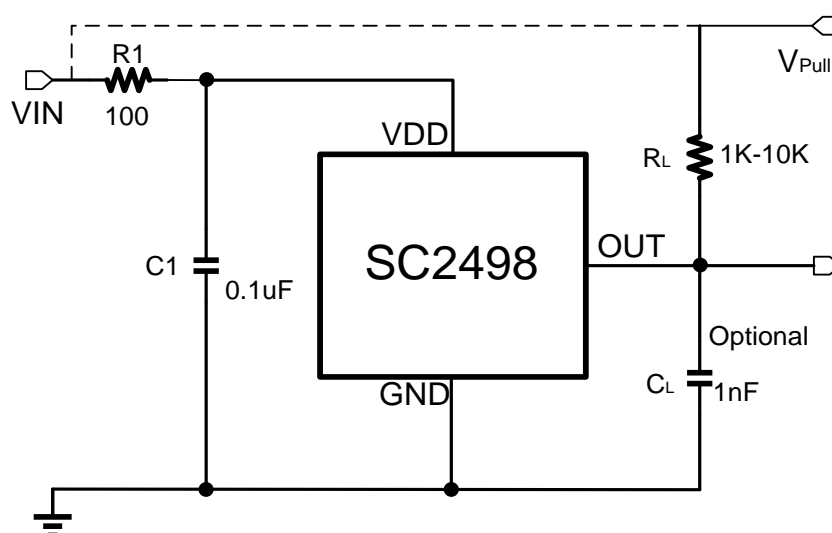

The SC2498 contains an on-chip voltage regulator and can operate over a wide supply voltage range. In applications that operate the device from an unregulated power supply, transient protection must be added externally. For applications using a regulated line, EMI/RFI protection may still be required. It is recommended that C1 capacitor be connected to the ground in parallel near the VDD power end of the chip, with a typical value of 0.1 μ F. At the same time in the external optional series resistor R1 and output capacitance C_L used for enhanced protection circuit, its typical values for 100 Ω and 1nF.

The SC2498 device output stage uses an open-drain NMOS, and it is rated to sink up to 30mA of current. For proper operation, calculate the value of the pull-up resistor R_L is required. The size of R_L is a tradeoff between OUT rise time and the load capacity when OUT is pulled low. A lower current is generally better, however faster transitions and bandwidth require a smaller resistor for faster switching.

Select a value for C_L based on the system bandwidth specifications as:

$$C_L = \frac{1}{2\pi \times R \times f \text{ (Hz)}}$$

V_{PULL} is not restricted to VDD, and could be connected to other voltage reference. The allowable voltage range of this terminal is specified in the Absolute Maximum Ratings.

PACKAGE INFORMATION “CUA”

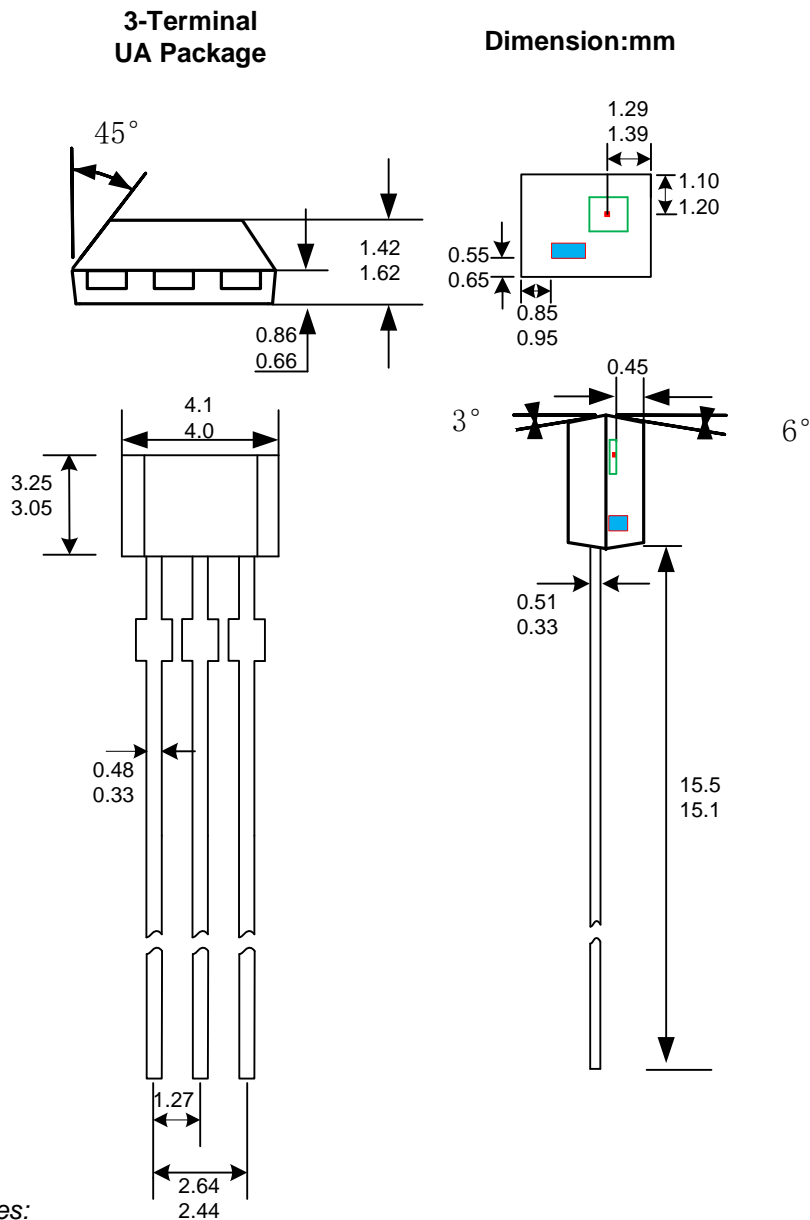

Notes:

1. Exact body and lead configuration at vendor 's option within limits shown.
2. Height does not include mold gate flash.
3. Green is Die; Red is Hall plate; Blue is Cap
4. Die Size: 1.14mm*1.02mm*0.3mm; Cap Size: 1.0mm*0.5mm*0.5mm

Where no tolerance is specified, dimension is nominal.

PACKAGE INFORMATION “UA”

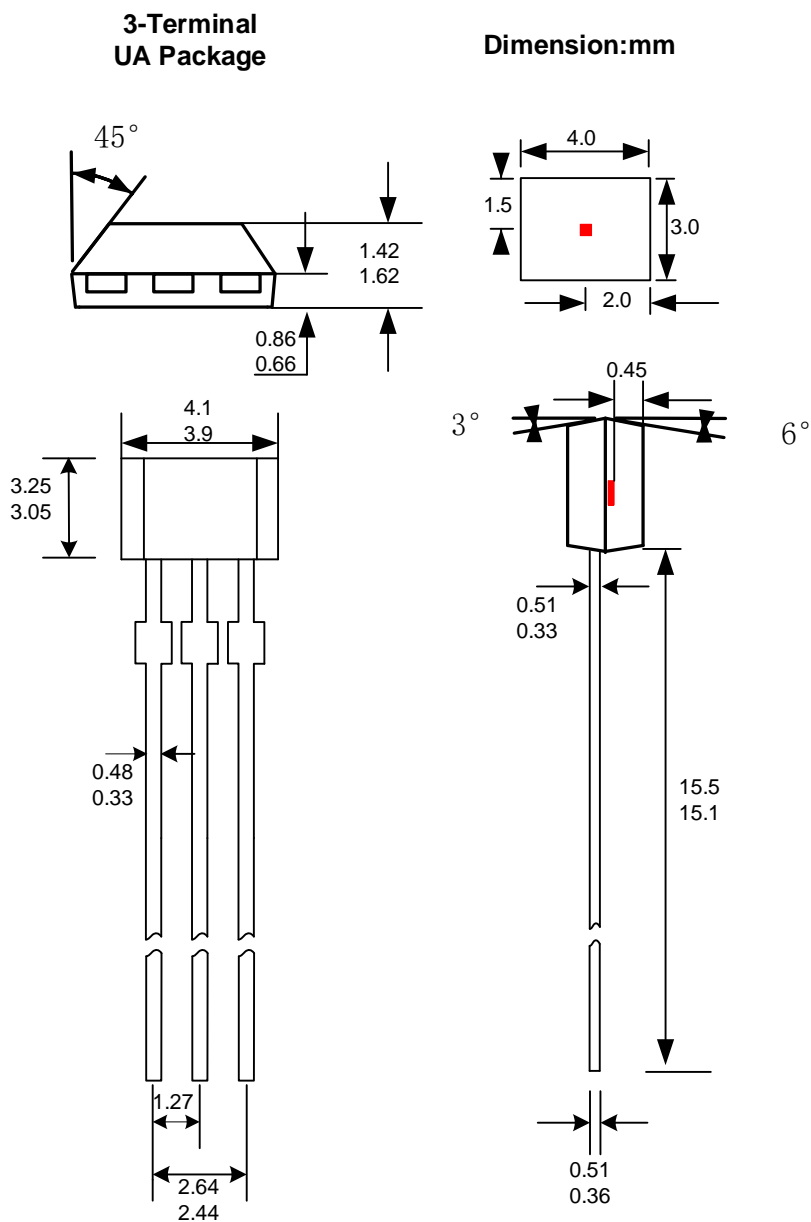

Notes:

1. Exact body and lead configuration at vendor's option within limits shown.
2. Height does not include mold gate flash.

Where no tolerance is specified, dimension is nominal.

PACKAGE INFORMATION “SO”

3-Terminal
SO Package

Dimension:mm

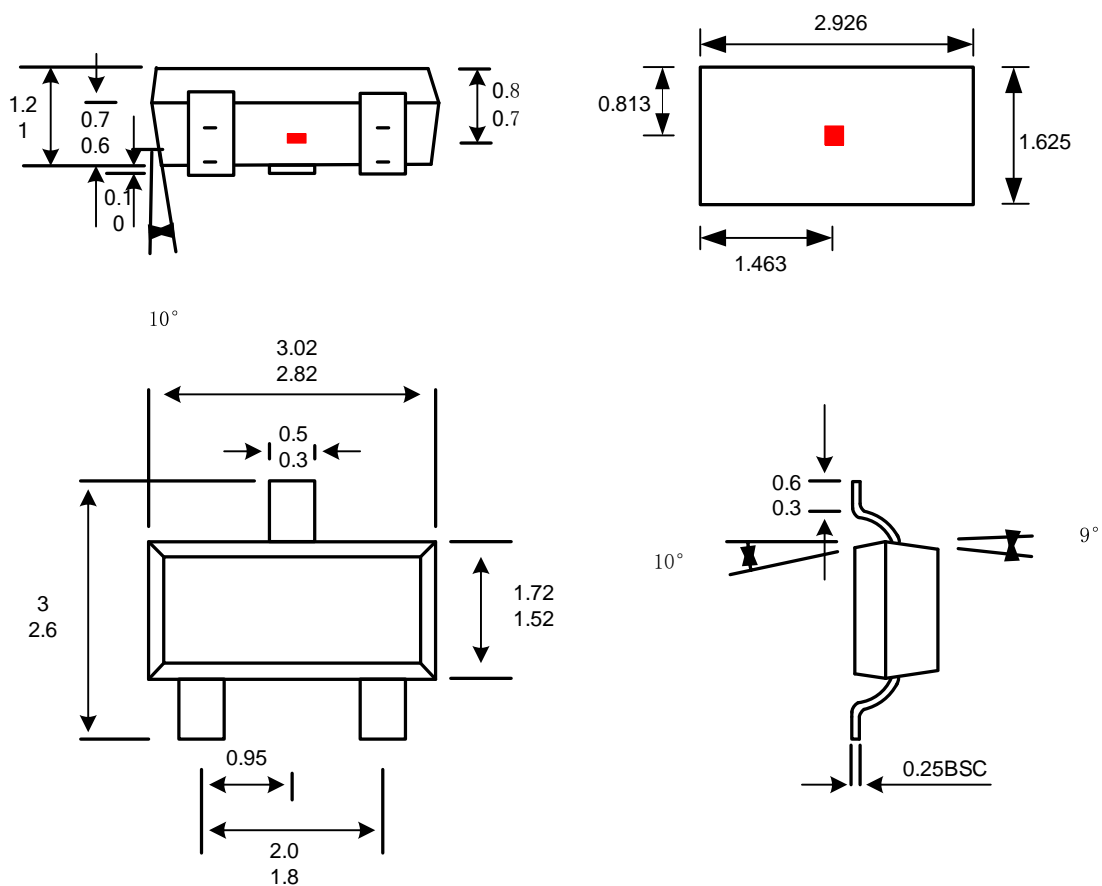

Notes:

1. Exact body and lead configuration at vendor's option within limits shown.
2. Height does not include mold gate flash.

Where no tolerance is specified, dimension is nominal.

REVISION HISTORY

Revision	Date	Description
Rev0.1	2022-1-08	Preliminary datasheet
Rev0.2	2022-04-27	1.Output terminal current sink from 40mA to 35mA 2.Power-on time max from 20us to 10us 3.UA package
RevA1.0	2023-08-10	Uniform format and update hall plate position
RevA1.1	2024-05-12	Update EC table
RevA1.2	2024-06-27	1.Add SC2498CUA-N part 2.Add ordering, ESD, EMC table

单击下面可查看定价，库存，交付和生命周期等信息

[>>Semiment \(赛卓电子\)](#)