

FEATURES

- Two-wire current interface
- High sensitivity
- Dynamic self-calibration principle
- South and North pole pre-induction possible
- Large air gap
- Single chip solution
- -40°C to 150°C operating temperature range
- Output protection against electrical disturbances

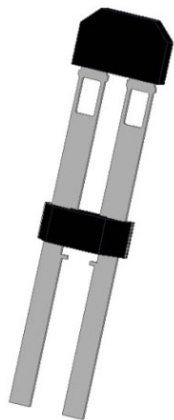

DESCRIPTION

The differential Hall Effect sensor SC9641TS-P detects the motion of ferromagnetic and permanent magnet structures by measuring the differential flux density of the magnetic field. To detect the motion of ferromagnetic objects the magnetic field must be provided by a back biasing permanent magnet. Either south or north pole of the magnet can be attached to the back side of the IC package.

Magnetic offsets of up to $\pm 20\text{mT}$ and device offsets are cancelled by a self-calibration algorithm. Only a few magnetic edges are necessary for self-calibration. After the offset calibration sequence, switching occurs when the input signal crosses the arithmetic mean of its max. and min. value (e.g. zero-crossing for sinusoidal signals).

The ON and OFF state of the IC are indicated by High and Low current consumption. Excellent accuracy and sensitivity are specified for harsh automotive requirements with a wide temperature range, high ESD and EMC robustness.

CONTENTS

FEATURES	- 1 -	OPERATING CHARACTERISTICS	- 7 -
DESCRIPTION	- 1 -	TYPICAL APPLICATION	- 8 -
BLOCK DIAGRAM	- 3 -	FUNCTIONAL DESCRIPTION	- 9 -
ORDERING INFORMATION	- 3 -	GEAR TOOTH SENSING	- 10 -
TERMINAL CONFIGURATION	- 4 -	PACKAGE INFORMATION	- 11 -
Absolute Maximum Ratings	- 5 -	REVISION HISTORY	- 12 -
ESD PROTECTION	- 5 -		
ELECTRO MAGNETIC COMPATIBILITY – (values depend on R_M!)	- 6 -		

BLOCK DIAGRAM

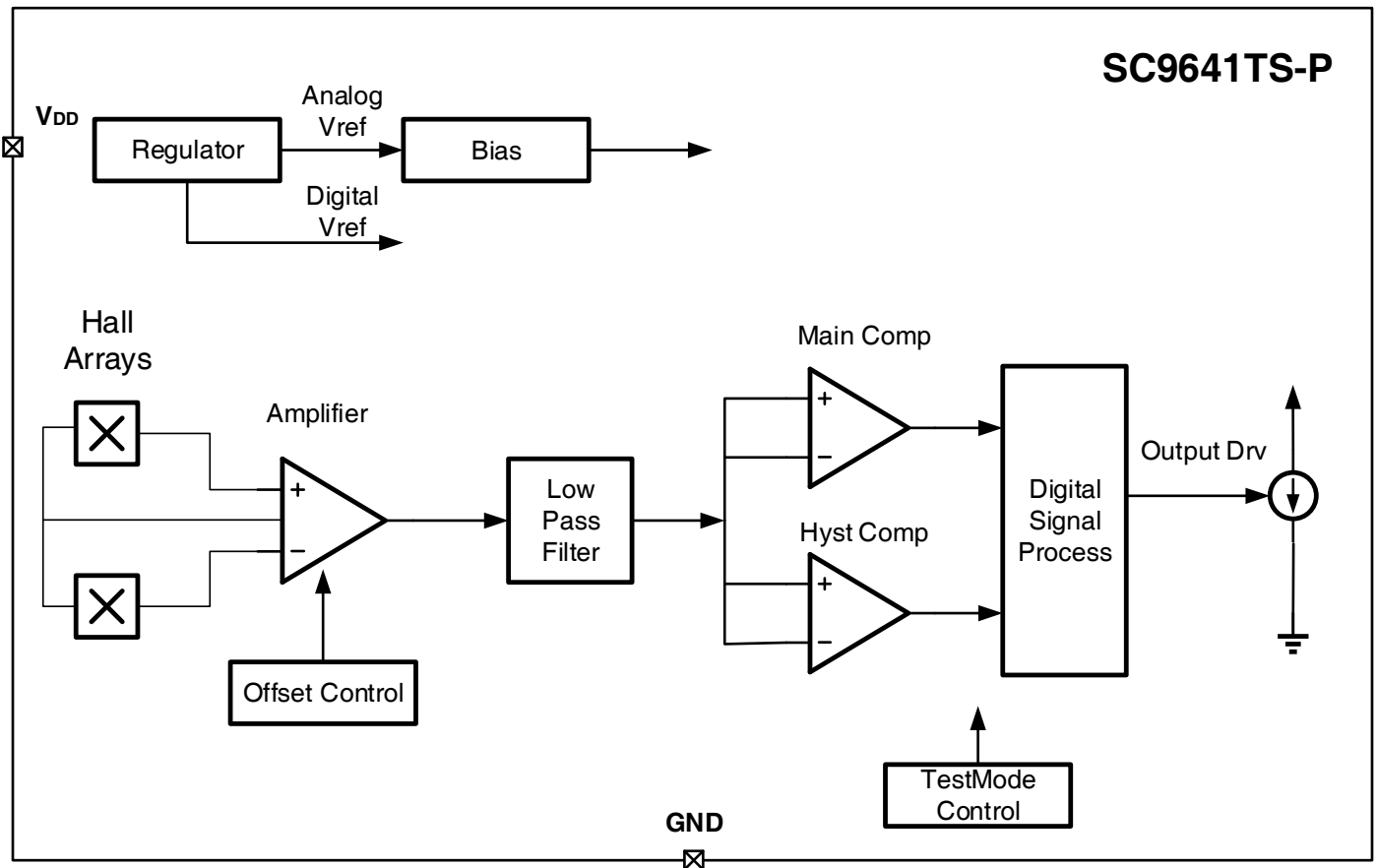

ORDERING INFORMATION

Part Number	Packing	Mounting	Ambient, T _A
SC9641TS-P	1500 pieces/bag	2-pin SIP	-40°C to 150°C

TERMINAL CONFIGURATION

2 Terminal SIP
Ts package
(TOP View)

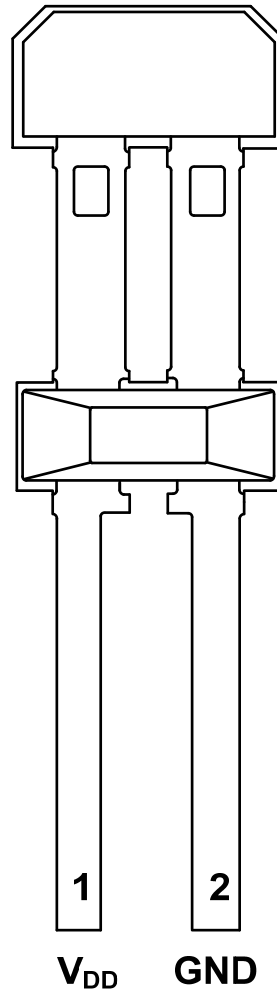

Terminal		Type	Description
Name	Number		
V _{DD}	1	PWR	4.5V ~ 24 V power supply
GND	2	Ground	Ground

Absolute Maximum Ratings

over operating free-air temperature range

Parameter	Symbol	Min.	Max.	Units
Power supply voltage	V_{DD}	-0.5	30	V
Output terminal voltage	V_{OUT}	-0.5	30	V
Output terminal current sink	I_{SINK}	0	20	mA
Operating ambient temperature	T_A	-40	150	°C
Maximum junction temperature	T_J	-55	165	°C
Storage Temperature	T_{STG}	-65	175	°C

Note: Stresses above those listed here may cause permanent damage to the device. Exposure to absolute maximum rating conditions for extended periods may affect device reliability.

ESD PROTECTION

Human Body Model (HBM) tests according to: standard AEC-Q100-002 HBM

Parameter	Symbol	Limit Values		Units
		Min.	Max.	
ESD-Protection	V_{ESD}	-5	5	kV

ELECTRO MAGNETIC COMPATIBILITY – (values depend on R_M !)

Ref. ISO 7637-1; see the test circuit for EMC tests;

$\Delta B_{PP} = 2\text{mT}$ (amplitude of sinus signal); $V_{DD} = 13.5\text{V}$, $f_B = 1\text{ kHz}$; $T_A = 25^\circ\text{C}$; $R_M \geq 75\ \Omega$;

Parameter	Symbol	Level / Typ.	Status
Test pulse 1	V_{EMC}	IV / -150V	C
Test pulse 2a		IV / 112V	C
Test pulse 3a		IV / -220V	A
Test pulse 3b		IV / 150V	A
Test pulse 5b		IV / 34V	C

1. Test criteria for status A: No missing pulse no additional pulse on the IC output signal plus duty cycle and jitter are in specification limits.
2. Test criteria for status B: No missing pulse no additional pulse on the IC output signal.
3. Test criteria for status C: One or more parameter can be out of specification during the exposure but returns automatically to normal operation after exposure is removed.

Test circuit for EMC tests

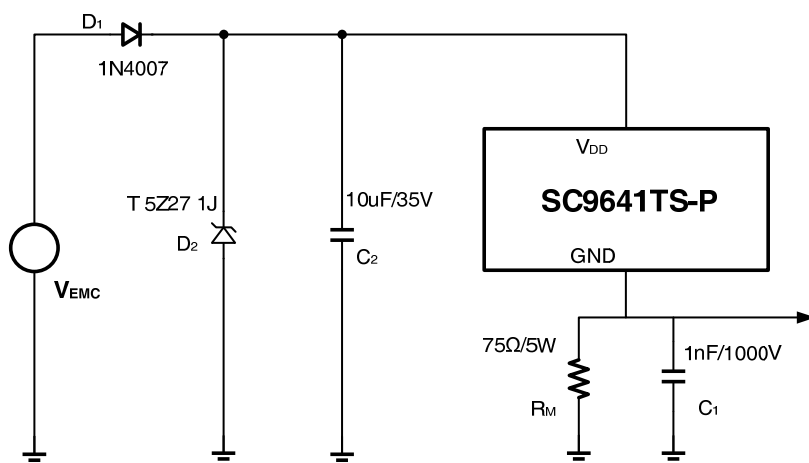

OPERATING CHARACTERISTICS

over operating free-air temperature range ($V_{DD}=12V$, unless otherwise noted)

Symbol	Parameter	Test Conditions	Min.	Typ.	Max.	Units
Electrical parameters						
V_{DD}	Operating voltage	$T_J < T_{J(max)}$	4.5	--	24	V
$I_{(Low)}$	Operating supply current	$V_{DD}=4.5V$ to 24 V	5.9	6.8	8.4	mA
$I_{(High)}$	Operating supply current	$V_{DD}=4.5V$ to 24 V	11.8	14.1	16.8	mA
I_{Ratio}	Supply current ratio	$I_{(High)} / I_{(Low)}$	1.9	2.1	2.3	--
t_{po}	Power-on time	$V_{DD} > 4.5V$	--	--	100	μs
DC	Duty Cycle	$V_{DD}=12V, \Delta B > 2mT$, Sine wave	40	50	60	%
S_{Jit_close}	Jitter, $T_J < 150^\circ C$, $1Hz < f_{mag} < 2500Hz$	$V_{DD}=12V, \Delta B > 2mT$, Sine wave	-2	--	+2	%
Magnetic Characteristics						
B_0	Pre-induction		-500	--	+500	mT
$\Delta B_{stat,l/r}$	Pre-induction offset between outer probes		-20	--	+20	mT
ΔB	Differential Induction	$f=1kHz, B_{diff}=5mT$	-120	--	+120	mT
B_{HYS}	Hysteresis		0.3	0.7	1.5	mT
f_{mag}	Magnetic signal frequency		1	--	10000	Hz

TYPICAL APPLICATION

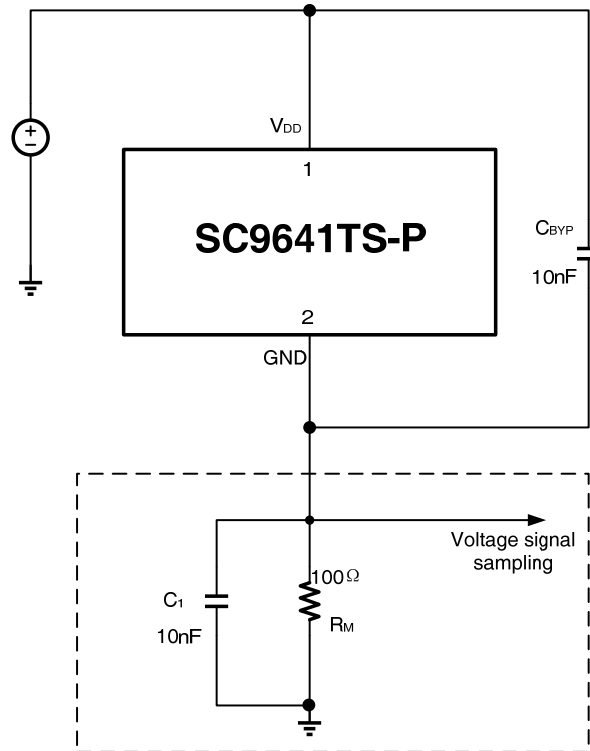

FUNCTIONAL DESCRIPTION

The SC9641TS-P is an optimized Hall Effect sensing integrated circuit that provides a user-friendly solution for ring-magnet sensing in two-wire applications. This small package can be easily assembled used in conjunction with a wide variety of target shapes and sizes.

The integrated circuit incorporates a dual-element Hall Effect sensor and signal processing that switches to differential magnetic signals created by ring magnet poles. The circuitry contains a sophisticated digital circuit to reduce system offsets and to calibrate the gain for air-gap-independent switch points.

The regulated current output is configured for two-wire applications and the sensor is ideally suited for obtaining speed and duty cycle information in ABS (antilock braking systems). The 2.0 mm spacing between the dual Hall elements is optimized for fine pitch ring-magnet-based configurations. The package is lead (Pb) free, with 100% matte tin lead frame plating

GEAR TOOTH SENSING

In the case of ferromagnetic toothed wheel application, the IC can be biased by the South or North pole of a permanent magnet which should cover both Hall probes

The maximum air gap depends on:

- the magnetic field strength (magnet used; pre-induction), and
- the toothed wheel that is used (dimensions, material, etc.)

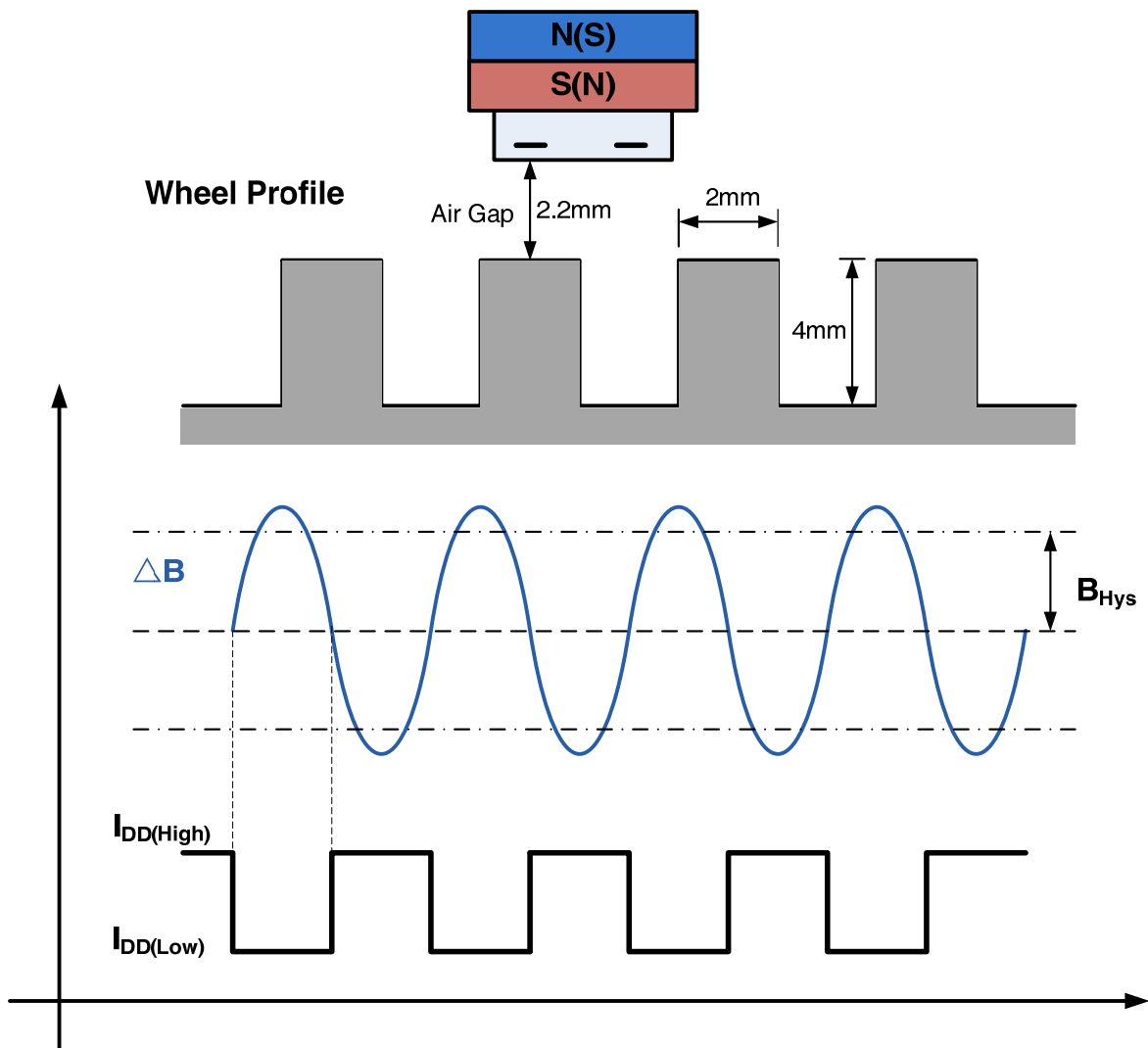

PACKAGE INFORMATION

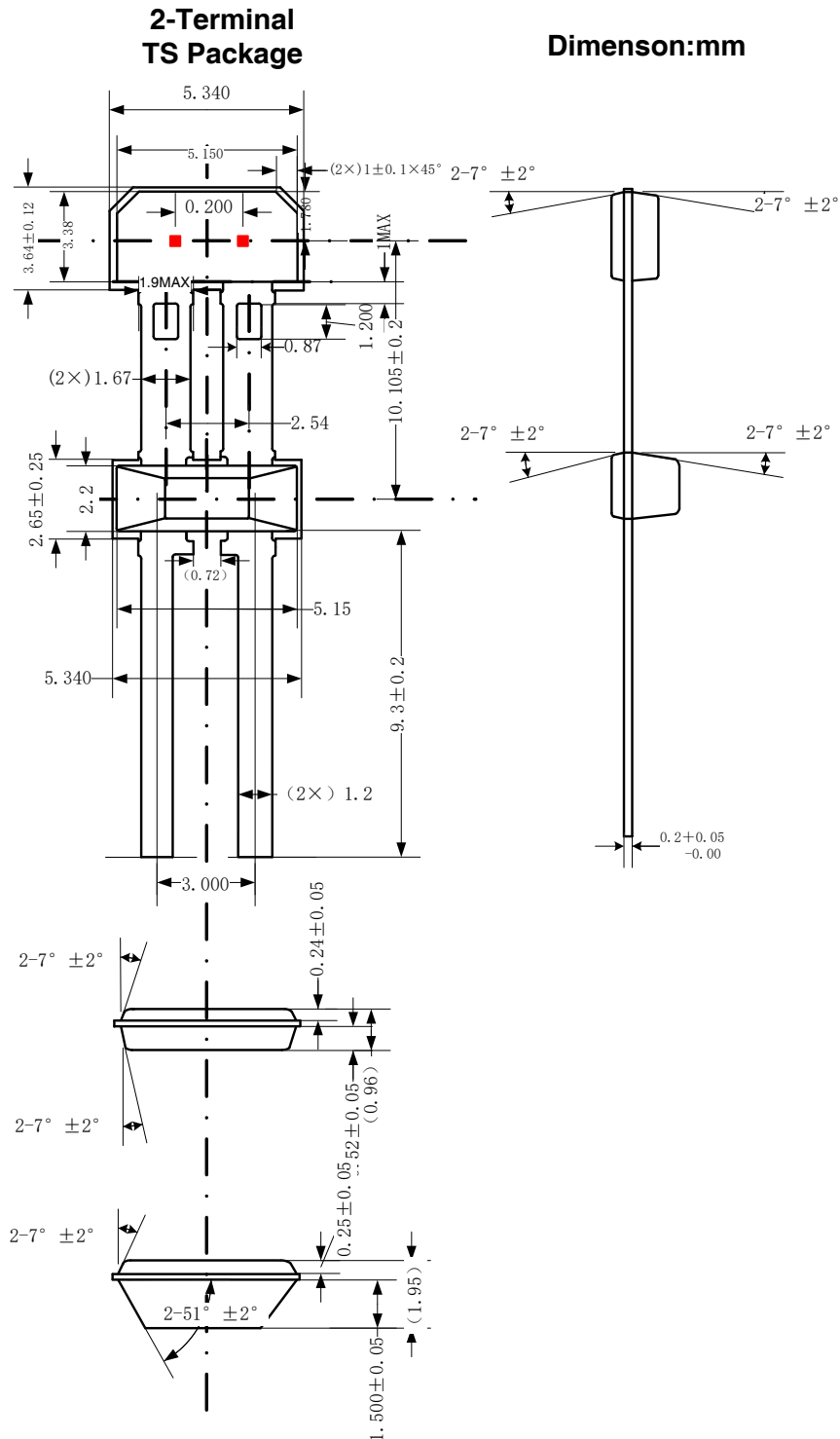

Notes:

1. Exact body and lead configuration at vendor option within limits shown.
2. Height does not include mold gate flash.

Where no tolerance is specified, dimension is nominal.

REVISION HISTORY

Revision	Date	Description
Rev0.1	2017-03-08	The Preliminary revision
Rev2.3	2018-09-17	The final revision of old datasheet
RevA/1.0	2020-11-19	Unified datasheet format

单击下面可查看定价，库存，交付和生命周期等信息

[>>Semiment \(赛卓电子\)](#)