

ZH6350B Three-Phase PN Half-Bridge Pre-Driver with Buck Regulator

Features:

- Up to 40V, Three-Phase PN Half-Bridge Drive
- Drive Capability: 100mA
- Integrated DCDC Buck Regulator
- Hot plug shoot-through protection
- Logic shoot-through protection
- Adaptive Dead Time
- Undervoltage Protection
- Available in SOP-16 and QFN-16 package

Product Applications:

- Fans
- Water Pumps
- Blowers
- Power Tools with Currents Below 20A
- Other Three-Phase Motor Drives

Pin Diagram and Pin Description:

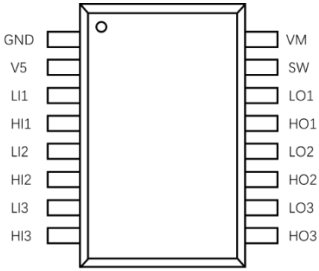
Pin Diagram	Number	Symbol	I/O	Function Description
 <p>SOP-16 (ZH6350BEC)</p>	1	GND	P	Ground
	2	V5	O	DCDC feedback and supply
	3	LI1	I	Channel 1 low-side input
	4	HI1	I	Channel 1 high-side input
	5	LI2	I	Channel 2 low-side input
	6	HI2	I	Channel 2 high-side input
	7	LI3	I	Channel 3 low-side input
	8	HI3	I	Channel 3 high-side input
	9	HO3	O	Channel 3 high-side output
	10	LO3	O	Channel 3 low-side output
	11	HO2	O	Channel 2 high-side output
	12	LO2	O	Channel 2 low-side output
	13	HO1	O	Channel 1 high-side output
	14	LO1	O	Channel 1 low-side output
	15	SW	O	DCDC oscillator terminal
	16	VM	P	Power supply

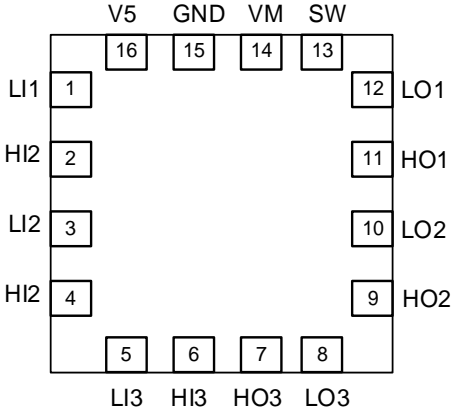
Pin Diagram	Number	Symbol	I/O	Function Description
 <p>QFN-16 (ZH6350BNC)</p>	1	LI1	I	Channel 1 low-side input
	2	HI1	I	Channel 1 high-side input
	3	LI2	I	Channel 2 low-side input
	4	HI2	I	Channel 2 high-side input
	5	LI3	I	Channel 3 low-side input
	6	HI3	I	Channel 3 high-side input
	7	HO3	I	Channel 3 high-side output
	8	LO3	I	Channel 3 low-side output
	9	HO2	O	Channel 2 high-side output
	10	LO2	O	Channel 2 low-side output
	11	HO1	O	Channel 1 high-side output
	12	LO1	O	Channel 1 low-side output
	13	SW	O	DCDC oscillator terminal
	14	VM	P	Power supply
	15	GND	P	Ground
	16	V5	O	DCDC feedback and supply

Absolute Maximum Ratings:

Parameter	Symbol	Value	Unit
Supply Voltage	VM	40	V
Operating Junction Temperature	T _J	-40~125	°C
High-Side Output Voltage	VO _{HI}	VM-6 ~ VM+1	V
Low-Side Output Voltage	VO _{LOW}	-1~6	V
Control Input Voltage	VI	-1~6	V
Peak Output Current	I _{SW_PEAK}	1	A
SW Output Voltage	SW	40	V
V5 Output Voltage	V5	6	V

Recommended Operating Conditions:

Parameter	Symbol	Rated Value	Unit
Supply Voltage	VM	5~40	V
Control Input Voltage	V _{INX}	0~5	V
DCDC Output Current	I _{DCDC}	50	mA
Ambient Temperature	T _A	-40~115	°C

Ordering Information:

Full Name	Package	Packaging	Quantity
ZH6350BNC	QFN-16	Reel	5000
ZH6350BEC	SOP-16	Reel	4000

Electrical Characteristics:

(T_A=25°C, VM=24V)

Parameter	Symbol	Test Conditions	Min	Typical	Max	Unit
Operating Current	ICC	H _{Ix} =0, L _{Ix} =0	-	80	-	uA
		H _{Ix} =0, L _{Ix} =1	-	80	-	uA
		H _{Ix} =1, L _{Ix} =0	-	80	-	uA
Input High Voltage	V _{INH}		-	1.85	-	V
Input Low Voltage	V _{INL}		-	0.85	-	V
Pull-down Resistor	R _{PD}		-	150k	-	Ω
Output Impedance	R _{OH}	H _{Ix} =0, H _{Ox} =VM-0.2V	-	5	-	Ω
		L _{Ix} =0, L _{Ox} =0.2V	-	5	-	Ω
Drive Current	I _{H_ON}	H _{Ix} =1, H _{Ox} =VM	-	100	-	mA
	I _{H_OFF}	H _{Ix} =0, H _{Ox} =VM-5	-	100	-	mA
	I _{L_ON}	L _{Ix} =1, L _{Ox} =0	-	25	-	mA
	I _{L_OFF}	L _{Ix} =0, L _{Ox} =5	-	50	-	mA
Undervoltage Threshold		Output off	-	2.8	-	V

Application Reference Circuit:

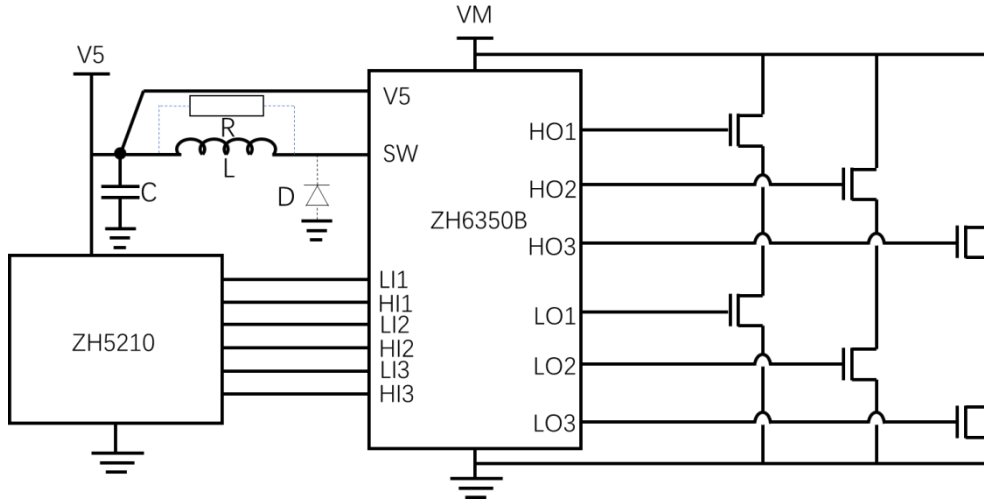

Pre-Driver Input/Output Waveforms:

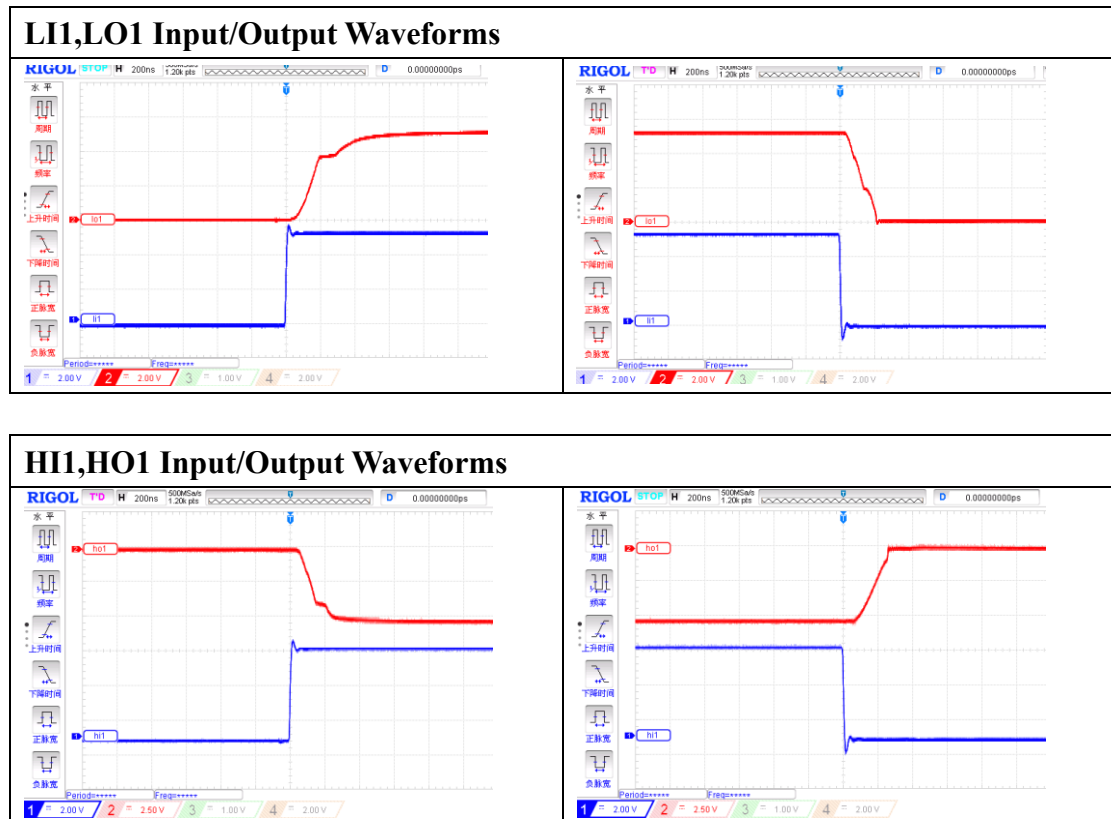

Note: HO1 experimental waveform acquisition uses an isolated probe, with one end connected to VM and the other end to HO.

DC/DC output waveform

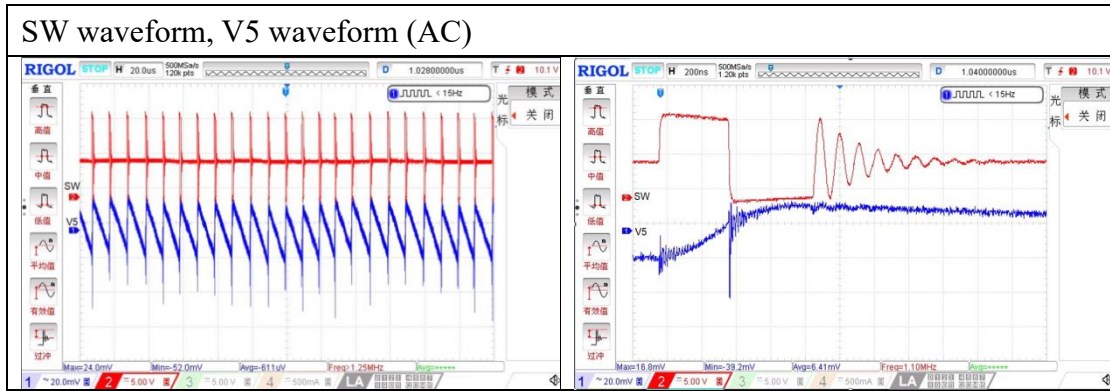

DC/DC parameter curve

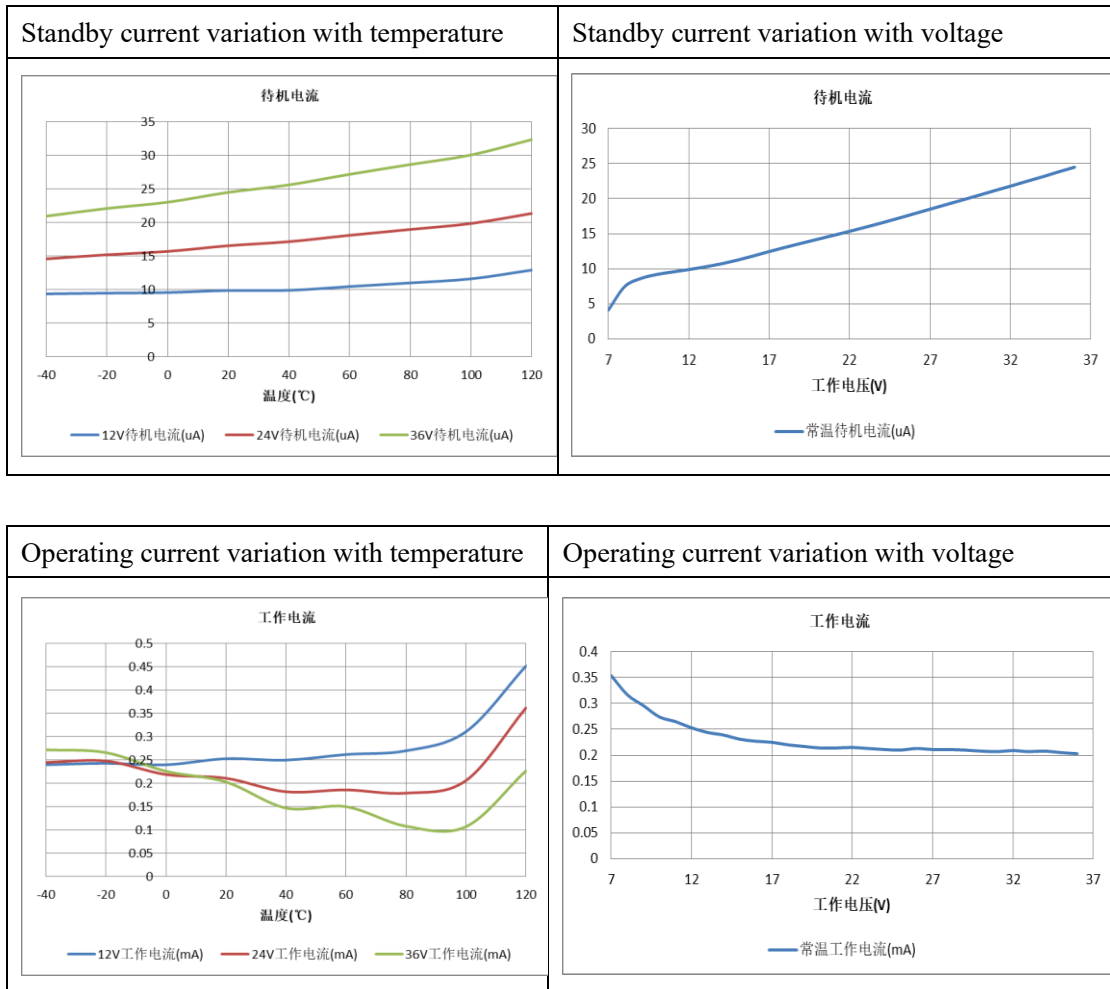

SW fixed on-time variation with VM

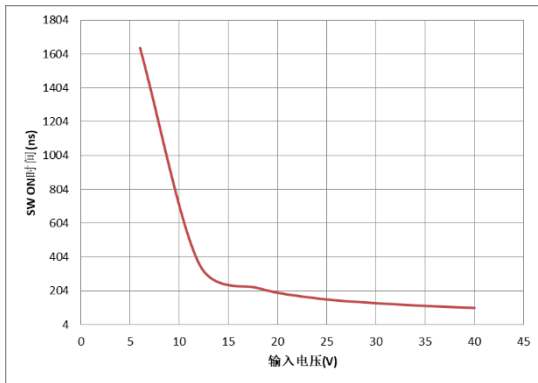

Circuit configuration: L=10uH, C=10uF

VM = 12V, V5 variation with load current under different temperature conditions

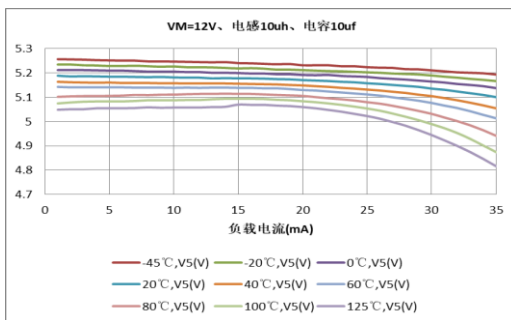

VM = 24V, V5 variation with load current under different temperature conditions

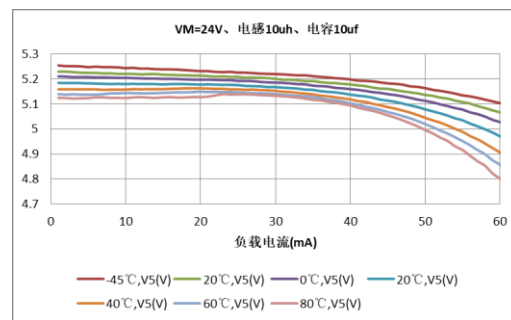

At room temperature, VM = 12V V5 variation with load current SW frequency variation with load current

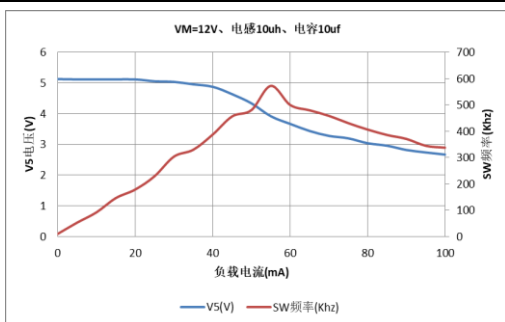

At room temperature, VM = 24V V5 variation with load current SW frequency variation with load current

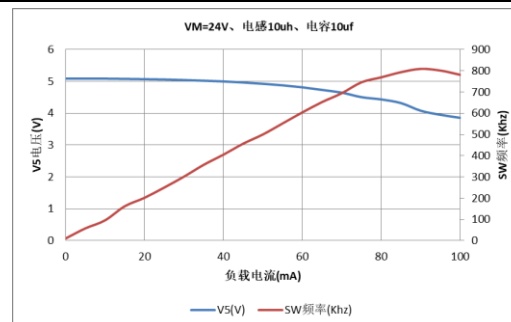

At room temperature, load current is 1mA V5 variation with input voltage SW frequency variation with input voltage

At room temperature, with a load current of 20mA V5 variation with input voltage SW frequency variation with input voltage

<p>负载电流1mA, 电感10uh, 电容10uf</p>	<p>负载电流20mA, 电感10uh, 电容10uf</p>
<p>At room temperature, VM = 12V, load current is 1mA V5 variation with temperature SW frequency variation with temperature</p>	<p>At room temperature, VM = 12V, load current is 20mA V5 variation with temperature SW frequency variation with temperature</p>
<p>VM=12V, 负载电流1mA, 电感10uh, 电容10uf</p>	<p>VM=12V, 负载电流20mA, 电感10uh, 电容10uf</p>
<p>At room temperature, VM = 24V, load current is 1mA V5 variation with temperature SW frequency variation with temperature</p>	<p>At room temperature, VM = 24V, load current is 20mA V5 variation with temperature SW frequency variation with temperature</p>
<p>VM=24V, 负载电流1mA, 电感10uh, 电容10uf</p>	<p>VM=24V, 负载电流20mA, 电感10uh, 电容10uf</p>

Circuit configuration: L=6.8uH, C=10uF, D=1N5819

VM = 12V, V5 variation with load current under different temperature conditions

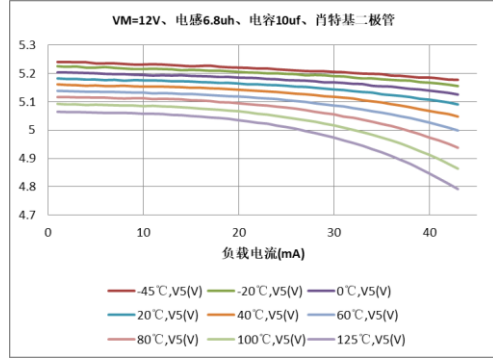

VM = 24V, V5 variation with load current under different temperature conditions

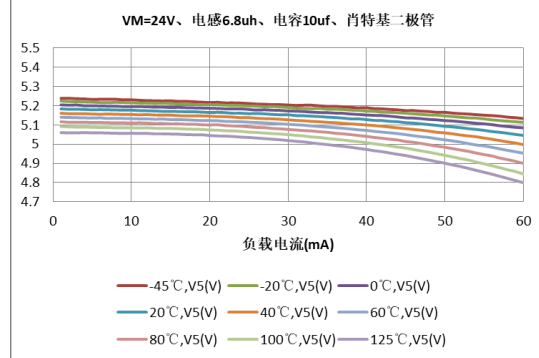

Circuit configuration: L=4.7uH, C=10uF, D=1N5819

VM = 12V, V5 variation with load current under different temperature conditions

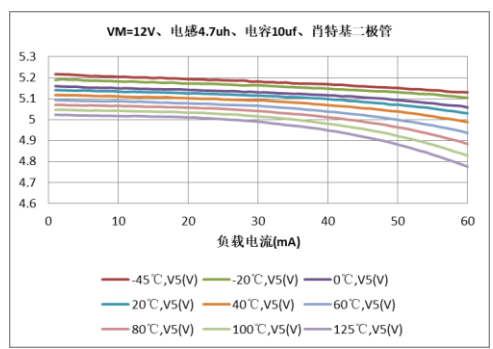

VM = 24V, V5 variation with load current under different temperature conditions

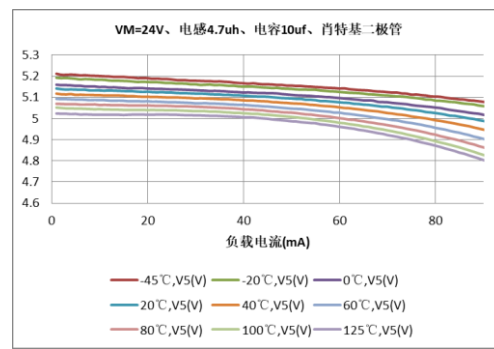

Circuit configuration: R=100Ω, C=10uF

VM = 12V, V5 variation with load current under different temperature conditions

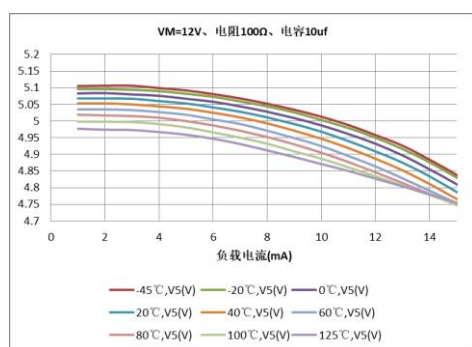

VM = 24V, V5 variation with load current under different temperature conditions

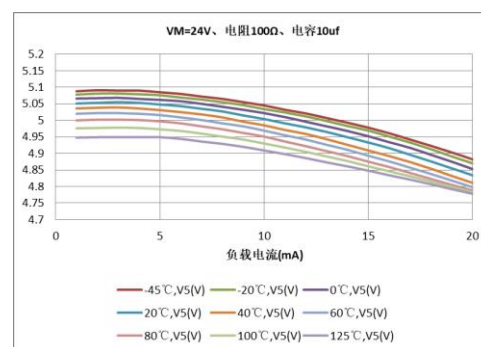

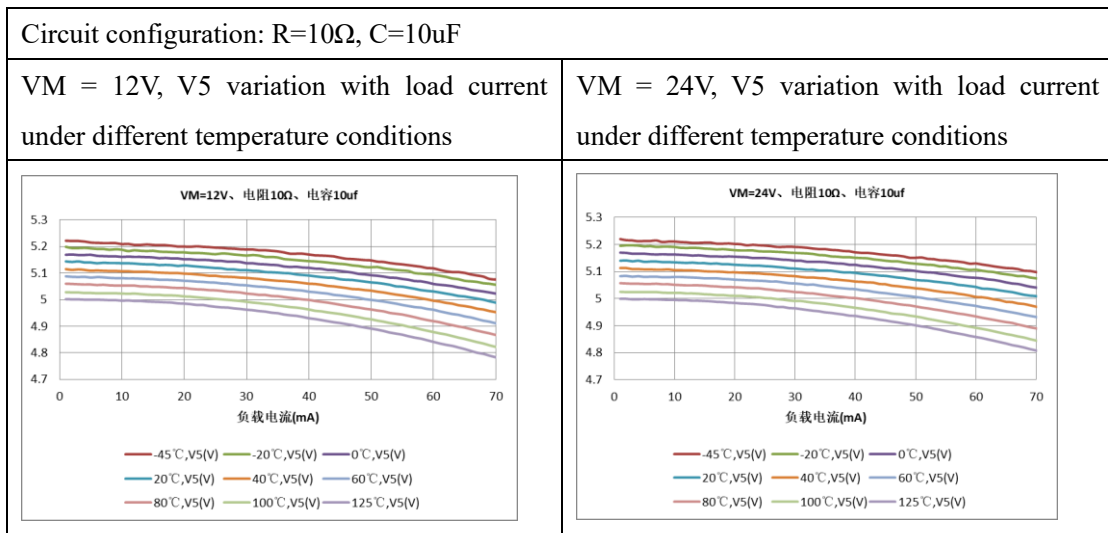
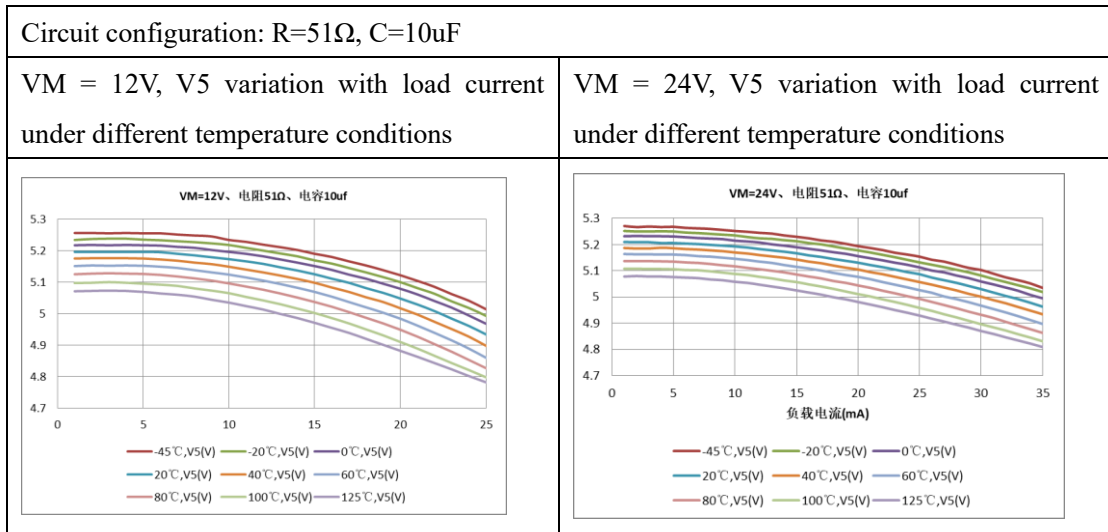

Detailed description:

The ZH6350B is a PN pre-driver chip suitable for 5V to 40V three-phase BLDC applications. The DC-DC module within is based on a Constant-On-Time (COT) Buck converter circuit. It integrates an upper bridge switch MOSFET and a lower bridge switch MOSFET for synchronous rectification. The on-time decreases as the input voltage increases, thereby maintaining a relatively stable peak current. With a minimum off-time, the ZH6350B operates only in Discontinuous Conduction Mode (DCM).

The DC-DC module requires no compensation capacitor or bootstrap capacitor, achieving the buck conversion function with the simplest external components. Inductors can be selected as a 10uH power inductor, or two 22uH, 0805 SMD inductors in series (totaling 44uH when connected in series). In low-power applications where extreme cost-effectiveness is desired, the inductor can be replaced with a resistor, with a recommended value of 100Ω, adjustable based on the required power. The power dissipation of the resistor is (VM-5V) multiplied by the output current, so please choose the resistor's power rating accordingly.

Inductor mode load level options:

Supply Voltage	Load Capability	Device Configuration
12V	5mA	L=Two 22uH inductors in series (0805 package) C=10uf
24V	5mA	L = Two 22uH inductors in series (0805 package) C = 10uF
12V	30mA	L=10uh(power inductor) C=10uf
24V	50mA	L=10uh(power inductor) C=10uf
12V	40mA	L=6.8uh(power inductor) C=10uf D=1N5819
24V	60mA	L=6.8uh(power inductor) C=10uf D=1N5819
12V	60mA	L=4.7uh(power inductor) C=10uf

		D=1N5819
24V	90mA	L=4.7uh(power inductor) C=10uf D=1N5819

Power Supply Voltage and Load Capability with Resistor Mode Device Configuration

Supply Voltage	Load Capability	Device Configuration
12V	15mA	R=100Ω (1206 package) C=10uf
24V	20mA	R=100Ω (1206 package) C=10uf
12V	25mA	R=51Ω (1206 package) C=10uf
24V	35mA	R=51Ω (1206 package) C=10uf
12V	70mA	R=10Ω (1206 package) C=10uf
24V	70mA	R=10Ω (1206 package) C=10uf

Preventing Power-On Crosstalk

During power-up, especially in hot-swap operations, the gate voltage of the power MOSFET can be coupled to a high voltage due to the Miller capacitance (as shown in the left diagram below). If the voltage exceeds the MOSFET's conduction threshold, the MOSFET may erroneously conduct, leading to potential damage. The ZH6350 is designed with logic to prevent power-on misconduction (as shown in the right diagram below), ensuring that the chip and the power MOSFET are not damaged during rapid power-up.

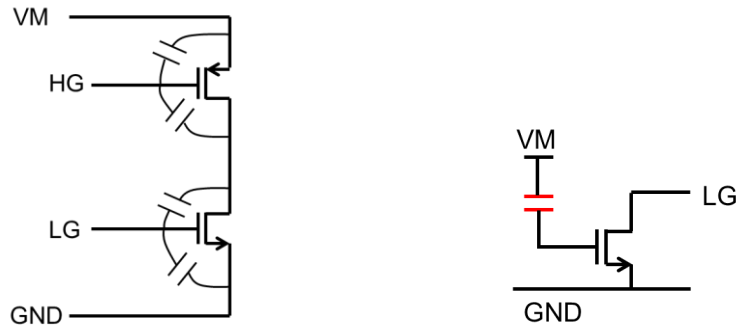

Preventing Logic Crosstalk

If both Lix and Hix are 1 simultaneously, both the upper and lower outputs will be turned off to prevent crosstalk.

Adaptive Dead Time

In different load power MOSFETs, working voltages, and operating temperatures, the rise and fall times of the gate voltage can vary. Traditional methods of generating dead time use a fixed dead time, which cannot adapt to these parameter changes. This results in wasted dead time during light loads, causing output waveform distortion, and insufficient dead time during heavy loads, potentially causing crosstalk between the upper and lower MOSFETs.

The ZH6350 employs feedback-based adaptive dead time control. The driver chip continuously monitors the upper MOSFET's status during its turn-off process. Once the turn-off is fully completed, it signals the lower MOSFET's drive to turn on. Similarly, during the lower MOSFET's turn-off process, the driver chip continuously monitors its status and signals the upper MOSFET's drive to turn on once the turn-off is fully completed. This design minimizes dead time width while ensuring safety.

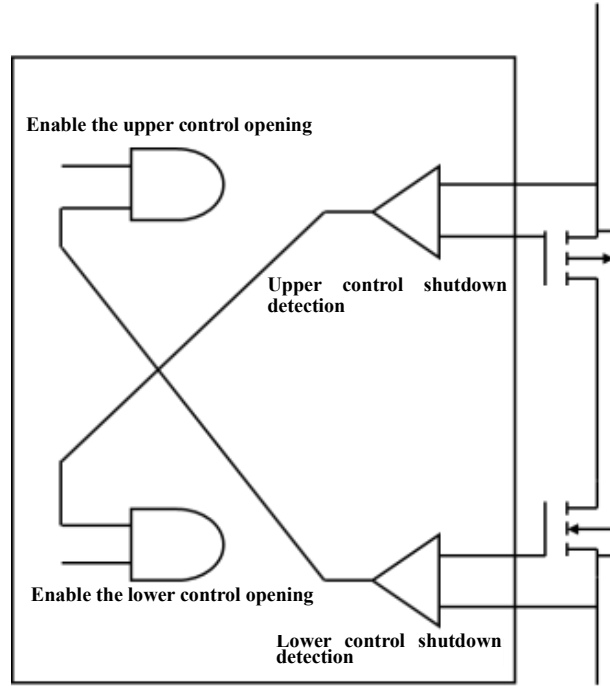

Package Dimensions

SOP-16

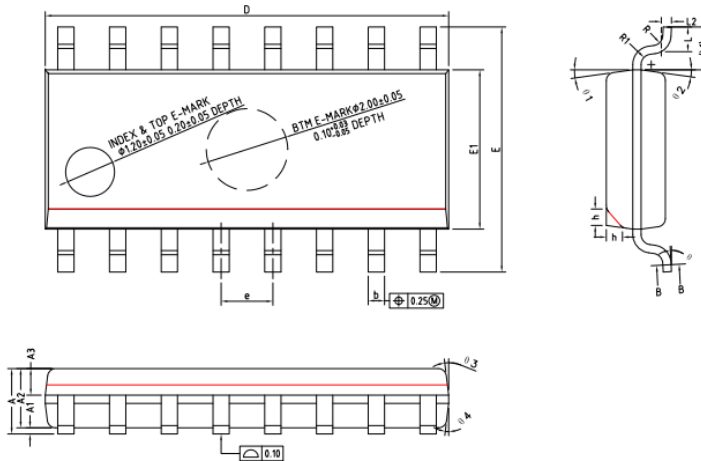

COMMON DIMENSIONS
(UNITS OF MEASURE=MILLIMETER)

SYMBOL	MIN	NOM	MAX
A	-	-	1.75
A1	0.10	0.15	0.25
A2	1.35	1.45	1.55
A3	0.55	0.65	0.75
b	0.36	-	0.51
b1	0.35	0.40	0.45
c	0.18	-	0.25
c1	0.17	0.20	0.23
D	9.80	9.90	10.00
E	5.80	6.00	6.20
E1	3.80	3.90	4.00
e	1.22	1.27	1.32
L	0.45	0.60	0.80
L1	1.04REF		
L2	0.25BSC		
R	0.07	-	-
R1	0.07	-	-
h	0.30	0.40	0.50
l	0'	-	8'
l 1	6'	8'	10'
l 2	6'	8'	10'
l 3	5'	7'	9'
l 4	5'	7'	9'

QFN-16

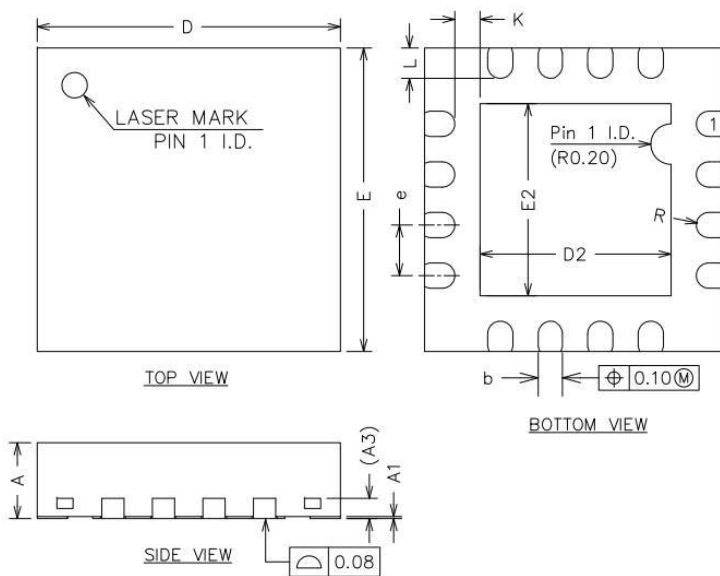

COMMON DIMENSIONS
(UNITS OF MEASURE=MILLIMETER)

SYMBOL	MIN	NOM	MAX
A	0.70	0.75	0.80
A1	0.00	0.02	0.05
A3	0.20REF		
b	0.20	0.25	0.30
D	2.90	3.00	3.10
E	2.90	3.00	3.10
D2	1.80	1.90	2.00
E2	1.80	1.90	2.00
e	0.40	0.50	0.60
K	0.15	0.25	0.35
L	0.20	0.30	0.40
R	0.10	-	-

NOTES:
ALL DIMENSIONS DO NOT INCLUDE MOLD FLASH
OR PROTRUSION.

Revision History

Version	Modification Date	Modification Details
V1.4	2024.06.18	Generates the English Version Datasheet.

单击下面可查看定价，库存，交付和生命周期等信息

[>>Semiment \(赛卓电子\)](#)