High Speed 12-Bit Magnetic Rotary Encoder

FEATURES

- Contactless 12-bit resolution rotational encoder
- Programmable resolution, pole-pairs and zero position
- 12-bit absolute outputs
 - SPI interface
 - PWM interface
- Incremental outputs
 - A/B/Z interface (Up to 1024 wires)
 - U/V/W interface (1~16 pairs of pole)
 - A+/B+/Z+ and A-/B-/Z- differential output
- Angle linearity error $< \pm 0.35^\circ$
- Maximum tracking speed: 20Krpm
- Wide temperature range: -40°C to 125°C
- SSOP16 package

APPLICATIONS

- Contactless rotary position sensing
- Brushless DC motor commutation
- Robotics
- Angular encoder
- Rotational speed control

DESCRIPTION

SC60224 is a contactless high-speed, high-precision magnetic encoder chip. Hall induction point matrix is built into the center of the chip, which generates sine and cosine position signals by sensing a pair of pole magnets above. The analog to digital conversion circuit inside the chip samples the amplified sine and cosine signals, and the DSP circuit performs Angle calculation, and finally outputs various position signals. SC60224 has a resolution of 12 bits, and each circle can generate 4096 incremental Angle signals. The position of zero signals can be programmed through SPI interface, and the maximum support is 20K RPM.

SC60224 uses 16-pin SSOP package, matte tin plating, halogen-free green material, to meet the environmental requirements.

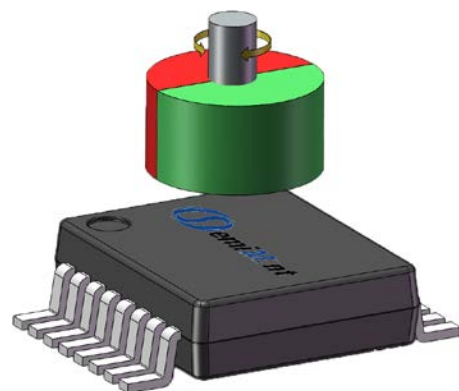

CONTENTS

FEATURES	1 -	FUNCTIONAL DESCRIPTION	8 -
APPLICATIONS	1 -	Position of the Hall Sensors	8 -
DESCRIPTION	1 -	SPI Interface (SC60224-U).....	9 -
BLOCK DIAGRAM	3 -	Incremental Outputs.....	10 -
ORDERING INFORMATION	3 -	UVW Commutation Mode (SC60224-U)	11 -
TERMINAL CONFIGURATION	4 -	Pulse Width Modulation Output.....	12 -
ABSOLUTE MAXIMUM RATINGS	5 -	TYPICAL APPLICATION	13 -
ESD Protection	5 -	PACKAGE INFORMATION	14 -
OPERATING CHARACTERISTICS	6 -	Revision History	15 -
OPERATING CHARACTERISTICS(continued)	7 -		

BLOCK DIAGRAM

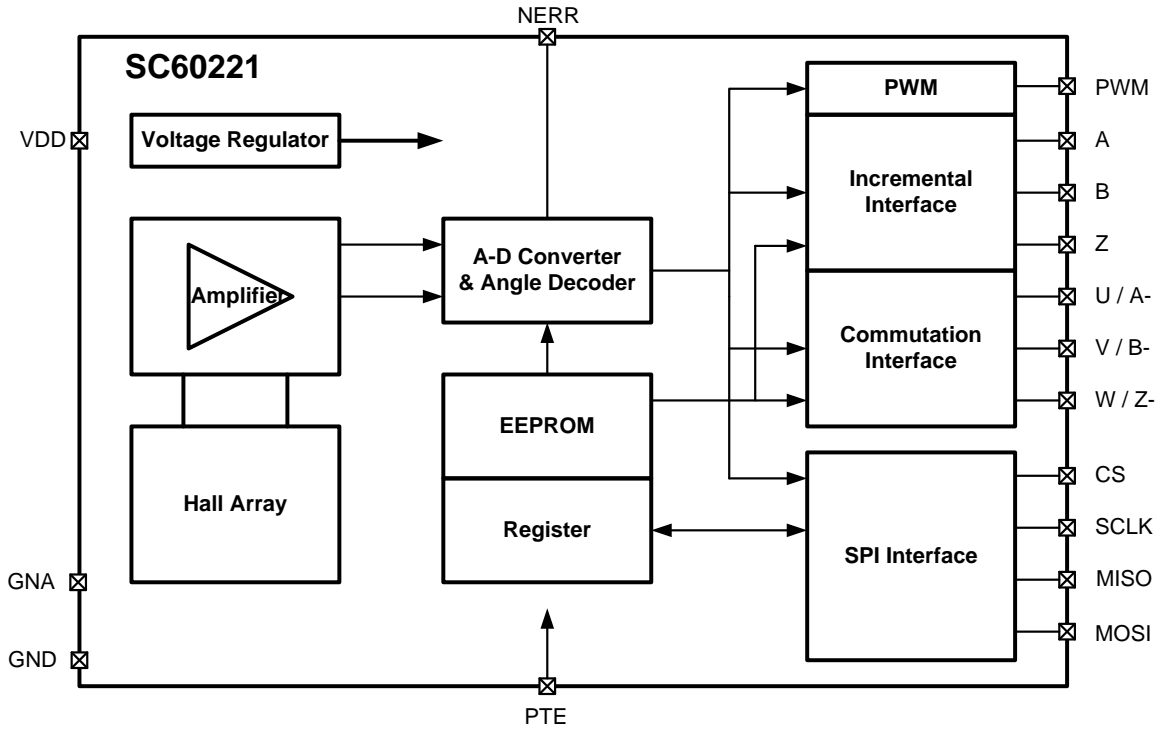

ORDERING INFORMATION

Part Number	Packing	Mounting	Output Type	Marking
SC60224-U	80 pcs Tube	16-pin SSOP	A, B, Z, U, V, W; SPI; PWM	60224
SC60224-D	80 pcs Tube	16-pin SSOP	A+, B+, Z+, A-, B-, Z-; SSI; PWM	60224-D

SC60224-D-P4-1000

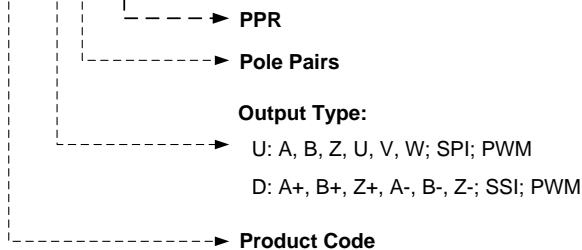

Eg: SC60224-U-P4-1024:

1024 PPR, 4 pole pairs and with A, B, Z, U, V, W and SPI, PWM outputs.

TERMINAL CONFIGURATION

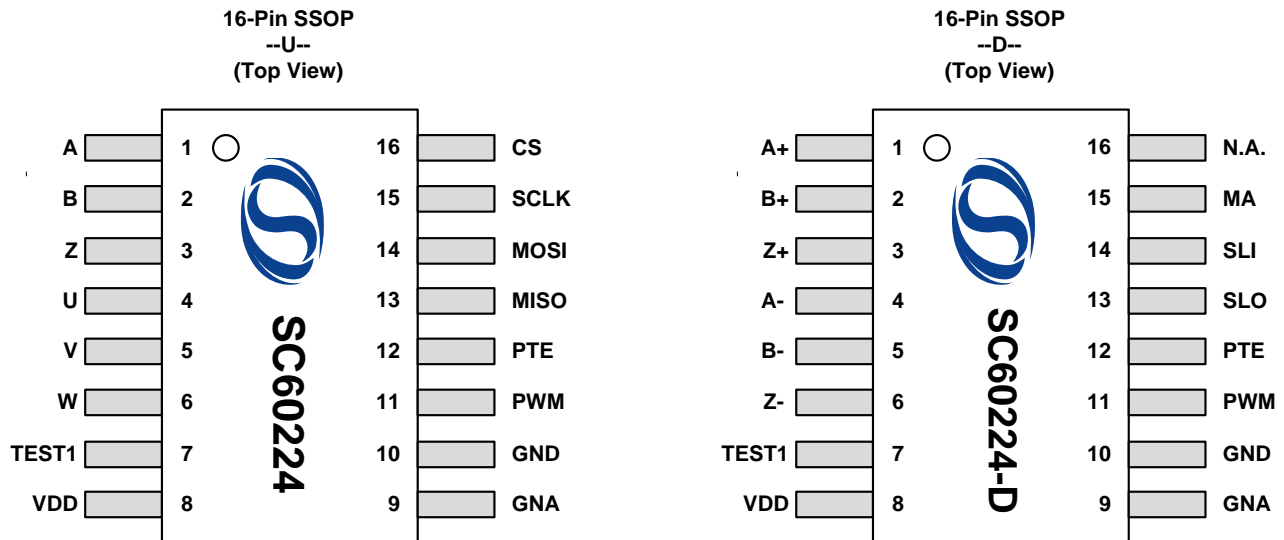

No.	Pin Name		I/O	Type	Description
	SC60224-U	SC60224-D			
1	A	A+	Output	Digital	A phase Pulse Signal
2	B	B+	Output	Digital	B phase Pulse Signal
3	Z	Z+	Output	Digital	C phase Pulse Signal
4	U	A-	Output	Digital	U/A- phase Pulse Signal
5	V	B-	Output	Digital	V/B- phase Pulse Signal
6	W	Z-	Output	Digital	W/Z- phase Pulse Signal
7	NERR	NERR	Output	Digital	Error output (active low)
8	VDD	VDD	-	Power	Power Supply PIN
9	GNA	GNA	-	GND	Analog Ground PIN
10	GND	GND	-	GND	Digital Ground PIN
11	PWM	PWM	Output	Digital	PWM Pulse Output PIN
12	PTE	PTE	Input	Digital	EEPROM Programming Protection PIN
13	MISO	MISO	Output	Digital	SPI Output Data Signal
14	MOSI	MOSI	Input	Digital	SPI Input Data Signal
15	SCLK	SCLK	Input	Digital	SPI Clock Signal
16	CS	CS	Input	Digital	SPI Chip Select Signal

ABSOLUTE MAXIMUM RATINGS

Characteristic	Symbol	Notes	Min.	Max.	Unit
Voltage at VDD A, B, Z, U, V, W, MOSI, MISO, SCLK, CS, NERR	V()		-0.3	6	V
Current in VDD	I()		-10	20	mA
Current at A, B, Z, U, V, W, MISO, NERR	I()		-100	100	mA
Current at SCLK, CS, MOSI, PTE	I()		-10	10	mA
EEPROM Write Cycles				100	cycle
Operating ambient temperature	T _A		-40	125	°C
Storage temperature	T _{STG}		-65	165	°C
Operating junction temperature	T _{J(max)}			165	°C

Note: Stresses above those listed here may cause permanent damage to the device. Exposure to absolute maximum rating conditions for extended periods may affect device reliability.

ESD Protection

Human Body Model (HBM) tests according to: standard EIA/JESD22-A114-B HBM

Parameter	Symbol	Limit Values		Units
		Min.	Max.	
ESD-Protection	V _{ESD}	-4	4	KV

OPERATING CHARACTERISTICS

valid through the full operate temperature range, VDD=5V, CBY=0.1uF, unless otherwise specified

Parameter	Symbol	Test Conditions	Min.	Typ.	Max.	Unit
Electrical Characteristics						
Supply Voltage	V _{DD}		3.0	5.0	5.5	V
Supply Current	I _{DD}	No load, fmag=0 rpm	10	16	22	mA
Bandgap Reference	V _{bg}		1.18	1.25	1.32	V
Reference voltage	V _{ref}		45	50	55	%VDD
Turn-on Threshold	V _{th(on)}	Increasing voltage	2.6	2.75	2.9	V
Turn-off Threshold	V _{th(off)}	Decreasing voltage	2.4	2.6	2.8	V
Hysteresis	V _{th(Hys)}		0.15			V
Reference Voltage Offset	V _{R(offset)}		470	500	530	mV
Clock Generation						
System Clock	f(sys)	Bias current adjusted	0.8	1	1.2	MHz
AD Converter Frequency	f(sdc)	Bias current adjusted	13	16	19	MHz
Sine/Digital Converter						
Sine/Digital Converter Resolution	RES _(sdc)			12		bit
Integral non-linearity	INL _{opt}	VDD=5V, Temp=25°C, Din=1.0mm	-0.5		0.5	Deg
Integral non-linearity	INL _{temp}	Maximum error with respect to the best line fit, Tamb=-40 to 125°C	-0.9		0.9	Deg
Relative Angular Accuracy	AA(rel)	With reference to an output period at A, B	-20	0	+20	%
Angle Output Delay Time	TD	at ABZ hysteresis = "1LSB"		18.0	45.0	uS
Signal Level Control						
Differential Peak-to-Peak Output Amplitude	V _{pp}		3.2	4.0	4.8	V
Controller Setting Time	t(on)	to ± 10% of final amplitude			300	uS
Min. Amplitude error	Vt(lo)		1.0		2.8	V
Max. Amplitude error	Vt(hi)		4.8		5.8	V
PWM Output						
PWM frequency (default)	F(pwm)	VDD=5V, Temp=25°C	927	976	1024	Hz
PWM frequency (optional)	F(pwm)	VDD=5V, Temp=25°C	232	244	256	Hz

OPERATING CHARACTERISTICS(continued)

valid through the full operate temperature range, VDD=5V, CBY=0.1uF, unless otherwise specified

Parameter	Symbol	Test Conditions	Min.	Typ.	Max.	Unit
Magnetic Input Specification						
Diameter	dmag	φ 6mm x 2.5mm for cylindrica Magnets	4.0	6.0	10.0	mm
Thickness	tmag			2.5		mm
Installation Distance	Din	Recommended magnets		1.0	2.0	mm
Field Amplitude	Hext	At chip surface	25		125	mT
Rotation Frequency	f(mag)				333	Hz
Rotating Speed of Magnet	rpm				10	krpm
Lateral Displacement of Magnet Axis to Center of Hall Sensors	xdis				0.2	mm
Displacement Chip Center to Package Center	xpac		-0.15		0.15	mm
Angular Alignment of Chip vs. Package	φ pac		-3		3	Deg
Displacement of Chip Surface to Package Surface	hpac			0.4		mm
Digital Inputs:CS,SCLK,MOSI						
Threshold Voltage hi	Vt()hi				2	V
Threshold Voltage lo	Vt()lo		0.8			V
Pull-down Current MOSI	l _{pd} ()	V() = 1 V...VPD	6	38	60	uA
Pull-up Current Source at CS,SCLK	l _{pu} ()	V() = 0...VPD - 1 V	-80	-140	-200	uA
Digital Inputs:PTE						
Drop-down current PTE	l _{pd} ()	V() = 1 V...VPD	1	4	10	uA
Open the threshold	PTEon			1.7		V
Close the threshold	PTEoff			1.3		V
Digital OUTPUTS:A,B,Z,U,V,W,PWM,MISO,NERR						
Saturation Voltage hi	V _s ()hi	I()hi = -4 mA, with reference to VDD			200	mV
Saturation Voltage lo	V _s ()lo	I()lo = 4 mA, with reference to GND			200	mV
Short-Circuit Current hi	I _{short} ()hi	V() = GND;	10		20	mA
Short-Circuit Current lo	I _{short} ()lo	V() = VDD;	5		15	mA
Rise-Time lo to hi	t _{Rise}	R _L = 100 Ω to GND;	5		30	nS
Fall-Time high to lo	t _{Fall}	R _L = 100 Ω to VDD;	5		30	nS

FUNCTIONAL DESCRIPTION

Position of the Hall Sensors

The Hall sensors are placed in the center of the package at a 90° angle to one another and arranged in a circle.

The zero-angle position of the magnet is reached when the value of $V_{PCOS} - V_{NCOS}$ is at a maximum. This is the case when the South Pole of the magnet is exactly above the PCOS sensor and the North Pole is above sensor NCOS. When the magnet is rotated counterclockwise, the angle is increasing, as shown in the figure below.

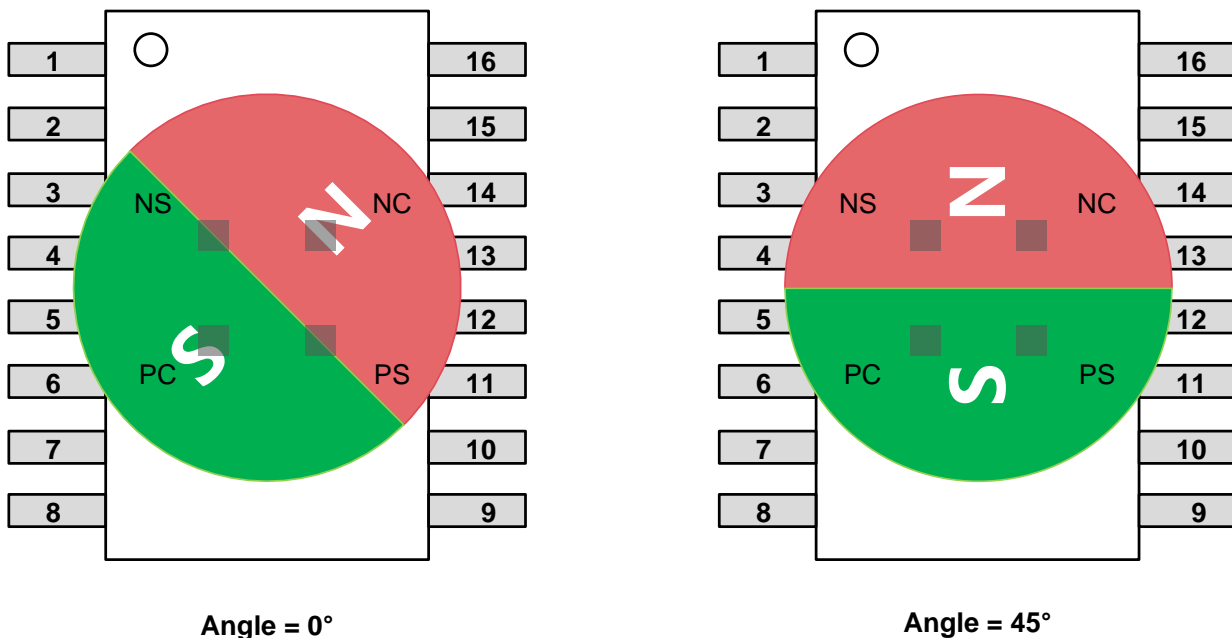

SPI Interface (SC60224-U)

Serial Peripheral Interface Timing Diagram with Absolute Angular Position Data

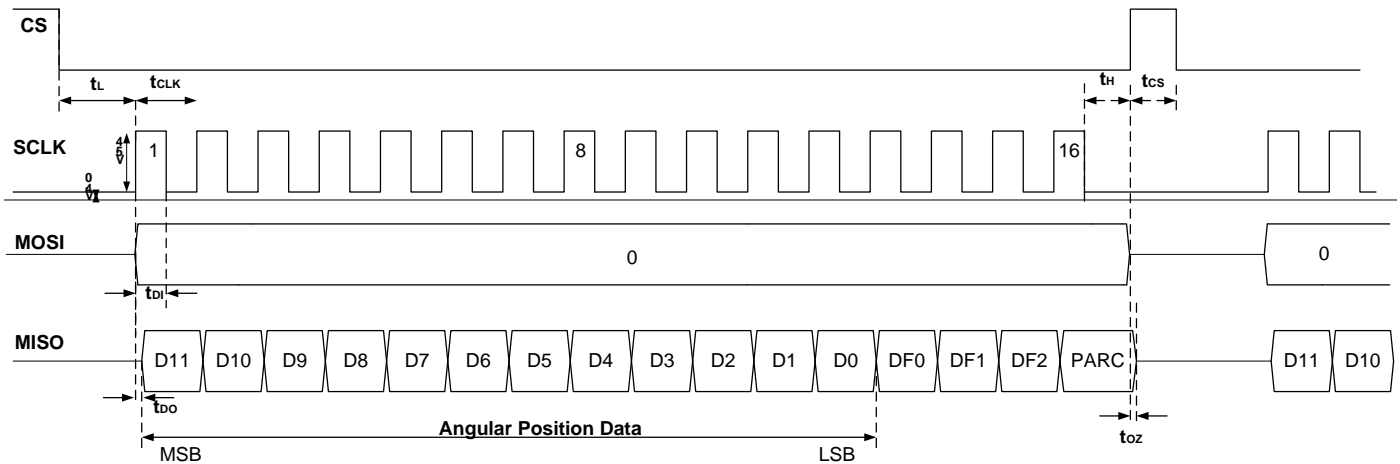

SPI Timing Definition

Parameter	Description	Min.	Max.	Units
t_L	Time between CS falling edge and SCLK rising edge	250		ns
t_{CLK}	Serial clk period	100		ns
t_H	Time between last falling edge of SCLK and rising edge of CS	$t_{CLK}/2$		ns
t_{CS}	High time of CS between two transmissions	250		ns
t_{DO}	SCLK edge to data output valid		50	ns
t_{DI}	Data input valid to falling clock edge	20		ns
t_{OZ}	Release bus time after CS rising edge		10	ns

SPI Read Data Frame

Bit	Name	Description
15	PARC	Parity bit (odd) calculated on the lower 15 bits of data frame
14	DF2	Data fixed; logic High
13	DF1	Data fixed; logic High
12	ERR	Becomes logic High, when the fault occurs
11:0	DATA	Absolute angular position data (MSB is clocked out first)

Incremental Outputs

The SC60224 provides the ABZ incremental output via A, B, Z pin. These outputs are encoded from the angle output data. When the magnet is rotating in counter-clockwise at default settings, the B-phase leads the A-phase.

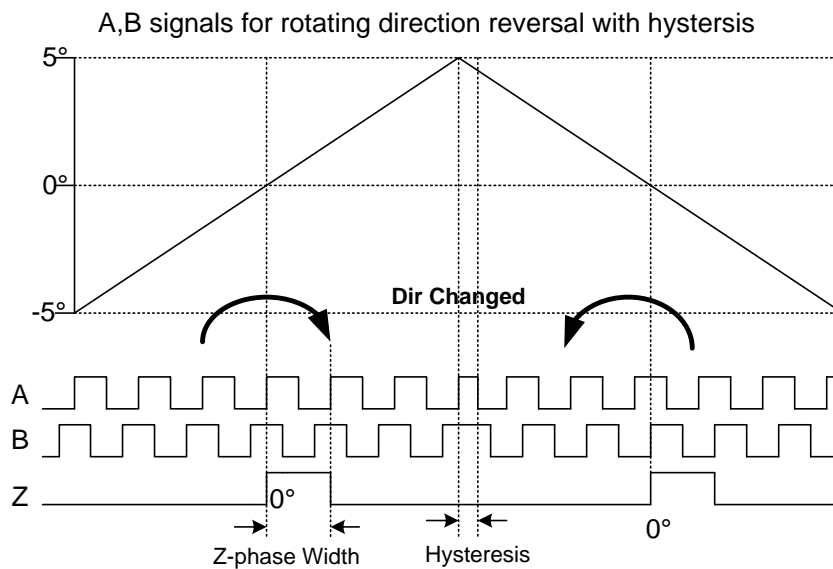

The **Z-phase width** is programmable between 1LSB, 2LSB, 4LSB (default) and 8LSB

ABZ Resolution Setting			
No.	Type	Pulses per Round	Counts per Revolution
1	Binary	1024	4096
2		512	2048
3		256	1024
4		128	512
5		64	256
6	Decimal	1000	4000
7		800	3200
8		600	2400
9		500	2000
10		400	1600
11		360	1440
12		300	1200
13		200	800
14		100	400
15		50	200

The **ABZ Hysteresis** is programmable between 0LSB, 2LSB, 4LSB (default) and 8LSB

UVW Commutation Mode (SC60224-U)

The SC60224 provides UVW commutation output necessary for detecting the magnetic pole of the DC brushless motor via U, V, and W pin. The phase of each output is shifted by electric angle phase 120°. The output resolution is programmable from 1 to 16 pole pairs.

One-pole-pair

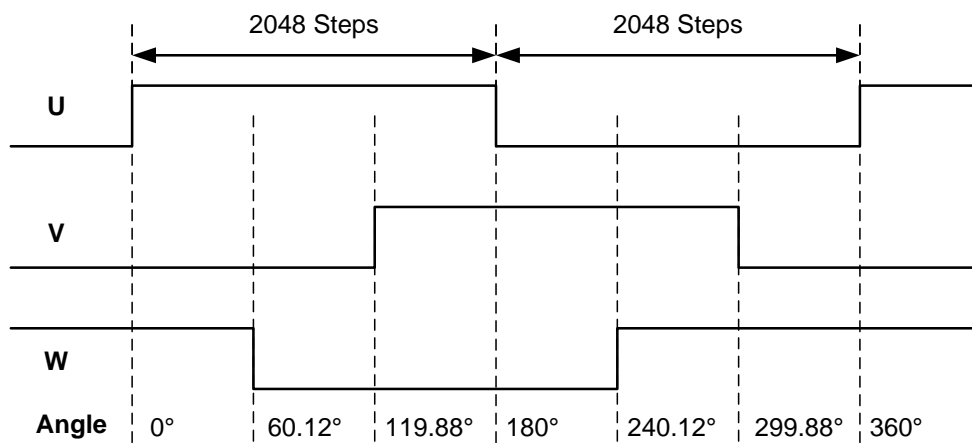

Two-pole-pair

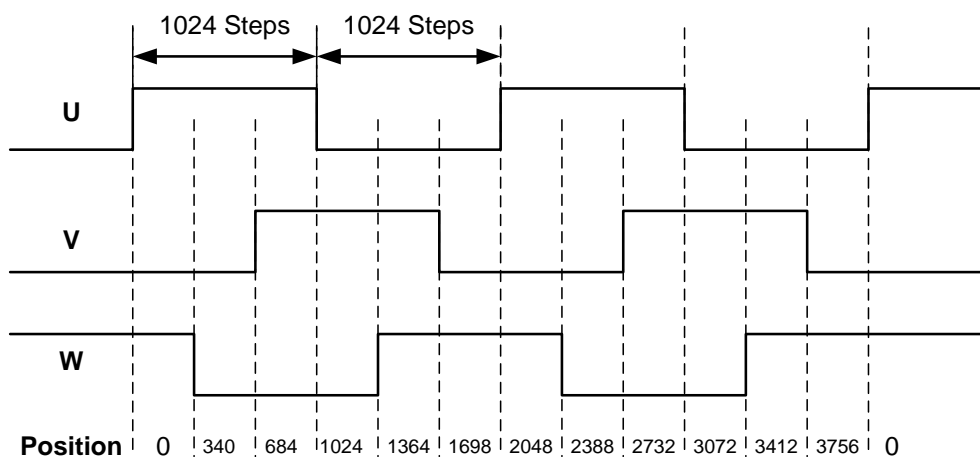

Pulse Width Modulation Output

The SC60224 provides a pulse width modulated output (PWM), whose duty cycle is proportional to the measured angle.

$$\text{Position} = t_{on} \times 4098 / (t_{on} + t_{off}) - 1$$

The PWM frequency is internally trimmed to an accuracy of $\pm 5\%$ ($\pm 10\%$ over full temperature range). This tolerance can be canceled by measuring the complete duty cycle as shown below:

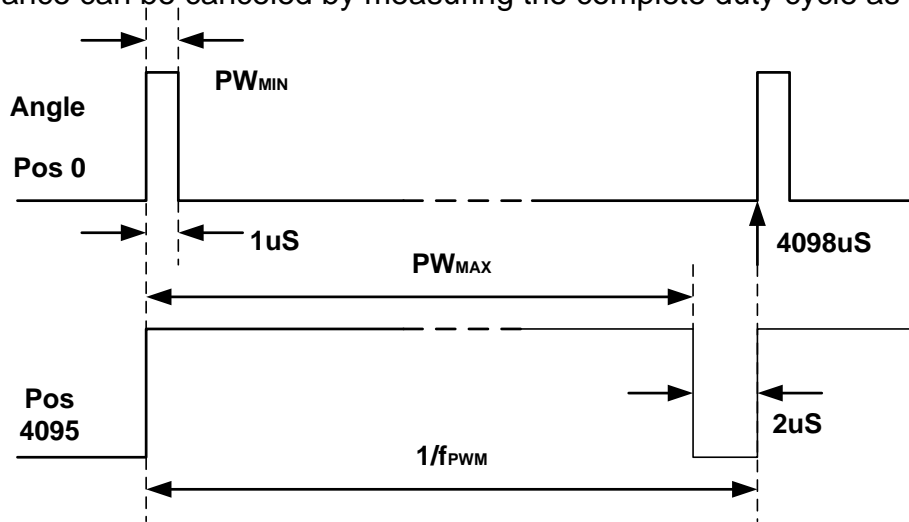

Schematic diagram of waveform with PWM frequency of 244Hz

PWM default frequency (976Hz)

Parameter	Symbol	Typ.	Unit	Note
PWM frequency	f _{PWM}	976	kHz	Signal period: 4098uS
MIN pulse width	PW _{MIN}	0.25	uS	Position 0d
Max pulse width	PW _{MAX}	1024	uS	Position 4095d

PWM optional frequency (244Hz)

Parameter	Symbol	Typ.	Unit	Note
PWM frequency	f _{PWM}	244	kHz	Signal period: 4098uS
MIN pulse width	PW _{MIN}	1	uS	Position 0d
Max pulse width	PW _{MAX}	4096	uS	Position 4095d

TYPICAL APPLICATION

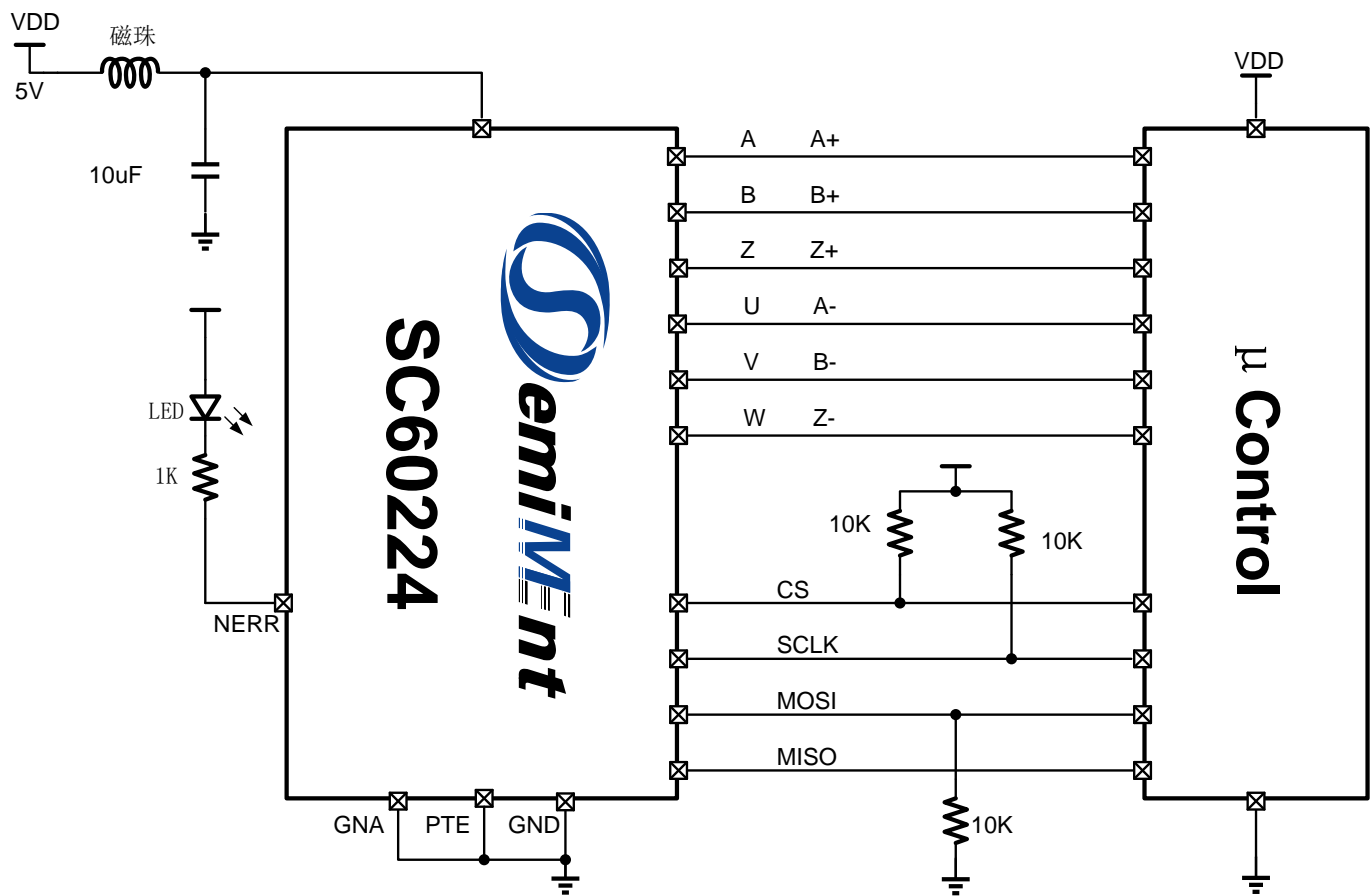

Remark:

1. Add SMD inductor (magnetic bead) and 10uF decoupling capacitor to power end of magnetic encoder chip.
2. CS and SCLK end plus 10K pull-up resistor, MOSI plus 10K pull-down resistor.
3. Since SPI communication is a board-level communication protocol, it is recommended that the length of the connection line should not exceed 30cm if communication is required via wire connection.
4. If ABZUVW is connected to the controller end, please use RS422 differential communication chip 26C31 for differential signal transmission in long line communication.

PACKAGE INFORMATION

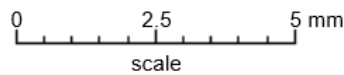
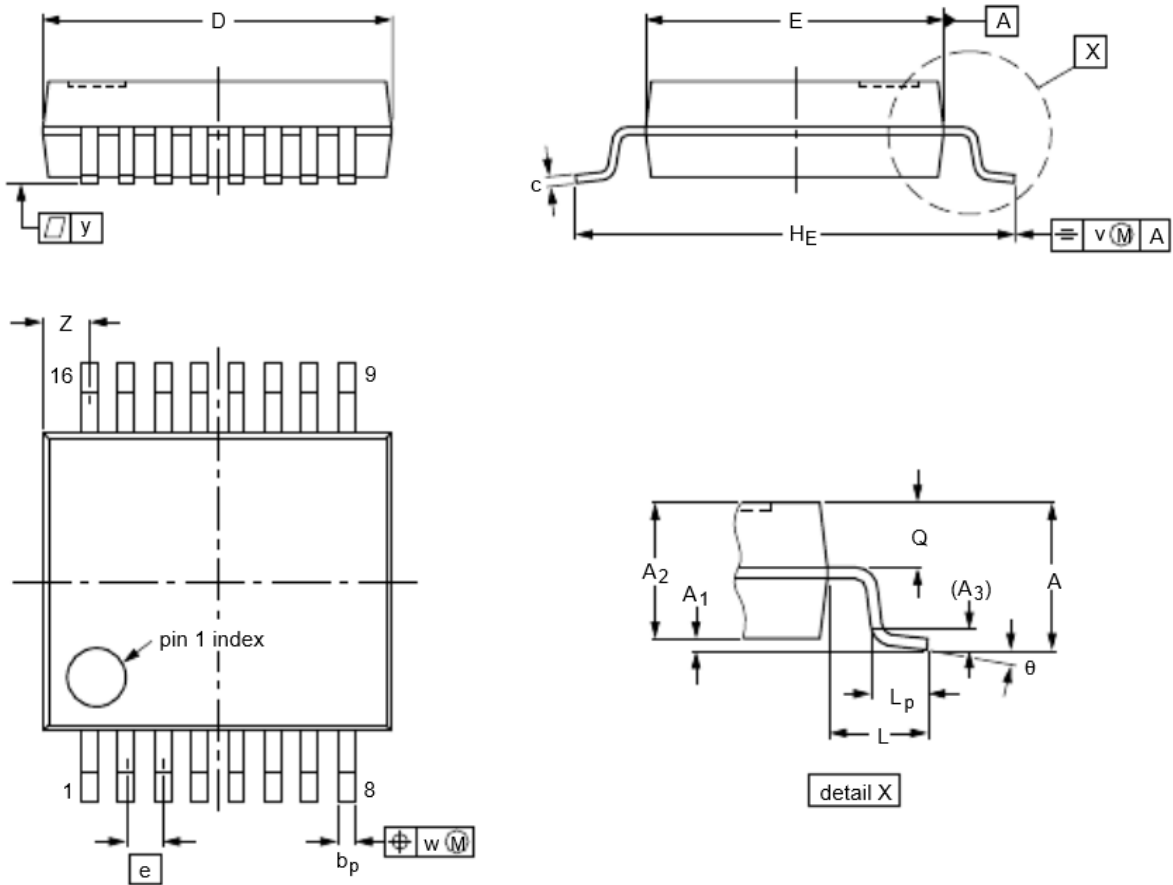

DIMENSIONS (mm are the original dimensions)

UNIT	A	A ₁	A ₂	A ₃	b _p	c	D ⁽¹⁾	E ⁽¹⁾	e	H _E	L	L _P	Q	v	w	y	Z ⁽¹⁾	θ
mm	2	0.21	1.80	0.25	0.38	0.20	6.4	5.4	0.65	7.9	1.25	1.03	0.9	0.2	0.13	0.1	1.00	8
		0.05	1.65		0.25	0.09	6.0	5.2		7.6		0.63	0.7					0.55

Note

1. Plastic or metal protrusions of 0.25mm maximum per side are not included.

Revision History

Date	Revision	Description
Apr 4,2019	RevA1.0	Initial release
Jul 16,2019	RevA1.1	Update typical application circuit
May 31,2020	RevA1.2	Add version history
Nov,17 2020	RevA/1.0	Update format

单击下面可查看定价，库存，交付和生命周期等信息

[>>Semiment \(赛卓电子\)](#)