

Up to 65A, High-precision current sensor chip that With stands surge currents up to 8KA

Description

SC820 is a chip type current sensor with wide isolation distance and high current capacity developed by Senko micro. This product in 10.3mm*10.4mm*2.3mm wide-body SOP16 encapsulation on realized as low as 0.6mΩ current lead impedance, this enables it to be applied to power systems requiring continuous operation at measurements up to 65A.

SC820 series is an isolated current detection chip that uses the principle of open-loop Hall sensor detection. By introducing the current wire on the high-voltage side into the package, based on the magnetic effect of the current, the amount of iso-magnetic field generated around the wire under test is induced by the magnetic sensor of the built-in chip and converted to a treatable ethonal-voltage signal, which is amplified by the built-in high-precision ADC reading, with digital calibration technology, to remove environmental variables such as temperature, noise, hysteresis, nonlinearity, and finally the voltage value of the current under test is nearly ideal.

SC820 adopts automatic production and processing, can bring customers incomparable consistency, high quality and high reliability of module technology. Standard package design is very suitable for customers to carry out batch automatic patch production, which is the best solution for photovoltaic inverter, household appliances, charging pile.

Senko Micro is committed to the research of core chip technology, with the aim of bringing customers the best current detection solution.

Features

- 4.8kV RMS minimum isolation voltage
- Output voltage proportional to AC or DC currents
- Lowest Current conductor impedance: 0.6mΩ
- 13kA 8/20uS Surge isolation current
- Support Viout-Vref differential output mode
- Internal reference voltage
- $3\mu\text{s}$ output rise time in response to step input current
- Operating temperature range: -40°C~125°C
- Range of measured current:20A~65A
- Total output error<1% @T_A=25°C, <3% for full temperature range
- Strong driving ability
- Extremely simple peripheral circuit
- Built-in AC zero-crossing detection function
- Support wave soldering full-automatic patch and tape packaging
- It is not interfered by wire magnetic field, external magnetic field and geomagnetic field
- High PSRR
- Independent copyright of Senko Micro



Package

Top View:



Current Path view:



Typical Application

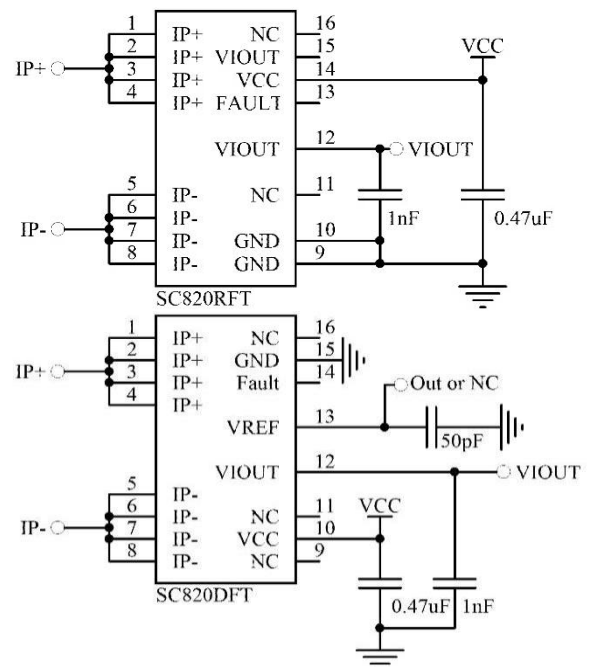

Order information (Marking products: Not intended for sample applications)

Part Number	Special Code	Temp.Range	Packing	IP(A) *3	Vout@IP=0A ¹	Sens@VCC=5V(mv/A)
SC820RFT-20B5	R (no reference)	F(-40~125°C)	T (Reel, 1500 pieces/reel)	± 20	B(0.5Vcc)	100
SC820RGT-22F5				± 22.22	F(2.5)	90
SC820RFT-25B5				± 25	B(0.5Vcc)	80
SC820RFT-30B5				± 30		66
SC820RFT-50B5				± 50		40
SC820RFT-40F5				± 40	F(2.5)	50
SC820RFT-50F5				± 50		40
SC820RGT-52F5				± 51.95	F(2.5)	38.5
SC820RFT-65B5				± 65	B(0.5Vcc)	30.75
SC820RGT-98F5				± 97.56	F(2.5)	20.5
SC820NFT-25F5	N (With reference, but the driving ability is weak and the difference error is large)	F(-40~125°C)	T (Reel, 1500 pieces/reel)	± 25	F(2.5)	80
SC820NFT-30B5				± 30	B(0.5Vcc)	66
SC820NFT-40B5				± 40		50
SC820NFT-50F5				± 50	F(2.5)	40
SC820NFT-65B5				± 65	B(0.5Vcc)	30.75
SC820DFT-20F5	D	F(-40~125°C)	T (Reel, 1500 pieces/reel)	± 20	F(2.5)	100
SC820DFT-30F5				± 30		66
SC820DFT-50F5				± 50		40
SC820DFT-65F5				± 65		30.75
SC820DFT-20U5				20		U(0.1Vcc)

Note 1: F, B, U are different in the reference output when IP=0A, F is recommended by default.

F	when IP=0A, VIOU@0A=VREF=2.5V, suitable for bidirectional current detection, Zero Current voltage and sensitivity is fixed
B	when IP=0A, VIOU@0A=0.5*VCC, suitable for bidirectional current detection, Zero Current Output and sensitivity vary with VCC ratio
U*2,3	when IP=0A, VIOU@0A=0.1*VCC, suitable for unidirectional current detection, Zero Current Output and sensitivity vary with VCC ratio

Note 2: Model U, dynamic range x2, sensitivity x2; if there is any other sensitivity requirement, can connect our FAE or agent.

Note 3: Model U, is sample at present.

Pin Configuration

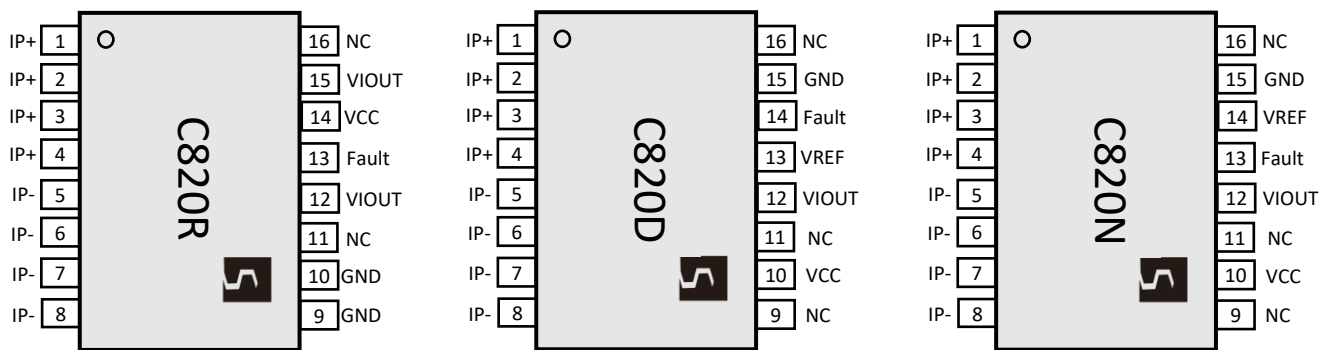

Pin of 820RFT	Pin of 820DFT	Pin of 820NFT	Pin Name	Description
1/2/3/4	1/2/3/4	1/2/3/4	IP+	The primary current is input to the positive terminal
5/6/7/8	5/6/7/8	5/6/7/8	IP-	The primary current is output to the negative terminal
9/10	15	15	GND	Signal Ground terminal
12/15	12	12	VIOUT	Analog output signal. VIOUT=IP*Sens+Vref
14	10	10	VCC	Device power supply
	13	14	VREF	Internal or External output: Equal to Vout@IP=0A
13	14	13	VFault	Over current Fault pin. When current flowing between IP+ pins and IP- pins exceeds the overcurrent fault threshold, this pin transitions to a logic low state.

Thermal Rise vs. Primary Current

Typical Plastic package temperature[°C] of SC820 vs Primary current [A] based on Demo Board

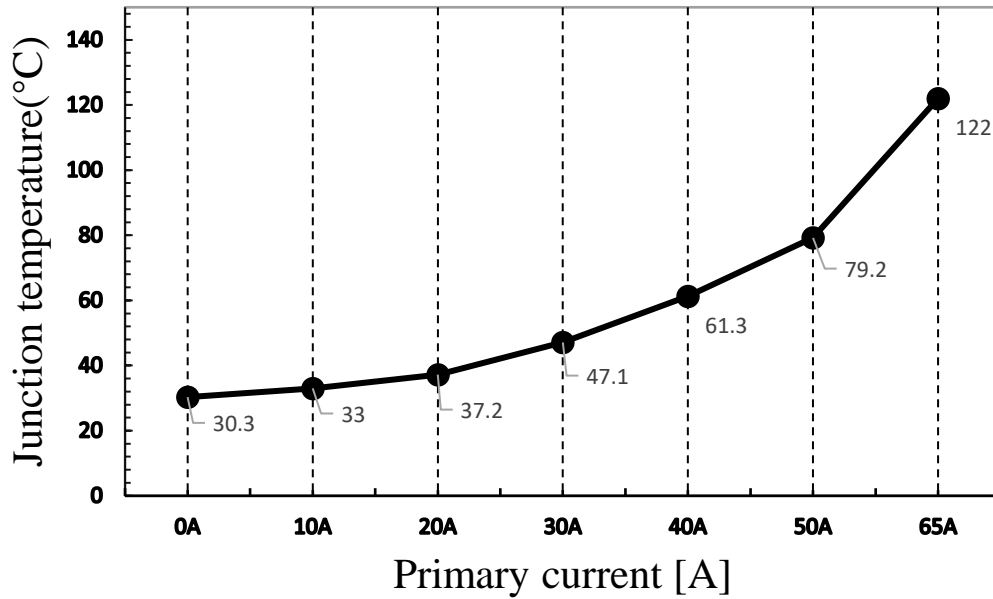

Demo Board information

Parameter	Units
Layer Number	2
Copper layer thickness	4 Oz
Total Copper size connected to Primary pins(including all layers)	1520mm ²
Board Thickness	1.6mm

Functional Block Diagram

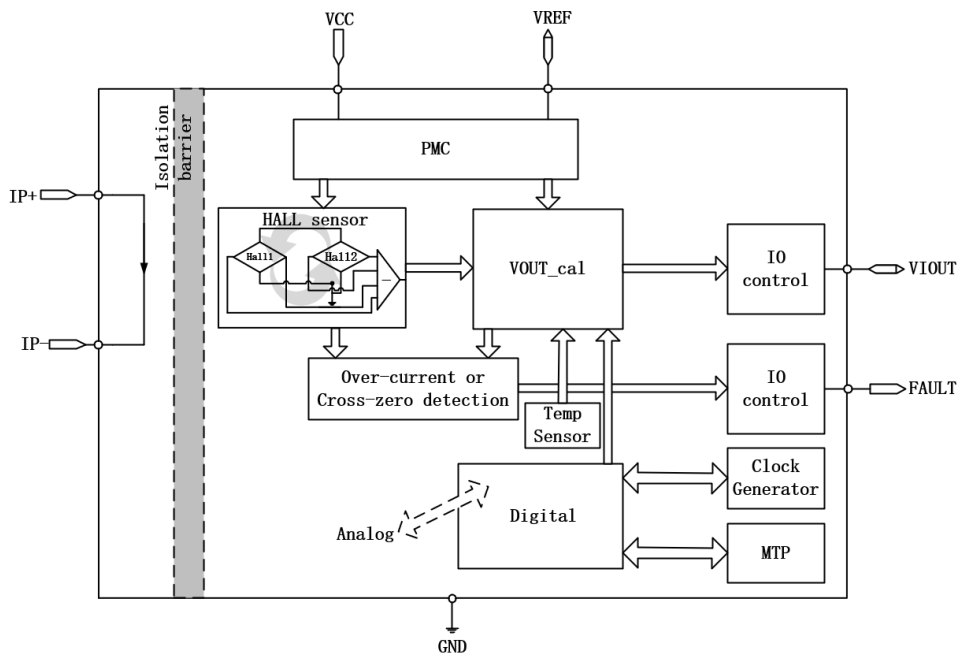

Absolute Maximum Ratings

Absolute maximum ratings are limiting values to be applied individually, and beyond which the serviceability of the circuit may be impaired. Functional operability is not necessarily implied. Exposure to absolute maximum rating conditions for an extended period of time may affect device reliability.

Characteristic	Symbol	Notes	Rating	Unit
Supply voltage	V _{CC}		6.0	V
Reverse Supply Voltage	V _{RCC}		-0.1	V
Output Voltage	V _{IOUT}		6.0	V
Reverse Output Voltage	V _{RIOUT}		-0.1	V
Nominal Operating Ambient Temperature	T _A	Range F	-40~125	°C
		Range E	-40~85	
Maximum Junction Temperature	T _{J(max)}		165	°C
Storage Temperature	T _{stg}		-65~165	°C
Output Current Source	I _{OUT(Source)}	Shorted Output-to-Ground Current	4.5	mA
Output Current Sink	I _{OUT(Sink)}	Shorted Output-to-VCC Current	40	mA
Vref Current Source	I _{REF(Source)}	Shorted Vref-to-Ground Current	4	mA
Vref Current Sink	I _{REF(Sink)}	Shorted Vref-to-VCC Current	40	mA
Overcurrent Fault Output Pin Resistance	R _{vfault}	Pull-up Voltage under VCC is not allowed	2	kΩ
The Pull-up Voltage Of Vfault	V _{CCfault}	Open drain output, Connected to VCC is allowed	8	V
Maximum Continuing IP Current	I _{Pmax}	Based on Senko's Demo Test Board	65	A
Transient Over Current At Ambient Temperature	I _{POver}	Based on Senko's Demo Test Board , 1pulse , 100ms , 1% Duty Cycle	125	A
HBM mode	ESD		4	kV

Isolation Characteristics

Parameter	Symbol	Value	Unit	Comment
RMS voltage for AC insulation test, 50Hz, 1min	V _{ISO}	4800	V _{rms}	Agency type-tested for 60 seconds per UL60950-1
Working Voltage for Basic Isolation	V _{WVRI}	1550	V _{Peak}	Maximum working voltage according to UL60950-1
Clearance	D _{cl}	8.2	mm	Minimum distance through air from IP leads to signal leads
Creepage distance	D _{cr}	8.2	mm	Minimum distance along package body from IP leads to signal leads
Comparative trackong index	CTI	600	V	the electrical breakdown (tracking) properties of an insulating material
Maximum surge isolation voltage	V _{IOSM}	10	kV	V _{TEST} =1.3 x V _{IOTM} =13000V _{PK} , 1.2/50us waveform
Maximum Transient impulse current	I _{IOSM}	13	kA	I _{TEST} =I _{IOTM} , t=8/20us(qualification);

Reference application Specification

Symbol	Description	Min	Typ	Max	Unit
C _{VCC}	The filter capacitor of power supply is connected between vcc and gnd	0.1	0.47	/	uF
C _{V_{IOUT}}	The filter capacitor of Output is connected between Vout and gnd	1	1	1.5	nF
C _{VREF}	The filter capacitor of Output is connected between Vref and gnd	50	100	1000	pF
R _{Vfault}	The pull-up resistance is connected between Vfault and VCC	2	10	100	kΩ

Common Electrical Characteristics

Note: Over full range of $T_A=25^{\circ}\text{C}$, $C_{\text{Bypass}}=0.47\mu\text{F}$, $C_{\text{Load}}=1.0\text{nF}$, $V_{\text{CC}}=5\text{V}$, sensitivity=40mV/A

Characteristic	Symbol	Test Comditions	Nin	Typ	Max	Unit
Supply Voltage	V_{CC}	Operating	4.5	5	5.5	V
Supply Current	I_{CC}	$V_{\text{CC}} = 4.5\sim 5.5\text{V}$, output open		20		mA
Output Capacitance Load	C_{L}	VIOUT to GND	1.0	1.0	1.5	nF
Output Resistive Load	R_{L}	VIOUT to GND	3	10		k Ω
VREF Capacitance Load	C_{LREF}	VREF to GND	50	100	1000	pF
VREF Resistive Load	R_{LREF}	VREF to GND	3	10		k Ω
Hall coupling factor	CF	$T_A = 25^{\circ}\text{C}$		0.84		G/A
Anti-external magnetic interference suppression ratio	CMFR	The external interference magnetic field perpendicular to the chip surface		-38		dB
Primary Conductor Resistance	R_{PRIMARY}	$T_A = 25^{\circ}\text{C}$		0.6	1	m Ω
Temperature Coefficient of Primary Conductor Resistance	TCR	$T_A = -40\sim 125^{\circ}\text{C}$		3820		ppm/ $^{\circ}\text{C}$
Hysteresis Voltage	V_{hys}	V_{iout} (IP to +40A then return to 0A)- V_{iout} (IP to -40A, then return to 0A)		1		mV
Rise time	t_{r}	IP=50A		1.4		μs
Propagation Delay	t_{pd}	IP=50A		1.4		μs
Response Time	t_{response}	IP=50A		2		μs
Bandwidth	F	Small-Signal-3 dB,		200		kHz
Noise Density	I_{ND}	$T_A = 25^{\circ}\text{C}$, $C_{\text{L}}=1\text{nF}$		1403.1		$\mu\text{A}(\text{rms})/\sqrt{\text{Hz}}$
Noise	I_{N}	NC		427		mA(rms)
	I_{N}	RC filter BW=10KHz		123		mA(rms)
	I_{N}	RC filter BW=1KHz		82		mA(rms)
Nonlinearity	E_{LIN}	-50A<IP<50A			1	%
Bidirectional Quiescent Output(suitable for product with suffix B5)	S_{coef}	$V_{\text{CC}}=4.5\sim 5.5\text{V}$, $S_{\text{coef}}=\text{Sens}(V_{\text{CC}})/\text{Sens}(5\text{V})$		$V_{\text{CC}}/5$		
Sensitivity under fixed zero voltage(suitable for product with suffix F5)		$V_{\text{CC}}=4.5\sim 5.5\text{V}$		$2000/I_{\text{PR}}$		mv/A
$V_{\text{out}}@0\text{A}$ under fixed zero voltage(suitable for product with suffix F5)		$V_{\text{CC}}=4.5\sim 5.5\text{V}$		2.5		V
VIOUT LinearRail to Rail Output Range	$V_{\text{rail-rail}}$	$R_{\text{L}}=4.7\text{k}\Omega$	10		90	%VCC
Power-On Time	t_{PO}	Output reaches steady state level, $T_j = 25^{\circ}\text{C}$		100	200	μs
PSRR of $V_{\text{OUT}}@0\text{A}$ (suitable for product with suffix F5)	PSRR _Q			-40		dB
PSRR of Sensitivity(suitable for product with suffix F5)	PSRR _S			-15		dB
FAULT Function	I_{OP}	Primary Current Continuously Increases From IP, Until VFault is low		± 135		%IP
	I_{RE}	Primary Current Continuously Decreases From IP, Until VFault is high		± 110		%IP
	$T_{\text{r_fault}}$	Response Time of VFault		2		μs
	T_{HOLD}	Hold Time of VFault		2		μs

SC820RFT-25B5 Individual Performance Characteristics

Note: Over full range of $T_A = -40 \sim 125^\circ\text{C}$, $C_{\text{Bypass}} = 0.47\mu\text{F}$, $C_{\text{Load}} = 1.0\text{nF}$, $V_{\text{CC}} = 5\text{V}$, unless otherwise specified.

Parameter	Symbol	Test Conditions	Min	Typ ^[1]	Max	Unit
NOMINAL PERFORMANCE						
Current-Sensing Range	I_{PR}		-25		25	A
Zero-Current Output Voltage	V_{OQ}	$I_{\text{P}} = 0\text{A}$, $T_A = 25^\circ\text{C}$	$0.497V_{\text{CC}}$	$0.5V_{\text{CC}}$	$0.503V_{\text{CC}}$	V
Sensitivity	Sens	$-25\text{A} < I_{\text{P}} < 25\text{A}$	$79.6 * S_{\text{coef}}$	$80 * S_{\text{coef}}$	$80.4 * S_{\text{coef}}$	mV/A
TOTAL OUTPUT ERROR COMPONENTS: $E_{\text{TOT}} = E_{\text{SENS}} + V_{\text{OE}} / (\text{Sens} \times I_{\text{P}})$						
Sensitivity Error	E_{SENS}	$I_{\text{P}} = \pm 25\text{A}$, $T_A = 25^\circ\text{C}$		± 1		%
		$I_{\text{P}} = \pm 25\text{A}$, $T_A = 25 \sim 125^\circ\text{C}$		± 2.5		%
		$I_{\text{P}} = \pm 25\text{A}$, $T_A = -40 \sim 25^\circ\text{C}$		± 3.0		%
Offset Voltage	V_{OE}	$I_{\text{P}} = 0\text{A}$, $T_A = 25^\circ\text{C}$		± 15		mV
		$I_{\text{P}} = 0\text{A}$, $T_A = 25 \sim 125^\circ\text{C}$		± 40		mV
		$I_{\text{P}} = 0\text{A}$, $T_A = -40 \sim 25^\circ\text{C}$		± 35		mV
Nonlinearity	E_{LIN}	Measured using full-scale and half-scale I_{P}			1	%
ACCURACY PERFORMANCE						
Total Output Error ^[2]	E_{TOT}	$I_{\text{P}} = \pm 25\text{A}$, $T_A = 25^\circ\text{C}$		± 1		%
		$I_{\text{P}} = \pm 25\text{A}$, $T_A = 25^\circ\text{C} \sim 125^\circ\text{C}$	-3		3	%
		$I_{\text{P}} = \pm 25\text{A}$, $T_A = -40^\circ\text{C} \sim 25^\circ\text{C}$	-3		3	%

[1] The typical value is +/-1 sigma, and 68.27% of products fall within this range; The maximum/minimum value is +/-3 sigma value, and 99.73% of products fall within this range

[2] Percentage of I_{P} , with $I_{\text{P}} = I_{\text{PR(max)}}$.

SC820RFT-50B5 Individual Performance Characteristics

Note: Over full range of $T_A = -40 \sim 125^\circ\text{C}$, $C_{\text{Bypass}} = 0.47\mu\text{F}$, $C_{\text{Load}} = 1.0\text{nF}$, $V_{\text{CC}} = 5\text{V}$, unless otherwise specified.

Parameter	Symbol	Test Conditions	Min	Typ ^[1]	Max	Unit
NOMINAL PERFORMANCE						
Current-Sensing Range	I_{PR}		-50		50	A
Zero-Current Output Voltage	V_{OQ}	$I_{\text{P}} = 0\text{A}$	$0.497V_{\text{CC}}$	$0.5V_{\text{CC}}$	$0.503V_{\text{CC}}$	V
Sensitivity	Sens	$-50\text{A} < I_{\text{P}} < 50\text{A}$	$39.8 * S_{\text{coef}}$	$40 * S_{\text{coef}}$	$40.2 * S_{\text{coef}}$	mV/A
TOTAL OUTPUT ERROR COMPONENTS: $E_{\text{TOT}} = E_{\text{SENS}} + V_{\text{OE}} / (\text{Sens} \times I_{\text{P}})$						
Sensitivity Error	E_{SENS}	$I_{\text{P}} = \pm 50\text{A}$, $T_A = 25^\circ\text{C}$		± 1		%
		$I_{\text{P}} = \pm 50\text{A}$, $T_A = 25 \sim 125^\circ\text{C}$		± 2.5		%
		$I_{\text{P}} = \pm 50\text{A}$, $T_A = -40 \sim 25^\circ\text{C}$		± 3.0		%
Offset Voltage	V_{OE}	$I_{\text{P}} = 0\text{A}$, $T_A = 25^\circ\text{C}$		± 15		mV
		$I_{\text{P}} = 0\text{A}$, $T_A = 25 \sim 125^\circ\text{C}$		± 30		mV
		$I_{\text{P}} = 0\text{A}$, $T_A = -40 \sim 25^\circ\text{C}$		± 25		mV
Nonlinearity	E_{LIN}	Measured using full-scale and half-scale I_{P}			1	%
ACCURACY PERFORMANCE						
Total Output Error ^[2]	E_{TOT}	$I_{\text{P}} = \pm 50\text{A}$, $T_A = 25^\circ\text{C}$		± 1		%
		$I_{\text{P}} = \pm 50\text{A}$, $T_A = 25^\circ\text{C} \sim 125^\circ\text{C}$	-3		3	%
		$I_{\text{P}} = \pm 50\text{A}$, $T_A = -40^\circ\text{C} \sim 25^\circ\text{C}$	-3		3	%

[1] The typical value is +/-1 sigma, and 68.27% of products fall within this range; The maximum/minimum value is +/-3 sigma value, and 99.73% of products fall within this range

[2] Percentage of I_{P} , with $I_{\text{P}} = I_{\text{PR(max)}}$.

SC820DFT-50F5 Individual Performance Characteristics

Note: Over full range of $T_A = -40 \sim 125^\circ\text{C}$, $C_{\text{Bypass}} = 0.47\mu\text{F}$, $C_{\text{Load}} = 1.0\text{nF}$, $V_{\text{CC}} = 5\text{V}$, unless otherwise specified.

Parameter	Symbol	Test Conditions	Min	Typ ^[1]	Max	Unit
NOMINAL PERFORMANCE						
Current-Sensing Range	I_{PR}		-50		50	A
Zero-Current Output Voltage	V_{Oq}	$I_{\text{P}} = 0\text{A}$	2.485	2.5	2.515	V
VREF Output Voltage	V_{ref}	Independent of the IP input current	2.475	2.5	2.525	V
Differential Output Offset Voltage	$V_{\text{Oq}} - V_{\text{REF}}$	$I_{\text{P}} = 0\text{A}$	-25	0	25	mV
Sensitivity	Sens	$-50\text{A} < I_{\text{P}} < 50\text{A}$	39.8	40	40.2	mV/A
TOTAL OUTPUT ERROR COMPONENTS: $E_{\text{TOT}} = E_{\text{SENS}} + V_{\text{OE}} / (\text{Sens} \times I_{\text{P}})$						
Sensitivity Error	E_{SENS}	$I_{\text{P}} = \pm 50\text{A}$, $T_A = 25^\circ\text{C}$		± 1		%
		$I_{\text{P}} = \pm 50\text{A}$, $T_A = 25 \sim 125^\circ\text{C}$		± 2.5		%
		$I_{\text{P}} = \pm 50\text{A}$, $T_A = -40 \sim 25^\circ\text{C}$		± 3.0		%
Offset Voltage	V_{OE}	$I_{\text{P}} = 0\text{A}$, $T_A = 25^\circ\text{C}$		± 15		mV
		$I_{\text{P}} = 0\text{A}$, $T_A = 25 \sim 125^\circ\text{C}$		± 30		mV
		$I_{\text{P}} = 0\text{A}$, $T_A = -40 \sim 25^\circ\text{C}$		± 25		mV
Differential Output Error	$E_{(V_{\text{Oq}} - V_{\text{REF}})}$	$I_{\text{P}} = 0\text{A}$, $T_A = 25^\circ\text{C}$		± 15		mV
		$I_{\text{P}} = 0\text{A}$, $T_A = 25 \sim 125^\circ\text{C}$		± 25		mV
		$I_{\text{P}} = 0\text{A}$, $T_A = -40 \sim 25^\circ\text{C}$		± 30		mV
Nonlinearity	E_{LIN}	Measured using full-scale and half-scale I_{P}			1	%
ACCURACY PERFORMANCE						
Total Output Error ^[2]	E_{TOT}	$I_{\text{P}} = \pm 50\text{A}$, $T_A = 25^\circ\text{C}$		± 1		%
		$I_{\text{P}} = \pm 50\text{A}$, $T_A = 25^\circ\text{C} \sim 125^\circ\text{C}$	-3		3	%
		$I_{\text{P}} = \pm 50\text{A}$, $T_A = -40^\circ\text{C} \sim 25^\circ\text{C}$	-3		3	%

[1] The typical value is +/-1 sigma, and 68.27% of products fall within this range; The maximum/minimum value is +/-3 sigma value, and 99.73% of products fall within this range

[2] Percentage of I_{P} , with $I_{\text{P}} = I_{\text{PR(max)}}$.

SC820NFT-65B5 Individual Performance Characteristics

Note: Over full range of $T_A = -40 \sim 125^\circ\text{C}$, $C_{\text{Bypass}} = 0.47\mu\text{F}$, $C_{\text{Load}} = 1.0\text{nF}$, $V_{\text{CC}} = 5\text{V}$, unless otherwise specified.

Parameter	Symbol	Test Conditions	Min	Typ ^[1]	Max	Unit
NOMINAL PERFORMANCE						
Current-Sensing Range	I_{PR}		-65		65	A
Zero-Current Output Voltage	V_{Oq}	$I_{\text{P}} = 0\text{A}$	$0.497V_{\text{CC}}$	$0.5V_{\text{CC}}$	$0.503V_{\text{CC}}$	V
VREF Output Voltage	V_{ref}	Independent of the IP input current	$0.497V_{\text{CC}}$	$0.5V_{\text{CC}}$	$0.503V_{\text{CC}}$	V
Differential Output Offset Voltage	$V_{\text{Oq}} - V_{\text{REF}}$	$I_{\text{P}} = 0\text{A}$	-25	0	25	mV
Sensitivity	Sens	$-65\text{A} < I_{\text{P}} < 65\text{A}$	30.59^* S_{coef}	30.75^* S_{coef}	30.91^* S_{coef}	mV/A
TOTAL OUTPUT ERROR COMPONENTS: $E_{\text{TOT}} = E_{\text{SENS}} + V_{\text{OE}} / (\text{Sens} \times I_{\text{P}})$						
Sensitivity Error	E_{SENS}	$I_{\text{P}} = \pm 65\text{A}$, $T_A = 25^\circ\text{C}$		± 1		%
		$I_{\text{P}} = \pm 65\text{A}$, $T_A = 25 \sim 125^\circ\text{C}$		± 2.5		%
		$I_{\text{P}} = \pm 65\text{A}$, $T_A = -40 \sim 25^\circ\text{C}$		± 3.0		%
Offset Voltage	V_{OE}	$I_{\text{P}} = 0\text{A}$, $T_A = 25^\circ\text{C}$		± 15		mV
		$I_{\text{P}} = 0\text{A}$, $T_A = 25 \sim 125^\circ\text{C}$		± 30		mV
		$I_{\text{P}} = 0\text{A}$, $T_A = -40 \sim 25^\circ\text{C}$		± 25		mV
Differential Output Error	$E_{(V_{\text{Oq}} - V_{\text{REF}})}$	$I_{\text{P}} = 0\text{A}$, $T_A = 25^\circ\text{C}$		± 15		mV
		$I_{\text{P}} = 0\text{A}$, $T_A = 25 \sim 125^\circ\text{C}$		± 25		mV
		$I_{\text{P}} = 0\text{A}$, $T_A = -40 \sim 25^\circ\text{C}$		± 30		mV
Nonlinearity	E_{LIN}	Measured using full-scale and half-scale I_{P}			1	%
ACCURACY PERFORMANCE						
Total Output Error ^[2]	E_{TOT}	$I_{\text{P}} = \pm 65\text{A}$, $T_A = 25^\circ\text{C}$		± 1		%
		$I_{\text{P}} = \pm 65\text{A}$, $T_A = 25^\circ\text{C} \sim 125^\circ\text{C}$	-3		3	%
		$I_{\text{P}} = \pm 65\text{A}$, $T_A = -40^\circ\text{C} \sim 25^\circ\text{C}$	-3		3	%

[1] The typical value is +/-1 sigma, and 68.27% of products fall within this range; The maximum/minimum value is +/-3 sigma value, and 99.73% of products fall within this range

[2] Percentage of I_{P} , with $I_{\text{P}} = I_{\text{PR(max)}}$.

SC820DFT-20F5 Individual Performance Characteristics

Note: Over full range of $T_A = -40 \sim 125^\circ\text{C}$, $C_{\text{Bypass}} = 0.47\mu\text{F}$, $C_{\text{Load}} = 1.0\text{nF}$, $V_{\text{CC}} = 5\text{V}$, unless otherwise specified.

Parameter	Symbol	Test Conditions	Min	Typ ^[1]	Max	Unit
NOMINAL PERFORMANCE						
Current-Sensing Range	I_{PR}		-20		20	A
Zero-Current Output Voltage	V_{Oq}	$I_{\text{P}} = 0\text{A}$	2.485	2.5	2.515	V
VREF Output Voltage	V_{ref}	Independent of the IP input current	2.485	2.5	2.515	V
Differential Output Offset Voltage	$V_{\text{Oq}} - V_{\text{REF}}$	$I_{\text{P}} = 0\text{A}$	-15	0	15	mV
Sensitivity	Sens	$-20\text{A} < I_{\text{P}} < 20\text{A}$	99.5	100	100.5	mV/A
TOTAL OUTPUT ERROR COMPONENTS: $E_{\text{TOT}} = E_{\text{SENS}} + V_{\text{OE}} / (\text{Sens} \times I_{\text{P}})$						
Sensitivity Error	E_{SENS}	$I_{\text{P}} = \pm 20\text{A}$, $T_A = 25^\circ\text{C}$		± 1		%
		$I_{\text{P}} = \pm 20\text{A}$, $T_A = 25 \sim 125^\circ\text{C}$		± 2.5		%
		$I_{\text{P}} = \pm 20\text{A}$, $T_A = -40 \sim 25^\circ\text{C}$		± 3.0		%
Offset Voltage	V_{OE}	$I_{\text{P}} = 0\text{A}$, $T_A = 25^\circ\text{C}$		± 15		mV
		$I_{\text{P}} = 0\text{A}$, $T_A = 25 \sim 125^\circ\text{C}$		± 40		mV
		$I_{\text{P}} = 0\text{A}$, $T_A = -40 \sim 25^\circ\text{C}$		± 35		mV
Differential Output Error	$E_{(V_{\text{Oq}} - V_{\text{REF}})}$	$I_{\text{P}} = 0\text{A}$, $T_A = 25^\circ\text{C}$		± 15		mV
		$I_{\text{P}} = 0\text{A}$, $T_A = 25 \sim 125^\circ\text{C}$		± 35		mV
		$I_{\text{P}} = 0\text{A}$, $T_A = -40 \sim 25^\circ\text{C}$		± 30		mV
Nonlinearity	E_{LIN}	Measured using full-scale and half-scale I_{P}			1	%
ACCURACY PERFORMANCE						
Total Output Error ^[2]	E_{TOT}	$I_{\text{P}} = \pm 20\text{A}$, $T_A = 25^\circ\text{C}$		± 1		%
		$I_{\text{P}} = \pm 20\text{A}$, $T_A = 25^\circ\text{C} \sim 125^\circ\text{C}$	-3		3	%
		$I_{\text{P}} = \pm 20\text{A}$, $T_A = -40^\circ\text{C} \sim 25^\circ\text{C}$	-3		3	%

[1] The typical value is +/-1 sigma, and 68.27% of products fall within this range; The maximum/minimum value is +/-3 sigma value, and 99.73% of products fall within this range

[2] Percentage of I_{P} , with $I_{\text{P}} = I_{\text{PR(max)}}$.

SC820DFT-30F5 Individual Performance Characteristics

Note: Over full range of $T_A = -40 \sim 125^\circ\text{C}$, $C_{\text{Bypass}} = 0.47\mu\text{F}$, $C_{\text{Load}} = 1.0\text{nF}$, $V_{\text{CC}} = 5\text{V}$, unless otherwise specified.

Parameter	Symbol	Test Conditions	Min	Typ ^[1]	Max	Unit
NOMINAL PERFORMANCE						
Current-Sensing Range	I_{PR}		-30		30	A
Zero-Current Output Voltage	V_{Oq}	$I_{\text{P}} = 0\text{A}$	2.485	2.5	2.515	V
VREF Output Voltage	V_{ref}	Independent of the IP input current	2.485	2.5	2.515	V
Differential Output Offset Voltage	$V_{\text{Oq}} - V_{\text{REF}}$	$I_{\text{P}} = 0\text{A}$	-15	0	15	mV
Sensitivity	Sens	$-30\text{A} < I_{\text{P}} < 30\text{A}$	65.7	66	66.3	mV/A
TOTAL OUTPUT ERROR COMPONENTS: $E_{\text{TOT}} = E_{\text{SENS}} + V_{\text{OE}} / (\text{Sens} \times I_{\text{P}})$						
Sensitivity Error	E_{SENS}	$I_{\text{P}} = \pm 30\text{A}$, $T_A = 25^\circ\text{C}$		± 1		%
		$I_{\text{P}} = \pm 30\text{A}$, $T_A = 25 \sim 125^\circ\text{C}$		± 2.5		%
		$I_{\text{P}} = \pm 30\text{A}$, $T_A = -40 \sim 25^\circ\text{C}$		± 3.0		%
Offset Voltage	V_{OE}	$I_{\text{P}} = 0\text{A}$, $T_A = 25^\circ\text{C}$		± 15		mV
		$I_{\text{P}} = 0\text{A}$, $T_A = 25 \sim 125^\circ\text{C}$		± 30		mV
		$I_{\text{P}} = 0\text{A}$, $T_A = -40 \sim 25^\circ\text{C}$		± 25		mV
Differential Output Error	$E_{(V_{\text{Oq}} - V_{\text{REF}})}$	$I_{\text{P}} = 0\text{A}$, $T_A = 25^\circ\text{C}$		± 15		mV
		$I_{\text{P}} = 0\text{A}$, $T_A = 25 \sim 125^\circ\text{C}$		± 25		mV
		$I_{\text{P}} = 0\text{A}$, $T_A = -40 \sim 25^\circ\text{C}$		± 30		mV
Nonlinearity	E_{LIN}	Measured using full-scale and half-scale I_{P}			1	%
ACCURACY PERFORMANCE						
Total Output Error ^[2]	E_{TOT}	$I_{\text{P}} = \pm 30\text{A}$, $T_A = 25^\circ\text{C}$		± 1		%
		$I_{\text{P}} = \pm 30\text{A}$, $T_A = 25^\circ\text{C} \sim 125^\circ\text{C}$	-3		3	%
		$I_{\text{P}} = \pm 30\text{A}$, $T_A = -40^\circ\text{C} \sim 25^\circ\text{C}$	-3		3	%

[1] The typical value is +/-1 sigma, and 68.27% of products fall within this range; The maximum/minimum value is +/-3 sigma value, and 99.73% of products fall within this range

[2] Percentage of I_{P} , with $I_{\text{P}} = I_{\text{PR(max)}}$.

SC820DFT-50F5 Individual Performance Characteristics

Note: Over full range of $T_A = -40 \sim 125^\circ\text{C}$, $C_{\text{Bypass}} = 0.47\mu\text{F}$, $C_{\text{Load}} = 1.0\text{nF}$, $V_{\text{CC}} = 5\text{V}$, unless otherwise specified.

Parameter	Symbol	Test Conditions	Min	Typ ^[1]	Max	Unit
NOMINAL PERFORMANCE						
Current-Sensing Range	I_{PR}		-50		50	A
Zero-Current Output Voltage	V_{OQ}	$I_{\text{P}} = 0\text{A}$	2.485	2.5	2.515	V
VREF Output Voltage	V_{REF}	Independent of the IP input current	2.485	2.5	2.515	V
Differential Output Offset Voltage	$V_{\text{OQ}} - V_{\text{REF}}$	$I_{\text{P}} = 0\text{A}$	-15	0	15	mV
Sensitivity	S_{ENS}	$-50\text{A} < I_{\text{P}} < 50\text{A}$	39.8	40	40.2	mV/A
TOTAL OUTPUT ERROR COMPONENTS: $E_{\text{TOT}} = E_{\text{SENS}} + V_{\text{OE}} / (S_{\text{ENS}} \times I_{\text{P}})$						
Sensitivity Error	E_{SENS}	$I_{\text{P}} = \pm 50\text{A}$, $T_A = 25^\circ\text{C}$		± 1		%
		$I_{\text{P}} = \pm 50\text{A}$, $T_A = 25 \sim 125^\circ\text{C}$		± 2.5		%
		$I_{\text{P}} = \pm 50\text{A}$, $T_A = -40 \sim 25^\circ\text{C}$		± 3.0		%
Offset Voltage	V_{OE}	$I_{\text{P}} = 0\text{A}$, $T_A = 25^\circ\text{C}$		± 15		mV
		$I_{\text{P}} = 0\text{A}$, $T_A = 25 \sim 125^\circ\text{C}$		± 30		mV
		$I_{\text{P}} = 0\text{A}$, $T_A = -40 \sim 25^\circ\text{C}$		± 25		mV
Differential Output Error	$E_{(V_{\text{OQ}} - V_{\text{REF}})}$	$I_{\text{P}} = 0\text{A}$, $T_A = 25^\circ\text{C}$		± 15		mV
		$I_{\text{P}} = 0\text{A}$, $T_A = 25 \sim 125^\circ\text{C}$		± 25		mV
		$I_{\text{P}} = 0\text{A}$, $T_A = -40 \sim 25^\circ\text{C}$		± 30		mV
Nonlinearity	E_{LIN}	Measured using full-scale and half-scale I_{P}			1	%
ACCURACY PERFORMANCE						
Total Output Error ^[2]	E_{TOT}	$I_{\text{P}} = \pm 50\text{A}$, $T_A = 25^\circ\text{C}$		± 1		%
		$I_{\text{P}} = \pm 50\text{A}$, $T_A = 25^\circ\text{C} \sim 125^\circ\text{C}$	-3		3	%
		$I_{\text{P}} = \pm 50\text{A}$, $T_A = -40^\circ\text{C} \sim 25^\circ\text{C}$	-3		3	%

[1] The typical value is +/-1 sigma, and 68.27% of products fall within this range; The maximum/minimum value is +/-3 sigma value, and 99.73% of products fall within this range

[2] Percentage of I_{P} , with $I_{\text{P}} = I_{\text{PR(max)}}$.

SC820DFT-65F5 Individual Performance Characteristics

Note: Over full range of $T_A = -40 \sim 125^\circ\text{C}$, $C_{\text{Bypass}} = 0.47\mu\text{F}$, $C_{\text{Load}} = 1.0\text{nF}$, $V_{\text{CC}} = 5\text{V}$, unless otherwise specified.

Parameter	Symbol	Test Conditions	Min	Typ ^[1]	Max	Unit
NOMINAL PERFORMANCE						
Current-Sensing Range	I_{PR}		-65		65	A
Zero-Current Output Voltage	V_{OQ}	$I_{\text{P}} = 0\text{A}$	2.485	2.5	2.515	V
VREF Output Voltage	V_{REF}	Independent of the IP input current	2.485	2.5	2.515	V
Differential Output Offset Voltage	$V_{\text{OQ}} - V_{\text{REF}}$	$I_{\text{P}} = 0\text{A}$	-15	0	15	mV
Sensitivity	S_{ENS}	$-65\text{A} < I_{\text{P}} < 65\text{A}$	30.59	30.75	30.91	mV/A
TOTAL OUTPUT ERROR COMPONENTS: $E_{\text{TOT}} = E_{\text{SENS}} + V_{\text{OE}} / (S_{\text{ENS}} \times I_{\text{P}})$						
Sensitivity Error	E_{SENS}	$I_{\text{P}} = \pm 65\text{A}$, $T_A = 25^\circ\text{C}$		± 1		%
		$I_{\text{P}} = \pm 65\text{A}$, $T_A = 25 \sim 125^\circ\text{C}$		± 2.5		%
		$I_{\text{P}} = \pm 65\text{A}$, $T_A = -40 \sim 25^\circ\text{C}$		± 3.0		%
Offset Voltage	V_{OE}	$I_{\text{P}} = 0\text{A}$, $T_A = 25^\circ\text{C}$		± 15		mV
		$I_{\text{P}} = 0\text{A}$, $T_A = 25 \sim 125^\circ\text{C}$		± 30		mV
		$I_{\text{P}} = 0\text{A}$, $T_A = -40 \sim 25^\circ\text{C}$		± 25		mV
Differential Output Error	$E_{(V_{\text{OQ}} - V_{\text{REF}})}$	$I_{\text{P}} = 0\text{A}$, $T_A = 25^\circ\text{C}$		± 15		mV
		$I_{\text{P}} = 0\text{A}$, $T_A = 25 \sim 125^\circ\text{C}$		± 25		mV
		$I_{\text{P}} = 0\text{A}$, $T_A = -40 \sim 25^\circ\text{C}$		± 30		mV
Nonlinearity	E_{LIN}	Measured using full-scale and half-scale I_{P}			1	%
ACCURACY PERFORMANCE						
Total Output Error ^[2]	E_{TOT}	$I_{\text{P}} = \pm 65\text{A}$, $T_A = 25^\circ\text{C}$		± 1		%
		$I_{\text{P}} = \pm 65\text{A}$, $T_A = 25^\circ\text{C} \sim 125^\circ\text{C}$	-3		3	%
		$I_{\text{P}} = \pm 65\text{A}$, $T_A = -40^\circ\text{C} \sim 25^\circ\text{C}$	-3		3	%

[1] The typical value is +/-1 sigma, and 68.27% of products fall within this range; The maximum/minimum value is +/-3 sigma value, and 99.73% of products fall within this range

[2] Percentage of I_{P} , with $I_{\text{P}} = I_{\text{PR(max)}}$.

SC820DFT-20U5 Individual Performance Characteristics

Note: Over full range of $T_A = -40 \sim 125^\circ\text{C}$, $C_{\text{Bypass}} = 0.47\mu\text{F}$, $C_{\text{Load}} = 1.0\text{nF}$, $V_{\text{CC}} = 5\text{V}$, unless otherwise specified.

Parameter	Symbol	Test Conditions	Min	Typ ^[1]	Max	Unit
NOMINAL PERFORMANCE						
Current-Sensing Range	I_{PR}		0		20	A
Zero-Current Output Voltage	V_{OQ}	$I_{\text{P}} = 0\text{A}$		0.1VCC		V
VREF Output Voltage	V_{REF}	Independent of the IP input current	0.485	0.5	0.515	V
Differential Output Offset Voltage	$V_{\text{OQ}} - V_{\text{REF}}$	$I_{\text{P}} = 0\text{A}$	-15	0	15	mV
Sensitivity	Sens	$0\text{A} < I_{\text{P}} < 20\text{A}$	$199 * S_{\text{coef}}$	$200 * S_{\text{coef}}$	$201 * S_{\text{coef}}$	mV/A
TOTAL OUTPUT ERROR COMPONENTS: $E_{\text{TOT}} = E_{\text{SENS}} + V_{\text{OE}} / (\text{Sens} \times I_{\text{P}})$						
Sensitivity Error	E_{SENS}	$I_{\text{P}} = 20\text{A}$, $T_A = 25^\circ\text{C}$		± 1		%
		$I_{\text{P}} = 20\text{A}$, $T_A = 25 \sim 125^\circ\text{C}$		± 2.5		%
		$I_{\text{P}} = 20\text{A}$, $T_A = -40 \sim 25^\circ\text{C}$		± 3.0		%
Offset Voltage	V_{OE}	$I_{\text{P}} = 0\text{A}$, $T_A = 25^\circ\text{C}$		± 15		mV
		$I_{\text{P}} = 0\text{A}$, $T_A = 25 \sim 125^\circ\text{C}$		± 45		mV
		$I_{\text{P}} = 0\text{A}$, $T_A = -40 \sim 25^\circ\text{C}$		± 40		mV
Differential Output Error	$E_{(V_{\text{OQ}} - V_{\text{REF}})}$	$I_{\text{P}} = 0\text{A}$, $T_A = 25^\circ\text{C}$		± 15		mV
		$I_{\text{P}} = 0\text{A}$, $T_A = 25 \sim 125^\circ\text{C}$		± 45		mV
		$I_{\text{P}} = 0\text{A}$, $T_A = -40 \sim 25^\circ\text{C}$		± 40		mV
Nonlinearity	E_{LIN}	Measured using full-scale and half-scale I_{P}			1	%
ACCURACY PERFORMANCE						
Total Output Error ^[2]	E_{TOT}	$I_{\text{P}} = 20\text{A}$, $T_A = 25^\circ\text{C}$		± 1		%
		$I_{\text{P}} = 20\text{A}$, $T_A = 25^\circ\text{C} \sim 125^\circ\text{C}$	-3		3	%
		$I_{\text{P}} = 20\text{A}$, $T_A = -40^\circ\text{C} \sim 25^\circ\text{C}$	-3		3	%

[1] The typical value is +/-1 sigma, and 68.27% of products fall within this range; The maximum/minimum value is +/-3 sigma value, and 99.73% of products fall within this range

[2] Percentage of I_{P} , with $I_{\text{P}} = I_{\text{PR(max)}}$.

Accuracy Characteristic Curve (SC820DFT-20F5)



AC & Dynamic Characteristic Curve

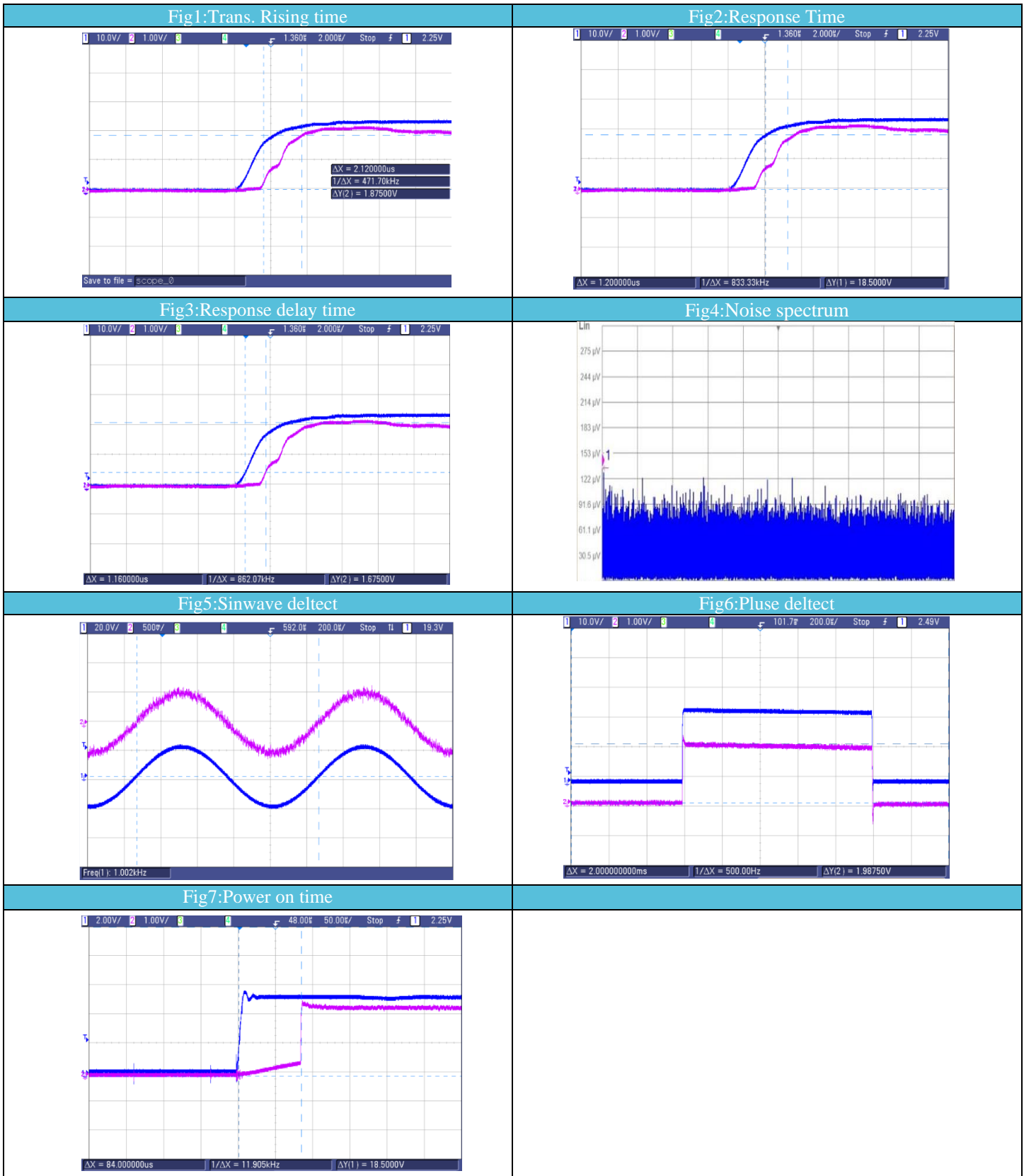

Functional Description

◆ Internal Reference Voltage

The device has an internal resistor divider from the analog supply VCC that determines the zero-current output voltage, VOUT@0A. This zero-current output level along with sensitivity determine the measurable input current range of the device, and allows for unidirectional or bidirectional sensing, as described in Absolute Maximum Ratings. The SC820xxT-xxB5 variants have a zero-current output set by Equation 1, while the SC820xxT-xxU5 devices have a zero-current output voltage set by Equation 2 and the SC820xxT-xxF5 have a zero-current output voltage set by Equation 3.

$$V_{OUT@0A} = V_{CC} \times 0.5 \quad (1)$$

$$V_{OUT@0A} = V_{CC} \times 0.1 \quad (2)$$

$$V_{OUT@0A} = 2.5V \quad (3)$$

◆ Vfault Function

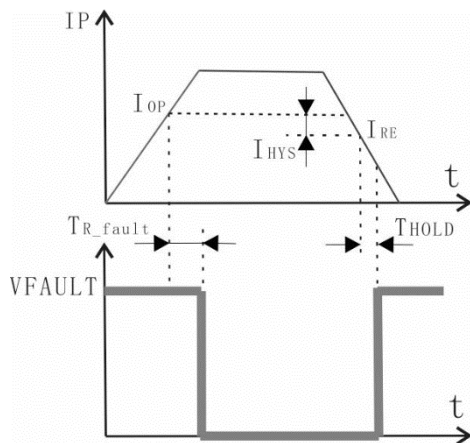

Vfault pin are used as an indicator output in over-current detection after pulling-up to VCC.

When primary current exceeds I_{OP} and after T_{R_fault} , Vfault pin will be low;

When primary current is below I_{RE} and after T_{HOLD} , Vfault pin will be high;

Parameter definition:

I_{OP} : Action threshold point, for SC820, $I_{OP} = IP \times 1.33$

I_{RE0} : Recover threshold point

I_{HYS} : Hysteresis, $I_{HYS} = |I_{OP}| - |I_{RE}|$

T_{R_fault} : The response time of Fault

T_{HOLD} : The hold time of Fault

◆ Proportional Coefficient Of Sensitivity(suitable for products with suffix B or U)

$$S_{coef} = Sens_coef = SENS_{VCC} / SENS_{VCCN}$$

It is the ratio of the sensitivity $SENS_{VCC}$ under the supply voltage Vcc to the sensitivity $SENS_{VCCN}$ under the rated supply voltage VCCN. Through this value, we can get the sensitivity under any supply voltage.

In ideal situation:

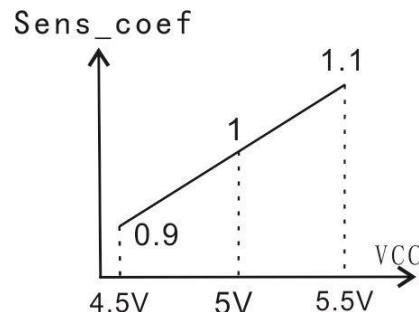

◆ Proportional Relationship

Zero-current voltage is fixed at 2.5V and sensitivity is fixed at $2V/IP_{MAX}$ when VCC change if using SC820xFT**F5. IP_{MAX} is the Maximum current.

Zero-current voltage is fixed at $VCC/2$ and sensitivity is fixed at $SENS_{VCC} \times Sens_coef$ when VCC change if using SC820xFT**B5.

Zero-current voltage is fixed at $VCC/10$ and sensitivity is fixed at $SENS_{VCC} \times Sens_coef$ when VCC change if using SC820xFT**U5.

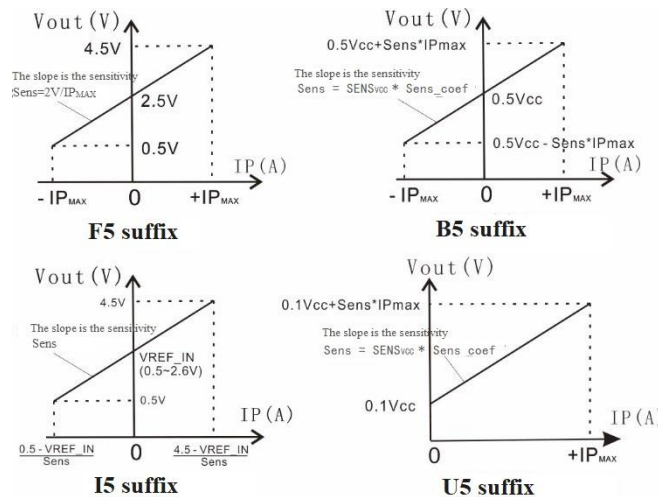

◆ Impact of External Magnetic Fields

CMFR is used to express the ability of sensor resisting impact of external magnetic fields. The larger the absolute value of CMFR, the stronger the ability to resist external magnetic interference is.

$$CMFR = 20 \lg \left| \frac{A_{CM}}{Sens/CF} \right|$$

CF is the coupling factor in G/A, multiplying by the sensitivity of the part (Sens) gives the error in mV.

For example: $CMFR = -40dB$, $Sens = 40mV/A$, $CF = 10G/A$, then A_{CM} is $0.04mV/G$.

◆ Power Supply Rejection Ratio (suitable for products with suffix F)

Sensitivity power supply rejection ratio (PSRR_S) It refers to the sensitivity change rate $(SENS_{VCC} - SENS_{VCCN})/SENS_{VCCN}$ caused by the power supply change rate $(VCC - VCCN)/VCCN$. The absolute value of the ratio is 20 times of the common logarithm, the unit is dB.

$$PSRR_S = 20 \lg \left| \frac{(VCC - VCCN)/VCCN}{(SENS_{VCC} - SENS_{VCCN})/SENS_{VCCN}} \right|$$

Zero current power supply rejection ratio (PSRR_Q) It refers to the zero point change $VOE - VOEN$ caused by the change of voltage $VCC - VCCN$. The absolute value of the ratio is 20 times of the common logarithm, the unit is dB

$$PSRR_Q = 20 \lg \left| \frac{VCC - VCCN}{VOE - VOEN} \right|$$

◆ **Delay time t_{pd} and Response time $t_{response}$**

Both delay time and response time are used to characterize the time difference between primary side and secondary side;

The delay time is the time difference when the secondary output reaches 20% of the steady-state output value and the primary output reaches 20% of the steady-state current;

The response time is the time difference when the secondary output reaches 90% of the steady-state output value and the primary output reaches 90% of the steady-state current.

Rise Time t_r

The time interval between a) when the sensor IC reaches 10% of its full-scale value, and b) when it reaches 90% of its full-scale value. The rise time to a step response is used to derive the bandwidth of the current sensor IC, in which $f(-3\text{ dB}) = 0.35/t_r$. Both t_r and $t_{RESPONSE}$ are detrimentally affected by eddy-current losses observed in the conductive IC ground plane.

Power-On Time t_{po}

Power-On Time is defined as the time it takes for the output voltage to settle within $\pm 10\%$ of its steady-state value under an applied magnetic field, after the power supply has reached its minimum specified operating voltage.

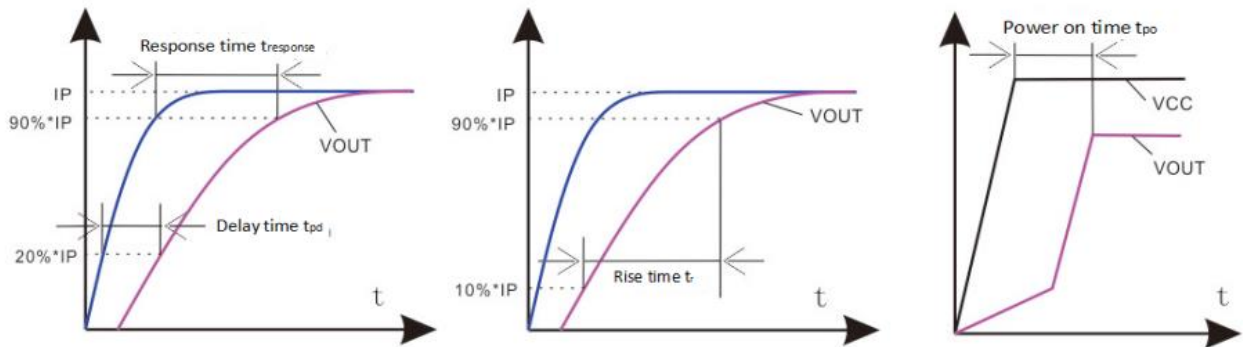

◆ **Thermal resistance $R_{\theta JA}$**

Based on a demo board, the thermal resistance is calculated by measuring the chip top temperature and power value. According to the thermal resistance, the junction temperature can be calculated as a reference. The actual surface temperature measurement value is shown in the relationship between the package temperature and the measured current.

$$T_J = T_A + (R_{\theta JA} * POWER) = T_A + (R_{\theta JA} * IP^2 * R_{PRIMARY});$$

Where T_J is junction temperature and T_A is ambient temperature.

◆ **Typical Application**

1. Typical application of Differential output:
 $V_{OUT} = IP * Sensitivity * (5R / R) * (V_{ref} - V_{iout})$

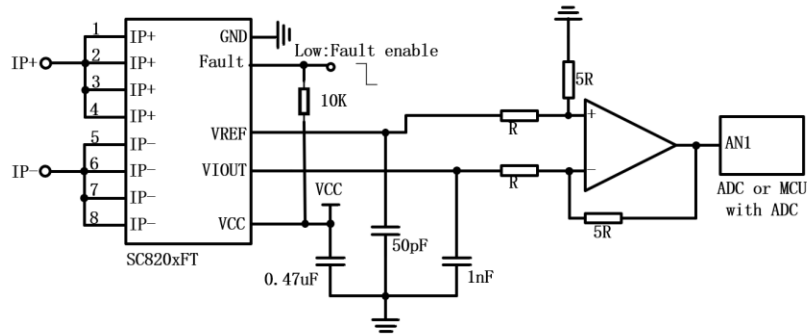

Fig1. Typical application diagram with Differential output

2. Typical application of single-ended output:
 $V_{OUT} = IP * Sensitivity + V_{ref}$

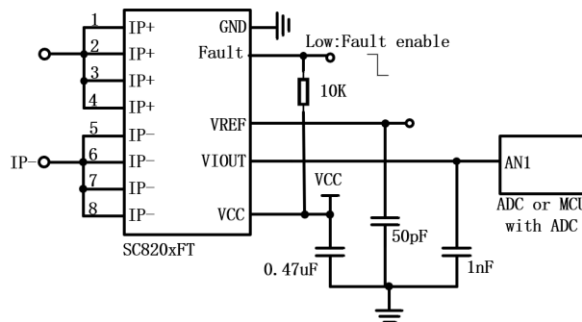

Fig2. Typical application diagram with single-ended output

3. Typical application of input synchronization mode:
 $V_{OUT} = IP * Sensitivity + V_{ref_in}$

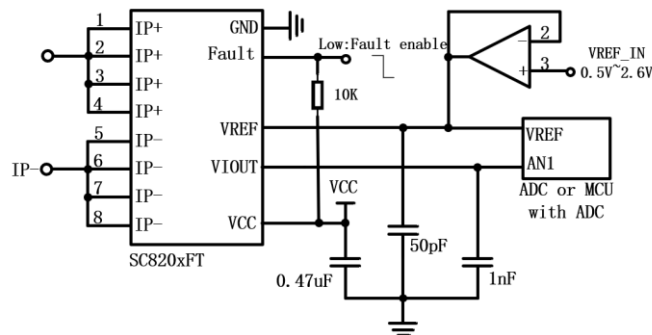
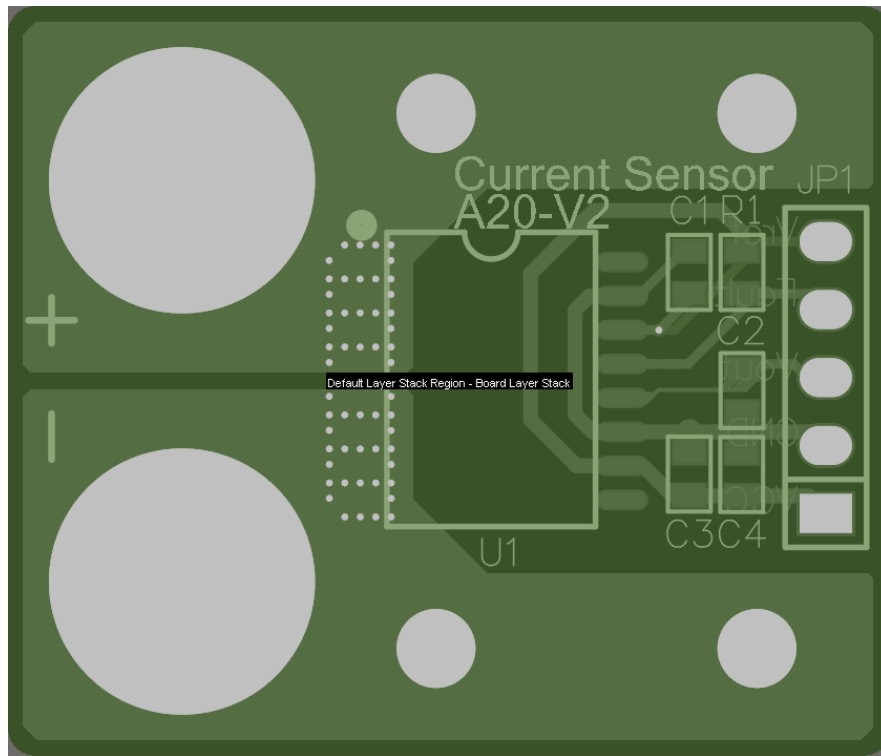
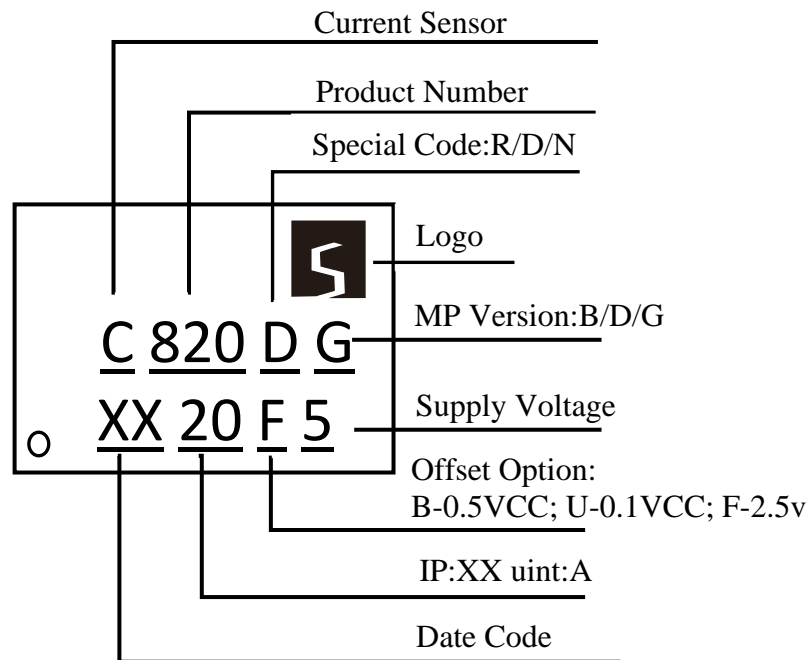

Fig3. Typical application diagram with input synchronization mode

SC820 Evaluation Board Layout



Mark Description



Package Information

Note: Package is SOP-16, all dimensions are in millimeters.

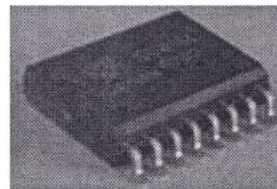
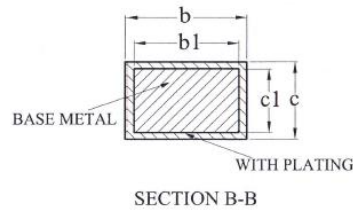
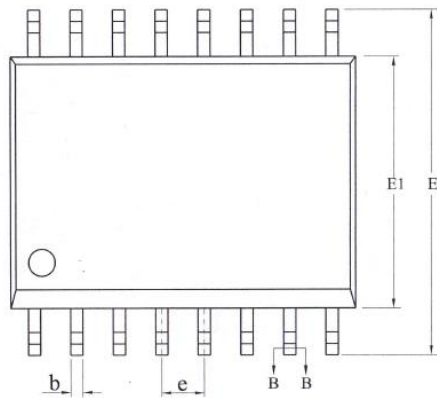
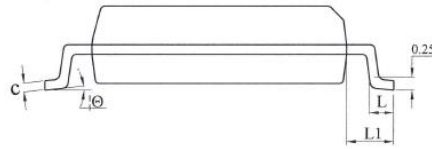
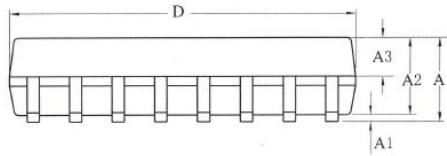

SYMBOL	MILLIMETER		
	MIN	NOM	MAX
A	—	—	2.65
A1	0.10	—	0.30
A2	2.25	2.30	2.35
A3	0.97	1.02	1.07
b	0.35	—	0.44
b1	0.34	0.37	0.39
c	0.25	—	0.31
c1	0.24	0.25	0.26
D	10.10	10.30	10.50
E	10.26	10.41	10.60
E1	7.30	7.50	7.70
e	1.27BSC		
L	0.55	—	0.85
L1	1.40BSC		
ø	0	—	8'

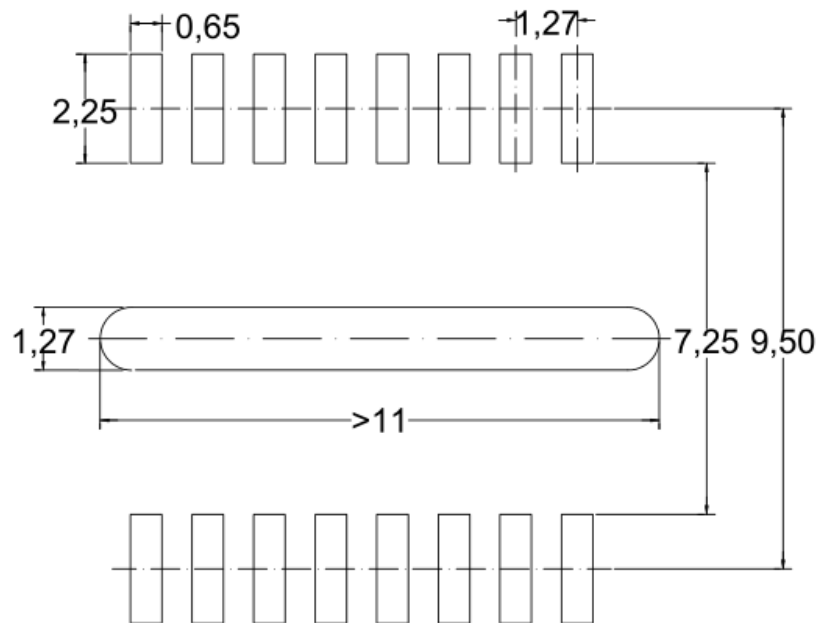

开槽可以保证爬电距离大于8mm

creepage distance > 8mm

PCB Layout Reference View

Important Notice

SENKO micro-electronics co., Ltd. Reserves the right to make, from time to time, such departures from the detail specifications as may be required to permit improvements in the performance, reliability, or manufacturability of its products. Before placing an order, the user is cautioned to verify that the information being relied upon is current.

SENKO micro’s products are not to be used in life support devices or systems, if a failure of an SENKO micro. product can reasonably be expected to cause the failure of that life support device or system, or to affect the safety or effectiveness of that device or system.

The information included herein is believed to be accurate and reliable. However, SENKO micro-electronics co., Ltd. assumes no responsibility for its use; nor for any infringement of patents or other rights of third parties which may result from its use.

For the latest version of this document, visit our website: www.senkomicro.com

Revision History

Revision	Change	Page	Author	Date
1.0	Initial draft		Jon	2014.03
1.1	Add unipolar IP detect mode		Jon	2016.07
1.2	Add Common mode field rejection		Jon	2017.04
1.3	Add figure, modify sensitivity		Hao	2017.12
1.4	Add SC820N		Hao	2018.01
1.5	Change Format		Hao	2018.03
1.6	Change Part Number in Order Information	2	Hao	2018.03
1.7	Modify Max Current Tolerance	3	Hao	2018.03
1.8	Remove Noise Spec, Charts		Hao	2018.04
1.9	Change Part Number	1	Hao	2018.06
2.0	Change Symbol define		Jon	2018.07
2.1	Change part name and selection guide		Jon	2018.08
2.2	Add reference schematic diagram	11	Kevin	2019.01
2.3	Add MP & sample information	2	Tom	2019.06
3.0	Change package info. And update e/c table		Jon	2019.06
3.1	Delete high sensitivity product, SC820NFT series change, revise Individual Performance Characteristics, add CHARACTERISTIC PERFORMANCE, add Thermal Rise vs. Primary Current	4,7,8,9	Tom	2019.07
3.2	Revise Primary Conductor Resistance according to test result.	1,5	Tom	2019.07
3.3	Add Nonlinearity & 25°C parameters	6	Tom	2019.07
3.4	Add SC820NFT-50F5 Individual data. Delete FAULT related information	5,8,10,11	Tom	2019.08
3.5	Revise pin assignment picture. Revise Thermal Rise vs. Primary Current	4,10	Tom	2019.09
3.6	ADD SC820RET-25B5, SC820RET-20B5	4	Tom	2019.10
3.7	DEL FAULT IN FEATURE	1	Tom	2019.11
3.8	Add Chinese information	1	Tom	2019.12
3.9	Add PCB LAYOUT reference view	12	Tom	2020.2
4.0	Add Application Information	11	Tom	2020.2
4.1	Update marking information and standardized typesetting		Jon	2020.03
4.2	Modify the information of some VREF and precision parameters	4	Jon	2020.03
4.3	Supplement version D to be compatible with the application	2	Jon	2020.03
4.4	Page2, supplement the R / D / N difference, Page7, supplement the parameters of NFT-50F5, - 65B5	2	Jon	2020.03
4.5	Page2, update R encapsulation definition	2	Jon	2020.03
4.6	Add 20U5	2	Jon	2020.04
4.7	Page2, change 4 model codes, and supplement vfault function parameters	2, 4	Jon	2020.05
4.8	Add SC820RFT-40F5	2	Jon	2020.07
4.9	Modify differential application formula	15	Jerry	2021.02
5.0	Modify the isolation withstand voltage parameters and update the block diagram	1, 3	Jerry	2021.03
5.1	Accuracy parameter correction		Jerry	2021.03
5.2	Add UL and environmental protection signs	1	Emma	2021.05
5.3	Add 50F5 performance index parameters	9	Jerry	2021.05

单击下面可查看定价，库存，交付和生命周期等信息

[>>Senko Micro\(兴工微\)](#)