

Isolated Current Sensor with Common Mode Field Rejection

Description

The SenkoMicro SC810 provides economical and precise solutions for AC or DC current sensing in industrial, commercial, and communications systems. The device package allows for easy implementation by the customer.

The device consists of a precise, low-offset, linear Hall circuit with a copper conduction path located near the surface of the die. Applied current flowing through this copper conduction path generates a magnetic field which the Hall IC converts into a proportional voltage. A precise, proportional voltage is provided by the low-offset, chopper-stabilized Linear Hall IC, which is programmed for accuracy after packaging.

The terminals of the conductive path (from pin1 and 2 to pin 3 and 4) are electrically isolated from the signal leads (pins 5 through 8). This allows the SC810 to be used in applications requiring electrical isolation without the use of opto-isolators or other costly isolation techniques.

Package: 8-Lead SOP-SC

Top View:



Current Path:

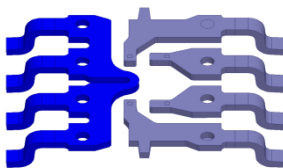

Features

- Differential hall sensing rejects common mode fields
- Output voltage proportional to AC or DC currents
- Selected Reference voltage mode: $V_{CC}/2$, $0.1 V_{CC}$
- Total output error 0.5% @ $T_A = 25^\circ C$, 3% for full temperature range.
- 4 μs output rise time in response to step input current
- 1.2m Ω internal conductor resistance
- > 2 kV RMS minimum isolation voltage from pins 1-4 to pins 5-8
- Nearly zero magnetic hysteresis
- Small footprint, low-profile SOP8-SC package

Application Field

- Smart power meter
- Brushless DC motor commutation
- Load detection and management
- Switch mode power supplies

Typical Application

- Support 0 ~ $\pm 30A$, AC or DC

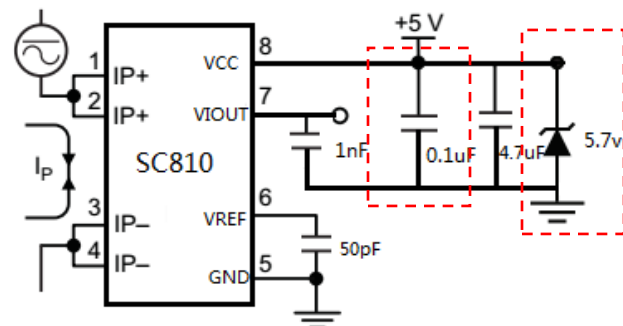

Note:

1. 4.7uF bypass is **MUST** have to guarantee performance;
2. 0.1uF bypass capacitor is optional for VCC;
3. The Zener or TVS diode is optional for protection purpose.

Order information

Part Number	Pin 6 Define	Temp Range	Packaging	IP(A)	Sens @ VCC=5V (mV/A)
SC810RFT-10B5	R (Default Vref)	F (-40~125°C)	T (Reel, 3000 Pieces/Reel)	+/-10	185
SC810RFT-20B5				+/-20	100
SC810RFT-30B5				+/-30	66
SC810RFT-10U5				10	264
SC810RFT-20U5				20	185
SC810RFT-30U5				30	133
SC810RFT-20F5				+/-20	100
SC810RFT-10F3				+/-10	135
SC810RFT-20F3				+/-20	67.5

*Any custom requirement, email to fae@senkomicro.com

Mark Description

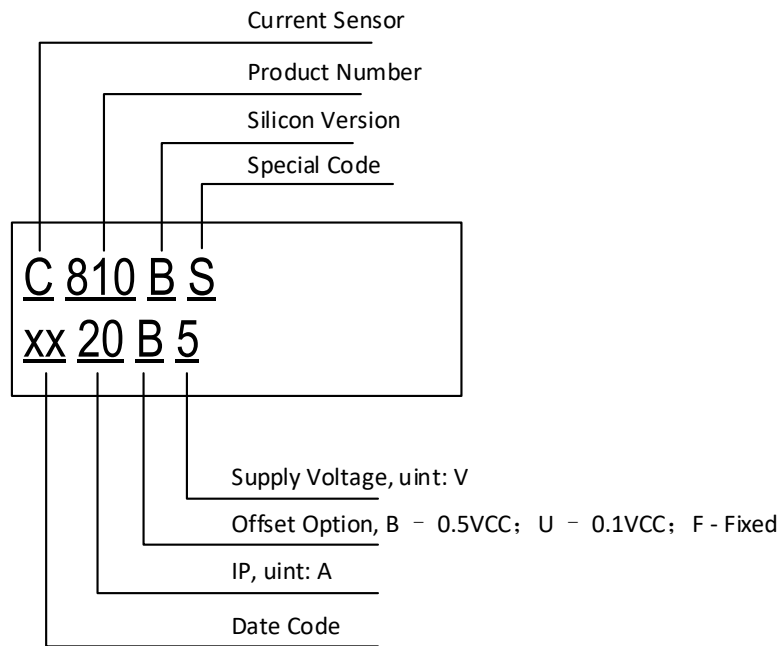

Functional Block Diagram

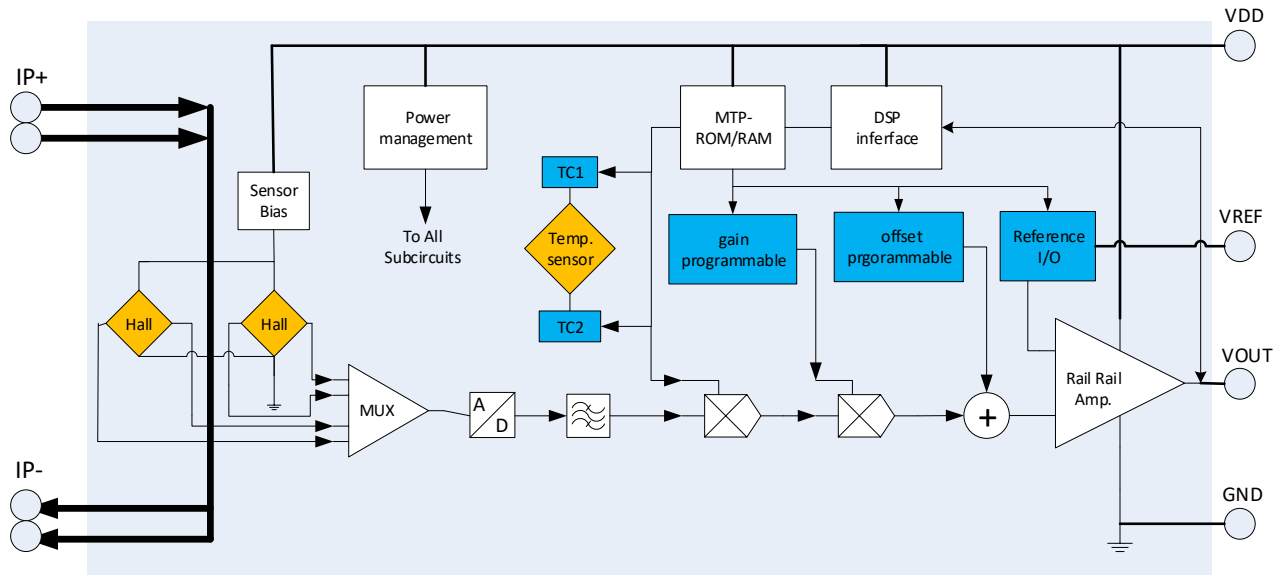

Pin Configuration

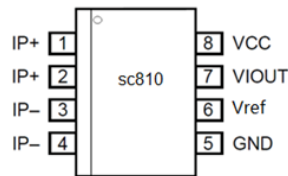

Number	Name	Description
1 and 2	IP+	Terminals for current being sampled; fused internally
3 and 4	IP-	Terminals for current being sampled; fused internally
5	GND	Signal Ground terminal
6	VREF	Reference voltage
7	VIOUT	Analog output signal
8	VCC	Device power supply terminal

Absolute Maximum Ratings

Absolute maximum ratings are limiting values to be applied individually, and beyond which the serviceability of the circuit may be impaired. Functional operability is not necessarily implied. Exposure to absolute maximum rating conditions for an extended period of time may affect device reliability.

Characteristic	Symbol	Notes	Rating	Unit
V _{CC}	Supply voltage		6.0	V
V _{RCC}	Reverse Supply Voltage		-0.1	V
V _{IOUT}	Output voltage		6.0	V
V _{RIOUT}	Reverse Output Voltage		-0.1	V
V _{ISO}	Dielectric Strength Test Voltage	Pins 1-4 and 5-8; 50 Hz, 1 minute, TA=25°C	2400	V _{RMS}
V _{WVBI}	Working Voltage for Basic Isolation	Maximum working voltage according to UL60950-1	420	V _{peak}
I _P	Overcurrent Transient Tolerance	1 pulse, 100ms, 1% duty cycle	50	A
I _{IOUT(SOURCE)}	Output Current Source		20	mA
I _{IOUT(SINK)}	Output Current Sink		20	mA
T _A	Nominal Operating Ambient Temperature	Range F	-40~125	°C
T _{J(max)}	Maximum Junction Temperature		165	°C
T _{stg}	Storage Temperature		-65~170	°C

Common operating Characteristics

Note: Over full range of T_A=-40°C ~ 125°C, C_{bypass}=4.7uF, C_{Load}=1.5nF, V_{CC}=5V, unless otherwise specified.

Parameter	Symbol	Test Condition	Min	Typ	Max	Units
Supply Voltage	V _{CC}	Operating	4.5	5	5.5	V
Supply Current	I _{CC}	V _{CC} = 5.0 V, output open		9	15	mA
Output Capacitance Load	C _{LOAD}	V _{IOUT} to GND		1.5	3	nF
Output Resistive Load	R _{LOAD}	V _{IOUT} to GND	0.17			kΩ
Primary Conductor Resistance	R _{PRIMARY}	T _A = 25°C		1.2	1.5	mΩ
Rise Time	t _r	I _P = I _{P(max)} , T _A = 25°C, C _{OUT} = open		4.0	5	μS
Frequency Bandwidth	f	-3 Db, T _A =25°C; I _P =10 A peak-to-peak		120		kHz
Nonlinearity	E _{LIN}	Over full range of I _P		0.3	1	%
Symmetry	E _{SYM}	Over full range of I _P	99	100	101	%
Power-On Time	T _{PO}	Output reaches 90% of steady-state level, T _J = 25°C, 20 A present			2	mS
Magnetic Coupling		T _{J(max)} is not exceeded		12		G/A
Internal Filter Resistance	R _{F(INT)}			1.7		KΩ
Power supply bypass capacitor	C _{bypass}	Normal operating	2.2	4.7		uF
Vref capacitance load	C _{REF}			0	100	pF

Common Thermal Characteristics

Parameter	Symbol	Test Condition	Min	Typ	Max	Units
Operating Internal Lead Frame Temperature	T _A	F range	-40		-125	°C
Junction-to-Lead Thermal Resistance	R _{θJL}				5	°C/W
Junction-to-Ambient Thermal Resistance	R _{θJA}				23	°C/W

X-10B Individual Performance Characteristics

Note: TJ(max) is not exceeded TA=-40°C ~ 125°C, C_{Bypass}=4.7uF, C_{Load}=1.5nF, VCC=5V, unless otherwise specified

Parameter	Symbol	Test Conditions	Min	Typ	Max	Units
Optimized Accuracy Range	I _P		-10		10	A
V _{IOUT @ 0A}	V _{OQ}	I _P =0A, T _A =25°C		0.5V _{CC}		V
Sensitivity	Sens	Over full of T _A =25°C		185		mV/A
Zero Current Output Slope	ΔI _{OUT(Q)}	T _A = -40~25°C		±0.34		mV/°C
		T _A = 25~125°C		±0.25		mV/°C
Sensitivity Slope	ΔSens	T _A = -40~25°C		0.023		mV/A/°C
		T _A = 25~125°C		-0.03		mV/A/°C
Total Output Error	E _{TOT}	I _P = ±10 A, T _A =25°C, output filtered		±0.5		%
		I _P = ±10 A, T _A =-40°C ~ 125°C, output filtered	-3		3	%

X-20B Individual Performance Characteristics

Note: TJ(max) is not exceeded TA=-40°C ~ 125°C, C_{Bypass}=4.7uf, C_{Load}=1.5nF, VCC=5V, unless otherwise specified

Parameter	Symbol	Test Conditions	Min	Typ	Max	Units
Optimized Accuracy Range	I _P		-20		20	A
V _{IOUT @ 0A}	V _{OQ}	I _P =0A, T _A =25°C		0.5V _{CC}		V
Sensitivity	Sens	Over full of T _A =25°C		100		mV/A
Zero Current Output Slope	ΔI _{OUT(Q)}	T _A = -40~25°C		-0.31		mV/°C
		T _A = 25~125°C		-0.2		mV/°C
Sensitivity Slope	ΔSens	T _A = -40~25°C		0.017		mV/A/°C
		T _A = 25~125°C		-0.01		mV/A/°C
Total Output Error	E _{TOT}	I _P = ±20 A, T _A =25°C, output filtered		±0.5		%
		I _P = ±20 A, T _A =-40°C ~ 125°C, output filtered	-3		3	%

X-30B Individual Performance Characteristics

Note: TJ(max) is not exceeded TA=-40°C ~ 125°C, C_{Bypass}=4.7uF, C_{Load}=1.5nF, VCC=5V, unless otherwise specified

Parameter	Symbol	Test Conditions	Min	Typ	Max	Units
Optimized Accuracy Range	I _P		-30		30	A
V _{IOUT @ 0A}	V _{OQ}	I _P =0A, T _A =25°C		0.5V _{CC}		V
Sensitivity	Sens	Over full of T _A =25°C		66		mV/A
Zero Current Output Slope	ΔI _{OUT(Q)}	T _A = -40~25°C		-0.3		mV/°C
		T _A = 25~125°C		-0.15		mV/°C
Sensitivity Slope	ΔSens	T _A = -40~25°C		0.017		mV/A/°C
		T _A = 25~125°C		-0.007		mV/A/°C
Total Output Error	E _{TOT}	I _P = ±30 A, T _A =25°C, output filtered		±0.5		%
		I _P = ±30 A, T _A =-40°C ~ 125°C, output filtered	-3		3	%

X-10U Individual Performance Characteristics

Note: $T_J(\max)$ is not exceeded $T_A = -40^\circ\text{C} \sim 125^\circ\text{C}$, $C_{\text{Bypass}} = 4.7\mu\text{F}$, $C_{\text{Load}} = 1.5\text{nF}$, $V_{\text{CC}} = 5\text{V}$, unless otherwise specified

Parameter	Symbol	Test Conditions	Min	Typ	Max	Units
Optimized Accuracy Range	I_P		0		10	A
V _{IOUT} @ 0A	V_{OQ}	$I_P = 0\text{A}$, $T_A = 25^\circ\text{C}$		0.1V _{CC}		V
Sensitivity	Sens	Over full of $T_A = 25^\circ\text{C}$		264		mV/A
Zero Current Output Slope	$\Delta I_{\text{OUT}(Q)}$	$T_A = -40 \sim 25^\circ\text{C}$		-0.4		mV/°C
		$T_A = 25 \sim 125^\circ\text{C}$		-0.3		mV/°C
Sensitivity Slope	ΔSens	$T_A = -40 \sim 25^\circ\text{C}$		0.03		mV/A/°C
		$T_A = 25 \sim 125^\circ\text{C}$		-0.04		mV/A/°C
Total Output Error	E_{TOT}	$I_P = 10\text{A}$, $T_A = 25^\circ\text{C}$, output filtered		± 0.5		%
		$I_P = 10\text{A}$, $T_A = -40^\circ\text{C} \sim 125^\circ\text{C}$, output filtered	-3		3	%

X-20U Individual Performance Characteristics

Note: $T_J(\max)$ is not exceeded $T_A = -40^\circ\text{C} \sim 125^\circ\text{C}$, $C_{\text{Bypass}} = 4.7\mu\text{F}$, $C_{\text{Load}} = 1.5\text{nF}$, $V_{\text{CC}} = 5\text{V}$, unless otherwise specified

Parameter	Symbol	Test Conditions	Min	Typ	Max	Units
Optimized Accuracy Range	I_P		0		20	A
V _{IOUT} @ 0A	V_{OQ}	$I_P = 0\text{A}$, $T_A = 25^\circ\text{C}$		0.1V _{CC}		V
Sensitivity	Sens	Over full of $T_A = 25^\circ\text{C}$		185		mV/A
Zero Current Output Slope	$\Delta I_{\text{OUT}(Q)}$	$T_A = -40 \sim 25^\circ\text{C}$		-0.34		mV/°C
		$T_A = 25 \sim 125^\circ\text{C}$		-0.25		mV/°C
Sensitivity Slope	ΔSens	$T_A = -40 \sim 25^\circ\text{C}$		0.023		mV/A/°C
		$T_A = 25 \sim 125^\circ\text{C}$		-0.03		mV/A/°C
Total Output Error	E_{TOT}	$I_P = 20\text{A}$, $T_A = 25^\circ\text{C}$, output filtered		± 0.5		%
		$I_P = 20\text{A}$, $T_A = -40^\circ\text{C} \sim 125^\circ\text{C}$, output filtered	-3		3	%

X-30U Individual Performance Characteristics

Note: $T_J(\max)$ is not exceeded $T_A = -40^\circ\text{C} \sim 125^\circ\text{C}$, $C_{\text{Bypass}} = 4.7\mu\text{F}$, $C_{\text{Load}} = 1.5\text{nF}$, $V_{\text{CC}} = 5\text{V}$, unless otherwise specified

Parameter	Symbol	Test Conditions	Min	Typ	Max	Units
Optimized Accuracy Range	I_P		0		30	A
V _{IOUT} @ 0A	V_{OQ}	$I_P = 0\text{A}$, $T_A = 25^\circ\text{C}$		0.1V _{CC}		V
Sensitivity	Sens	Over full of $T_A = 25^\circ\text{C}$		133		mV/A
Zero Current Output Slope	$\Delta I_{\text{OUT}(Q)}$	$T_A = -40 \sim 25^\circ\text{C}$		-0.31		mV/°C
		$T_A = 25 \sim 125^\circ\text{C}$		-0.2		mV/°C
Sensitivity Slope	ΔSens	$T_A = -40 \sim 25^\circ\text{C}$		0.017		mV/A/°C
		$T_A = 25 \sim 125^\circ\text{C}$		-0.01		mV/A/°C
Total Output Error	E_{TOT}	$I_P = 30\text{A}$, $T_A = 25^\circ\text{C}$, output filtered		± 0.5		%
		$I_P = 30\text{A}$, $T_A = -40^\circ\text{C} \sim 125^\circ\text{C}$, output filtered	-3		3	%

Typical Performance Graphs

Note: Over full range of $T_A = -40^{\circ}\text{C} \sim 125^{\circ}\text{C}$, $C_{\text{Bypass}} = 4.7\mu\text{f}$, $C_{\text{Load}} = 1.5\text{nF}$, $V_{\text{CC}} = 5\text{V}$, $I_P = 20\text{A}$, unless otherwise specified.

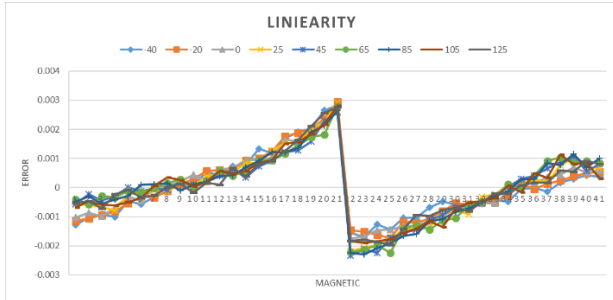

Figure 1. Linearity versus Ambient Temperature

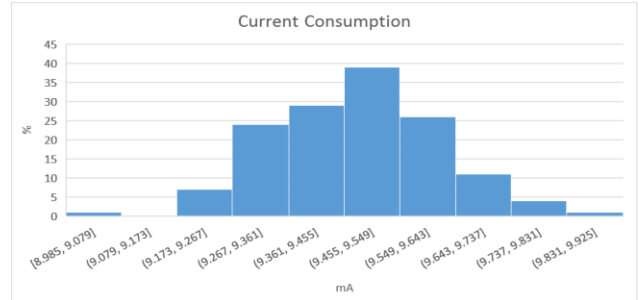

Figure 2. Current Consumption

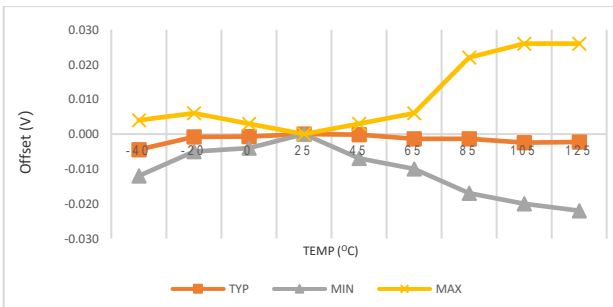

Figure 3. Zero Current Output versus Ambient Temperature

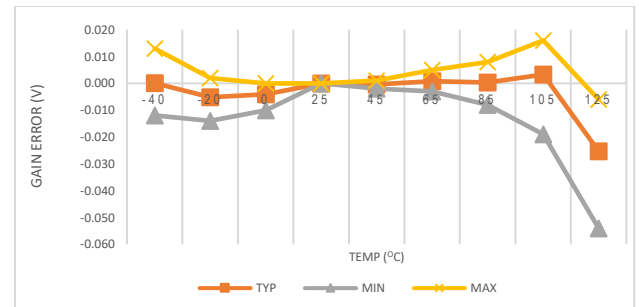

Figure 4. Sensitivity Error versus Ambient Temperature

Dynamic Performance

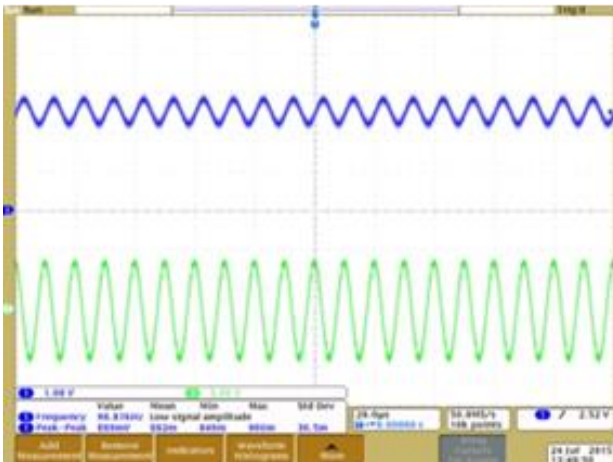

Figure 5. 100k 25A IP Frequency Response.

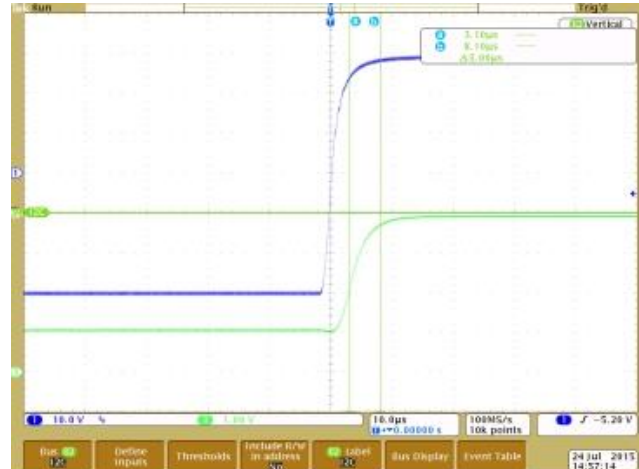
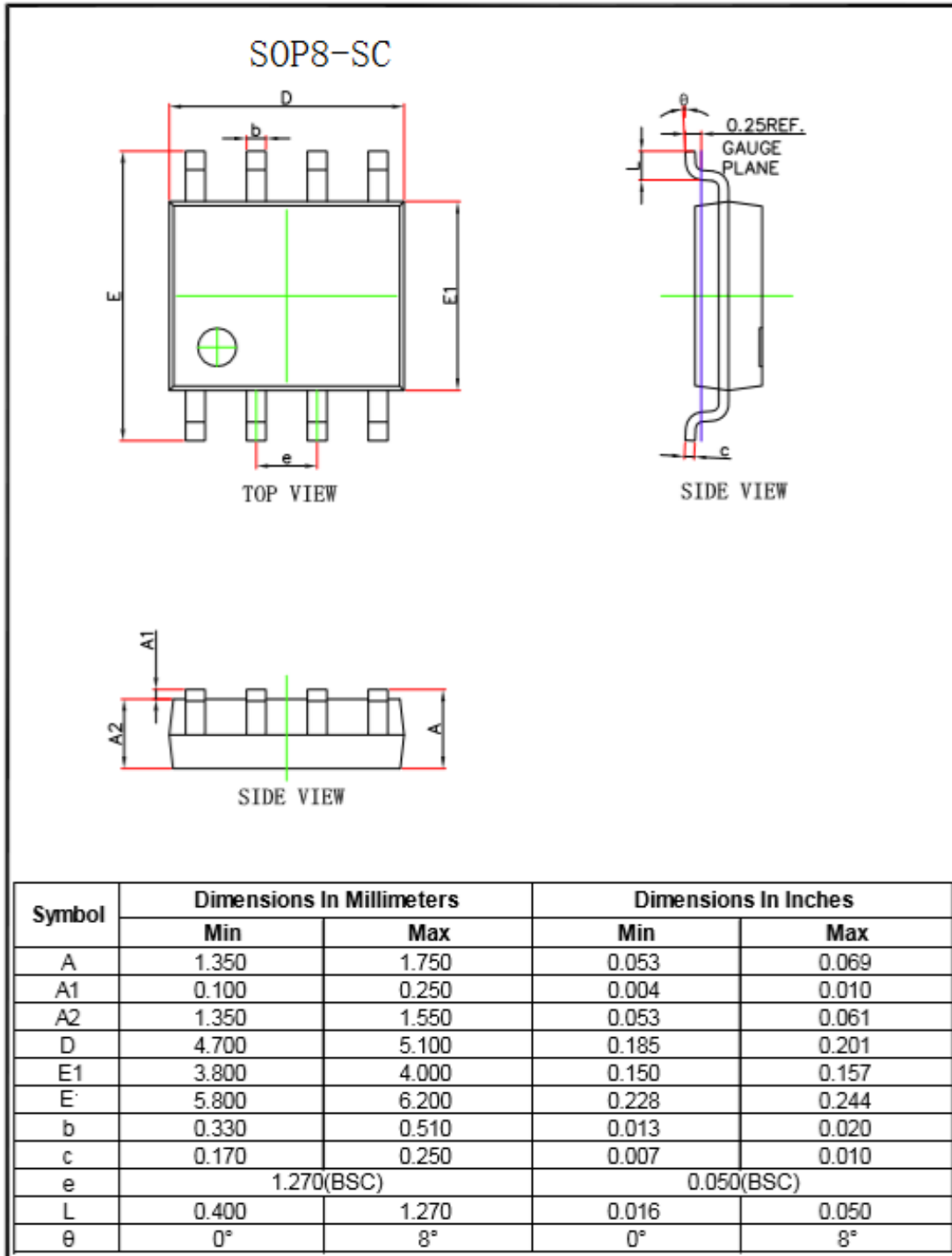

Figure 6. < 5uS Response Time

Package Information

Note: Package is SOP8-SC, all dimensions are in millimeters.



Important Notice

SENKO micro-electronics co., Ltd. reserves the right to make, from time to time, such departures from the detail specifications as may be required to permit improvements in the performance, reliability, or manufacturability of its products. Before placing an order, the user is cautioned to verify that the information being relied upon is current.

SENKO micro's products are not to be used in life support devices or systems, if a failure of an SENKO product can reasonably be expected to cause the failure of that life support device or system, or to affect the safety or effectiveness of that device or system.

The information included herein is believed to be accurate and reliable. However, SENKO micro-electronics co., Ltd. assumes no responsibility for its use; nor for any infringement of patents or other rights of third parties which may result from its use.

For the latest version of this document, visit our website: www.senkomicro.com

Revision Table

Revision	Change	Page	Author	Date
1.0	Initial draft		Jon	2014.03
1.1	Add unipolar IP detect mode		Jon	2016.07
1.2	Add Common mode field rejection		Jon	2017.04
1.7	Remove Vfault function		Hao	2017.12
1.8	Mark description		Hao	2018.01
1.9	Change format		Hao	2018.03
2.0	Modify Temp Range Code in Order Information	2	Hao	2018.03
2.1	Modify Package Name, Mark Description, Pin Config	1, 2, 3	Hao	2018.03
2.2	Remove noise and total error at all temp range		Hao	2018.04
2.3	Change Part Number	1	Hao	2018.06

单击下面可查看定价，库存，交付和生命周期等信息

[>>Senko Micro\(兴工微\)](#)