

SENSYLINK Microelectronics

(CTF2304)

1-CH Local + 8-CH Remote

***Temperature/Voltage Monitor and
4-CH Fan Speed Monitor and Driver***

CTF2304 is a system level thermal management solution chip, including 1-channel local temperature + 8-channels remote temperature/voltage monitor + 4-channels fan speed monitor and driver with I²C/SMBus digital interface.

It is ideally used in notebook, servers and telecom equipment system etc.

1. Description

The CTF2304 is a system level thermal management solution chip: 1-channel local temperature, 8-channels remote temperature or voltage monitor and 4-channels fan driver and speed controller. Temperature, voltage and fan speed data can be read out directly via SMBus/I²C bus interface.

The CTF2304 has 8 remote channels for monitoring the temperatures of external diode-connected transistors. Each channel of these 8 remote channels can be configured as voltage sensing for single-ended or differential inputs.

The CTF2304 has 3 fan control modes: 1) directly control duty cycle (Direct-DCY) mode, 2) automatically control according to the target fan speed value of rotation per minute (Auto-RPM) mode and 3) automatically control according to the temperature measured (Auto-Temp) mode. Each mode controls the fan speed by changing the duty cycle of a PWM output. In Direct-DCY mode, the PWM duty is set directly by the value written to the device. In Auto-RPM mode, the CTF2304 adjusts the PWM output to maintain a consistent fan speed at a user-specified target value. Auto-Temp allows the CTF2304 run as a stand-alone device without CPU intervention; the fan can continue to be controlled (based on temperature measurements) even if the CPU or system locks up. Each fan controller channel has its TACH reading to monitor the fan speed and detect fan failures.

The CTF2304 has a programmable $\overline{\text{ALERT}}$ output to indicate error conditions and a dedicated $\overline{\text{FANFAIL}}$

output to indicate fan failure. The $\overline{\text{THERM}}$ pin is a fail-safe output for over-temperature conditions that can be used to throttle a CPU clock.
Available Package: QFN3x3-24.

2. Features

- Operation voltage: 1.8V to 5.5V
- Digital interface compatible with SMBus and I²C
 - Support SMBus alert response address (ARA)
 - Packet error checking (PEC) is supported
 - Support block reading of measured data
- Multiple slave address options
 - Slave address is determined by the pull-up resistors of $\overline{\text{ALERT}}$ pin and $\overline{\text{THERM}}$ pin.
- Local temperature sensor
 - ±1°C accuracy, 0.0625°C resolution
- Remote temperature sensor
 - ±1°C accuracy, 0.0625°C resolution
- Temperature range: -40°C to +125°C
- PWM controller
 - PWM frequency: 10Hz to 40kHz
 - Duty cycle: 0% to 100%, 8 Bits
- Automatic fan speed control loops
- Programmable High/Low Limit $\overline{\text{ALERT}}$ and $\overline{\text{THERM}}$ temperature with hysteresis
- Intelligent $\overline{\text{FANFAIL}}$ detection

3. Applications

- Computer (Desktop & Notebook)
- Server
- Telecom equipment, Embedded applications

4. PIN Configurations (TOP View)

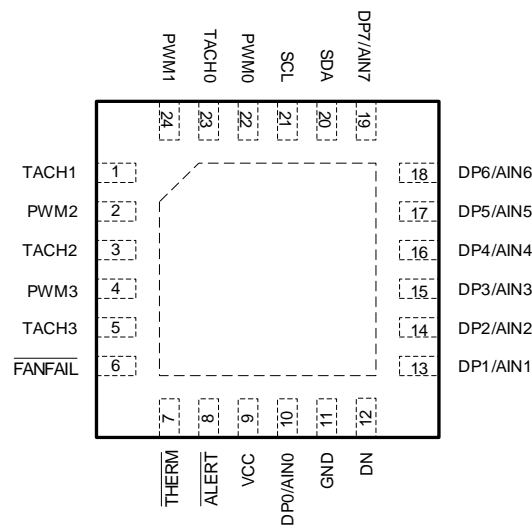

QFN3x3-24 (Package Code QN)

5. Typical Application

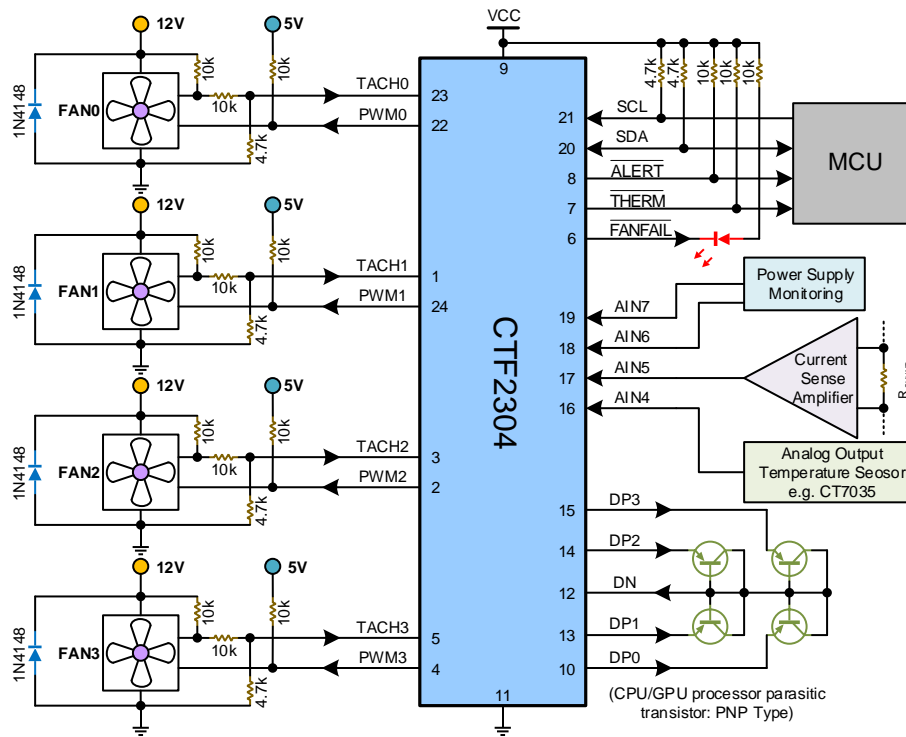

Figure 1 Typical Application of CTF2304

6. Pin Descriptions

PIN Name	PIN No.	Description
TACH1	1	Digital input, open drain. Fan tachometer input to measure the speed of Fan 1.
PWM2	2	Digital output, open drain. PWM output to control Fan 2 speed.
TACH2	3	Digital input, open drain. Fan tachometer input to measure the speed of Fan 2.
PWM3	4	Digital output, open drain. PWM output to control Fan 3 speed.
TACH3	5	Digital input, open drain. Fan tachometer input to measure the speed of Fan 3.
FANFAIL	6	Digital output, open drain. If the Fan Stall happens, this pin output low. If Fan Drive Fail happens, this pin output 50% PWM.
THERM	7	Digital input/output, open drain. As an output, an active low output indicates the temperature over the THERM temperature limit. As an input, the pin determines the SMBus device address according to its pull-up resistor.
ALERT	8	Digital input/output, open drain. As an output, if the measured temperature drops below the low-limit or rises above the high-limit, this pin will be activated low. As an input, the pin determines the SMBus device address according to its pull-up resistor.
VCC	9	Power supply input pin, using 0.1uF low ESR ceramic capacitor to ground.
DP0/AIN0	10	Remote channel 0 (RCH0). DP0 is used to measure temperature ⁽¹⁾ , it could be positive node of diodes, or BJT transistor (diode-connected mode). AIN0 is used to measure voltage, it could be analog input pin.
GND	11	Ground pin.
DN	12	Remote CH0 to CH7 negative input pin, it could be negative node of diodes, or BJT transistor (diode-connected mode).

(Continued)

PIN Name	PIN No.	Description
DP1/AIN1	13	Remote channel 1 (RCH1). DP1 is used to measure temperature ⁽¹⁾ , it could be positive node of diodes, or BJT transistor (diode-connected mode). AIN1 is used to measure voltage, it could be analog input pin.
DP2/AIN2	14	Remote channel 2 (RCH2). DP2 is used to measure temperature ⁽¹⁾ , it could be positive node of diodes, or BJT transistor (diode-connected mode). AIN2 is used to measure voltage, it could be analog input pin.
DP3/AIN3	15	Remote channel 3 (RCH3). DP3 is used to measure temperature ⁽¹⁾ , it could be positive node of diodes, or BJT transistor (diode-connected mode). AIN3 is used to measure voltage, it could be analog input pin.
DP4/AIN4	16	Remote channel 4 (RCH4). DP4 is used to measure temperature ⁽¹⁾ , it could be positive node of diodes, or BJT transistor (diode-connected mode). AIN4 is used to measure voltage, it could be analog input pin.
DP5/AIN5	17	Remote channel 5 (RCH5). DP5 is used to measure temperature ⁽¹⁾ , it could be positive node of diodes, or BJT transistor (diode-connected mode). AIN5 is used to measure voltage, it could be analog input pin.
DP6/AIN6	18	Remote channel 6 (RCH6). DP6 is used to measure temperature ⁽¹⁾ , it could be positive node of diodes, or BJT transistor (diode-connected mode). AIN6 is used to measure voltage, it could be analog input pin.
DP7/AIN7	19	Remote channel 7 (RCH7). DP7 is used to measure temperature ⁽¹⁾ , it could be positive node of diodes, or BJT transistor (diode-connected mode). AIN7 is used to measure voltage, it could be analog input pin.
SDA	20	Digital interface data input or output pin, need a pull-up resistor in application.
SCL	21	Digital interface clock input pin, need a pull-up resistor in application.
PWM0	22	Digital output, open drain. PWM output to control Fan 0 speed.
TACH0	23	Digital input, open drain. Fan tachometer input to measure the speed of Fan 0.
PWM1	24	Digital output, open drain. PWM output to control Fan 1 speed.

Note:
⁽¹⁾ It is recommended to use bypass capacitor ($C_d = 100\text{pF}$) plus serial resistor ($R_s = 50\text{ ohm}$) to remove noise between DPx and DN pin.

7. Function Block Diagram

Figure 2 CTF2304 Function Block Diagram

System Level Thermal Management Chip with Digital Interface
8. Ordering Information

Order PN	Accuracy	Green ¹	Package	Marking ID ²	Packing	MPQ	Operation Temperature
CTF2304QNR	±1°C	Halogen free	QFN3x3-24	2304 YWWAXX	Tape & Reel	3,000	-40°C ~ +125°C

Note:

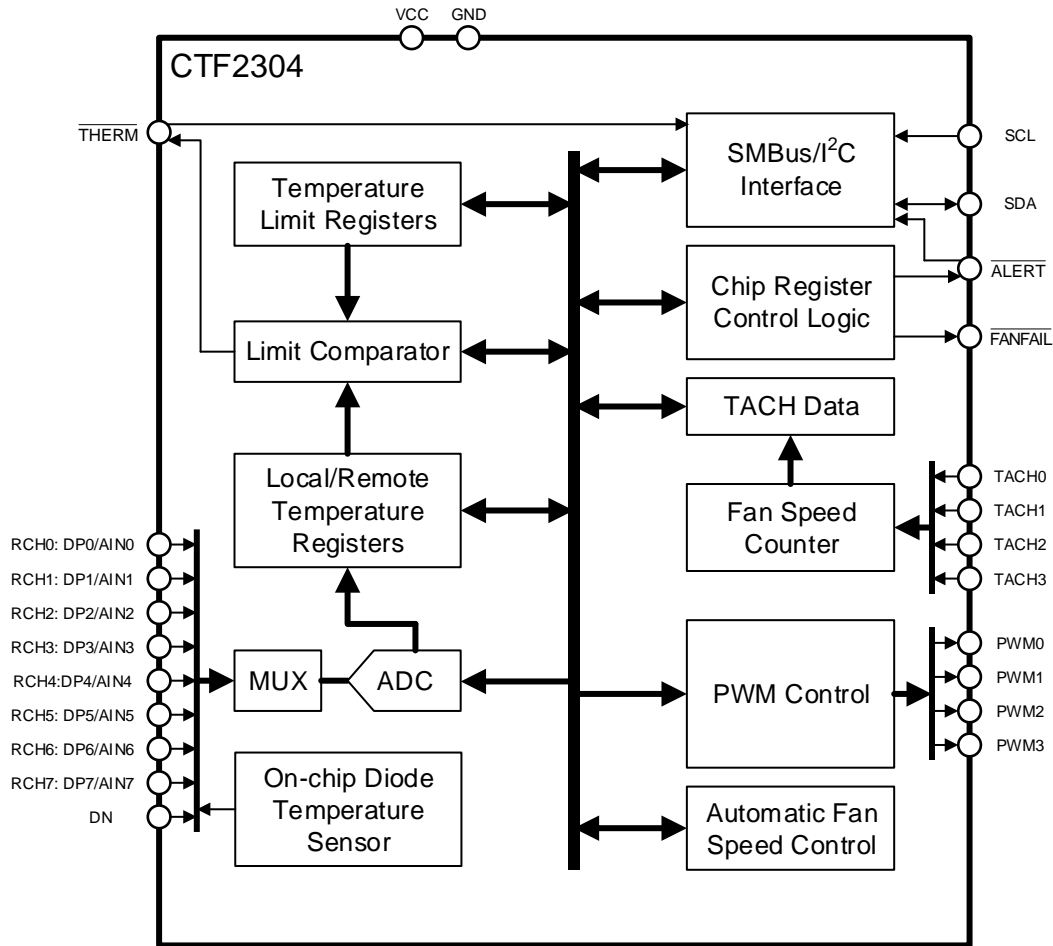
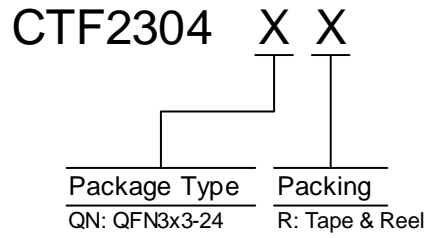
1. Based on ROHS Y2012 spec, Halogen free covers lead free. So most package types Sensylink offers only states halogen free, instead of lead free.
2. Marking ID includes 2 rows of characters. In general, the 1st row of characters are part number, and the 2nd row of characters are date code plus production information.



SENSYLINK Microelectronics Inc.

www.sensylink.com

IMPORTANT NOTICE

SENSYLINK Microelectronics Inc. reserves the right to make modifications, enhancements, improvements, corrections or other changes without further notice to this document and any product described herein or to discontinue any product or service. Customers should obtain the latest relevant information before placing orders and should verify the latest and complete information. SENSYLINK Microelectronics does not assume any responsibility for use of any product, nor does SENSYLINK Microelectronics any liability arising out of the application or use of this document or any product or circuit described herein. SENSYLINK Microelectronics assumes no liability for applications assistance or the design of Customers' products. Customers are responsible for their products and applications using SENSYLINK Microelectronics components. SENSYLINK Microelectronics does not convey any license under its patent or trademark rights nor the other rights.

SENSYLINK Microelectronics Inc. © 2015 - 2023.

单击下面可查看定价，库存，交付和生命周期等信息

[>>SENSYLINK](#)