



SGM4157YC

SPDT 0.8Ω Analog Switch

GENERAL DESCRIPTION

The SGM4157YC is a SPDT (single-pole/double-throw), TTL/CMOS compatible analog switch. It operates from a 1.8V to 5.5V single power supply.

The SGM4157YC features ultra-low on-resistance, low voltage and fast switching times. The high performances make it very suitable for multiple applications, such as cellular phones, computer peripherals, etc. Low power consumption is also one of the important reasons that make it a good choice.

The SGM4157YC is available in a Green SC70-6 package. It operates over an ambient temperature range of -40°C to +85°C.

FEATURES

- **Single Supply Voltage Range: 1.8V to 5.5V**
- **Ultra Low On-Resistance: 0.8Ω (TYP)**
- **Fast Switching Times at $V_+ = 5V$:**
 - t_{ON} : 56ns
 - t_{OFF} : 32ns
- **-3dB Bandwidth: 90MHz**
- **High Off-Isolation: -45dB at 10MHz**
- **TTL/CMOS Compatible**
- **Break-Before-Make Switching**
- **Rail-to-Rail Input and Output Operation**
- **-40°C to +85°C Operating Temperature Range**
- **Available in a Green SC70-6 Package**

APPLICATIONS

MP3s
Cellular Phones
Computer Peripherals
Portable Equipment
Sample-and-Hold Circuits
Battery-Powered Systems

PACKAGE/ORDERING INFORMATION

MODEL	PACKAGE DESCRIPTION	SPECIFIED TEMPERATURE RANGE	ORDERING NUMBER	PACKAGE MARKING	PACKING OPTION
SGM4157YC	SC70-6	-40°C to +85°C	SGM4157YC6/TR	MIAXX	Tape and Reel, 3000

MARKING INFORMATION

NOTE: XX = Date Code.

YYY X X

Date Code - Week
Date Code - Year
Serial Number

Green (RoHS & HSF): SG Micro Corp defines "Green" to mean Pb-Free (RoHS compatible) and free of halogen substances. If you have additional comments or questions, please contact your SGMICRO representative directly.

ABSOLUTE MAXIMUM RATINGS

V₊, IN to GND..... -0.3V to 6V
 Analog, Digital Voltage Range ⁽¹⁾-0.3V to (V₊) + 0.3V
 Continuous Current NO, NC, or COM..... ±150mA
 Peak Current NO, NC, or COM..... ±250mA
 Junction Temperature.....+150°C
 Storage Temperature Range-65°C to +150°C
 Lead Temperature (Soldering, 10s).....+260°C
 ESD Susceptibility
 HBM..... 8000V
 MM..... 400V

NOTE:

1. Signals on NC, NO, or COM or IN exceeding V₊ will be clamped by internal diodes. Limit forward diode current to maximum current ratings.

RECOMMENDED OPERATING CONDITIONS

Operating Temperature Range-40°C to +85°C

OVERSTRESS CAUTION

Stresses beyond those listed in Absolute Maximum Ratings may cause permanent damage to the device. Exposure to absolute maximum rating conditions for extended periods may affect reliability. Functional operation of the device at any conditions beyond those indicated in the Recommended Operating Conditions section is not implied.

ESD SENSITIVITY CAUTION

This integrated circuit can be damaged by ESD if you don't pay attention to ESD protection. SGMICRO recommends that all integrated circuits be handled with appropriate precautions. Failure to observe proper handling and installation procedures can cause damage. ESD damage can range from subtle performance degradation to complete device failure. Precision integrated circuits may be more susceptible to damage because very small parametric changes could cause the device not to meet its published specifications.

DISCLAIMER

SG Micro Corp reserves the right to make any change in circuit design, or specifications without prior notice.

PIN CONFIGURATION

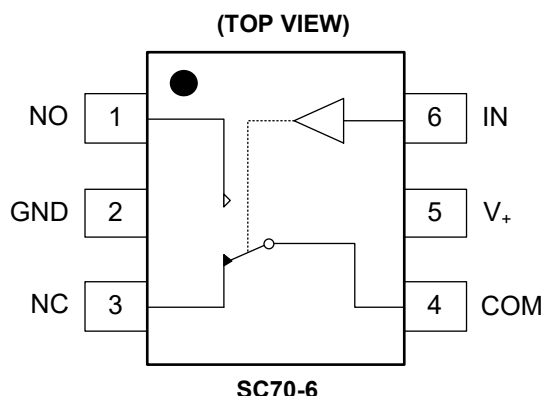

PIN DESCRIPTION

PIN	NAME	FUNCTION
1	NO	Normally Open Pin.
2	GND	Ground.
3	NC	Normally Closed Pin.
4	COM	Common Pin.
5	V+	Positive Power Supply Pin.
6	IN	Digital Control Input Pin to Connect the COM Pin to the NO or NC Pins.

NOTE: NO, NC and COM pins may be an input or output.

FUNCTION TABLE

LOGIC	NO	NC
0	OFF	ON
1	ON	OFF

NOTE: Switches shown for logic “0” input.

ELECTRICAL CHARACTERISTICS

(V₊ = 4.5V to 5.5V, GND = 0V, Full = -40°C to +85°C. Typical values are at T_A = +25°C, unless otherwise noted.)

PARAMETER	SYMBOL	CONDITIONS	TEMP	MIN	TYP	MAX	UNITS
ANALOG SWITCH							
Analog Signal Range	V _{NO} , V _{NC} , V _{COM}		+25°C	0		V ₊	V
On-Resistance	R _{ON}	V ₊ = 4.5V, 0V ≤ V _{NO} or V _{NC} ≤ V ₊ , I _{COM} = -100mA, Test Circuit 1	+25°C		0.8		Ω
On-Resistance Match Between Channels	ΔR _{ON}	V ₊ = 4.5V, 0V ≤ V _{NO} or V _{NC} ≤ V ₊ , I _{COM} = -100mA, Test Circuit 1	+25°C		0.02	0.2	Ω
			Full			0.3	
On-Resistance Flatness	R _{FLAT(ON)}	V ₊ = 4.5V, 0V ≤ V _{NO} or V _{NC} ≤ V ₊ , I _{COM} = -100mA, Test Circuit 1	+25°C		0.25	0.45	Ω
			Full			0.6	
Source Off Leakage Current	I _{NC(OFF)} , I _{NO(OFF)}	V ₊ = 5.5V, V _{NO} or V _{NC} = 4.5V/1V, V _{COM} = 1V/4.5V	+25°C		0.1		μA
			Full			1	
Channel On Leakage Current	I _{NC(ON)} , I _{NO(ON)} , I _{COM(ON)}	V ₊ = 5.5V, V _{COM} = 1V/4.5V, V _{NO} or V _{NC} = floating	+25°C		0.1		μA
			Full			1	
DIGITAL INPUTS							
Input High Voltage	V _{INH}	V ₊ = 4.5V	+25°C	1.6			V
Input Low Voltage	V _{INL}	V ₊ = 4.5V	+25°C			0.4	V
Input Leakage Current	I _{IN}	V ₊ = 4.5V, V _{IN} = 0V or V ₊	+25°C		0.1		μA
DYNAMIC CHARACTERISTICS							
Turn-On Time	t _{ON}	V ₊ = 4.5V, V _{NO} or V _{NC} = 3V, R _L = 300Ω, C _L = 35pF, Test Circuit 2	+25°C		56		ns
Turn-Off Time	t _{OFF}	V ₊ = 4.5V, V _{NO} or V _{NC} = 3V, R _L = 300Ω, C _L = 35pF, Test Circuit 2	+25°C		32		ns
Break-Before-Make Time Delay	t _D	V ₊ = 4.5V, V _{NO} or V _{NC} = 3V, R _L = 300Ω, C _L = 35pF, Test Circuit 3	+25°C		28		ns
Propagation Delay Time (Signal Input to Output)	t _{PD}	R _S = 39Ω, C _L = 50pF, Test Circuit 4	+25°C		7		ns
Off Isolation	O _{ISO}	V ₊ = 4.5V, R _L = 50Ω, Signal = 0dBm, Test Circuit 5	10MHz	+25°C	-45		dB
			1MHz	+25°C	-65		
-3dB Bandwidth	BW	V ₊ = 4.5V, Signal = 0dBm, R _L = 50Ω, Test Circuit 6	+25°C		90		MHz
Channel On Capacitance	C _{NC(ON)} , C _{NO(ON)} , C _{COM(ON)}	V ₊ = 4.5V, f = 1MHz	+25°C		40		pF
Channel Off Capacitance	C _{NC(OFF)} , C _{NO(OFF)} , C _{COM(OFF)}	V ₊ = 4.5V, f = 1MHz	+25°C		8.5		pF
POWER REQUIREMENTS							
Power Supply Range	V ₊		+25°C	1.8		5.5	V
Power Supply Current	I ₊	V ₊ = 5.5V, V _{IN} = 0V or V ₊	+25°C		0.1		μA

ELECTRICAL CHARACTERISTICS (continued)(V₊ = 2.7V to 3.6V, GND = 0V, Full = -40°C to +85°C. Typical values are at T_A = +25°C, unless otherwise noted.)

PARAMETER	SYMBOL	CONDITIONS	TEMP	MIN	TYP	MAX	UNITS
ANALOG SWITCH							
Analog Signal Range	V _{NO} , V _{NC} , V _{COM}		+25°C	0		V ₊	V
On-Resistance	R _{ON}	V ₊ = 2.7V, 0V ≤ V _{NO} or V _{NC} ≤ V ₊ , I _{COM} = -100mA, Test Circuit 1	+25°C		1.4		Ω
On-Resistance Match Between Channels	ΔR _{ON}	V ₊ = 2.7V, 0V ≤ V _{NO} or V _{NC} ≤ V ₊ , I _{COM} = -100mA, Test Circuit 1	+25°C		0.03	0.3	Ω
			Full			0.31	
On-Resistance Flatness	R _{FLAT(ON)}	V ₊ = 2.7V, 0V ≤ V _{NO} or V _{NC} ≤ V ₊ , I _{COM} = -100mA, Test Circuit 1	+25°C		0.9	1.2	Ω
			Full			1.25	
Source Off Leakage Current	I _{NC(OFF)} , I _{NO(OFF)}	V ₊ = 3.6V, V _{NO} or V _{NC} = 3.3V/0.3V, V _{COM} = 0.3V/3.3V	+25°C		0.1		μA
			Full			1	
Channel On Leakage Current	I _{NC(ON)} , I _{NO(ON)} , I _{COM(ON)}	V ₊ = 3.6V, V _{COM} = 0.3V/3.3V, V _{NO} or V _{NC} = floating	+25°C		0.1		μA
			Full			1	
DIGITAL INPUTS							
Input High Voltage	V _{INH}	V ₊ = 2.7V	+25°C	1.4			V
Input Low Voltage	V _{INL}	V ₊ = 2.7V	+25°C			0.4	V
Input Leakage Current	I _{IN}	V ₊ = 2.7V, V _{IN} = 0V or V ₊	+25°C		0.1		μA
DYNAMIC CHARACTERISTICS							
Turn-On Time	t _{ON}	V ₊ = 3V, V _{NO} or V _{NC} = 1.5V, R _L = 300Ω, C _L = 35pF, Test Circuit 2	+25°C		88		ns
Turn-Off Time	t _{OFF}	V ₊ = 3V, V _{NO} or V _{NC} = 1.5V, R _L = 300Ω, C _L = 35pF, Test Circuit 2	+25°C		46		ns
Break-Before-Make Time Delay	t _D	V ₊ = 3V, V _{NO} or V _{NC} = 1.5V, R _L = 300Ω, C _L = 35pF, Test Circuit 3	+25°C		43		ns
Propagation Delay Time (Signal Input to Output)	t _{PD}	R _S = 39Ω, C _L = 50pF, Test Circuit 4	+25°C		7		ns
Off Isolation	O _{ISO}	V ₊ = 3V, R _L = 50Ω, Signal = 0dBm, Test Circuit 5	10MHz	+25°C		-45	dB
			1MHz	+25°C		-65	
-3dB Bandwidth	BW	V ₊ = 3V, Signal = 0dBm, R _L = 50Ω, Test Circuit 6	+25°C		90		MHz
Channel On Capacitance	C _{NC(ON)} , C _{NO(ON)} , C _{COM(ON)}	V ₊ = 3V, f = 1MHz	+25°C		40		pF
Channel Off Capacitance	C _{NC(OFF)} , C _{NO(OFF)} , C _{COM(OFF)}	V ₊ = 3V, f = 1MHz	+25°C		8.5		pF
POWER REQUIREMENTS							
Power Supply Current	I ₊	V ₊ = 3.6V, V _{IN} = 0V or V ₊	+25°C		0.1		μA

TEST CIRCUITS

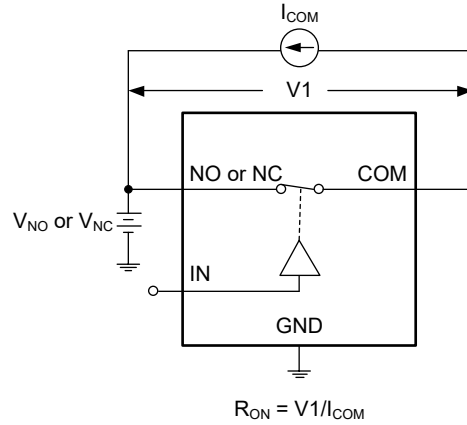

Test Circuit 1. On-Resistance

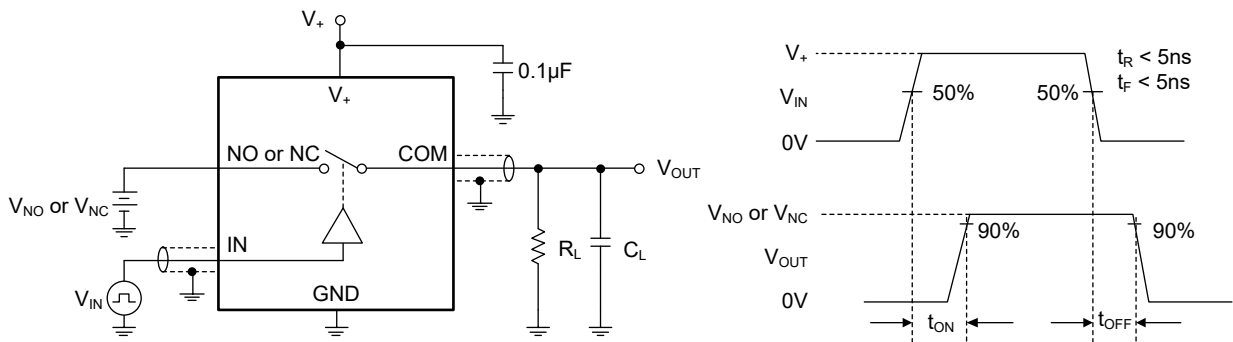

Test Circuit 2. Switching Times (t_{ON} , t_{OFF})

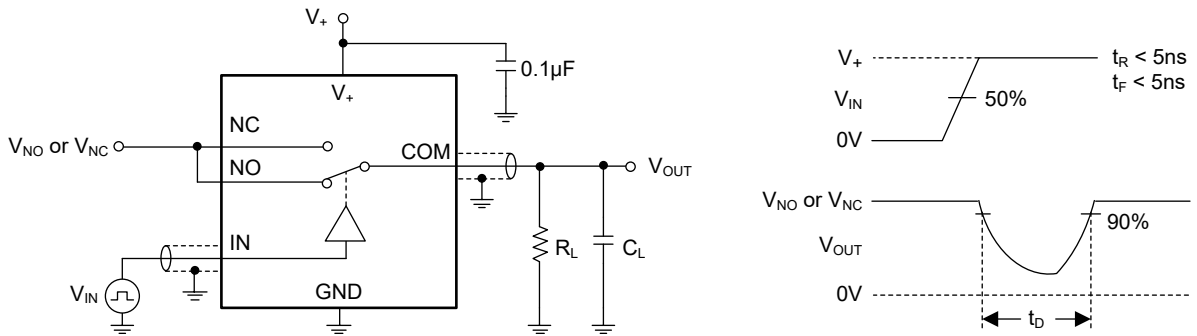

Test Circuit 3. Break-Before-Make Time Delay (t_D)

TEST CIRCUITS (continued)

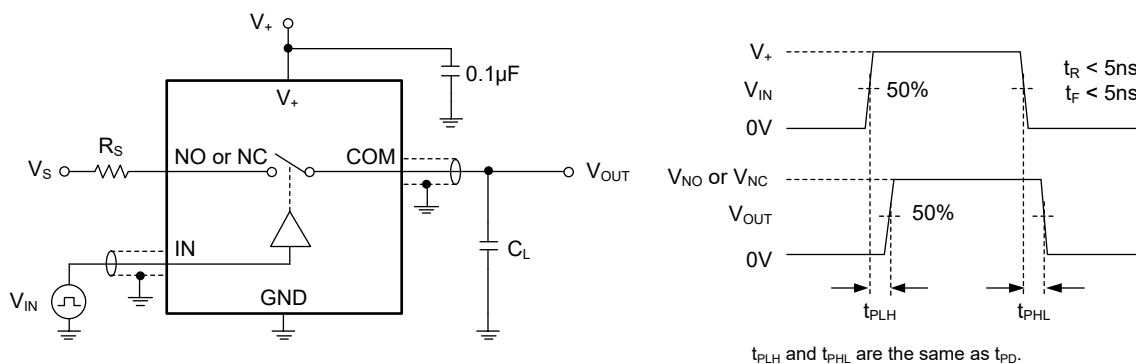

Test Circuit 4. Propagation Delay Time (t_{PD})

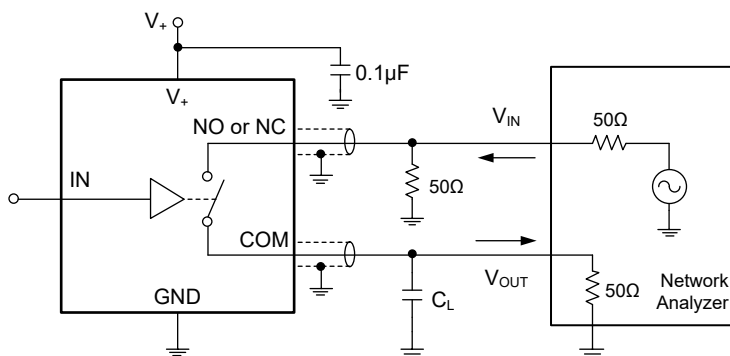

Test Circuit 5. Off Isolation

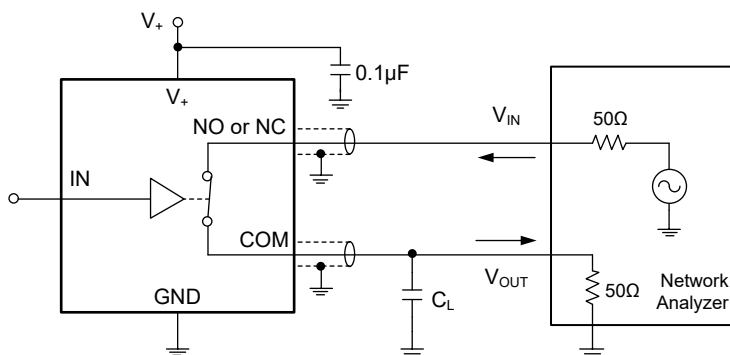

Test Circuit 6. -3dB Bandwidth

REVISION HISTORY

NOTE: Page numbers for previous revisions may differ from page numbers in the current version.

DECEMBER 2018 – REV.C to REV.C.1

Updated SC70-6 package marking information..... 2

JULY 2014 – REV.B.4 to REV.C

Updated Absolute Maximum Ratings section..... 2

JANUARY 2013 – REV.B.3 to REV.B.4

Added Recommended Land Pattern section..... 7

Added Tape and Reel Information section..... 8, 9

MAY 2011 – REV.B.2 to REV.B.3

Updated Package Name..... 2, 7

DECEMBER 2010 – REV. B.1 to REV.B.2

Changed the input low voltage maximum value from 0.6V to 0.4V..... 3

OCTOBER 2010 – REV.B to REV.B.1

Added the maximum values of some parameters 3, 4

JUNE 2010 – REV.A.1 to REV.B

New Version..... All

DECEMBER 2008 – REV.A.1 to REV.A.1

Changed the datasheet to new SGMICRO format All

MAY 2008 – REV.A to REV.A.1

Changed Electrical Characteristics section 2, 3

Changed Test Circuits section 6, 7

Changes from Original (January 2008) to REV.A

Changed from product preview to production data..... All

PACKAGE OUTLINE DIMENSIONS

SC70-6

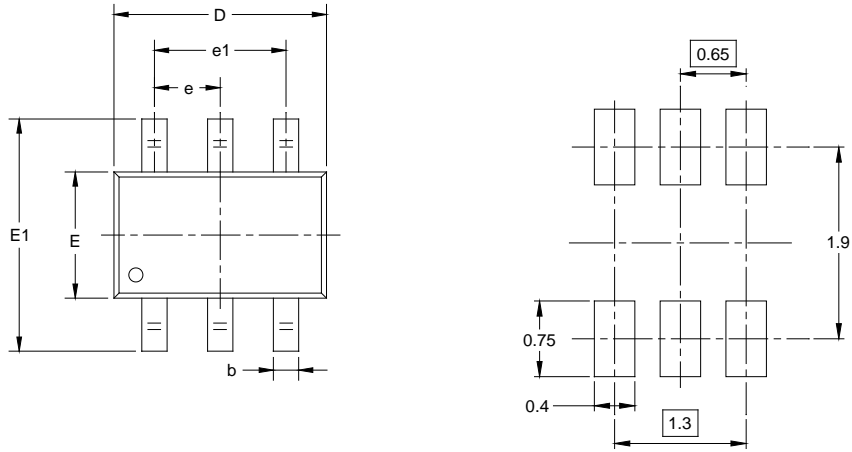

RECOMMENDED LAND PATTERN (Unit: mm)

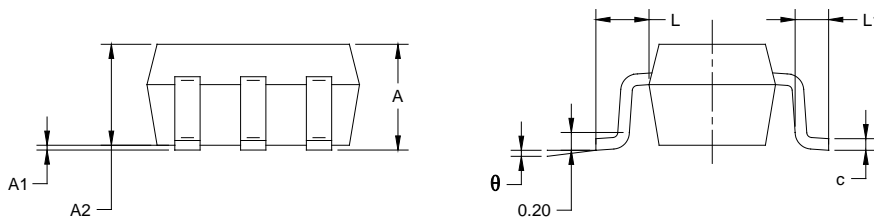

Symbol	Dimensions In Millimeters		Dimensions In Inches	
	MIN	MAX	MIN	MAX
A	0.800	1.100	0.031	0.043
A1	0.000	0.100	0.000	0.004
A2	0.800	1.000	0.031	0.039
b	0.150	0.350	0.006	0.014
c	0.080	0.220	0.003	0.009
D	2.000	2.200	0.079	0.087
E	1.150	1.350	0.045	0.053
E1	2.150	2.450	0.085	0.096
e	0.65 TYP		0.026 TYP	
e1	1.300 BSC		0.051 BSC	
L	0.525 REF		0.021 REF	
L1	0.260	0.460	0.010	0.018
θ	0°	8°	0°	8°

PACKAGE INFORMATION

TAPE AND REEL INFORMATION

REEL DIMENSIONS



TAPE DIMENSIONS



NOTE: The picture is only for reference. Please make the object as the standard.

KEY PARAMETER LIST OF TAPE AND REEL

Package Type	Reel Diameter	Reel Width W1 (mm)	A0 (mm)	B0 (mm)	K0 (mm)	P0 (mm)	P1 (mm)	P2 (mm)	W (mm)	Pin1 Quadrant
SC70-6	7"	9.5	2.40	2.50	1.20	4.0	4.0	2.0	8.0	Q3

000001

PACKAGE INFORMATION

CARTON BOX DIMENSIONS

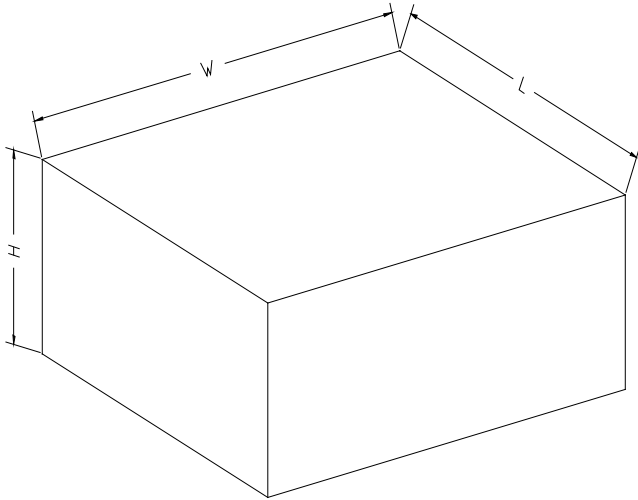

NOTE: The picture is only for reference. Please make the object as the standard.

KEY PARAMETER LIST OF CARTON BOX

Reel Type	Length (mm)	Width (mm)	Height (mm)	Pizza/Carton
7" (Option)	368	227	224	8
7"	442	410	224	18

DD0002

单击下面可查看定价，库存，交付和生命周期等信息

[>>SGMICRO\(圣邦微电子\)](#)