



# SGM6013

## 1.6MHz, 800mA Synchronous Step-Down Converter

### GENERAL DESCRIPTION

The SGM6013 is a 1.6MHz constant frequency, current mode, synchronous, step-down switching regulator. It can deliver 800mA load current from 2.5V to 5.5V input voltage, and the output voltage can be as low as 0.6V.

The high switching frequency minimizes the sizes of inductor and capacitor. Integrated power MOSFETs and internal compensation make the SGM6013 simple to use and fit the total solution in a compact space.

The SGM6013 can operate at a low dropout for the 100% duty cycle, which can conserve the battery life of portable devices. The synchronous architecture eliminates the external Schottky diode, and achieves over 90% of the power conversion efficiency. With low output ripple voltage at light load, the 30 $\mu$ A quiescent current and less than 1 $\mu$ A shutdown current make SGM6013 the ideal power supply solution for portable applications.

SGM6013 is available in both adjustable and fixed (1.2V, 1.8V, 3.3V) output voltage versions. It is available in Green TSOT-23-5 and TDFN-2 $\times$ 2-6L packages. It is rated over the -40 °C to +85 °C temperature range.

### FEATURES

- 2.5V to 5.5V Input Voltage Range
- Up to 95% High Efficiency
- 30 $\mu$ A Low Quiescent Current at Light Load
- 800mA Output Current
- 1.2V, 1.8V, 3.3V Fixed & Adjustable Output Voltages
- 0.6V Reference Voltage
- 1.6MHz Constant Switching Frequency
- Less than 1 $\mu$ A Shutdown Current
- 100% Duty Cycle for Lowest Dropout
- No External Power MOSFETs and Schottky Diode Required
- Excellent Line Regulation & Load Transient Response
- -40°C to +85°C Operating Temperature Range
- Available in Green TSOT-23-5 and TDFN-2 $\times$ 2-6L Packages

### APPLICATIONS

GPS  
Mobile Phones  
E-book Readers  
Digital Cameras  
Portable Instruments  
Wireless and DSL Modems  
Battery Powered Equipment  
Supply for Microprocessor, DSP

**PACKAGE/ORDERING INFORMATION**

MODEL	V <sub>OUT</sub> (V)	PACKAGE DESCRIPTION	SPECIFIED TEMPERATURE RANGE	ORDERING NUMBER	PACKAGE MARKING	PACKING OPTION
SGM6013	1.2V	TSOT-23-5	-40°C to +85°C	SGM6013-1.2YTN5G/TR	SC1XX	Tape and Reel, 3000
	1.8V	TSOT-23-5	-40°C to +85°C	SGM6013-1.8YTN5G/TR	SH5XX	Tape and Reel, 3000
	3.3V	TSOT-23-5	-40°C to +85°C	SGM6013-3.3YTN5G/TR	SH6XX	Tape and Reel, 3000
	Adjustable	TSOT-23-5	-40°C to +85°C	SGM6013-ADJYTN5G/TR	SC2XX	Tape and Reel, 3000
	Adjustable	TDFN-2×2-6L	-40°C to +85°C	SGM6013-ADJYTDI6G/T R	SC2 XXXX	Tape and Reel, 3000

**MARKING INFORMATION**

NOTE: XX = Date Code, Trace Code and Vendor Code.

**SYX X**

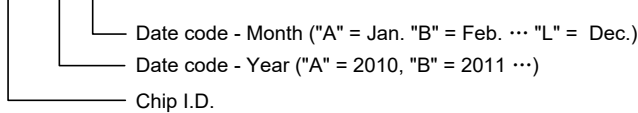

For example: SBFCA (2012, January)

Green (RoHS & HSF): SG Micro Corp defines "Green" to mean Pb-Free (RoHS compatible) and free of halogen substances. If you have additional comments or questions, please contact your SGMICRO representative directly.

**ABSOLUTE MAXIMUM RATINGS**

Input Supply Voltage.....	-0.3V to 6V
RUN, V <sub>FB</sub> Voltages.....	-0.3V to V <sub>IN</sub>
SW Voltage.....	-0.3V to (V <sub>IN</sub> + 0.3V)
Package Thermal Resistance	
TSOT-23-5, θ <sub>JA</sub> .....	200°C/W
TDFN-2×2-6L, θ <sub>JA</sub> .....	200°C/W
P-Channel Switch Source Current (DC).....	800mA
N-Channel Switch Sink Current (DC).....	800mA
Peak SW Sink and Source Current.....	1.3A
Operating Temperature Range.....	-40°C to +85°C
Junction Temperature.....	150°C
Storage Temperature Range.....	-65°C to +150°C
Lead Temperature (Soldering, 10s) .....	260°C
ESD Susceptibility	
HBM.....	4000V
MM.....	300V

**RECOMMENDED OPERATING CONDITIONS**

Operating Temperature Range .....	-40°C to +85°C
-----------------------------------	----------------

**OVERSTRESS CAUTION**

Stresses beyond those listed in Absolute Maximum Ratings may cause permanent damage to the device. Exposure to absolute maximum rating conditions for extended periods may affect reliability. Functional operation of the device at any conditions beyond those indicated in the Recommended Operating Conditions section is not implied.

**ESD SENSITIVITY CAUTION**

This integrated circuit can be damaged if ESD protections are not considered carefully. SGMICRO recommends that all integrated circuits be handled with appropriate precautions. Failure to observe proper handling and installation procedures can cause damage. ESD damage can range from subtle performance degradation to complete device failure. Precision integrated circuits may be more susceptible to damage because even small parametric changes could cause the device not to meet the published specifications.

**DISCLAIMER**

SG Micro Corp reserves the right to make any change in circuit design, or specifications without prior notice.

## PIN CONFIGURATION

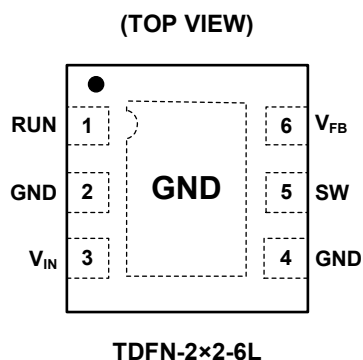
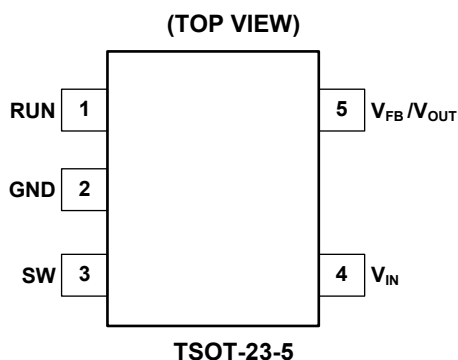

## PIN DESCRIPTION

PIN		NAME	FUNCTION
TSOT-23-5	TDFN-2x2-6L		
1	3	$V_{IN}$	Supply Voltage Pin. A 4.7 $\mu$ F ceramic capacitor or greater is used to closely decouple this pin to GND.
2	2, 4	GND	Ground.
3	1	RUN	Control Input. More than 1.5V input enables the device. Less than 0.3V input shuts down the device. In shutdown, all functions stopped with the drawing supply current less than 1 $\mu$ A. Do not leave it floating.
4	6	$V_{FB}$	Feedback Pin. This pin receives the feedback voltage from an external resistive divider across the output. For adjustable version, the internal voltage divider is disabled. (SGM6013-ADJ)
	—	$V_{OUT}$	Output Voltage Feedback Pin. The internal resistor divider divides the output voltage for comparison with the internal reference voltage. (SGM6013-1.2/SGM6013-1.8/SGM6013-3.3)
5	5	SW	Switch Node. Put an inductor to this pin and connects to the drains of the internal main and synchronous power MOSFET switches.

## ELECTRICAL CHARACTERISTICS

( $V_{IN} = 3.6V$ ,  $L = 2.2\mu H$ ,  $C_{IN} = 4.7\mu F$ ,  $C_{OUT} = 10\mu F$ , Full =  $-40^{\circ}C$  to  $+85^{\circ}C$ , typical values are at  $T_A = +25^{\circ}C$ , unless otherwise noted.)

PARAMETER		SYMBOL	CONDITIONS	TEMP	MIN	TYP	MAX	UNITS	
Input Voltage Range		$V_{IN}$		Full	2.5		5.5	V	
Feedback Current		$I_{VFB}$		Full		$\pm 1$	$\pm 100$	nA	
Regulated Feedback Voltage		$V_{FB}$		Full	0.580	0.600	0.622	V	
				$+25^{\circ}C$	0.583	0.600	0.620		
				$0^{\circ}C \leq T_A \leq +85^{\circ}C$	0.582	0.600	0.621		
Reference Voltage Line Regulation		$\Delta V_{FB}$	$V_{IN} = 2.5V$ to $5.5V$	Full		0.1	0.6	%/V	
Regulated Output Voltage		$V_{OUT}$	SGM6013-1.2	$I_{OUT} = 100mA$	Full	1.159	1.200	1.241	V
			SGM6013-1.8	$I_{OUT} = 100mA$		1.739	1.800	1.861	
			SGM6013-3.3	$I_{OUT} = 100mA$		3.188	3.300	3.412	
Output Voltage Line Regulation		$\Delta V_{OUT}$	$V_{IN} = 2.5V$ to $5.5V$	Full		0.1	0.6	%/V	
Peak Inductor Current		$I_{PK}$	$V_{FB} = 0.5V$ or $V_{OUT} = 90\%$ , $V_{IN} = 3V$	$+25^{\circ}C$		1	1.25	A	
Output Voltage Load Regulation		$V_{LOADREG}$		$+25^{\circ}C$		0.5		%	
SW Leakage Current		$I_{SW}$	$V_{RUN} = 0V$ , $V_{SW} = 0V$ or $5V$ , $V_{IN} = 5V$	$+25^{\circ}C$		$\pm 0.01$	$\pm 1$	$\mu A$	
Supply Current	PWM Mode	$I_S$	$V_{FB} = 0.5V$ or $V_{OUT} = 90\%$ , $I_{LOAD} = 0A$	$+25^{\circ}C$		280	360	$\mu A$	
	PFM Mode		$V_{FB} = 0.62V$ or $V_{OUT} = 103\%$ , $I_{LOAD} = 0A$			30	56		
	Shutdown		$V_{RUN} = 0V$ , $V_{IN} = 4.2V$			0.1	1		
RUN Threshold		$V_{IH}$		Full	1.5			V	
		$V_{IL}$					0.3		
RUN Leakage Current		$I_{RUN}$		Full		$\pm 0.01$	$\pm 1$	$\mu A$	
Oscillator Frequency		$f_{OSC}$	$V_{FB} = 0.6V$ or $V_{OUT} = 100\%$	Full	1.3	1.6	1.9	MHz	
			$V_{FB} = 0V$ or $V_{OUT} = 0V$	$+25^{\circ}C$		200			kHz
R <sub>DS(ON)</sub> of P-Channel FET		$R_{PFET}$	$I_{SW} = 100mA$	$+25^{\circ}C$		0.46	0.65	$\Omega$	
R <sub>DS(ON)</sub> of N-Channel FET		$R_{NFET}$	$I_{SW} = -100mA$	$+25^{\circ}C$		0.36	0.56	$\Omega$	
PFM/PWM Mode Switch Point				$+25^{\circ}C$		40		mA	

TYPICAL PERFORMANCE CHARACTERISTICS

T<sub>A</sub> = +25°C, L = 2.2µH, C<sub>IN</sub> = 4.7µF, C<sub>OUT</sub> = 10µF, unless otherwise noted.

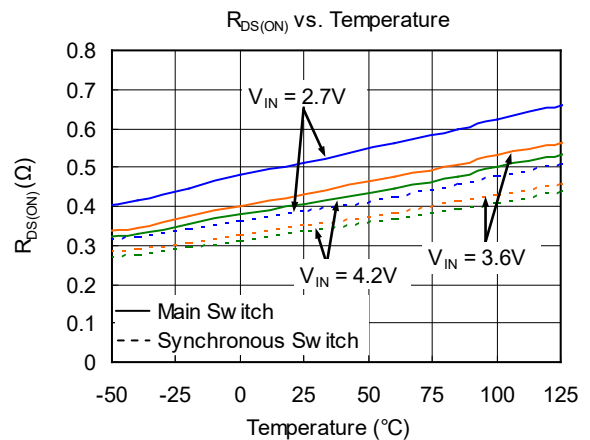
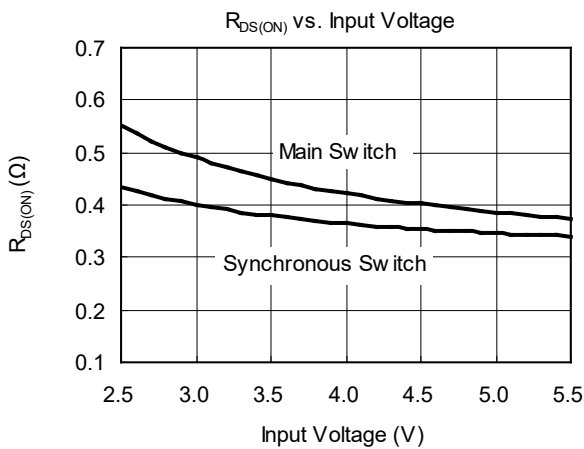
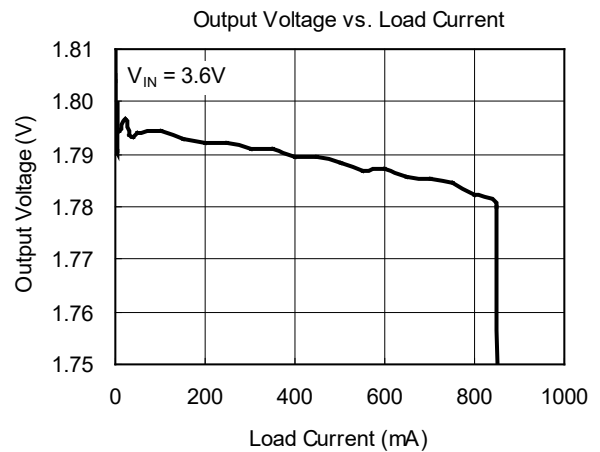
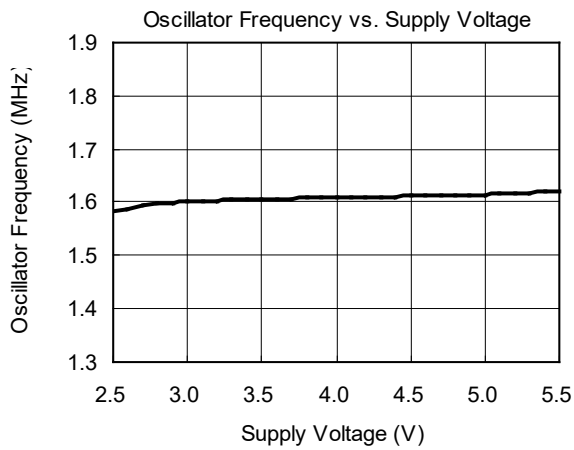
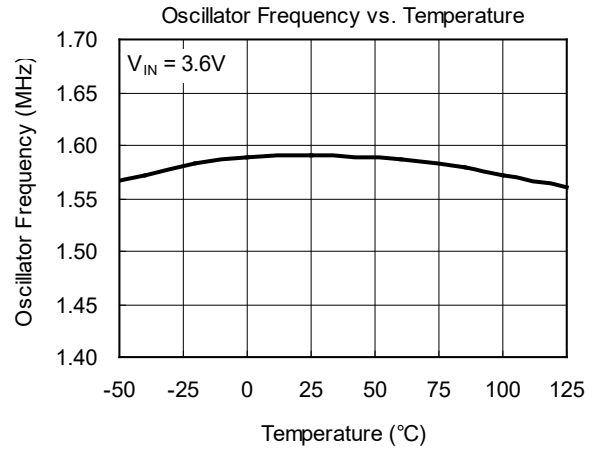
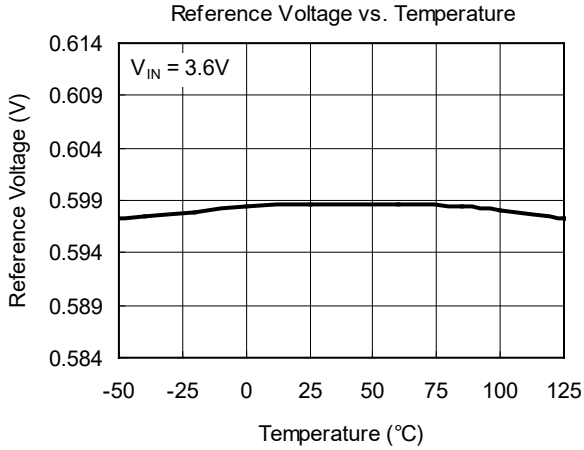

TYPICAL PERFORMANCE CHARACTERISTICS (continued)

T<sub>A</sub> = +25°C, L = 2.2µH, C<sub>IN</sub> = 4.7µF, C<sub>OUT</sub> = 10µF, unless otherwise noted.

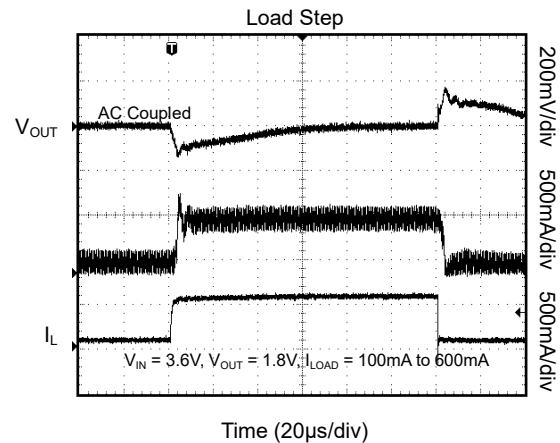
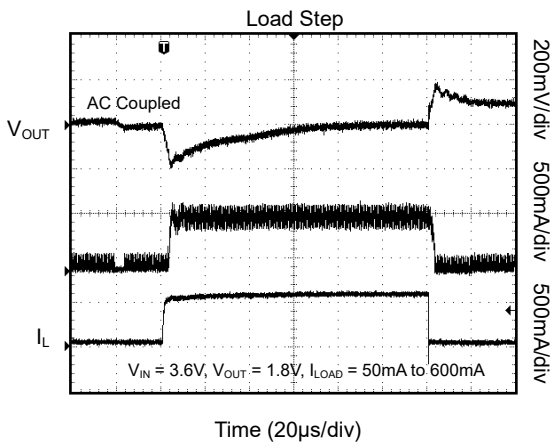
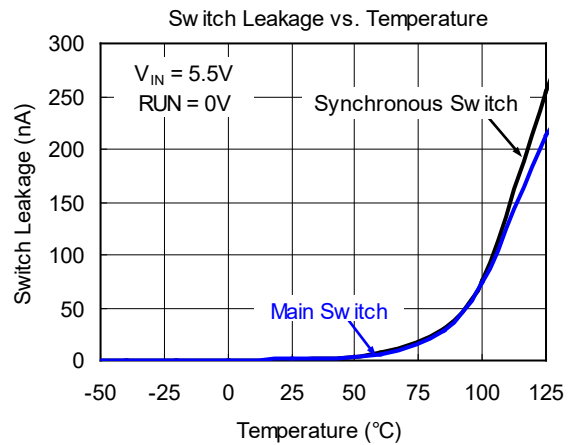
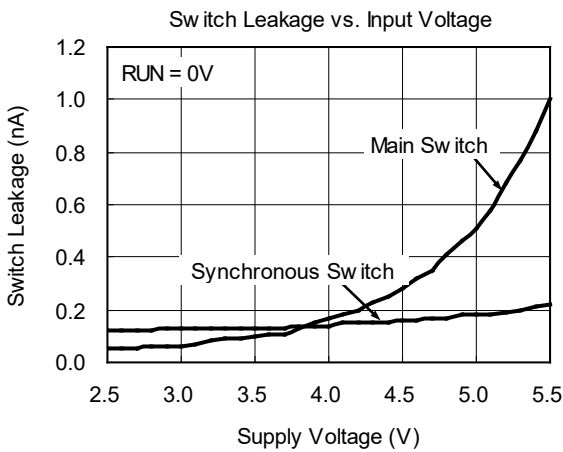
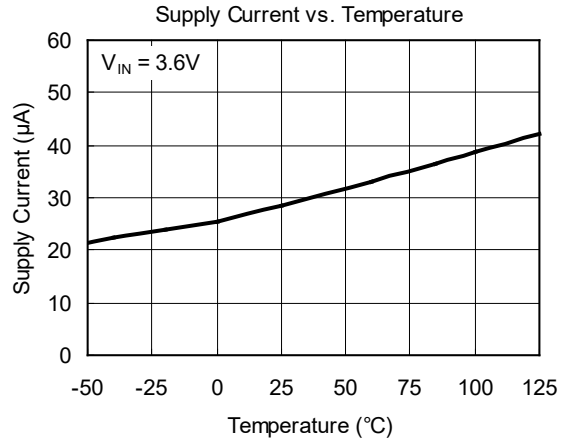
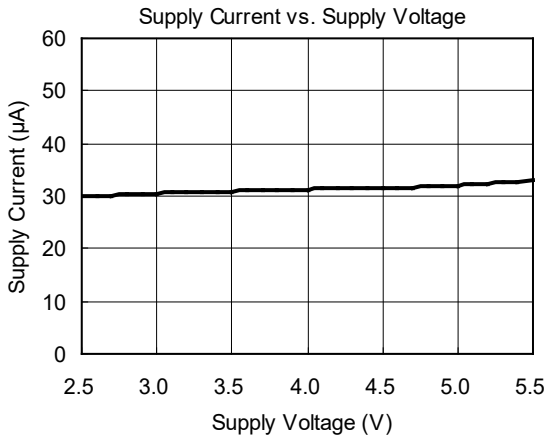

TYPICAL PERFORMANCE CHARACTERISTICS (continued)

T<sub>A</sub> = +25°C, L = 2.2µH, C<sub>IN</sub> = 4.7µF, C<sub>OUT</sub> = 10µF, unless otherwise noted.

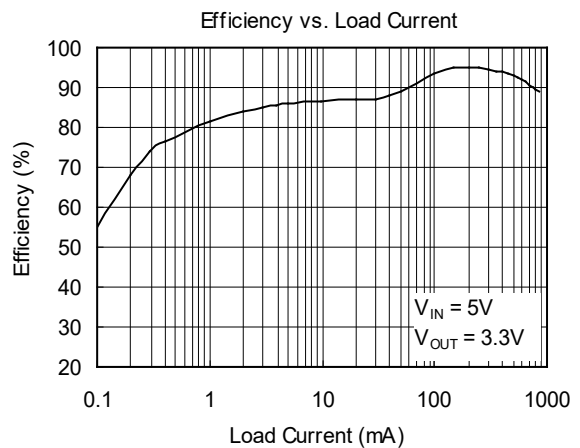
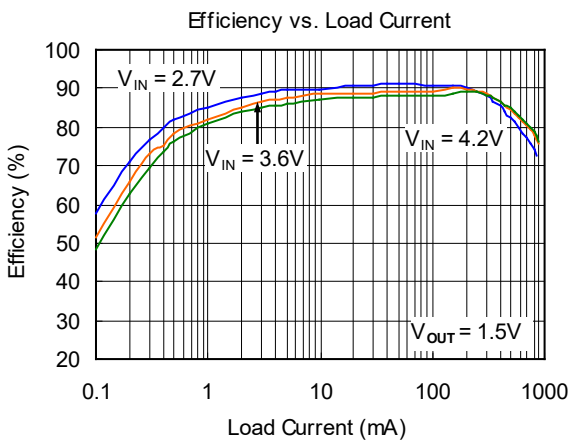
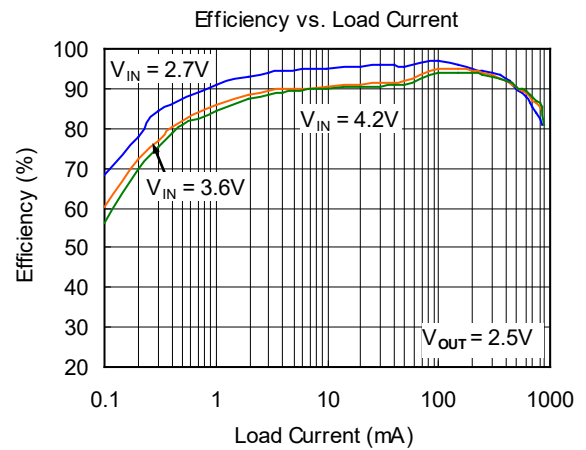
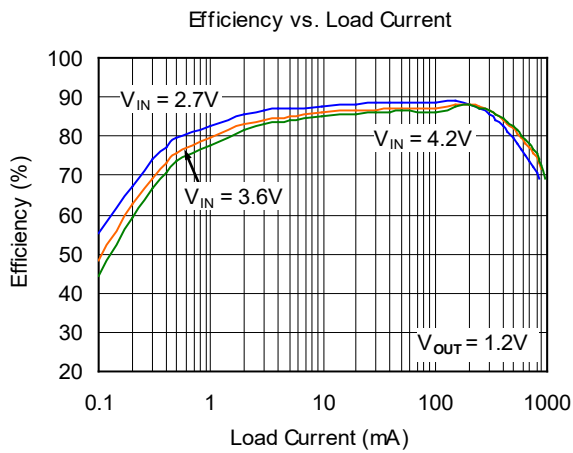
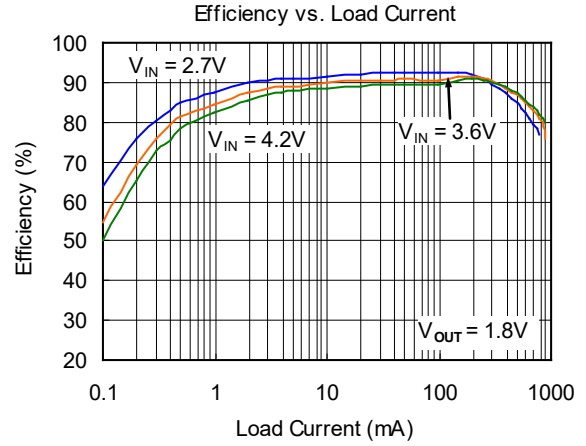
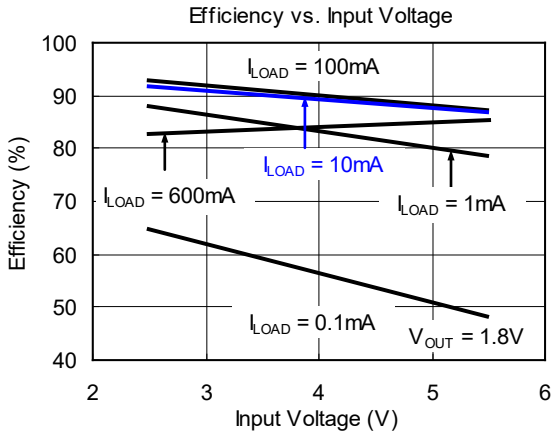

TYPICAL PERFORMANCE CHARACTERISTICS (continued)

T<sub>A</sub> = +25°C, L = 2.2μH, C<sub>IN</sub> = 4.7μF, C<sub>OUT</sub> = 10μF, unless otherwise noted.

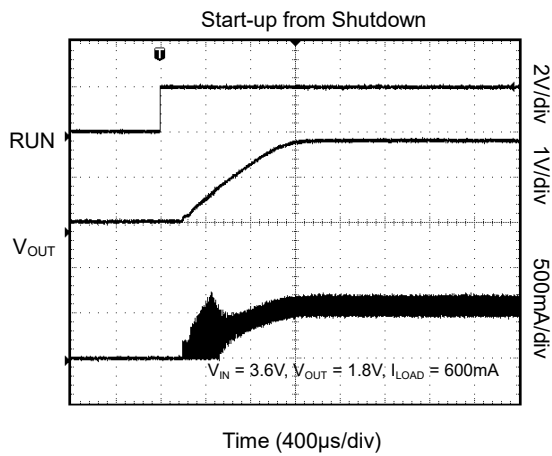
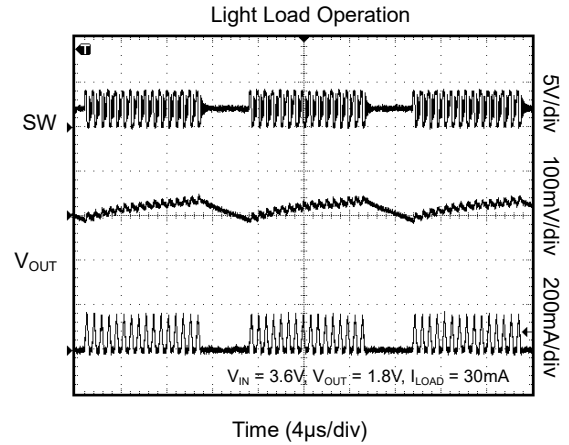
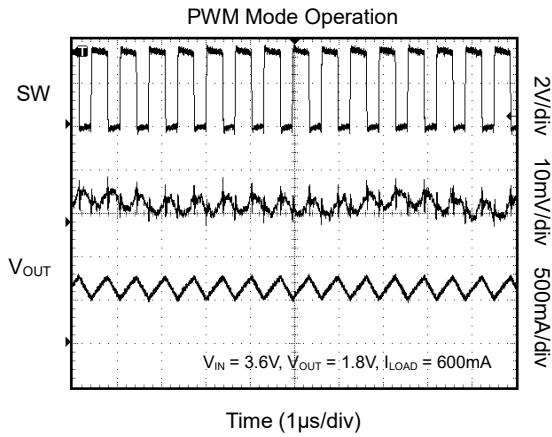



PCB LAYOUT

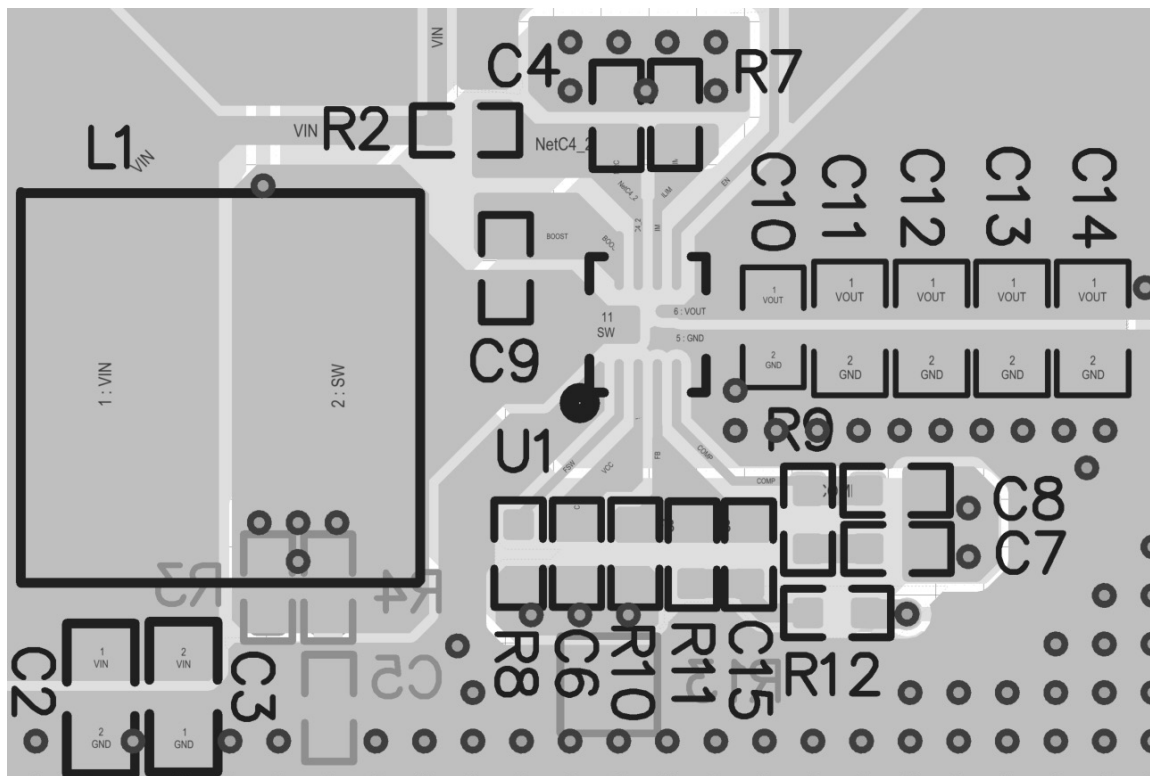

Figure 1. Layout Example

**REVISION HISTORY**

NOTE: Page numbers for previous revisions may differ from page numbers in the current version.

<b>MARCH 2016 – REV.A to REV.A.1</b>	<b>Page</b>
Updated Electrical Characteristics section .....	4
Changed load current (600mA to 800mA).....	All

---

<b>Changes from Original (NOVEMBER 2013) to REV.A</b>	<b>Page</b>
Changed from product preview to production data.....	All

---

PACKAGE OUTLINE DIMENSIONS

TSOT-23-5

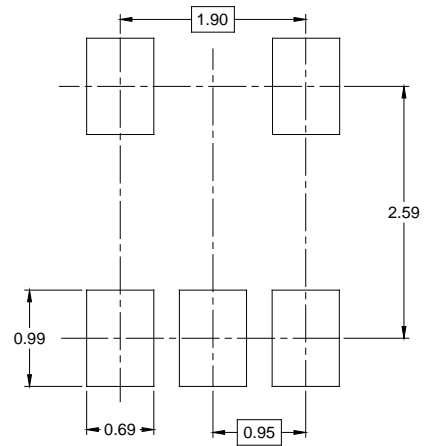
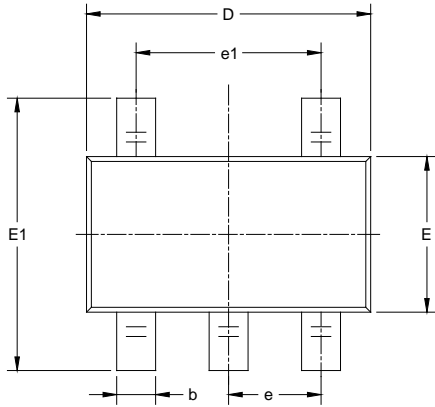

RECOMMENDED LAND PATTERN (Unit: mm)

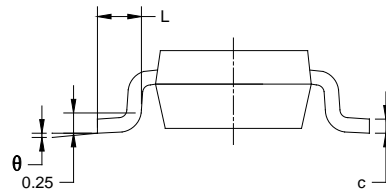
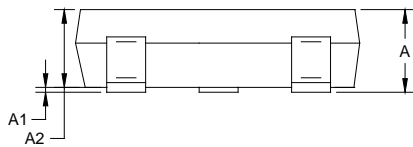

Symbol	Dimensions In Millimeters		Dimensions In Inches	
	MIN	MAX	MIN	MAX
A	0.700	0.900	0.028	0.035
A1	0.000	0.100	0.000	0.004
A2	0.700	0.800	0.028	0.031
b	0.350	0.500	0.014	0.020
c	0.080	0.200	0.003	0.008
D	2.820	3.020	0.111	0.119
E	1.600	1.700	0.063	0.067
E1	2.650	2.950	0.104	0.116
e	0.950 BSC		0.037 BSC	
e1	1.900 BSC		0.075 BSC	
L	0.300	0.600	0.012	0.024
$\theta$	0°	8°	0°	8°

NOTES:

1. Body dimensions do not include mode flash or protrusion.
2. This drawing is subject to change without notice.

PACKAGE OUTLINE DIMENSIONS

TDFN-2x2-6L

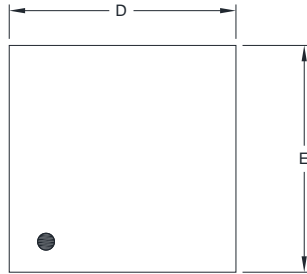

TOP VIEW

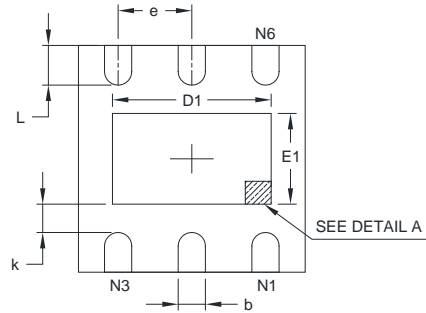

BOTTOM VIEW



SIDE VIEW

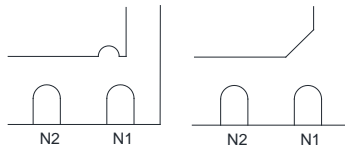

DETAIL A

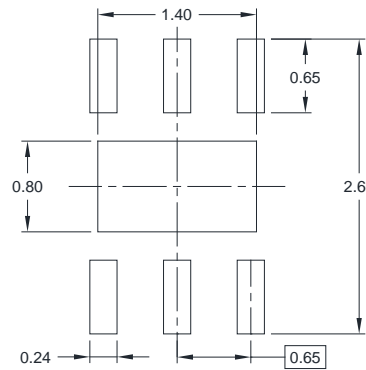

RECOMMENDED LAND PATTERN (Unit: mm)

Pin #1 ID and Tie Bar Mark Options

NOTE: The configuration of the Pin #1 identifier is optional, but must be located within the zone indicated.

Symbol	Dimensions In Millimeters		Dimensions In Inches	
	MIN	MAX	MIN	MAX
A	0.700	0.800	0.028	0.031
A1	0.000	0.050	0.000	0.002
A2	0.203 REF		0.008 REF	
D	1.900	2.100	0.075	0.083
D1	1.100	1.450	0.043	0.057
E	1.900	2.100	0.075	0.083
E1	0.600	0.850	0.024	0.034
k	0.200 MIN		0.008 MIN	
b	0.180	0.300	0.007	0.012
e	0.650 TYP		0.026 TYP	
L	0.250	0.450	0.010	0.018

NOTE: This drawing is subject to change without notice.

TAPE AND REEL INFORMATION

REEL DIMENSIONS

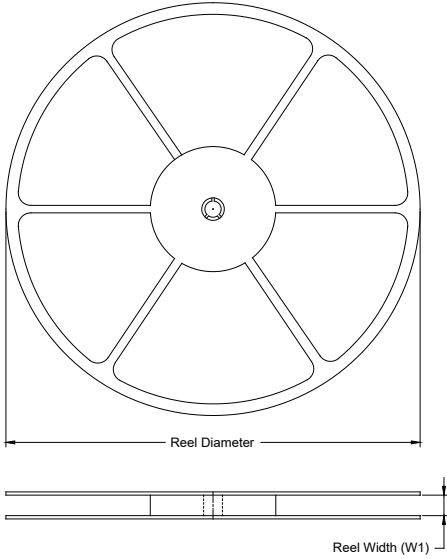

TAPE DIMENSIONS



NOTE: The picture is only for reference. Please make the object as the standard.

KEY PARAMETER LIST OF TAPE AND REEL

Package Type	Reel Diameter	Reel Width W1 (mm)	A0 (mm)	B0 (mm)	K0 (mm)	P0 (mm)	P1 (mm)	P2 (mm)	W (mm)	Pin1 Quadrant
TSOT-23-5	7"	9.5	3.17	3.10	1.10	4.0	4.0	2.0	8.0	Q3
TDFN-2x2-6L	7"	9.5	2.30	2.30	1.10	4.0	4.0	2.0	8.0	Q1

DD0001

# PACKAGE INFORMATION

## CARTON BOX DIMENSIONS



NOTE: The picture is only for reference. Please make the object as the standard.

## KEY PARAMETER LIST OF CARTON BOX

Reel Type	Length (mm)	Width (mm)	Height (mm)	Pizza/Carton
7" (Option)	368	227	224	8
7"	442	410	224	18

DD0002

单击下面可查看定价，库存，交付和生命周期等信息

[>>SGMICRO\(圣邦微电子\)](#)