

GENERAL DESCRIPTION

The SGM42633 is a motor driver device with two integrated H-bridges that can run a bipolar stepper motor. The device can operate over a wide input voltage range of 2.5V to 12V, and each H-bridge of the SGM42633 can deliver up to 700mA RMS (or DC) continuously (at $V_{CC} = 5V$, $T_J = +25^{\circ}C$).

Internal over-current and over-temperature circuits prevent the device from being in over-stress condition, while a fault output simplifies stalling sensing, which is a useful feature for most applications. Aiming for battery-powered applications, it can go into low-power mode for increased battery life.

The device is available in Green TQFN-3×3-16L and TSSOP-16 (Exposed Pad) packages.

APPLICATIONS

Robotics
Point-of-Sale Printers
Portable Printers
Toys
Video Security Cameras

FEATURES

- **Power Supply Voltage Range: 2.5V to 12V**
- **Dual H-Bridge Motor Driver**
- **Low Quiescent Current: 150 μ A (TYP)**
- **Sleep Mode Supply Current: 0.32 μ A (TYP)**
- **xINx (PWM) Interface**
- **Output Current Capability (at $V_{CC} = 5V$, $+25^{\circ}C$)**
 - ◆ **TSSOP Package:**
 - 0.7A RMS, 1A Peak per H-Bridge**
 - 1.4A RMS in Parallel Mode**
 - ◆ **TQFN Package:**
 - 0.6A RMS, 1A Peak per H-Bridge**
 - 1.2A RMS in Parallel Mode**
- **UVLO for VCC Voltage**
- **Over-Current Protection (OCP)**
- **Thermal Shutdown (TSD)**
- **Fault Indication Pin (nFAULT)**
- **Available in Green TSSOP-16 (Exposed Pad) and TQFN-3×3-16L Packages**

PACKAGE/ORDERING INFORMATION

MODEL	PACKAGE DESCRIPTION	SPECIFIED TEMPERATURE RANGE	ORDERING NUMBER	PACKAGE MARKING	PACKING OPTION
SGM42633	TSSOP-16 (Exposed Pad)	-40°C to +125°C	SGM42633XPTS16G/TR	SGM42633 XPTS16 XXXXX	Tape and Reel, 4000
	TQFN-3×3-16L	-40°C to +125°C	SGM42633XTQ16G/TR	42633TQ XXXXX	Tape and Reel, 4000

MARKING INFORMATION

NOTE: XXXXX = Date Code, Trace Code and Vendor Code.

XXXXX

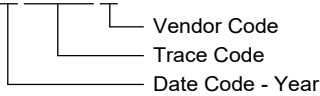

Green (RoHS & HSF): SG Micro Corp defines "Green" to mean Pb-Free (RoHS compatible) and free of halogen substances. If you have additional comments or questions, please contact your SGMICRO representative directly.

ABSOLUTE MAXIMUM RATINGS

- Power Supply Voltage Range, V_{CC} -0.3V to 13.2V
- Control Pins (AIN1, AIN2, BIN1, BIN2, nSLEEP, nFAULT) to GND..... -0.3V to 6V
- Package Thermal Resistance TSSOP-16 (Exposed Pad), θ_{JA} 41°C/W
- TQFN-3×3-16L, θ_{JA}..... 47°C/W
- Operating Junction Temperature.....+150°C
- Storage Temperature Range-65°C to +150°C
- Lead Temperature (Soldering, 10s).....+260°C
- ESD Susceptibility HBM..... 6000V
- CDM 1000V

RECOMMENDED OPERATING CONDITIONS

- Power Supply Voltage Range, V_{CC}2.5V to 12V
- Motor RMS Current, I_{RMS} TSSOP-16 (Exposed Pad) Package.....0A to 0.7A
- TQFN-3×3-16L Package.....0A to 0.6A
- Applied PWM Signal to AIN1, AIN2, BIN1, or BIN2, f_{PWM} 0kHz to 200kHz
- Operating Ambient Temperature Range.....-40°C to +125°C
- Operating Junction Temperature Range.....-40°C to +125°C

OVERSTRESS CAUTION

Stresses beyond those listed in Absolute Maximum Ratings may cause permanent damage to the device. Exposure to absolute maximum rating conditions for extended periods may affect reliability. Functional operation of the device at any conditions beyond those indicated in the Recommended Operating Conditions section is not implied.

ESD SENSITIVITY CAUTION

This integrated circuit can be damaged if ESD protections are not considered carefully. SGMICRO recommends that all integrated circuits be handled with appropriate precautions. Failure to observe proper handling and installation procedures can cause damage. ESD damage can range from subtle performance degradation to complete device failure. Precision integrated circuits may be more susceptible to damage because even small parametric changes could cause the device not to meet the published specifications.

DISCLAIMER

SG Micro Corp reserves the right to make any change in circuit design, or specifications without prior notice.

PIN CONFIGURATIONS

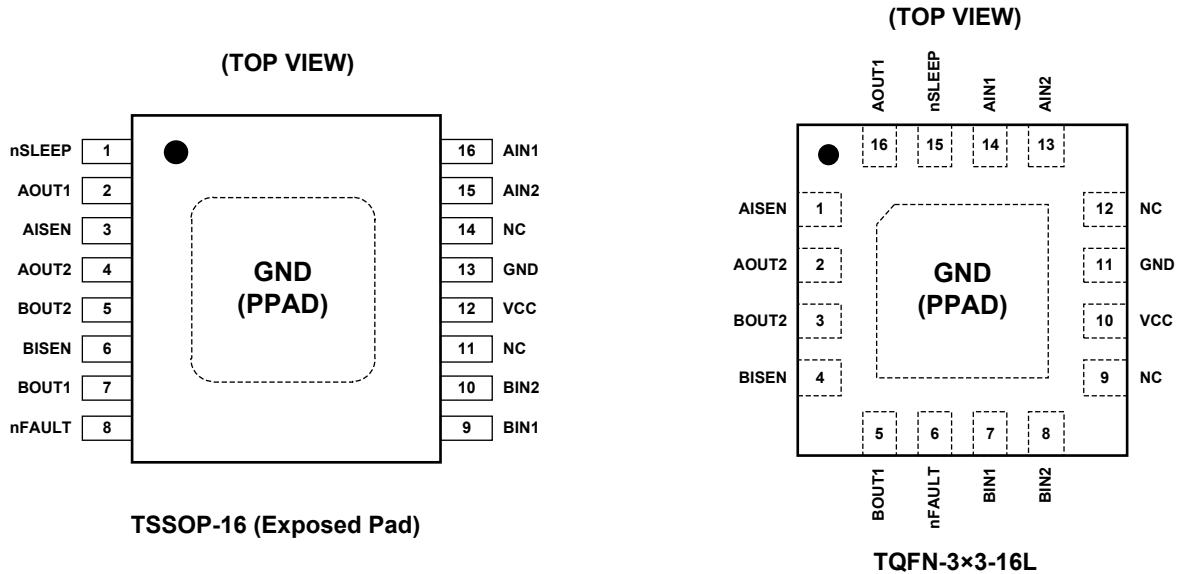

PIN DESCRIPTION

PIN		NAME	TYPE	FUNCTION
TSSOP-16 (Exposed Pad)	TQFN-3x3-16L			
2	16	AOUT1	O	Bridge A Nodes.
4	2	AOUT2		
7	5	BOUT1	O	Bridge B Nodes.
5	3	BOUT2		
16	14	AIN1	I	H-Bridge A PWM Inputs. Control the state of AOUT1 and AOUT2. Internal pull-down.
15	13	AIN2		
9	7	BIN1	I	H-Bridge B PWM Inputs. Control the state of BOUT1 and BOUT2. Internal pull-down.
10	8	BIN2		
1	15	nSLEEP	I	Sleep Mode Input. Apply logic high to enable device, and apply logic low to enter into the low power sleep mode. Internal pull-down.
8	6	nFAULT	OD	Fault Indication Pin. The logic is pulled low with a fault condition. Open-drain output requires an external pull-up.
3	1	AISEN	I/O	Bridge A Ground or I _{CHOP} .
6	4	BISEN	I/O	Bridge B Ground or I _{CHOP} .
12	10	VCC	P	Device Power Supply. Connect to motor supply. A 10µF (MIN) ceramic bypass capacitor to GND is recommended.
13	11	GND	G	Ground.
11, 14	9, 12	NC	-	No Connection.
Exposed Pad	Exposed Pad	GND (PPAD)	G	Exposed Pad. Exposed pad is internally connected to GND. Connect it to a large ground plane to maximize thermal performance. It is not intended as an electrical connection point.

NOTE: I = input, O = output, I/O = input or output, OD = open-drain output, G = ground, P = power for the circuit.

ELECTRICAL CHARACTERISTICS

(V_{CC} = 5V, Full = -40°C to +125°C. Typical values are at T_A = +25°C, unless otherwise noted.)

PARAMETER	SYMBOL	CONDITIONS	TEMP	MIN	TYP	MAX	UNITS
Power Supplies (VCC)							
Power Supply Voltage	V _{CC}		Full	2.5		12	V
Power Supply Current	I _{VCC}	xINx low, nSLEEP high	+25°C		150	220	μA
			Full			230	
Sleep Mode Supply Current	I _{VCCQ}	nSLEEP low	+25°C		0.32	0.6	μA
			Full			5	
Time to Enter Sleep Mode	t _{SLEEP}	nSLEEP low to sleep mode	+25°C		10		μs
Wake-Up Time	t _{WAKE}	nSLEEP high to output transition	+25°C		100		μs
Turn-On Time	t _{ON}	V _{CC} > V _{UVLO} to output transition	+25°C		30		μs
Control Inputs (AIN1, AIN2, BIN1, BIN2 and nSLEEP)							
Input Logic Low Voltage	V _{IL}	xINx	Full	0		0.5	V
		nSLEEP	Full	0		0.5	
Input Logic High Voltage	V _{IH}	xINx	Full	1.5		5.5	V
		nSLEEP	Full	1.5		5.5	
Input Logic Hysteresis	V _{HYS}		+25°C		200		mV
Input Logic Low Current	I _{IL}	V _{IN} = 0V	+25°C	-0.5	0.01	0.5	μA
			Full	-1		1	
Input Logic High Current	I _{IH}	xINx, V _{IN} = 5V	+25°C		33	45	μA
			Full			52	
		nSLEEP, V _{IN} = 5V	+25°C		10	14	
			Full			17	
Pull-Down Resistance	R _{PD}	xINx	+25°C	110	150	190	kΩ
			Full	80		220	
		nSLEEP	+25°C	380	500	620	
			Full	280		730	
Input Deglitch Time	t _{DEG}		+25°C		610		ns
Propagation Delay INx to OUTx	t _{PROP}		+25°C		800		ns
Control Output (nFAULT)							
Output Logic Low Voltage	V _{OL}	I _O = 5mA	+25°C		0.22	0.3	V
			Full			0.35	
Output Logic High Leakage Current	I _{OH}	R _{PULLUP} = 1kΩ to 5V	+25°C	-1	0.01	1	μA
			Full	-2		2	

ELECTRICAL CHARACTERISTICS (continued)(V_{CC} = 5V, Full = -40°C to +125°C. Typical values are at T_A = +25°C, unless otherwise noted.)

PARAMETER	SYMBOL	CONDITIONS	TEMP	MIN	TYP	MAX	UNITS
Motor Driver Outputs (AOUT1, AOUT2, BOUT1 and BOUT2)							
High-side FET On-Resistance	R _{DSON_H}	V _{CC} = 5V, I = 0.2A	+25°C		1120	1450	mΩ
			Full			2000	
		V _{CC} = 2.5V, I = 0.2A	+25°C		1480	1850	
			Full			2460	
Low-side FET On-Resistance	R _{DSON_L}	V _{CC} = 5V, I = -0.2A	+25°C		490	610	mΩ
			Full			820	
		V _{CC} = 2.5V, I = -0.2A	+25°C		655	900	
			Full			1150	
Off-State Leakage Current	I _{OFF}		+25°C	-0.5	0.01	0.5	μA
			Full	-1.5		1.5	
Output Rise Time	t _{RISE}	R _L = 16Ω to GND	+25°C		70		ns
Output Fall Time	t _{FALL}	R _L = 16Ω to V _{CC}	+25°C		60		ns
Output Dead Time	t _{DEAD}	Internal dead time	+25°C		90		ns
PWM Current Controls (AISEN and BISEN)							
xISEN Trip Voltage	V _{TRIP}		+25°C	185	202	219	mV
			Full	180		224	
Current Control Constant Off-Time	t _{OFF}	Internal PWM constant off-time	+25°C		25		μs
Protection Circuits							
VCC Under-Voltage Lockout	V _{UVLO}	V _{CC} falling, UVLO report	+25°C	2.02	2.1		V
			Full	2			
		V _{CC} rising, UVLO recovery	+25°C		2.3	2.42	
			Full			2.45	
VCC Under-Voltage Hysteresis	V _{UVLO_HYS}	Rising to falling threshold	+25°C		200		mV
Over-Current Protection Trip Level	I _{OCP}		+25°C	1.01	1.5		A
Over-Current Deglitch Time	t _{DEG}		+25°C		2.6		μs
Over-Current Protection Period	t _{OCP}		+25°C		2.3		ms
Thermal Shutdown Temperature	T _{TSD}				160		°C
Thermal Shutdown Hysteresis	T _{HYS}				20		°C

TYPICAL PERFORMANCE CHARACTERISTICS

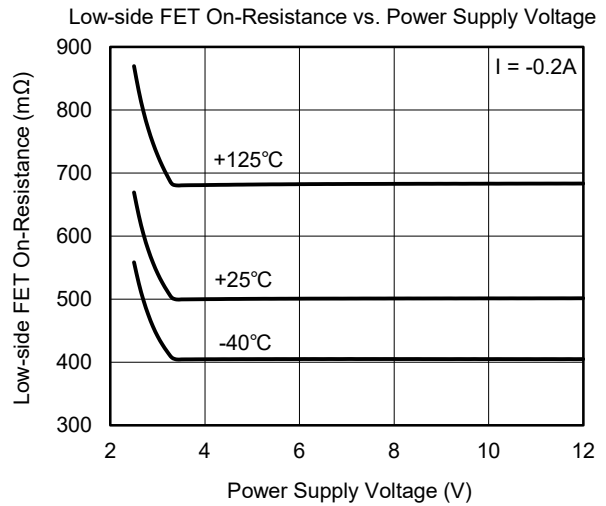
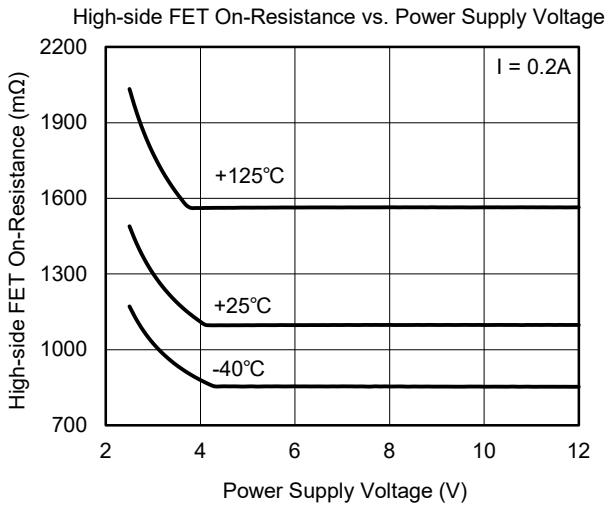
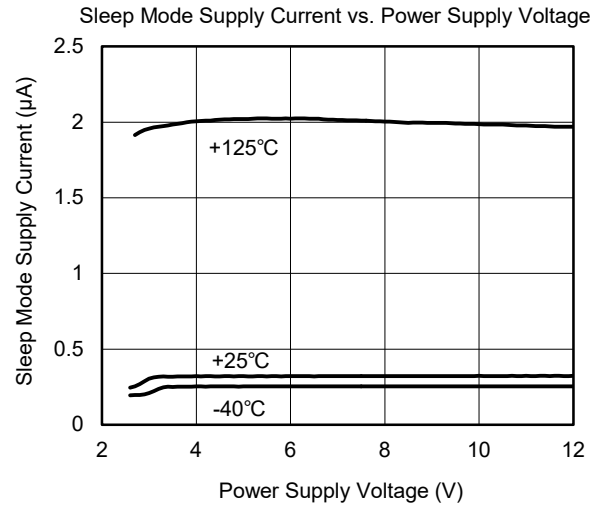
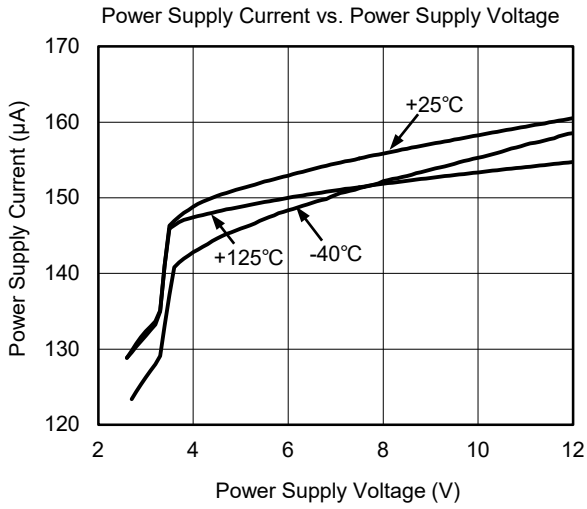

FUNCTIONAL BLOCK DIAGRAM

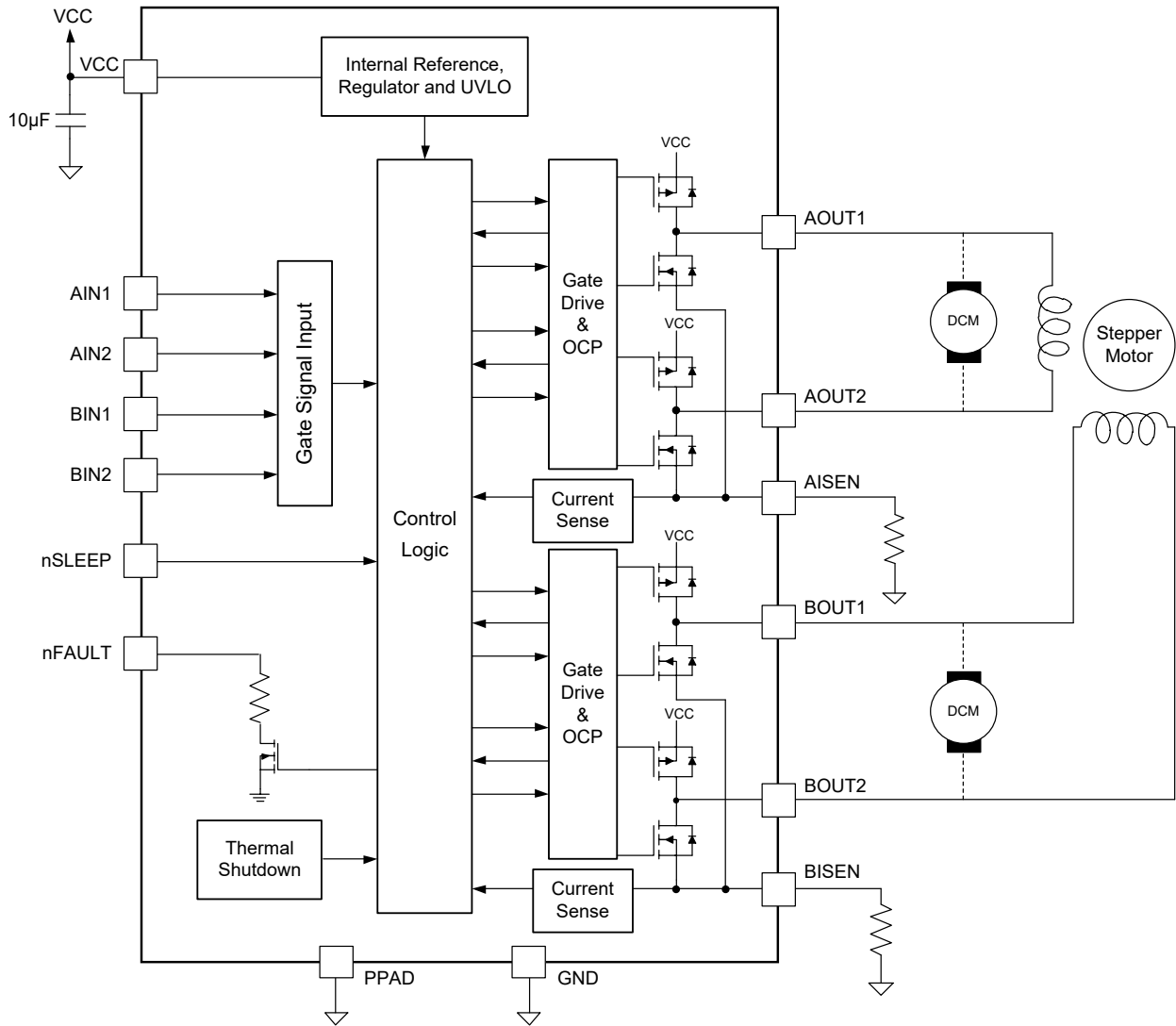

Figure 1. SGM42633 Block Diagram

DETAILED DESCRIPTION

The SGM42633 is a dual H-bridge motor driver with current regulation circuitry. Each output driver block consists of NMOS and PMOS configured as full H-bridges which can operate over a supply voltage range of 2.5V to 12V. The SGM42633 can provide output current up to 700mA.

The output current can be regulated by PWM from xIN1/xIN2 input or internal current limit.

Protection features include under-voltage lockout, over-current protection and thermal shutdown. It has low power sleep mode which is provided to save power dissipation.

PWM Motor Drivers

Please refer to the following motor control block diagram of SGM42633:

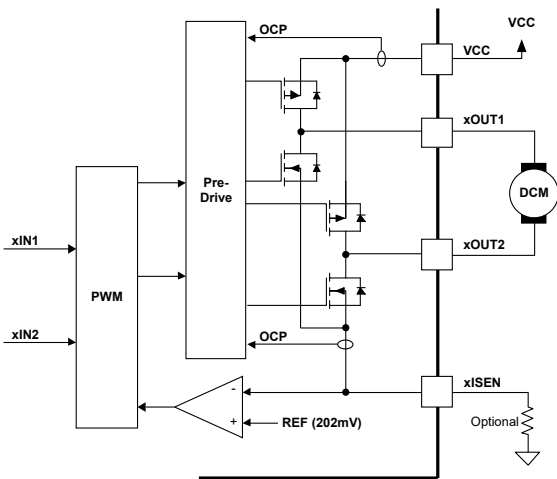

Figure 2. H-Bridge and Current Chopping Circuitry

Bridge Control and Decay Modes

Please refer to xIN1/xIN2 input logic in Table 1 below:

Table 1. H-Bridge Logic

xIN1	xIN2	xOUT1	xOUT2	Function
0	0	Z	Z	Coast/Fast Decay
0	1	L	H	Reverse
1	0	H	L	Forward
1	1	L	L	Brake/Slow Decay

The SGM42633 also supports PWM mode input to control the motor speed.

According to the PWM input signals on xIN1 and xIN2,

the device supports fast and slow decay modes, as shown in Table 2.

Table 2. PWM Control of Motor Speed

xIN1	xIN2	Function
PWM	0	Forward PWM, Fast Decay
1	PWM	Forward PWM, Slow Decay
0	PWM	Reverse PWM, Fast Decay
PWM	1	Reverse PWM, Slow Decay

If connecting a sense resistor from xISEN pin to GND, the internal current limit is always enabled. To disable this function, please short the xISEN pin to GND directly. Please refer to Figure 3 for the current path of the drive and the decay modes.

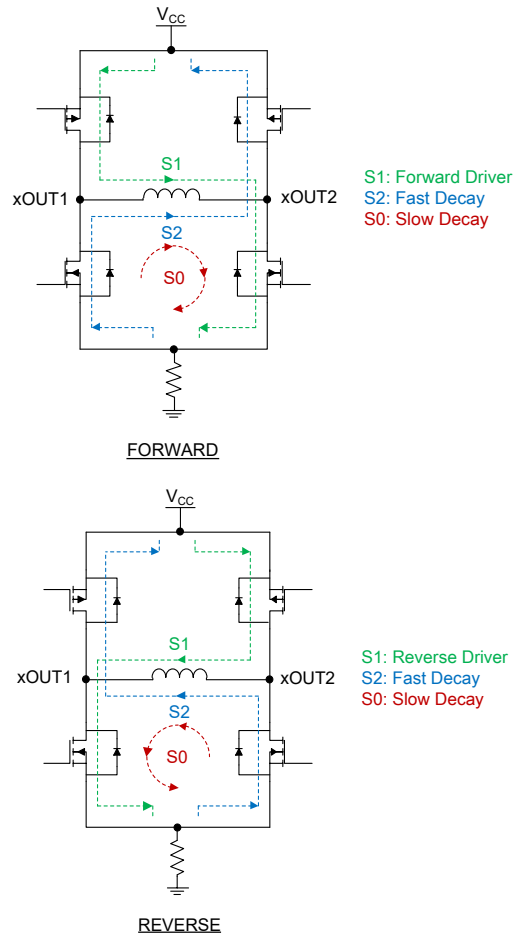

Figure 3. Drive and Decay Modes

DETAILED DESCRIPTION (continued)

Current Control

When the output is enabled, the motor current rises up depending on the power supply and motor inductance, and the xISEN pin voltage is ignored for a fixed blanking time of about 3.2µs. After that, if the xISEN voltage reaches the internal reference voltage (V_{TRIP}) of typically 202mV, the high-side MOSFETs may be turned off, and both low-side MOSFETs may be turned on for a fixed time of 25µs.

Please refer to the following calculation in Equation 1.

$$I_{CHOP} = \frac{202mV}{R_{xISEN}} \quad (1)$$

For example, if the sense resistor is 0.5Ω, then according to the calculation, the current limit point is about 404mA. To disable the current limit function, short the xISEN pin to GND directly.

Decay Mode

After any drive phase, when a phase current reaches the current limit setting point, the device may go to slow decay mode (two low-side MOSFETs on) for 25µs.

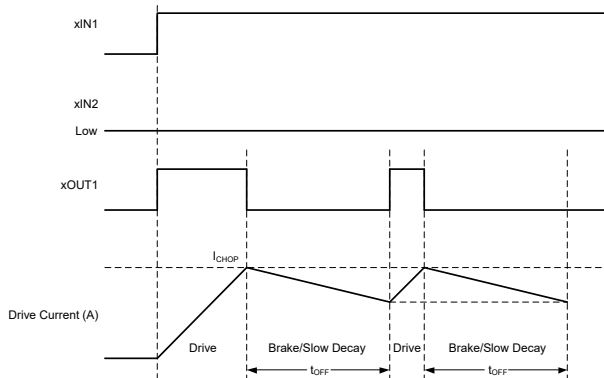

Figure 4. Current Chopping Operation

Sleep Mode

The nSLEEP is an active low input that puts the device into low power (sleep mode) state. In sleep mode, all bridges are disabled. All logic inputs are ignored. When waking up from sleep mode, time delay (t_{WAKE}) is needed before outputs operate.

Parallel Mode

The SGM42633 can be connected in parallel for higher current applications. Figure 5 shows this configuration.

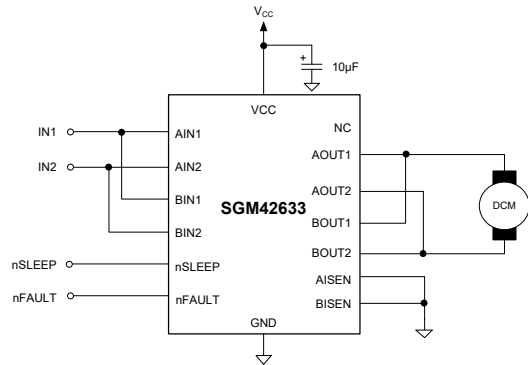

Figure 5. Parallel Mode Schematic

Protection Circuits

The SGM42633 integrates over-current, over-temperature and under-voltage protections.

Over-Current Protection (OCP)

Each MOSFET is protected by its own over-current protection circuit. In case of an over-current (any direction), the whole bridge will be disabled (shutdown) and the nFAULT pin will be driven low. The outputs may retry after OCP protection period (t_{OCP}). An over-current will occur due to a short between a switching node and ground or to the VCC supply line, or to the other node of the bridge (a winding short).

The OCP protection circuit works even if the xISEN pin is shorted to GND.

Thermal Shutdown (TSD)

All bridges and drivers are shutdown if a junction over-temperature occurs in the device and the nFAULT pin will be driven low. Once the temperature goes back to the safe level, the device resumes its operation.

Under-Voltage Lockout (UVLO)

If the voltages on VCC pin fall below their under-voltage lockout thresholds, the device will be disabled and internal logic will be reset. Device resumes operation when all of them go back above their UVLO thresholds. The UVLO event is not reported on the nFAULT pin.

DETAILED DESCRIPTION (continued)

Table 3. Device Protection

Fault	Condition	Error Report	H-Bridge	Internal Circuits	Recovery
V _{CC} Under-Voltage Lockout (UVLO)	V _{CC} < 2.1V	None	Disabled	Disabled	V _{CC} > 2.3V
Over-Current Protection (OCP)	I _{OUT} > I _{OCP}	nFAULT	Disabled	Operating	OCP
Thermal Shutdown (TSD)	T _J > T _{TSD}	nFAULT	Disabled	Operating	T _J < T _{TSD} - T _{HYS}

Table 4. Modes of Operation

Fault	Condition	H-Bridge	Internal Circuits
Operating	nSLEEP pin high	Operating	Operating
Sleep Mode	nSLEEP pin low	Disabled	Disabled
Fault Encountered	Any fault condition met	Disabled	See Table 3

APPLICATION INFORMATION

Power Supply Recommendations

The SGM42633's working voltage range is from 2.5V to 12V. It is recommended to connect at least one 10µF ceramic capacitor between VCC and GND, as close as possible to the VCC pin of the device.

Motor datasheets generally specify the capacitance value, however, it is recommended to do a system level test to size the bypass capacitors properly.

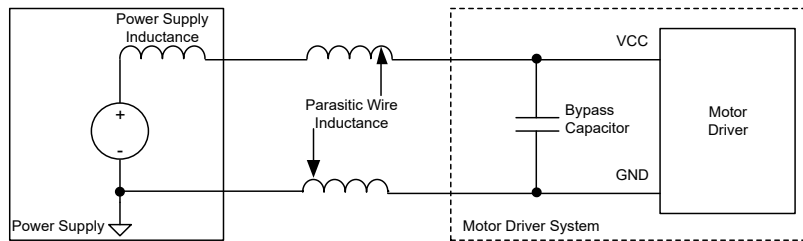

Figure 6. Setup of Motor Drive System with External Power Supply

REVISION HISTORY

NOTE: Page numbers for previous revisions may differ from page numbers in the current version.

AUGUST 2022 – REV.A.2 to REV.A.3	Page
Updated Detailed Description section	All
AUGUST 2021 – REV.A.1 to REV.A.2	Page
Updated Electrical Characteristics section	5
JULY 2021 – REV.A to REV.A.1	Page
Updated Electrical Characteristics section	4, 5
Changes from Original (DECEMBER 2019) to REV.A	Page
Changed from product preview to production data	All

PACKAGE OUTLINE DIMENSIONS

TSSOP-16 (Exposed Pad)

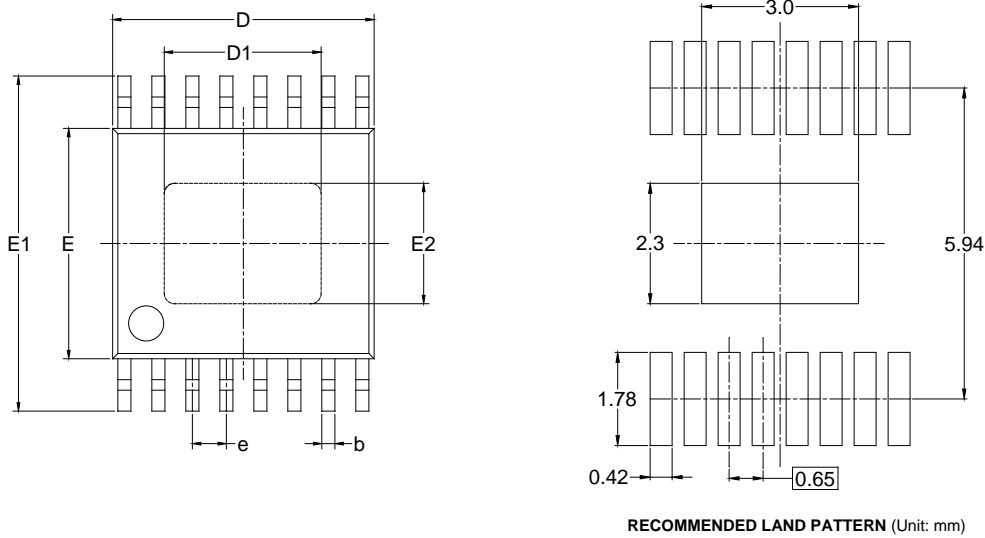

RECOMMENDED LAND PATTERN (Unit: mm)

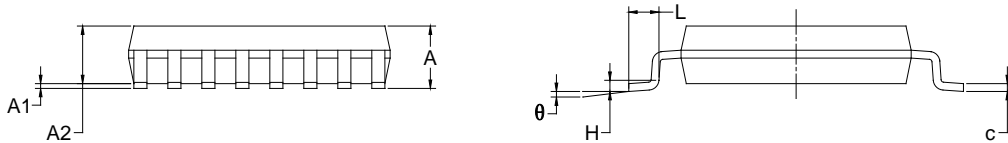

Symbol	Dimensions In Millimeters		Dimensions In Inches	
	MIN	MAX	MIN	MAX
A		1.100		0.043
A1	0.050	0.150	0.002	0.006
A2	0.800	1.000	0.031	0.039
b	0.190	0.300	0.007	0.012
c	0.090	0.200	0.004	0.008
D	4.900	5.100	0.193	0.201
D1	2.900	3.100	0.114	0.122
E	4.300	4.500	0.169	0.177
E1	6.250	6.550	0.246	0.258
E2	2.200	2.400	0.087	0.094
e	0.650 BSC		0.026 BSC	
L	0.500	0.700	0.02	0.028
H	0.25 TYP		0.01 TYP	
θ	1°	7°	1°	7°

NOTES:

1. Body dimensions do not include mode flash or protrusion.
2. This drawing is subject to change without notice.

PACKAGE INFORMATION

PACKAGE OUTLINE DIMENSIONS

TQFN-3x3-16L

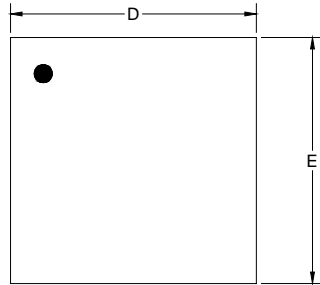

TOP VIEW

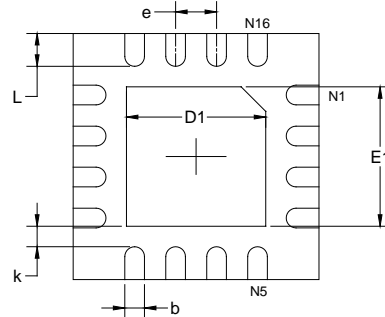

BOTTOM VIEW

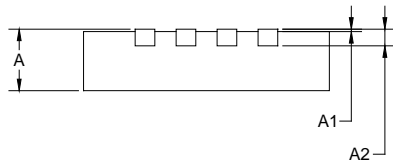

SIDE VIEW

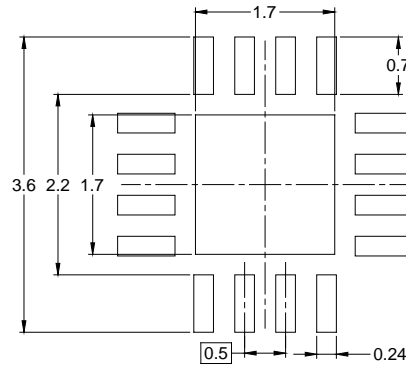

RECOMMENDED LAND PATTERN (Unit: mm)

Symbol	Dimensions In Millimeters		Dimensions In Inches	
	MIN	MAX	MIN	MAX
A	0.700	0.800	0.028	0.031
A1	0.000	0.050	0.000	0.002
A2	0.203 REF		0.008 REF	
D	2.900	3.100	0.114	0.122
D1	1.600	1.800	0.063	0.071
E	2.900	3.100	0.114	0.122
E1	1.600	1.800	0.063	0.071
k	0.200 MIN		0.008 MIN	
b	0.180	0.300	0.007	0.012
e	0.500 TYP		0.020 TYP	
L	0.300	0.500	0.012	0.020

NOTE: This drawing is subject to change without notice.

TAPE AND REEL INFORMATION

REEL DIMENSIONS



TAPE DIMENSIONS

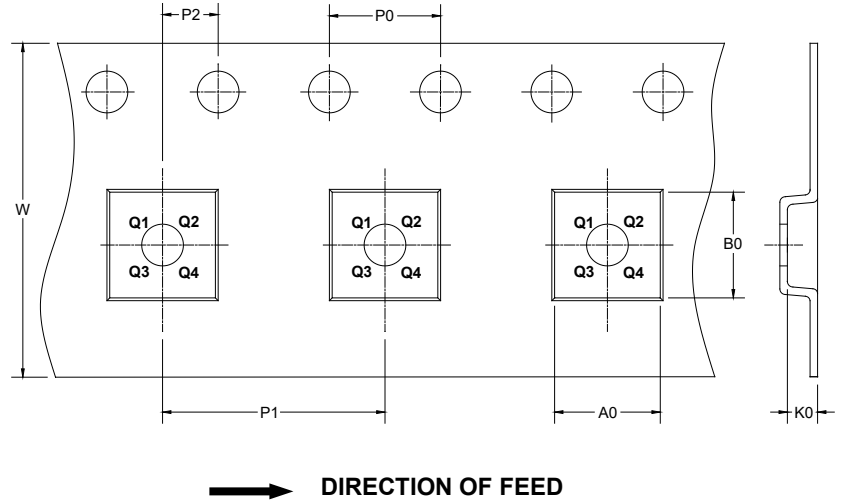

NOTE: The picture is only for reference. Please make the object as the standard.

KEY PARAMETER LIST OF TAPE AND REEL

Package Type	Reel Diameter	Reel Width W1 (mm)	A0 (mm)	B0 (mm)	K0 (mm)	P0 (mm)	P1 (mm)	P2 (mm)	W (mm)	Pin1 Quadrant
TSSOP-16 (Exposed Pad)	13"	12.4	6.90	5.60	1.50	4.0	8.0	2.0	12.0	Q1
TQFN-3×3-16L	13"	12.4	3.35	3.35	1.13	4.0	8.0	2.0	12.0	Q2

000001

PACKAGE INFORMATION

CARTON BOX DIMENSIONS



NOTE: The picture is only for reference. Please make the object as the standard.

KEY PARAMETER LIST OF CARTON BOX

Reel Type	Length (mm)	Width (mm)	Height (mm)	Pizza/Carton
13"	386	280	370	5

DD0002

单击下面可查看定价，库存，交付和生命周期等信息

[>>SGMICRO\(圣邦微电子\)](#)