



SGM2578

Ultra Small, Low Input Voltage, Low R_{ON} Load Switch

GENERAL DESCRIPTION

The SGM2578 is a single channel power distribution switch. The switch operates from a wide range of 1V to 5V supply voltage, and is controlled by the EN pin. It can be used in USB power distribution applications.

A 54m Ω low R_{ON} N-MOSFET is integrated. The small size and quiescent current make the device very suitable for space limited, battery-powered applications.

A number of protection features are provided in the device including soft-start, current limit and thermal shutdown. The internal reverse-voltage function will protect devices on the input side of the switch. The SGM2578 has automatic discharge function to quickly discharge V_{OUT} in the disabled status.

The SGM2578 is available in a Green WLCSP-0.9 \times 0.9-4B package and operates over a temperature range of -40 $^{\circ}$ C to +85 $^{\circ}$ C.

FEATURES

- **Low Input Voltage: 1V to 5V**
- **Low On-Resistance (R_{ON})**
 - $R_{ON} = 54m\Omega$ at $V_{IN} = 5.0V$
 - $R_{ON} = 54m\Omega$ at $V_{IN} = 3.6V$
 - $R_{ON} = 58m\Omega$ at $V_{IN} = 2.5V$
 - $R_{ON} = 74m\Omega$ at $V_{IN} = 1.8V$
 - $R_{ON} = 84m\Omega$ at $V_{IN} = 1.2V$
 - $R_{ON} = 84m\Omega$ at $V_{IN} = 1.0V$
- **Continuous Switch Current: 1A (MAX)**
- **Quiescent Current: 5 μ A (TYP)**
- **Shutdown Current: < 1.5 μ A**
- **Quick Output Discharge (QOD)**
- **Soft-Start Function**
- **Evaluated to IEC 60950-1, Ed 2, Am1, Annex CC, Test Program 1 with CB Report**
- **Available in a Green WLCSP-0.9 \times 0.9-4B Package**

APPLICATIONS

Portable Medical Equipment
Battery Powered Equipment
Hot-Plug Power Supply
Motherboard USB Power Switch
Portable Media Players

PACKAGE/ORDERING INFORMATION

MODEL	PACKAGE DESCRIPTION	SPECIFIED TEMPERATURE RANGE	ORDERING NUMBER	PACKAGE MARKING	PACKING OPTION
SGM2578	WLCSP-0.9×0.9-4B	-40°C to +85°C	SGM2578YG/TR	K2 XX	Tape and Reel, 3000

MARKING INFORMATION

NOTE: XX = Date Code.

YY — Serial Number

XX

Green (RoHS & HSF): SG Micro Corp defines "Green" to mean Pb-Free (RoHS compatible) and free of halogen substances. If you have additional comments or questions, please contact your SGMICRO representative directly.

ABSOLUTE MAXIMUM RATINGS

Input Voltage Range, V _{IN}	-0.3V to +5.5V
Output Voltage Range, V _{OUT}	-0.3V to (V _{IN} + 0.3V)
EN Voltage Range, V _{EN}	-0.3V to +5.5V
Maximum Continuous Switch Current, I _{MAX}	
V _{IN} ≥ 1.2V	1000mA
V _{IN} = 1.0V	600mA
Package Thermal Resistance	
WLCSP-0.9×0.9-4B, θ _{JA}	188°C/W
Junction Temperature	+150°C
Storage Temperature Range	-65°C to +150°C
Lead Temperature (Soldering, 10s)	+260°C
ESD Susceptibility	
HBM	2000V
MM	300V

RECOMMENDED OPERATING CONDITIONS

Operating Temperature Range	-40°C to +85°C
Input Voltage Range, V _{IN}	1V to 5V
EN Voltage Range, V _{EN}	0V to 5V
Output Voltage Range, V _{OUT}	0V to V _{IN}

OVERSTRESS CAUTION

Stresses beyond those listed in Absolute Maximum Ratings may cause permanent damage to the device. Exposure to absolute maximum rating conditions for extended periods may affect reliability. Functional operation of the device at any conditions beyond those indicated in the Recommended Operating Conditions section is not implied.

ESD SENSITIVITY CAUTION

This integrated circuit can be damaged if ESD protections are not considered carefully. SGMICRO recommends that all integrated circuits be handled with appropriate precautions. Failure to observe proper handling and installation procedures can cause damage. ESD damage can range from subtle performance degradation to complete device failure. Precision integrated circuits may be more susceptible to damage because even small parametric changes could cause the device not to meet the published specifications.

DISCLAIMER

SG Micro Corp reserves the right to make any change in circuit design, or specifications without prior notice.

PIN CONFIGURATION

(TOP VIEW)

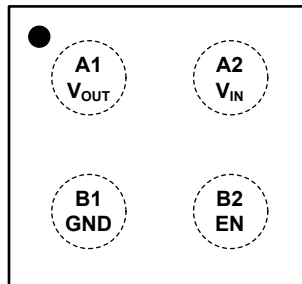

WLCSP-0.9×0.9-4B

PIN DESCRIPTION

PIN	NAME	FUNCTION
A1	V _{OUT}	Switch Output.
A2	V _{IN}	Switch Input and Power Supply. A ceramic capacitor needs to be added between V _{IN} pin and GND.
B1	GND	Ground.
B2	EN	Chip Enable Pin. Logic high to enable the device. The pull-down resistor of EN pin is about 560kΩ.

ELECTRICAL CHARACTERISTICS(Full = -40°C to +85°C, V_{IN} = 3.6V, unless otherwise noted.)

PARAMETER	SYMBOL	CONDITIONS	TEMP	MIN	TYP	MAX	UNITS
Power Supplies and Currents							
Quiescent Current	I _{IN}	I _{OUT} = 0, V _{IN} = V _{EN}	Full		5	12	μA
Off-State Supply Current	I _{IN(OFF)}	V _{EN} = GND, V _{OUT} = Open	Full		0.01	1.5	μA
Off-State Supply Current	I _{IN(LEAK)}	V _{EN} = GND, V _{OUT} = 0V	Full		0.01	1	μA
EN Pin Pull-Down Resistor	R _{PULL-DOWN}		+25°C	360	560	800	kΩ
Resistance and Switch Characteristics							
On-State Resistance	R _{ON}	I _{OUT} = 200mA	V _{IN} = 5.0V	+25°C		54	mΩ
			V _{IN} = 3.6V	+25°C		54	
			V _{IN} = 2.5V	+25°C		58	
			V _{IN} = 1.8V	+25°C		74	
			V _{IN} = 1.2V	+25°C		84	
			V _{IN} = 1.0V	+25°C		84	
Output Pull-Down Resistance	R _{PD}	V _{IN} = 3.3V, V _{EN} = GND, I _{OUT} = 30mA	+25°C		50		Ω
EN							
Enable Input Logic High Voltage	V _{IH}	V _{IN} = 1V to 5V	+25°C	1.6			V
Enable Input Logic Low Voltage	V _{IL}		+25°C	0		0.4	V
Switching Characteristics							
Turn-On Time	t _{ON}	V _{IN} = 3.6V, R _L = 10Ω, C _L = 0.1μF	+25°C		680		μs
Turn-Off Time	t _{OFF}		+25°C		3.4		
V _{OUT} Rise Time	t _R		+25°C		590		
V _{OUT} Fall Time	t _F		+25°C		2.6		
Turn-On Time	t _{ON}	V _{IN} = 1.0V, R _L = 10Ω, C _L = 0.1μF	+25°C		695		μs
Turn-Off Time	t _{OFF}		+25°C		34		
V _{OUT} Rise Time	t _R		+25°C		435		
V _{OUT} Fall Time	t _F		+25°C		14		

TYPICAL PERFORMANCE CHARACTERISTICS

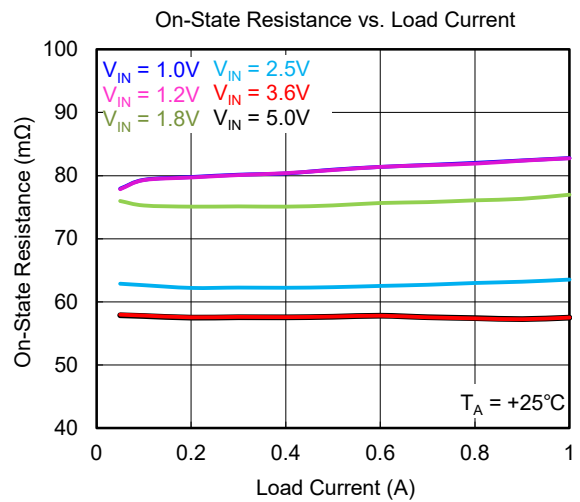
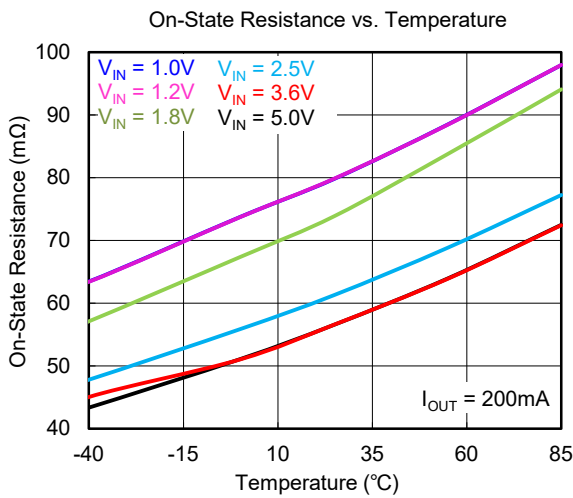
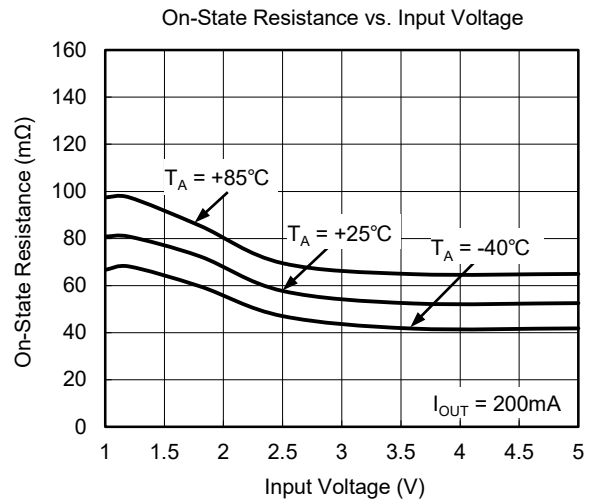
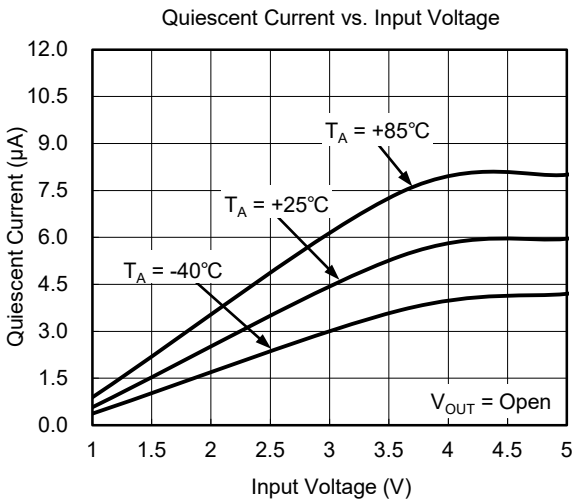
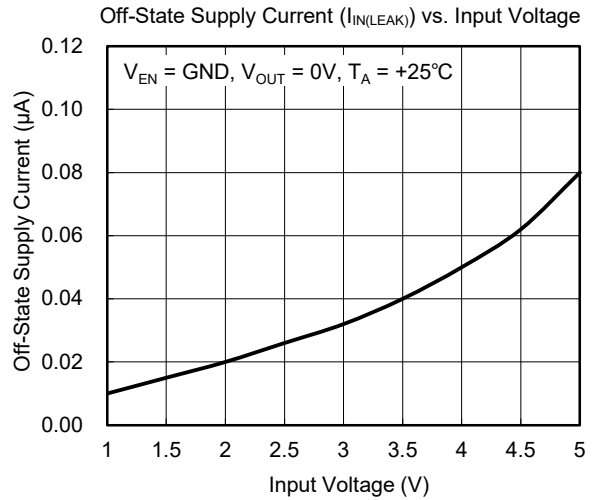
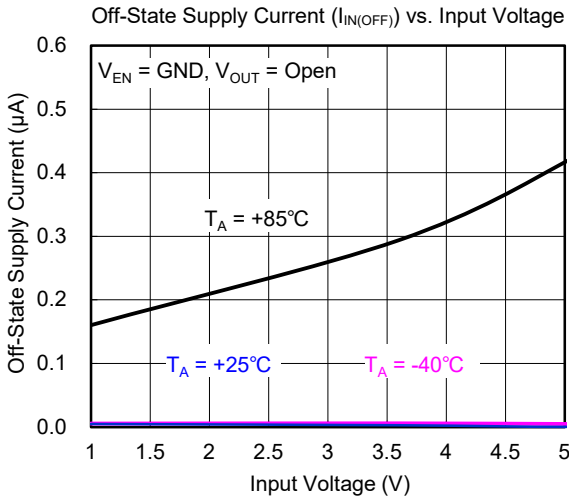

TYPICAL PERFORMANCE CHARACTERISTICS (continued)

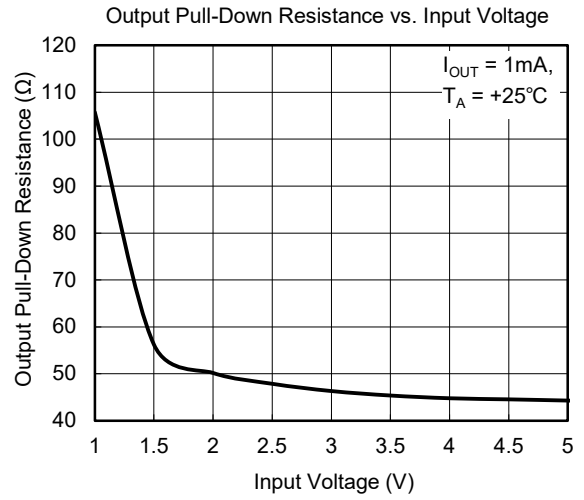
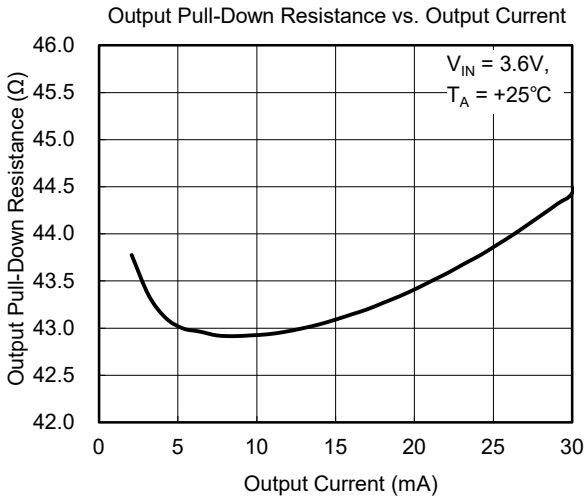

Output Voltage vs. EN Voltage Threshold (EN Pin Voltage Decreasing)

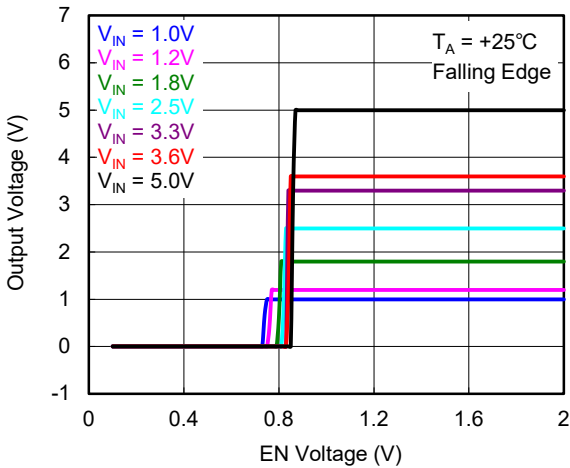

Output Voltage vs. EN Voltage Threshold (EN Pin Voltage Increasing)

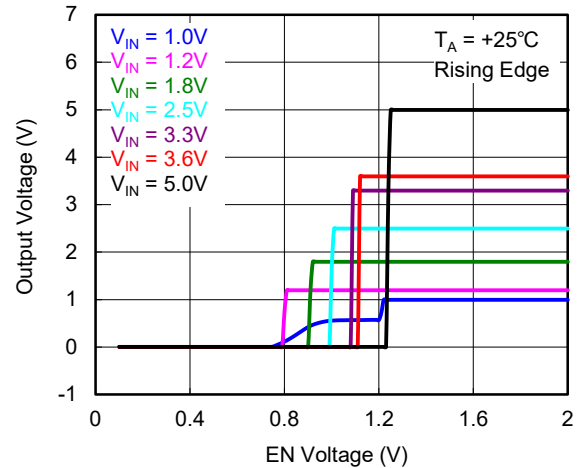

Rise Time vs. Input Voltage ($C_L = 0.1\mu F$)

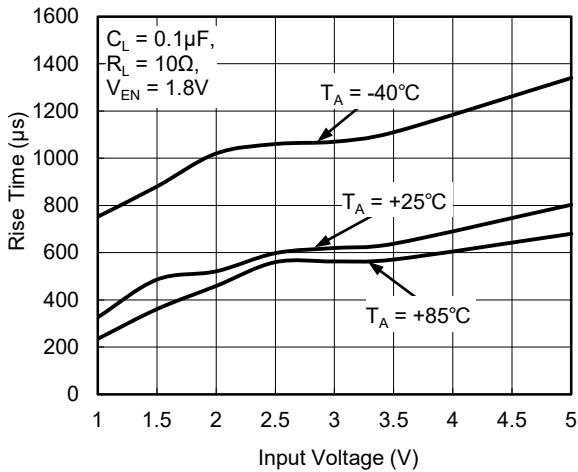

Rise Time vs. Input Voltage ($C_L = 1\mu F$)

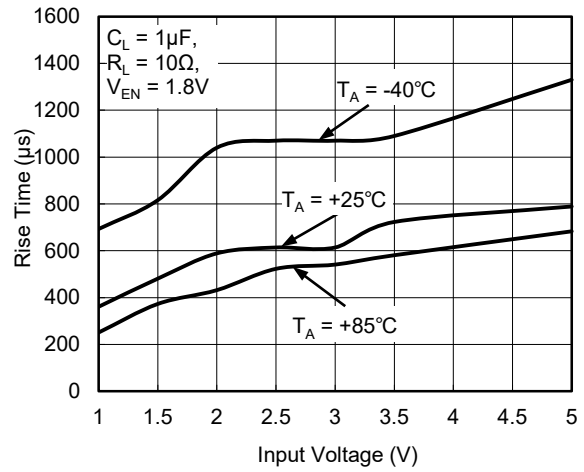

TYPICAL PERFORMANCE CHARACTERISTICS (continued)

Rise Time vs. Temperature

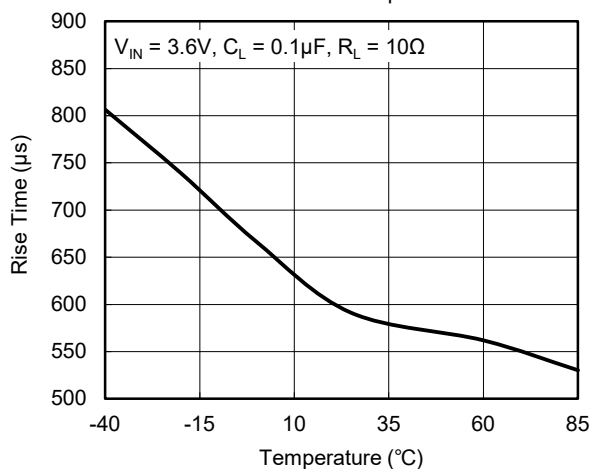

Rise Time vs. Temperature

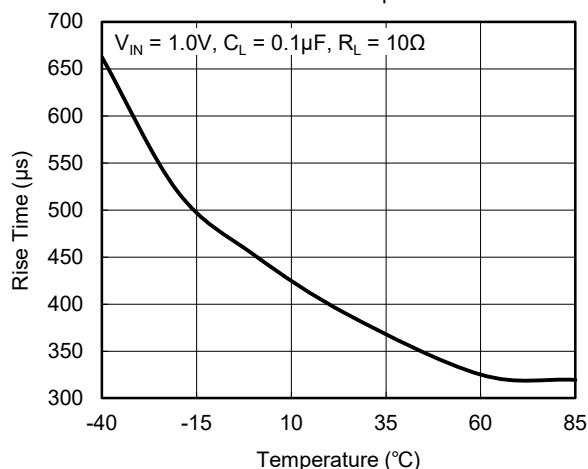

Fall Time vs. Temperature

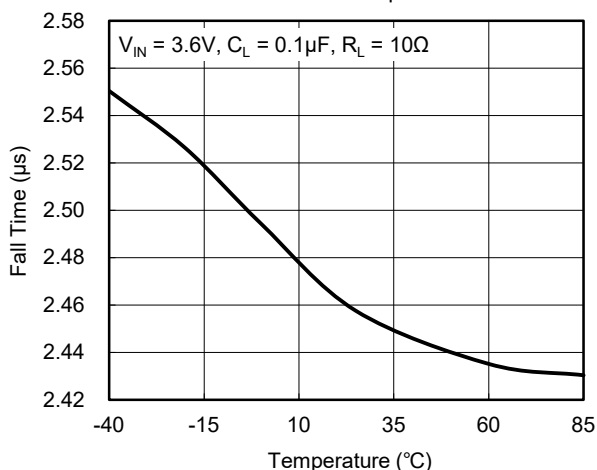

Fall Time vs. Temperature

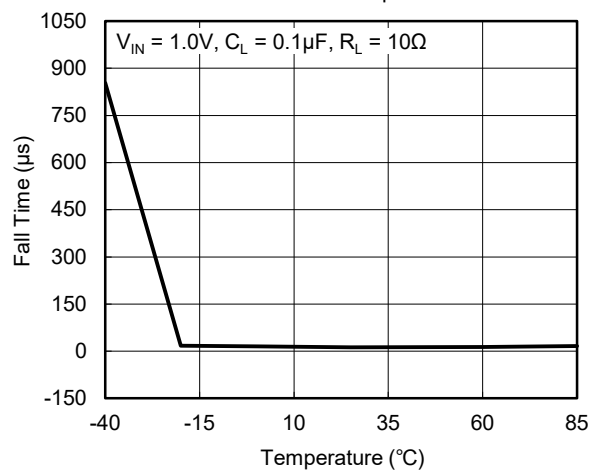

Turn-On Time vs. Temperature

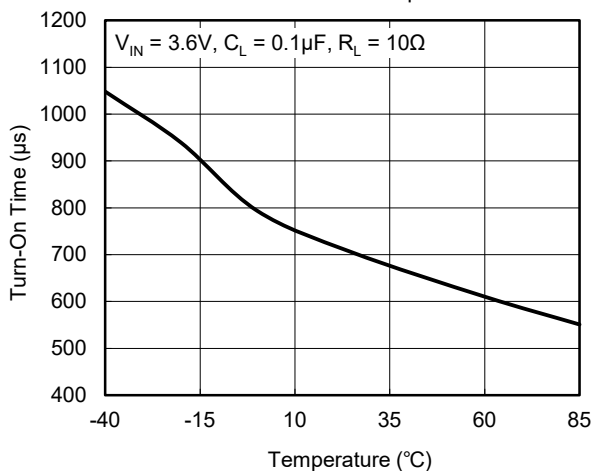

Turn-On Time vs. Temperature

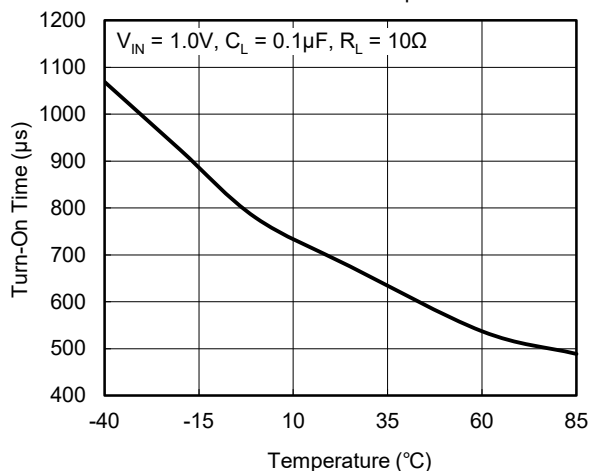

TYPICAL PERFORMANCE CHARACTERISTICS (continued)

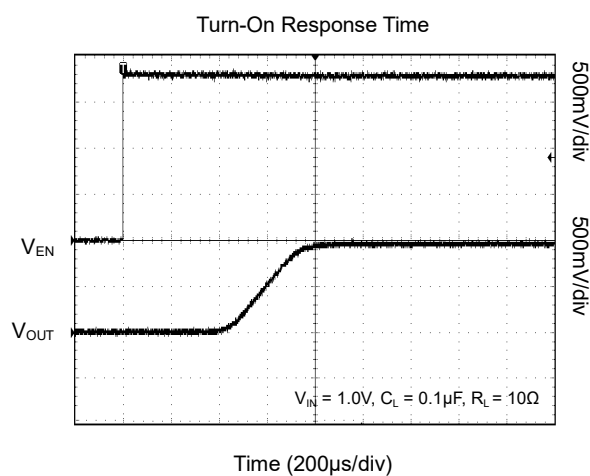
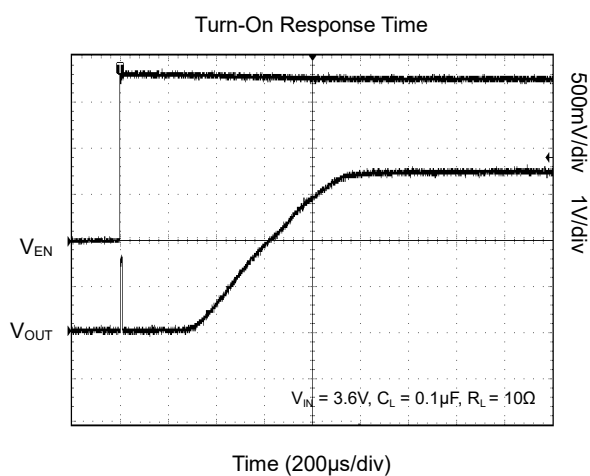
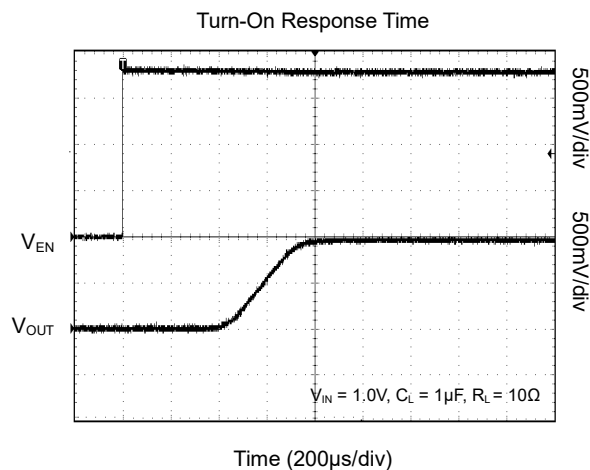
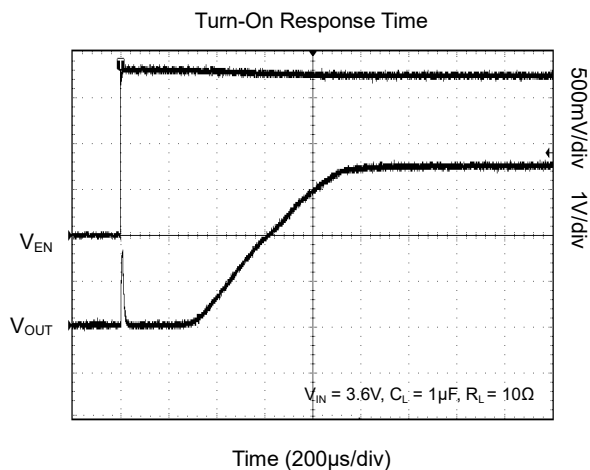
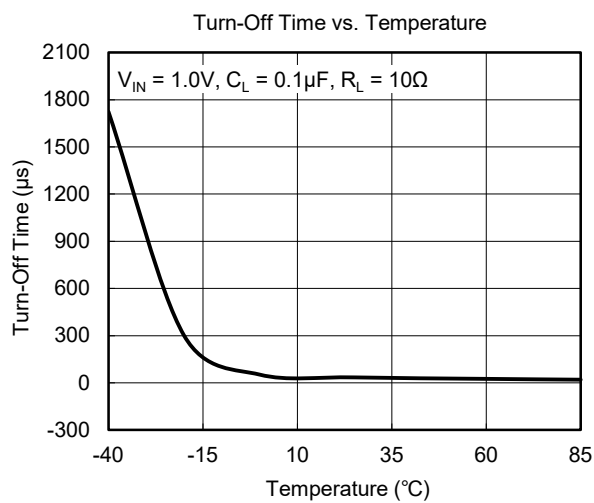
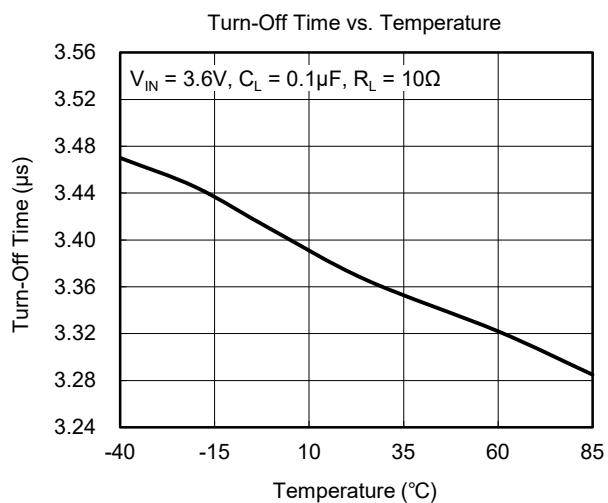

TYPICAL PERFORMANCE CHARACTERISTICS (continued)

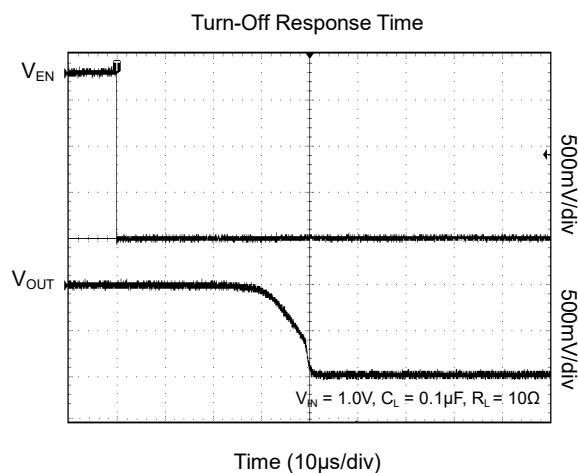
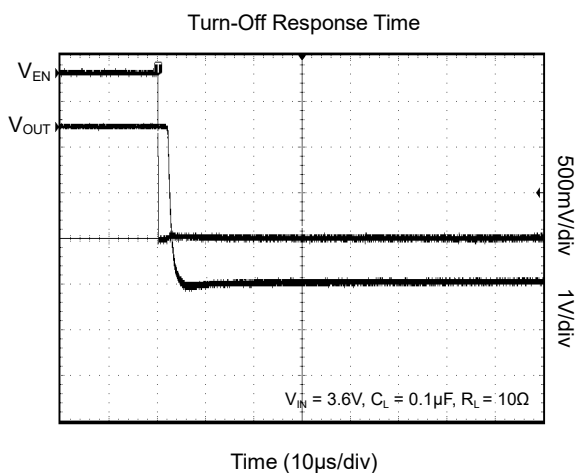
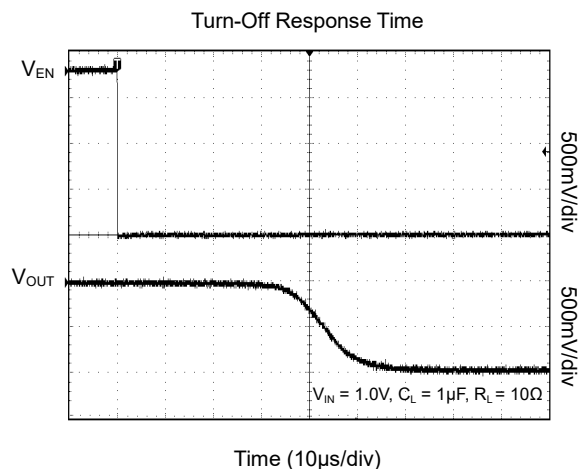
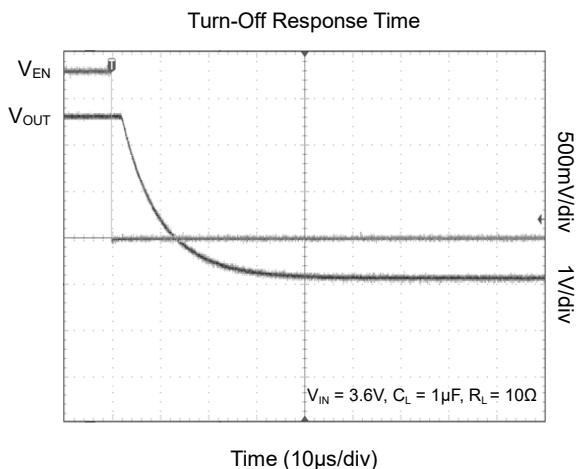

FUNCTIONAL BLOCK DIAGRAM

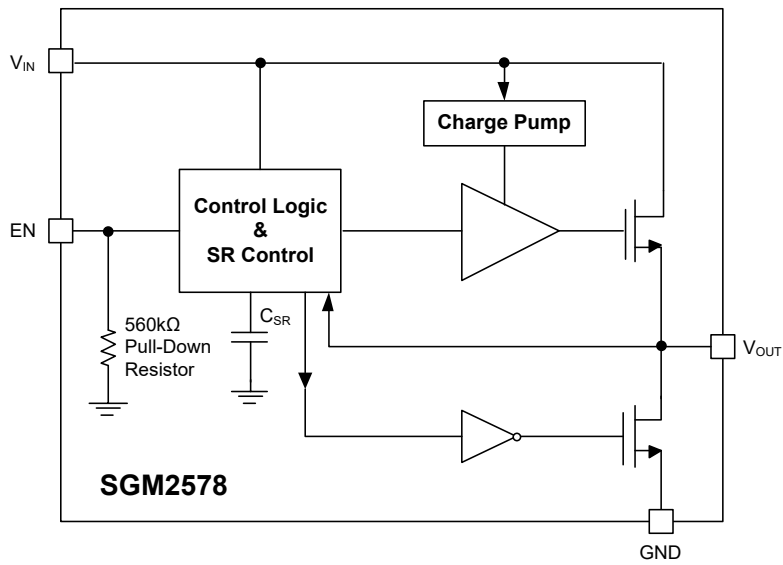

Figure 1. Block Diagram

REVISION HISTORY

NOTE: Page numbers for previous revisions may differ from page numbers in the current version.

	Page
MAY 2019 – REV.A.4 to REV.B	
Updated Package/Ordering Information section.....	2
AUGUST 2018 – REV.A.3 to REV.A.4	
Updated Typical Performance Characteristics section	9
MARCH 2018 – REV.A.2 to REV.A.3	
Updated Feature section	1
Update Typical Performance Characteristics section	5
MAY 2017 – REV.A.1 to REV.A.2	
Updated Packing Option.....	2
JUNE 2014 – REV.A to REV.A.1	
Changed the package.....	13
Changes from Original (MAY 2014) to REV.A	
Changed from product preview to production data.....	All

PACKAGE OUTLINE DIMENSIONS

WLCSP-0.9×0.9-4B

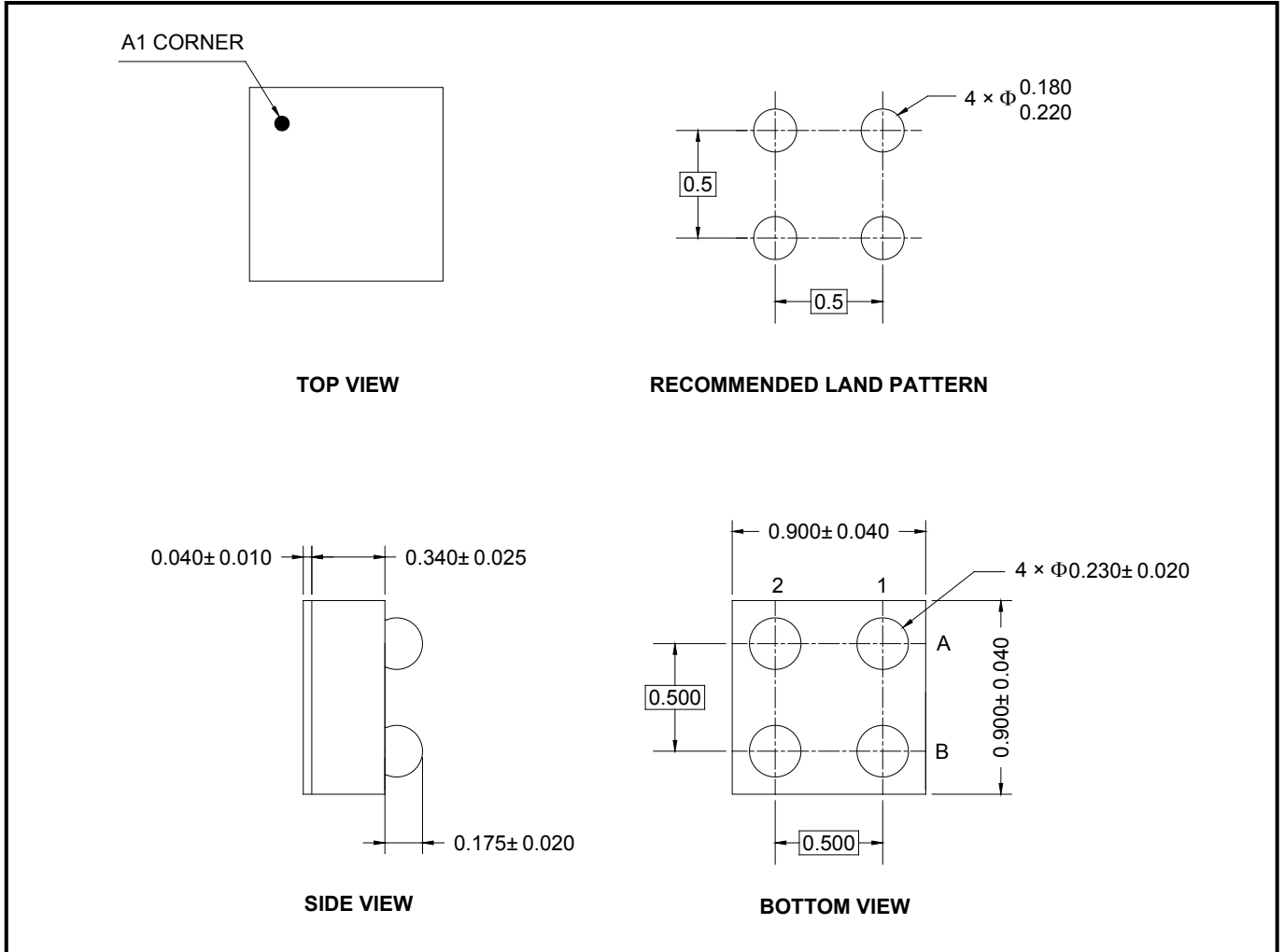

NOTE: All linear dimensions are in millimeters.

PACKAGE INFORMATION

TAPE AND REEL INFORMATION

REEL DIMENSIONS



TAPE DIMENSIONS



NOTE: The picture is only for reference. Please make the object as the standard.

KEY PARAMETER LIST OF TAPE AND REEL

Package Type	Reel Diameter	Reel Width W1 (mm)	A0 (mm)	B0 (mm)	K0 (mm)	P0 (mm)	P1 (mm)	P2 (mm)	W (mm)	Pin1 Quadrant
WLCSP-0.9×0.9-4B	7"	9.2	1.00	1.00	0.70	4.0	4.0	2.0	8.0	Q1

000001

PACKAGE INFORMATION

CARTON BOX DIMENSIONS



NOTE: The picture is only for reference. Please make the object as the standard.

KEY PARAMETER LIST OF CARTON BOX

Reel Type	Length (mm)	Width (mm)	Height (mm)	Pizza/Carton
7" (Option)	368	227	224	8
7"	442	410	224	18

DD0002

单击下面可查看定价，库存，交付和生命周期等信息

[>>SGMICRO\(圣邦微电子\)](#)