



# SGM4863

## Dual 2.1W Audio Power Amplifier Plus Stereo Headphone Function

### GENERAL DESCRIPTION

The SGM4863 is a dual bridge-connected audio power amplifier which operates from 2.8V to 5.5V supply voltage. It can deliver 2.5W into a 3Ω load or 2.1W into a 4Ω load from 5V supply at THD+N = 1%. It is designed for portable applications. When driving stereo headphones, the amplifiers can operate in single-ended mode at the headphone input pin.

The SGM4863 integrates dual bridge speaker amplifier and stereo headphone amplifier on one chip to simplify design.

The SGM4863 has pop/click suppression circuitry, low power consumption shutdown mode and thermal shutdown protection.

The SGM4863 is available in Green TSSOP-20 (Exposed Pad), TQFN-3×3-20L, TSSOP-16 (Exposed Pad), SOIC-16 and DIP-16 packages. It operates over an ambient temperature range of -40°C to +85°C.

### FEATURES

- **Supply Voltage Range: 2.8V to 5.5V**
- **2.5W into 3Ω Load from 5V Power Supply at THD+N = 1% (Typical, per Channel)**
- **2.1W into 4Ω Load from 5V Power Supply at THD+N = 1% (Typical, per Channel)**
- **1.3W into 8Ω Load from 5V Power Supply at THD+N = 1% (Typical, per Channel)**
- **Shutdown Current: 0.03μA (TYP)**
- **Stereo Headphone Amplifier Mode**
- **Pop/Click Suppression Circuitry**
- **Unity-Gain Stable**
- **Thermal Shutdown Protection**
- **-40°C to +85°C Operating Temperature Range**
- **Available in Green TSSOP-20 (Exposed Pad), TQFN-3×3-20L, TSSOP-16 (Exposed Pad), SOIC-16 and DIP-16 Packages**

### APPLICATIONS

TVs  
Multimedia Monitors  
Portable and Desktop Computers

**PACKAGE/ORDERING INFORMATION**

MODEL	PACKAGE DESCRIPTION	SPECIFIED TEMPERATURE RANGE	ORDERING NUMBER	PACKAGE MARKING	PACKING OPTION
SGM4863	TSSOP-20 (Exposed Pad)	-40°C to +85°C	SGM4863YPTS20G/TR	SGM4863YPTS20 XXXXX	Tape and Reel, 3000
	TQFN-3x3-20L	-40°C to +85°C	SGM4863YTQG20G/TR	SGM4863QG XXXXX	Tape and Reel, 3000
	TSSOP-16 (Exposed Pad)	-40°C to +85°C	SGM4863YPTS16/TR	SGM4863YPTS16 XXXXX	Tape and Reel, 3000
	SOIC-16	-40°C to +85°C	SGM4863YS16/TR	SGM4863YS16 XXXXX	Tape and Reel, 2500
	DIP-16	-40°C to +85°C	SGM4863YP16	SGM4863YP16 XXXXX	20 Tube (500pcs)

**MARKING INFORMATION**

NOTE: XXXXX = Date Code and Vendor Code.

**XXXXX**

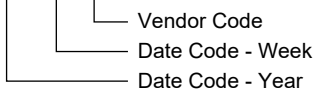

Green (RoHS & HSF): SG Micro Corp defines "Green" to mean Pb-Free (RoHS compatible) and free of halogen substances. If you have additional comments or questions, please contact your SGMICRO representative directly.

**ABSOLUTE MAXIMUM RATINGS**

- Supply Voltage.....6V
- Input Voltage..... -0.3V to (V<sub>CC</sub>) + 0.3V
- Storage Temperature Range .....-65°C to +150°C
- Junction Temperature.....+150°C
- Lead Temperature Range (Soldering, 10s).....+260°C
- ESD Susceptibility
- HBM.....4000V
- MM.....400V

**RECOMMENDED OPERATING CONDITIONS**

- Supply Voltage Range .....2.8V to 5.5V
- Operating Temperature Range .....-40°C to +85°C

**OVERSTRESS CAUTION**

Stresses beyond those listed in Absolute Maximum Ratings may cause permanent damage to the device. Exposure to absolute maximum rating conditions for extended periods may affect reliability. Functional operation of the device at any conditions beyond those indicated in the Recommended Operating Conditions section is not implied.

**ESD SENSITIVITY CAUTION**

This integrated circuit can be damaged if ESD protections are not considered carefully. SGMICRO recommends that all integrated circuits be handled with appropriate precautions. Failure to observe proper handling and installation procedures can cause damage. ESD damage can range from subtle performance degradation to complete device failure. Precision integrated circuits may be more susceptible to damage because even small parametric changes could cause the device not to meet the published specifications.

**DISCLAIMER**

SG Micro Corp reserves the right to make any change in circuit design, or specifications without prior notice.

PIN CONFIGURATIONS

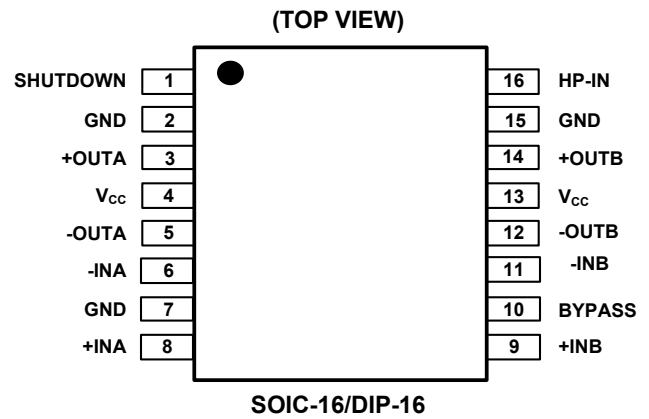
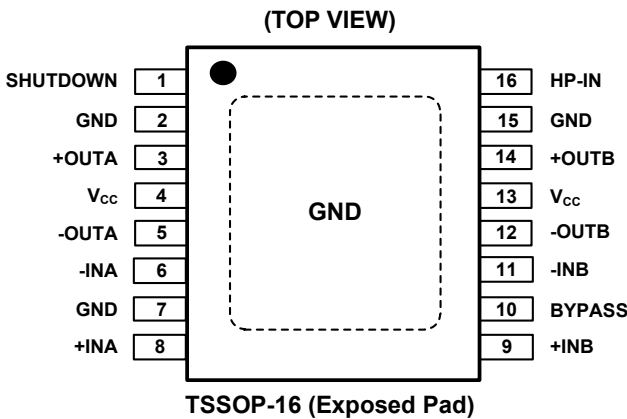
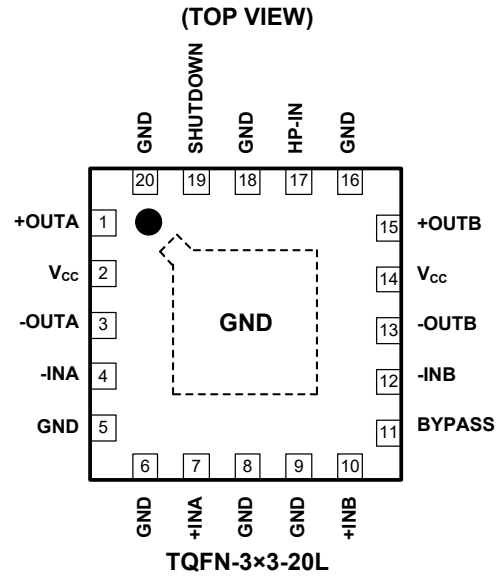
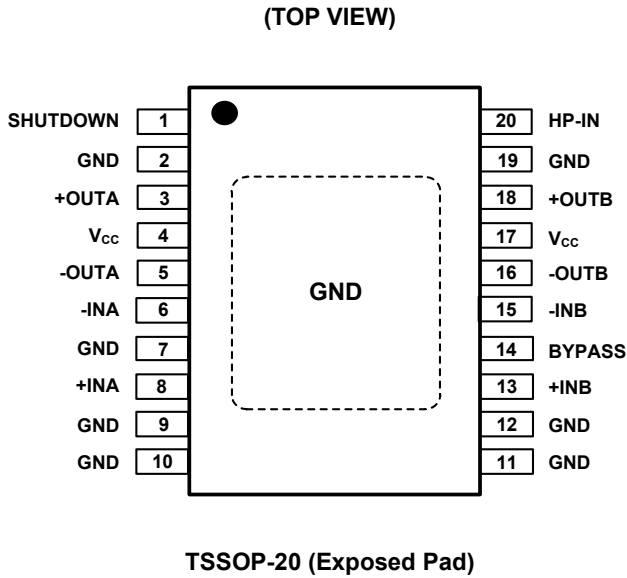

LOGIC LEVEL TRUTH TABLE

Shutdown	HP-in Pin	Operational Mode
Low	Logic Low	Bridged Amplifiers
Low	Logic High	Single-Ended Amplifiers
High	Logic Low	Micro-Power Shutdown
High	Logic High	Micro-Power Shutdown

## ELECTRICAL CHARACTERISTICS

(The following specifications apply for  $V_{CC} = 5V$ , limits apply for  $T_A = +25^\circ C$ , unless otherwise noted.)

PARAMETER	SYMBOL	CONDITIONS	MIN	TYP	MAX	UNITS
Supply Voltage	$V_{CC}$		2.8		5.5	V
Quiescent Power Supply Current	$I_Q$	$V_{IN} = 0V, I_O = 0A^{(1)}$ , BTL mode		5.7	10	mA
		$V_{IN} = 0V, I_O = 0A^{(1)}$ , SE mode		3.1	5	
Shutdown Current	$I_{SD}$	$V_{CC}$ applied to the SHUTDOWN pin		0.03	2	$\mu A$
Headphone Sense High Input Voltage	$V_{IH}$	Hold High for SE mode	4			V
Headphone Sense Low Input Voltage	$V_{IL}$	Hold Low for BTL mode			3.2	V
Shutdown Voltage Input High	$V_{SDIH}$		1.6			V
Shutdown Voltage Input Low	$V_{SDIL}$				0.5	V
Turn-On Time	$T_{ON}$	$C_{BYPASS} = 1\mu F$		480		ms
<b>Bridged-Mode Operation</b>						
Output Offset Voltage	$V_{OS}$	$V_{IN} = 0V$		9	30	mV
Output Power <sup>(2)</sup>	$P_O$	THD+N = 1%, f = 1kHz	$R_L = 3\Omega$		2.5	W
			$R_L = 4\Omega$		2.1	
			$R_L = 8\Omega$		1.3	
		THD+N = 10%, f = 1kHz	$R_L = 3\Omega$		3.2	
			$R_L = 4\Omega$		2.6	
			$R_L = 8\Omega$		1.6	
Total Harmonic Distortion + Noise	THD+N	f = 1kHz, $A_{VD} = 2$	$R_L = 4\Omega, P_O = 2W$		0.04	%
			$R_L = 8\Omega, P_O = 1W$		0.03	
Power Supply Rejection Ratio	PSRR	$V_{RIPPLE} = 200mV_{RMS}$ , $R_L = 8\Omega, C_{BYPASS} = 1.0\mu F$	f = 1kHz		-71	dB
			f = 217Hz		-73	
Crosstalk	$X_{TALK}$	f = 1kHz, $C_{BYPASS} = 1.0\mu F$			-86	dB
Signal to Noise Ratio	SNR	$V_{CC} = 5V, P_O = 1.1W, R_L = 8\Omega, BW < 80kHz$			-99	dB
<b>Single-Mode Operation</b>						
Output Offset Voltage	$V_{OS}$	$V_{IN} = 0V$		5	30	mV
Output Power	$P_O$	THD+N = 1%, f = 1kHz, $R_L = 8\Omega$			340	mW
					440	
					190	
					230	
					90	
					120	
Total Harmonic Distortion + Noise	THD+N	$A_V = -1, P_O = 75mW, 20Hz \leq f \leq 20kHz$ , $R_L = 32\Omega$			0.1	%
Power Supply Rejection Ratio	PSRR	$V_{RIPPLE} = 200mV_{RMS}$ , $C_{BYPASS} = 1.0\mu F$	f = 1kHz		-78	dB
			f = 217Hz		-74	
Crosstalk	$X_{TALK}$	f = 1kHz, $C_{BYPASS} = 1.0\mu F$			-81	dB
Signal to Noise Ratio	SNR	$P_O = 340mW, R_L = 8\Omega, BW < 80kHz$			-100	dB

## NOTES:

- The quiescent power supply current depends on the offset voltage when a practical load is connected to the amplifier.
- When driving  $3\Omega$  or  $4\Omega$  loads, the SGM4863 must be mounted to a circuit board that has a minimum of  $2.5in^2$  of exposed, uninterrupted copper area connected to the package's exposed DAP.

TYPICAL PERFORMANCE CHARACTERISTICS

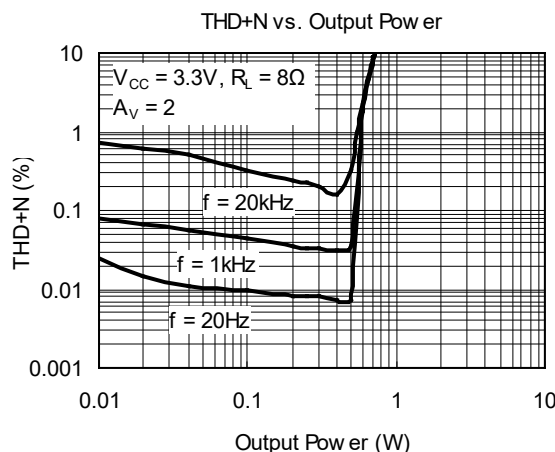
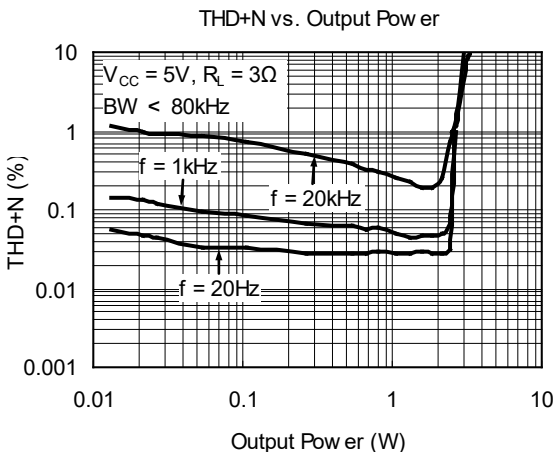
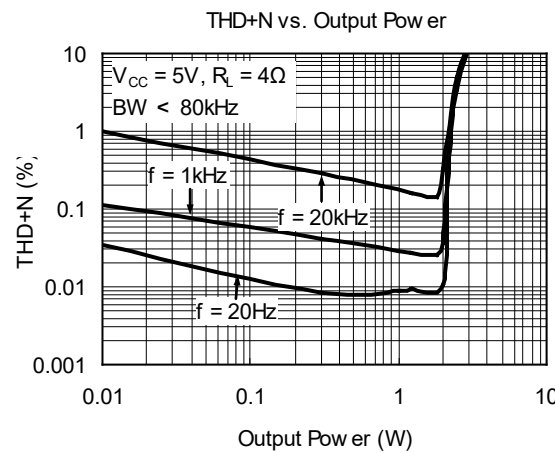
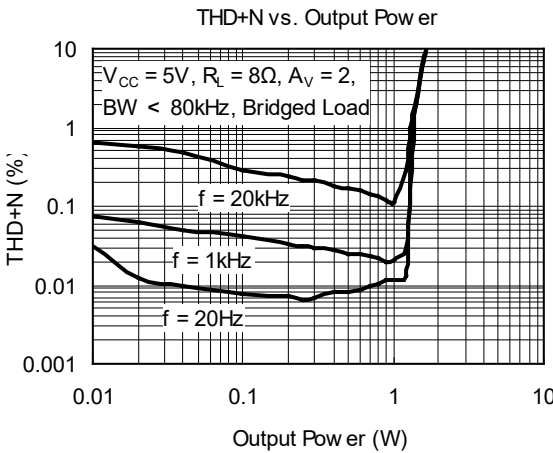
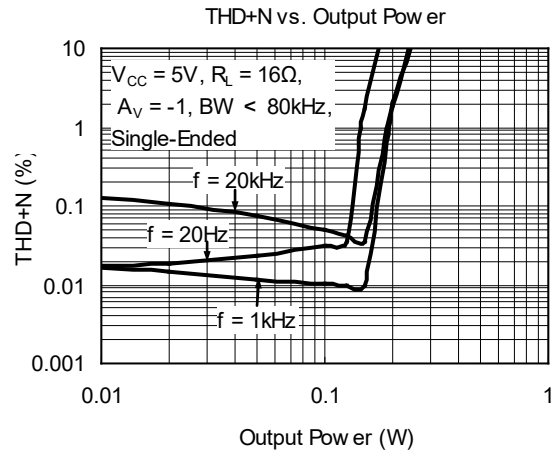
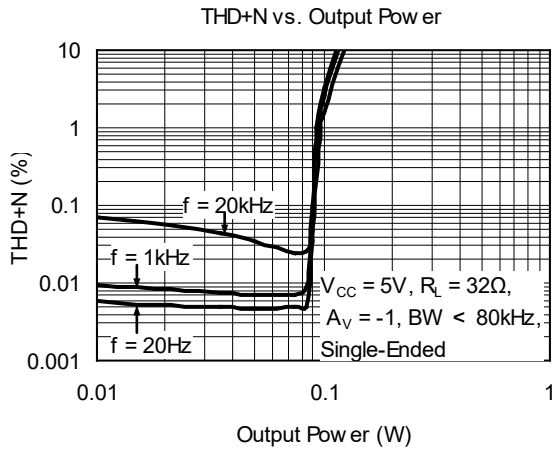

TYPICAL PERFORMANCE CHARACTERISTICS (continued)

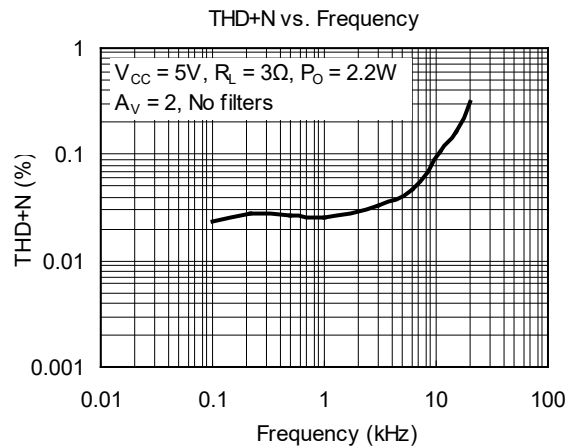
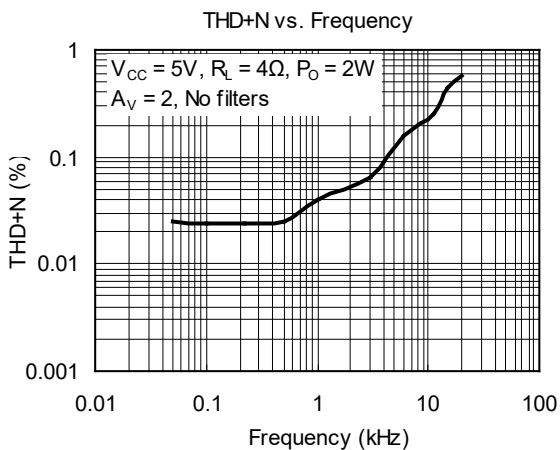
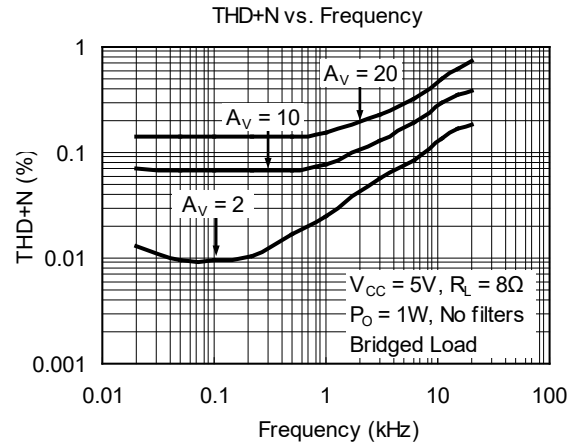
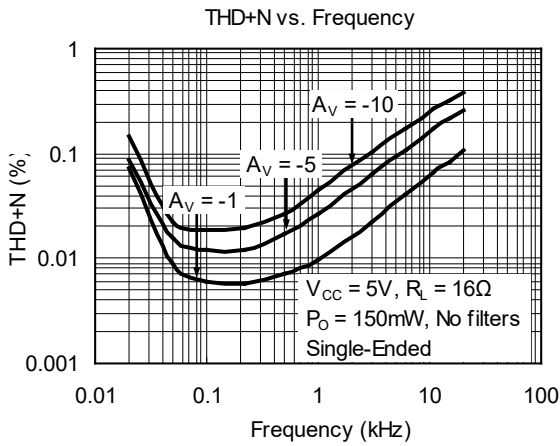
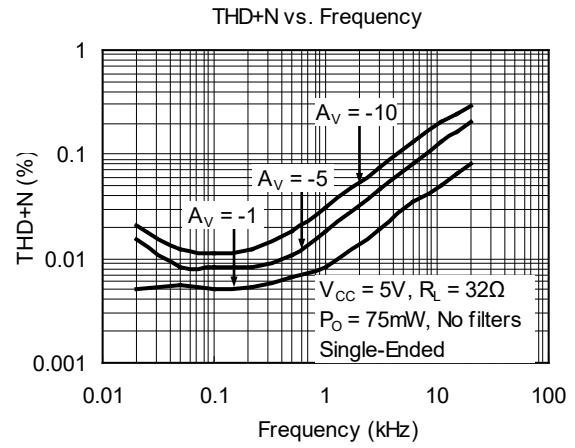
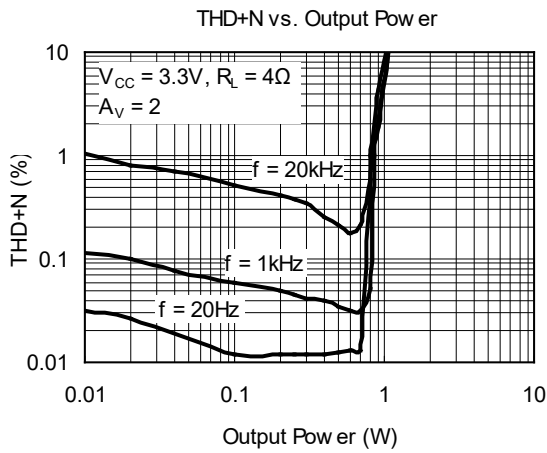

TYPICAL PERFORMANCE CHARACTERISTICS (continued)

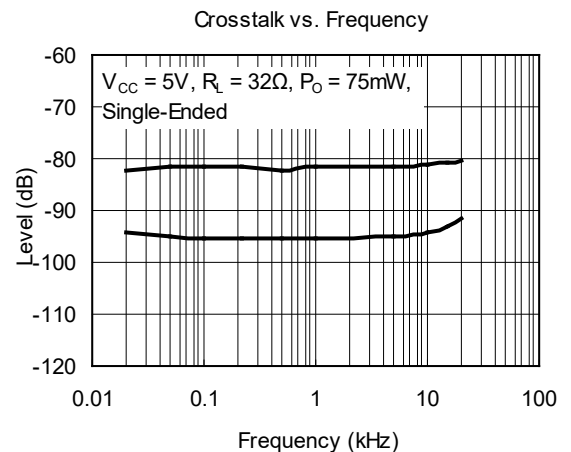
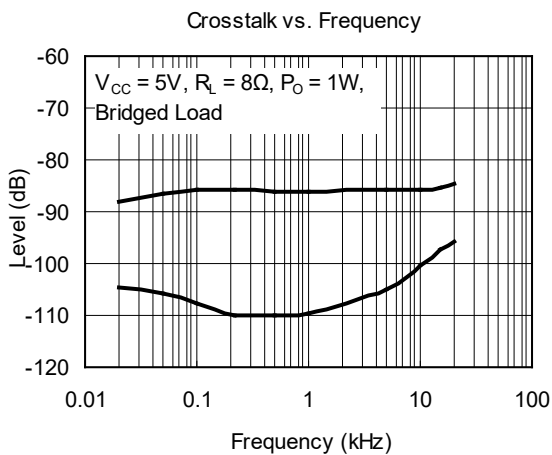
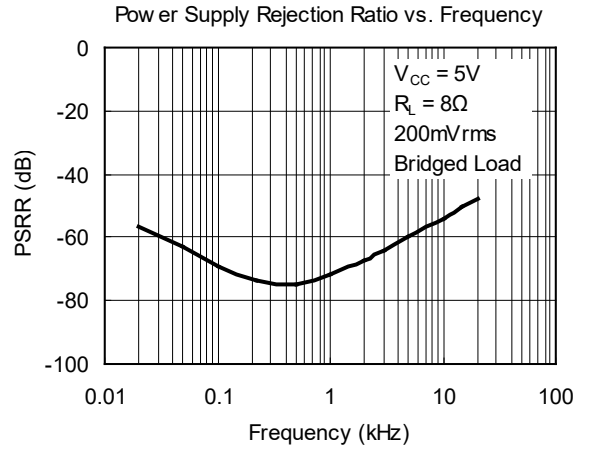
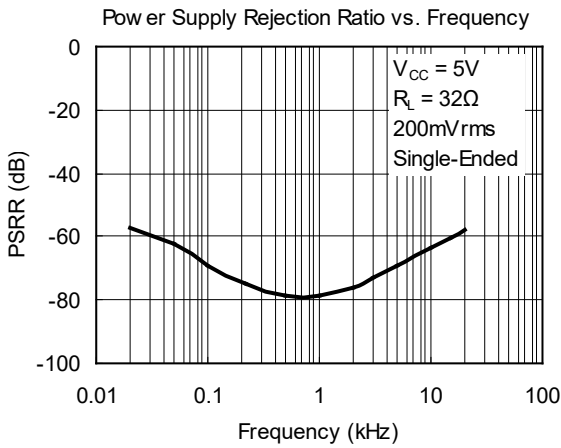
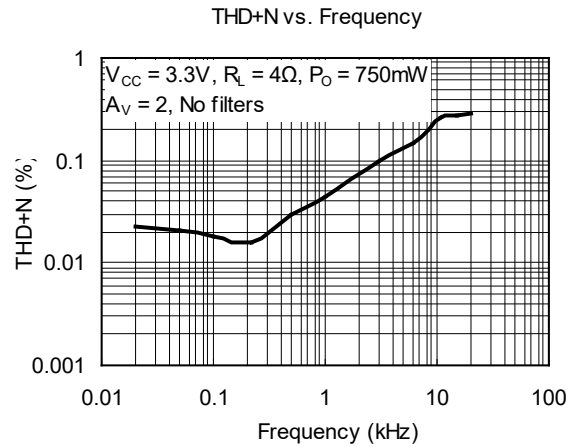
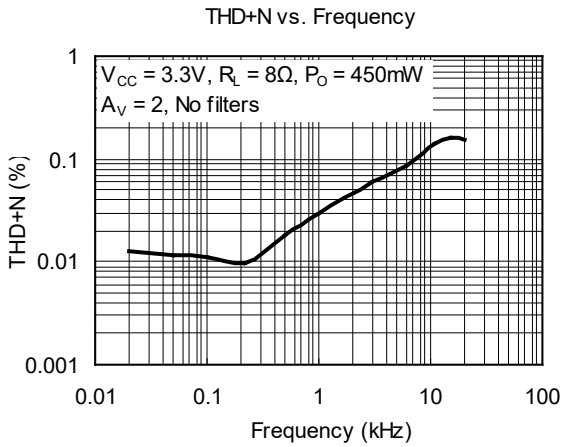

TYPICAL PERFORMANCE CHARACTERISTICS (continued)

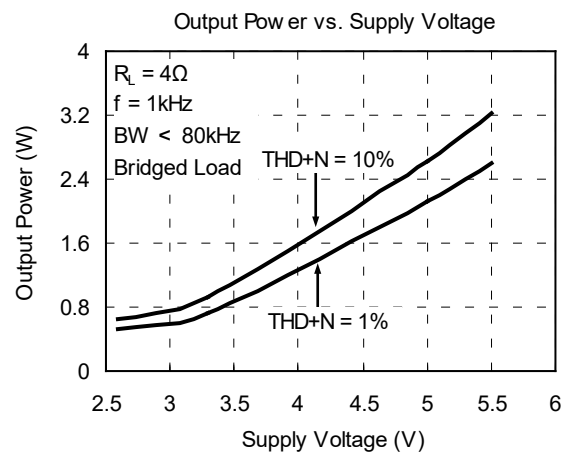
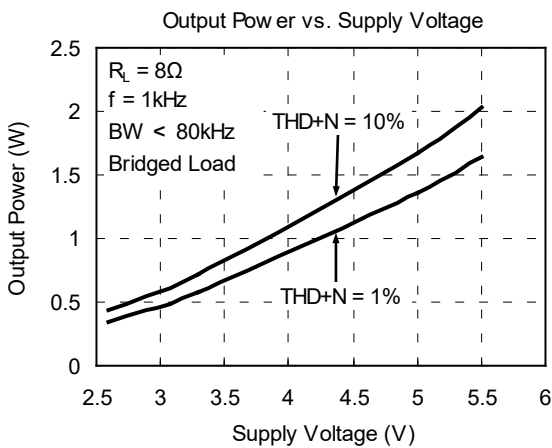
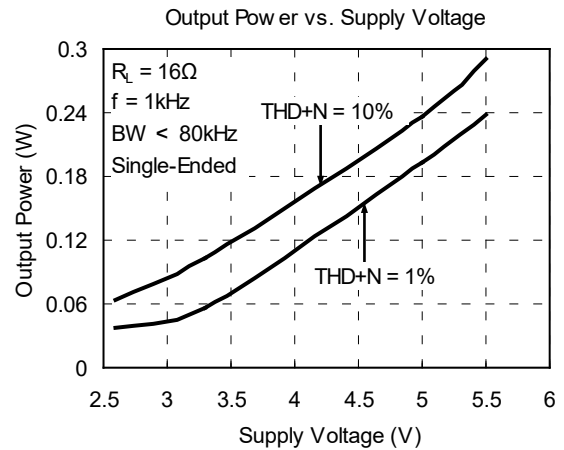
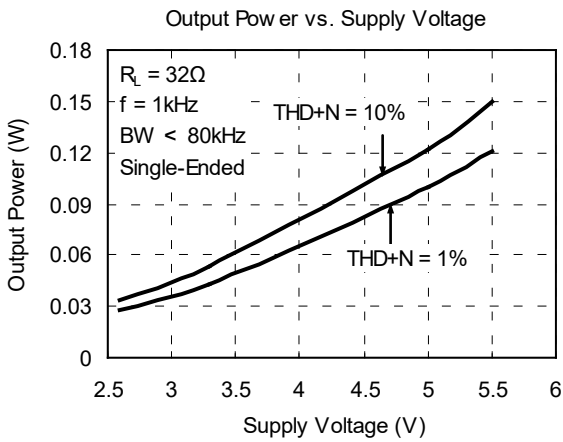
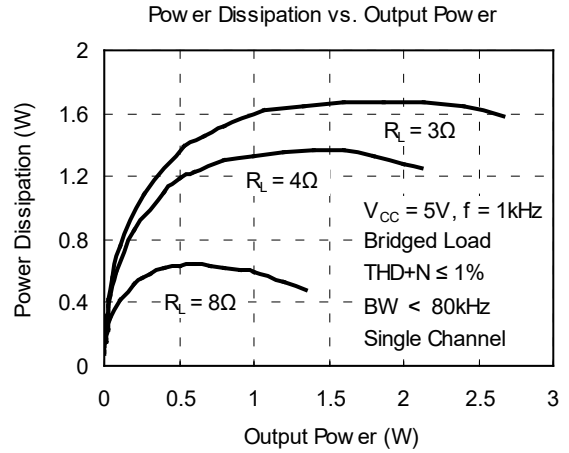
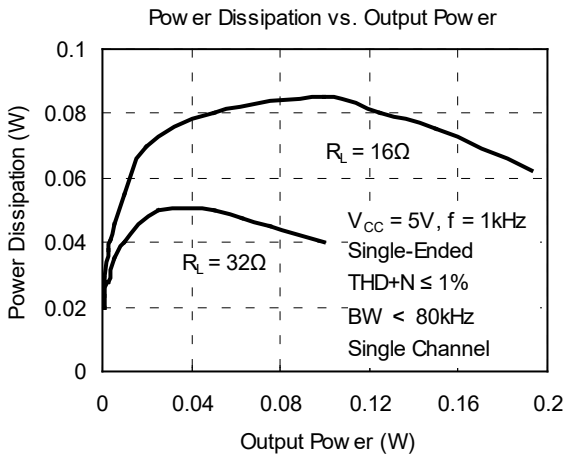



TYPICAL PERFORMANCE CHARACTERISTICS

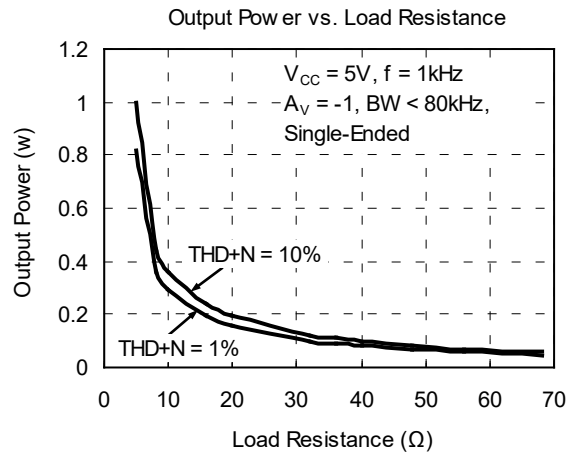
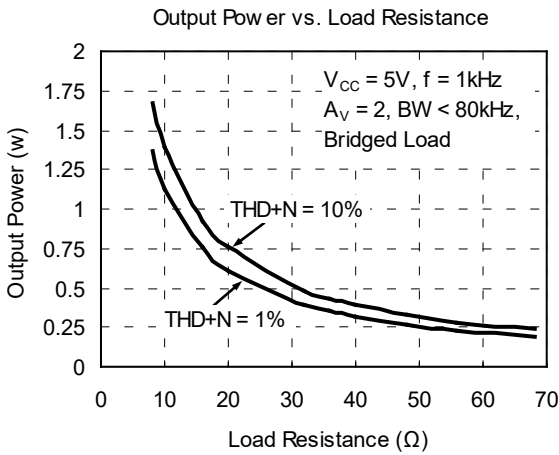
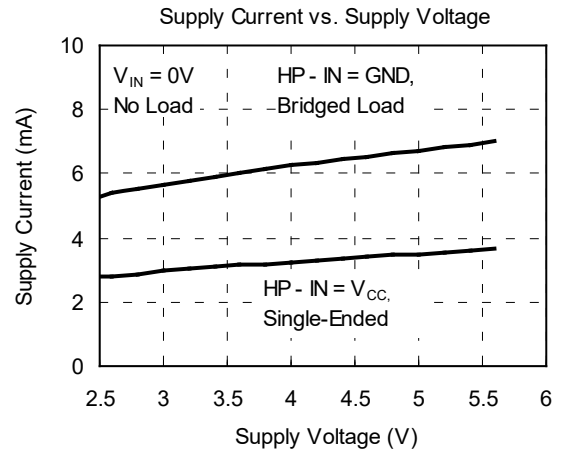
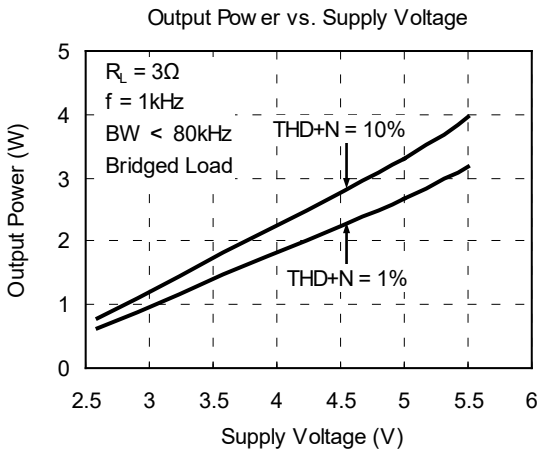

PACKAGE OUTLINE DIMENSIONS

TSSOP-20 (Exposed Pad)

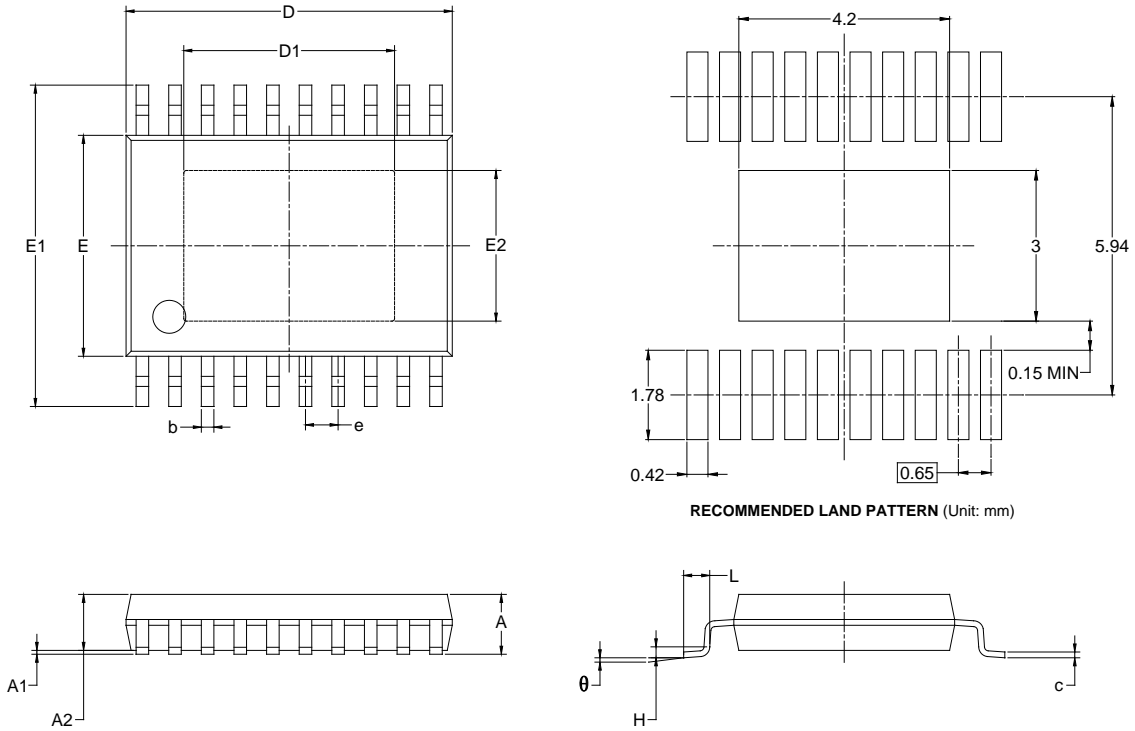

RECOMMENDED LAND PATTERN (Unit: mm)

Symbol	Dimensions In Millimeters		Dimensions In Inches	
	MIN	MAX	MIN	MAX
A		1.100		0.043
A1	0.050	0.150	0.002	0.006
A2	0.800	1.000	0.031	0.039
b	0.190	0.300	0.007	0.012
c	0.090	0.200	0.004	0.008
D	6.400	6.600	0.252	0.259
D1	4.100	4.300	0.165	0.169
E	4.300	4.500	0.169	0.177
E1	6.250	6.550	0.246	0.258
E2	2.900	3.100	0.114	0.122
e	0.650 BSC		0.026 BSC	
L	0.500	0.700	0.02	0.028
H	0.25 TYP		0.01 TYP	
θ	1°	7°	1°	7°

- NOTES:  
 1. Body dimensions do not include mode flash or protrusion.  
 2. This drawing is subject to change without notice.

PACKAGE OUTLINE DIMENSIONS

TQFN-3x3-20L

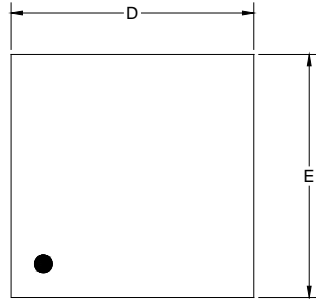

TOP VIEW

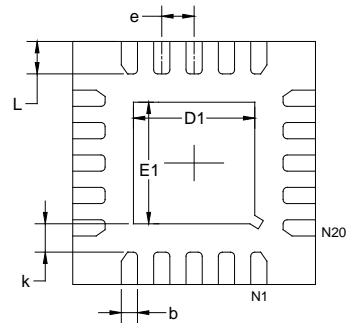

BOTTOM VIEW

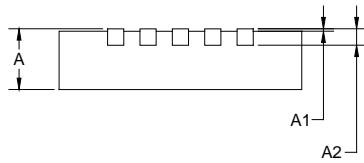

SIDE VIEW

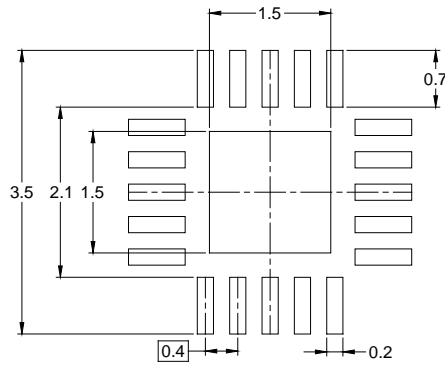

RECOMMENDED LAND PATTERN (Unit: mm)

Symbol	Dimensions In Millimeters		Dimensions In Inches	
	MIN	MAX	MIN	MAX
A	0.700	0.800	0.028	0.031
A1	0.000	0.050	0.000	0.002
A2	0.203 REF		0.008 REF	
D	2.924	3.076	0.115	0.121
D1	1.400	1.600	0.055	0.063
E	2.924	3.076	0.115	0.121
E1	1.400	1.600	0.055	0.063
k	0.200 MIN		0.008 MIN	
b	0.150	0.250	0.006	0.010
e	0.400 TYP		0.016 TYP	
L	0.324	0.476	0.013	0.019

NOTE: This drawing is subject to change without notice.

PACKAGE OUTLINE DIMENSIONS

TSSOP-16 (Exposed Pad)

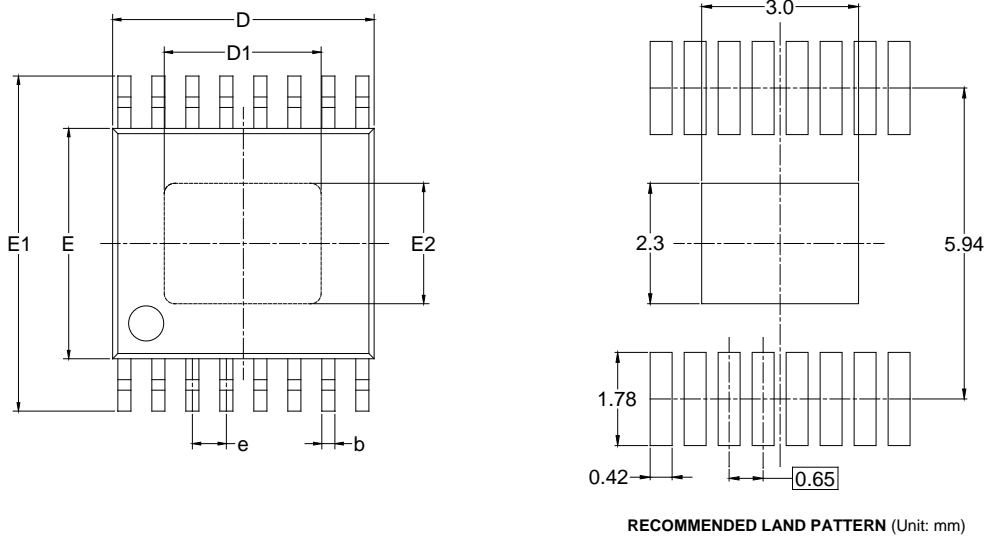

Symbol	Dimensions In Millimeters		Dimensions In Inches	
	MIN	MAX	MIN	MAX
A		1.100		0.043
A1	0.050	0.150	0.002	0.006
A2	0.800	1.000	0.031	0.039
b	0.190	0.300	0.007	0.012
c	0.090	0.200	0.004	0.008
D	4.900	5.100	0.193	0.201
D1	2.900	3.100	0.114	0.122
E	4.300	4.500	0.169	0.177
E1	6.250	6.550	0.246	0.258
E2	2.200	2.400	0.087	0.094
e	0.650 BSC		0.026 BSC	
L	0.500	0.700	0.02	0.028
H	0.25 TYP		0.01 TYP	
θ	1°	7°	1°	7°

NOTES:  
 1. Body dimensions do not include mode flash or protrusion.  
 2. This drawing is subject to change without notice.

PACKAGE OUTLINE DIMENSIONS

DIP-16

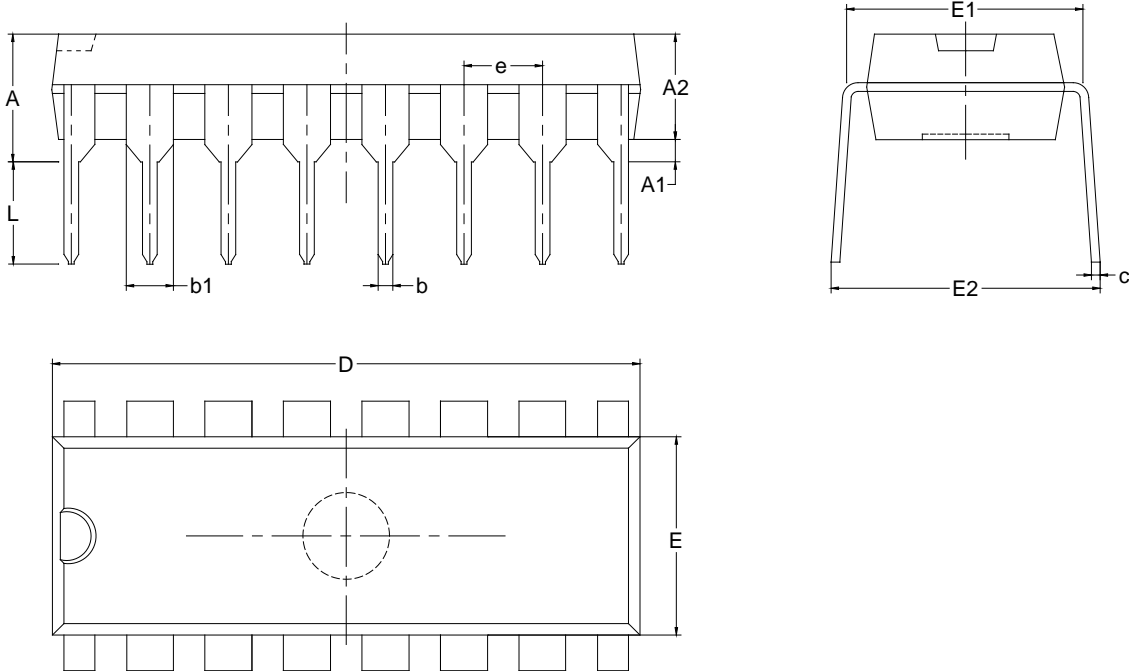

Symbol	Dimensions In Millimeters		Dimensions In Inches	
	MIN	MAX	MIN	MAX
A	3.710	4.310	0.146	0.170
A1	0.510		0.020	
A2	3.200	3.600	0.126	0.142
b	0.380	0.570	0.015	0.022
b1	1.524 BSC		0.060 BSC	
c	0.204	0.360	0.008	0.014
D	18.800	19.200	0.740	0.756
E	6.200	6.600	0.244	0.260
E1	7.320	7.920	0.288	0.312
e	2.540 BSC		0.100 BSC	
L	3.000	3.600	0.118	0.142
E2	8.400	9.000	0.331	0.354

- NOTES:  
 1. Body dimensions do not include mode flash or protrusion.  
 2. This drawing is subject to change without notice.

# PACKAGE INFORMATION

## TAPE AND REEL INFORMATION

### REEL DIMENSIONS

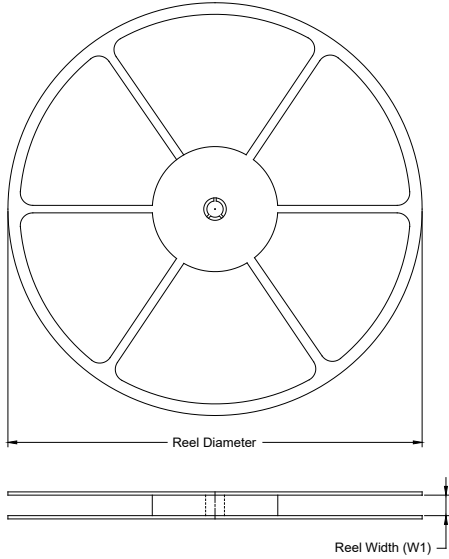

### TAPE DIMENSIONS



NOTE: The picture is only for reference. Please make the object as the standard.

### KEY PARAMETER LIST OF TAPE AND REEL

Package Type	Reel Diameter	Reel Width W1 (mm)	A0 (mm)	B0 (mm)	K0 (mm)	P0 (mm)	P1 (mm)	P2 (mm)	W (mm)	Pin1 Quadrant
TSSOP-20 (Exposed Pad)	13"	12.4	6.80	6.85	1.70	4.0	8.0	2.0	12.0	Q1
TQFN-3×3-20L	13"	12.4	3.30	3.30	1.10	4.0	8.0	2.0	12.0	Q1
TSSOP-16 (Exposed Pad)	13"	12.4	6.90	5.60	1.20	4.0	8.0	2.0	12.0	Q1
SOIC-16	13"	16.4	6.50	10.30	2.10	4.0	8.0	2.0	16.0	Q1

DD0001

# PACKAGE INFORMATION

## CARTON BOX DIMENSIONS



NOTE: The picture is only for reference. Please make the object as the standard.

## KEY PARAMETER LIST OF CARTON BOX

Reel Type	Length (mm)	Width (mm)	Height (mm)	Pizza/Carton
13"	386	280	370	5

DD0002

单击下面可查看定价，库存，交付和生命周期等信息

[>>SGMICRO\(圣邦微电子\)](#)