



SGM8909

3Vrms Audio Line Driver with Integrated Filter and Programmable Gain Stage

GENERAL DESCRIPTION

The SGM8909 is a single-ended, 3Vrms stereo audio line driver with integrated audio filter. The device is ideal for single supply applications. Capless design can eliminate output DC-blocking capacitors for less-component count and low-cost.

The SGM8909 is capable of driving 3Vrms into a 600Ω load when V_{CC} is 5V or 30mW into 32Ω headset when V_{CC} is 3.3V. An integrated charge pump generates a negative power rail that provides a clean, pop-free ground offset.

The device has a gain programming pin. With a single resistor from this pin to ground, device gain can be changed to match the line driver and the codec output level. Built-in active mute control, -90dB attenuation, helps for pop-free mute on/off control.

The SGM8909 will be in mute status during power-on blanking time. External mute control can take over the mute status before power-on blanking time is over. The SGM8909 can eliminate power up click-pop noise perfectly. Using the under-voltage protection (UVP) function, SGM8909 will minimize the turn off click-pop noise.

The SGM8909 is available in a Green TSSOP-14 package. It operates over an ambient temperature range of -40°C to +85°C.

FEATURES

- **Supply Voltage: 2.8V to 5.5V**
- **Capless Structure to Eliminate Pop-Clicks and Output DC-Blocking Capacitors**
- **Low Noise, Low THD and Low Crosstalk:**
 - ◆ **SNR = 107dB at Gain = -1, 600Ω Load for 5V V_{CC}**
 - ◆ **Typical V_N = 8.7μVrms from 20Hz to 20kHz at Gain = -1**
 - ◆ **THD+N = 0.007% for 600Ω Load and Gain = -1**
 - ◆ **Crosstalk = -87dB at 1kHz**
- **3Vrms Output Voltage into 600Ω Load for 5V V_{CC}**
- **2Vrms Output Voltage into 600Ω Load for 3.3V V_{CC}**
- **Supports 32Ω Headset: 30mW at V_{CC} = 3.3V**
- **Single-Ended Input and Output**
- **Programmable Gain by Single External Resistor**
- **Active Mute with More than -90dB Attenuation**
- **UVP Function to Eliminate Turn Off Click-Pop Noise**
- **Integrated Audio Filter**
- **Adjustable Power-On Blanking Time to Eliminate Turn-on Click-Pop Noise**
- **Short-Circuit and Thermal Protection**
- **-40°C to +85°C Operating Temperature Range**
- **Available in a Green TSSOP-14 Package**

APPLICATIONS

LCD TVs
Mini/Micro Combo Systems
Soundcards
DVD Players

PACKAGE/ORDERING INFORMATION

MODEL	PACKAGE DESCRIPTION	SPECIFIED TEMPERATURE RANGE	ORDERING NUMBER	PACKAGE MARKING	PACKING OPTION
SGM8909	TSSOP-14	-40°C to +85°C	SGM8909YTS14G/TR	SGM8909 YTS14 XXXXX	Tape and Reel, 4000

NOTE: XXXXXX = Date Code and Vendor Code.

Green (RoHS & HSF): SG Micro Corp defines "Green" to mean Pb-Free (RoHS compatible) and free of halogen substances. If you have additional comments or questions, please contact your SGMICRO representative directly.

ABSOLUTE MAXIMUM RATINGS

Supply Voltage Range -0.3V to 6V
 Input Voltage Range $V_{SS} - 0.3V$ to $V_{DD} + 0.3V$
 \overline{MUTE} to GND -0.3 to $V_{DD} + 0.3V$
 Junction Temperature +150°C
 Storage Temperature Range -65°C to +150°C
 Lead Temperature (Soldering, 10s) +260°C
 ESD Susceptibility
 HBM 8000V
 MM 300V
 CDM 1000V

RECOMMENDED OPERATING CONDITIONS

Supply Voltage Range 2.8V to 5.5V
 Operating Temperature Range -40°C to +85°C

OVERSTRESS CAUTION

Stresses beyond those listed in Absolute Maximum Ratings may cause permanent damage to the device. Exposure to absolute maximum rating conditions for extended periods may affect reliability. Functional operation of the device at any conditions beyond those indicated in the Recommended Operating Conditions section is not implied.

ESD SENSITIVITY CAUTION

This integrated circuit can be damaged if ESD protections are not considered carefully. SGMICRO recommends that all integrated circuits be handled with appropriate precautions. Failure to observe proper handling and installation procedures can cause damage. ESD damage can range from subtle performance degradation to complete device failure. Precision integrated circuits may be more susceptible to damage because even small parametric changes could cause the device not to meet the published specifications.

DISCLAIMER

SG Micro Corp reserves the right to make any change in circuit design, or specifications without prior notice.

PIN CONFIGURATION

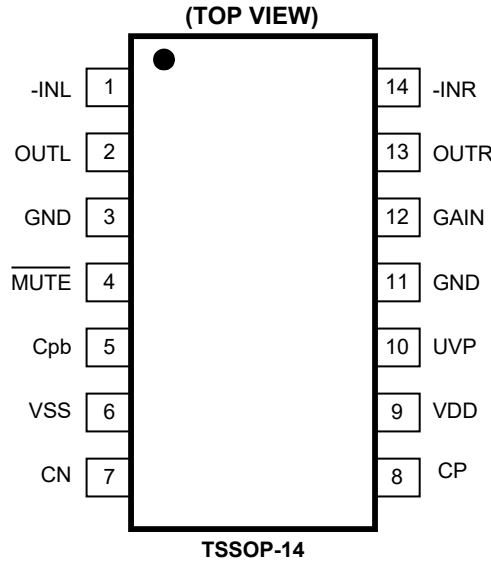

PIN DESCRIPTION

PIN	NAME	FUNCTION
1	-INL	Audio Left Channel Input.
2	OUTL	Audio Left Channel Output.
3, 11	GND	Ground.
4	$\overline{\text{MUTE}}$	Mute Control. Active Low. When $\overline{\text{MUTE}}$ = "Low", chip enters into mute status; when $\overline{\text{MUTE}}$ = "High", chip works normally. There is a 500kΩ pull-low resistor at $\overline{\text{MUTE}}$ pin.
5	Cpb	Power-On Blanking Time Adjusting. Connect one capacitor from Cpb pin to GND to program the power-on blanking time. Chip is in mute status during power-on blanking time.
6	VSS	Charge Pump Output of Negative Power Supply.
7	CN	Negative Terminal for Charge Pump Flying Capacitor.
8	CP	Positive Terminal for Charge Pump Flying Capacitor.
9	VDD	Positive Power Supply Voltage. When VDD under-voltage event happens, chip will enter into mute status.
10	UVP	Under-Voltage Protection Input. When UVP event happens, chip will be in mute status.
12	GAIN	Gain Programming Pin. Connect a resistor from GAIN pin to GND to program the gain of audio R/L channels.
13	OUTR	Audio Right Channel Output.
14	-INR	Audio Right Channel Input.

ELECTRICAL CHARACTERISTICS

(V_{DD} = 3.3V, T_A = +25°C, unless otherwise noted)

PARAMETER	CONDITIONS	MIN	TYP	MAX	UNITS
Electrical Characteristics (V _{DD} = 3.3V, R _L = 600Ω, C _{PUMP} = 1μF, C _{PVSS} = 1μF, C _{pb} = 1nF)					
Output Offset Voltage (V _{OS})			1.5	11	mV
Power Supply Rejection Ratio (PSRR)	V _{DD} = 2.8V to 5.5V		-81		dB
High-Level Output Voltage (V _{OH})	V _{DD} = 3.3V, R _L = 600Ω	3.2			V
Low-Level Output Voltage (V _{OL})	V _{DD} = 3.3V, R _L = 600Ω			-3.04	V
External Under-Voltage Detection (V _{UVP})		1.03	1.12	1.23	V
Supply Current (I _{VDD})	MUTE = 3.3V, no load		11	14.2	mA
	Shutdown mode, MUTE = 0V, no load		3.2	4	
Operating Characteristics (V _{DD} = 3.3V, Gain = -1, C _{PUMP} = 1μF, C _{PVSS} = 1μF, C _{pb} = 1nF)					
Output Voltage, Outputs in Phase (V _o)	f = 1kHz, R _L = 600Ω, THD+N = 1%	2.05			Vrms
Total Harmonic Distortion + Noise (THD+N)	f = 1kHz, BW = 22Hz to 22kHz, R _L = 600Ω, V _o = 2Vrms		0.033		%
	f = 1kHz, BW = 22Hz to 22kHz, R _L = 32Ω, P _o = 30mW		0.1		%
Output Power to 32Ω Headset	f = 1kHz, BW = 22Hz to 22kHz, R _L = 32Ω, THD+N = 0.1%		30		mW
Signal to Noise Ratio (SNR)	f = 1kHz, BW = 22Hz to 22kHz, A-weighted, R _L = 600Ω, V _o = 2Vrms		-107		dB
	f = 1kHz, BW = 22Hz to 22kHz, A-weighted, R _L = 32Ω, P _o = 30mW		-101		dB
Dynamic Range (DNR)	A-weighted, R _L = 600Ω, V _o = 2Vrms		-75		dB
	A-weighted, R _L = 32Ω, P _o = 30mW		-63		dB
Noise Output Voltage (V _N)	A-weighted, BW = 22Hz to 22kHz, f = 1kHz		8.7		μVrms
Input-to-Output Attenuation when Muted	MUTE = GND, R _L = 600Ω, f = 1kHz, 2Vrms input		-90		dB
	MUTE = GND, R _L = 32Ω, f = 1kHz, 1Vrms input		111		dB
Crosstalk	f = 1kHz, R _L = 600Ω, V _o = 2Vrms		-87		dB
	f = 1kHz, R _L = 32Ω, P _o = 30mW		-66		dB
Output Current Limit (I _o)	V _{DD} = 3.3V		83		mA

ELECTRICAL CHARACTERISTICS (continued)(V_{DD} = 5V, T_A = +25°C, unless otherwise noted)

PARAMETER	CONDITIONS	MIN	TYP	MAX	UNITS
Electrical Characteristics (V _{DD} = 5V, R _L = 600Ω, C _{PUMP} = 1μF, C _{PVSS} = 1μF, C _{pb} = 1nF)					
Output Offset Voltage (V _{OS})			1.5	11	mV
High-Level Output Voltage (V _{OH})	V _{DD} = 5V, R _L = 600Ω	4.85			V
Low-Level Output Voltage (V _{OL})	V _{DD} = 5V, R _L = 600Ω			-4.6	V
External Under-Voltage Detection (V _{UVF})		1.03	1.12	1.23	μA
Charge Pump Switching Frequency (f _{CP})		350	470	600	kHz
High-Level Input Current ($\overline{\text{MUTE}}$) (I _{IH})	V _{DD} = 5V, V _I = V _{DD}			1	μA
Low-Level Input Current ($\overline{\text{MUTE}}$) (I _{IL})	V _{DD} = 5V, V _I = 0V			1	μA
External Under-Voltage Detection Hysteresis Current (I _{HYS})			-4.93		μA
Supply Current (I _{VDD})	$\overline{\text{MUTE}}$ = 5V, no load		12	15.5	mA
	Shutdown mode, $\overline{\text{MUTE}}$ = 0V, no load		3.4	4.1	
Operating Characteristics (V _{DD} = 5V, Gain = -1, C _{PUMP} = 1μF, C _{PVSS} = 1μF, C _{pb} = 1nF)					
Output Voltage, Outputs in Phase (V _O)	f = 1kHz, R _L = 600Ω, THD+N = 1%	3.05			Vrms
Total Harmonic Distortion + Noise (THD+N)	f = 1kHz, BW = 22Hz to 22kHz, R _L = 600Ω, V _O = 2Vrms		0.007		%
	f = 1kHz, BW = 22Hz to 22kHz, R _L = 32Ω, P _O = 30mW		0.088		%
Output Power to 32Ω Headset	f = 1kHz, BW = 22Hz to 22kHz, R _L = 32Ω, THD+N = 0.1%		34		mW
Signal to Noise Ratio (SNR)	f = 1kHz, BW = 22Hz to 22kHz, R _L = 600Ω, A-weighted, V _O = 2Vrms		-107		dB
	f = 1kHz, BW = 22Hz to 22kHz, R _L = 32Ω, A-weighted, P _O = 30mW		-101		dB
Dynamic Range (DNR)	A-weighted, R _L = 600Ω, V _O = 2Vrms		-85		dB
	A-weighted, R _L = 32Ω, P _O = 30mW		-64		dB
Noise Output Voltage (V _N)	A-weighted, BW = 22Hz to 22kHz, f = 1kHz		8.7		μVrms
Input-to-Output Attenuation when Muted	$\overline{\text{MUTE}}$ = GND, R _L = 600Ω, f = 1kHz, 2Vrms input		-90		dB
	$\overline{\text{MUTE}}$ = GND, R _L = 32Ω, f = 1kHz, 1Vrms input		111		dB
Crosstalk	f = 1kHz, R _L = 600Ω, V _O = 2Vrms		-87		dB
	f = 1kHz, R _L = 32Ω, P _O = 30mW		-66		dB
Output Current Limit (I _O)	V _{DD} = 5V		142		mA
MUTE Pin					
Input High Voltage (V _{INH})		1.5			V
Input Low Voltage (V _{INL})				0.6	V
Recommended Operating Conditions					
DC Supply Voltage (V _{DD})		2.8		5.5	V

PROGRAMMABLE GAIN SETTINGS (1) (2)

(V_{DD} = 3.3V, T_A = +25°C, R_{LOAD} = 10kΩ, C_{CP} = 1μF, Gain = 1, unless otherwise noted)

PARAMETER	CONDITIONS	MIN	TYP	MAX	UNITS
Gain Programming Resistor Tolerance (R _{TOL})				2	%
Gain Matching (ΔA _v)	Between left and right channels		0.2		dB
Gain Step Tolerance			0.2		dB
Gain Steps	Gain resistor 2% tolerance				V/V
	1000kΩ or higher		-3		
	560kΩ		-1		
	330kΩ		-1.5		
	220kΩ		-2		
	150kΩ		-2.3		
	90.9kΩ		-2.5		
	56kΩ		-3.3		
	39kΩ		-4		
	22kΩ		-5.1		
	15kΩ		-5.5		
	10kΩ		-6.3		
	6.8kΩ		-8.2		
3.9kΩ		-10			
Input Impedance	Gain resistor 2% tolerance				kΩ
			20		

NOTES:

1. The Gain = -3 set by an internal pull-up, when the GAIN pin is left floating.
2. Gain setting is latched during power-up.

TYPICAL PERFORMANCE CHARACTERISTICS

$V_{DD} = 5V$, $T_A = +25^\circ C$, $C_{PUMP} = C_{PVSS} = 1\mu F$, $C_{pb} = 1nF$, $BW = 22Hz$ to $22kHz$, $Gain = -1$, unless otherwise noted.

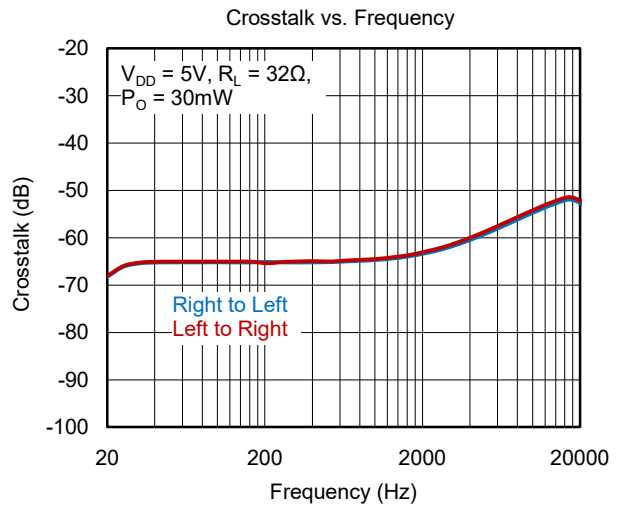
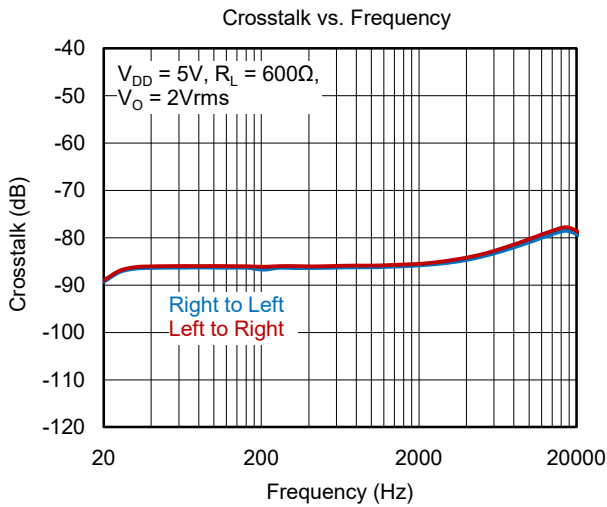
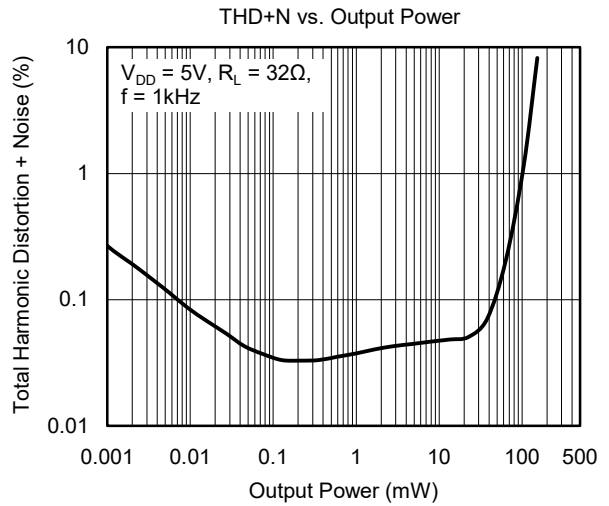
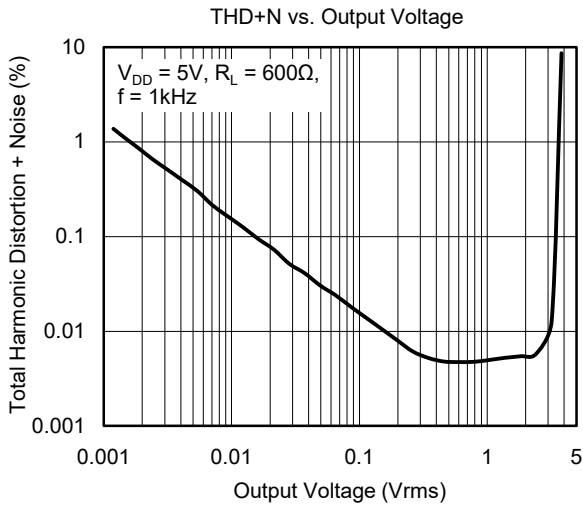
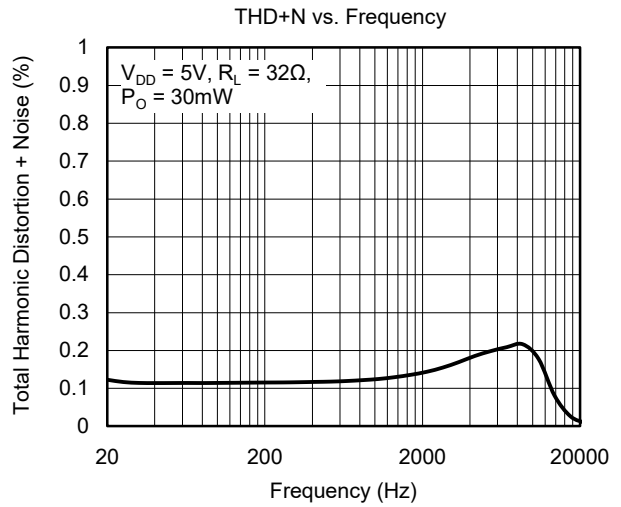
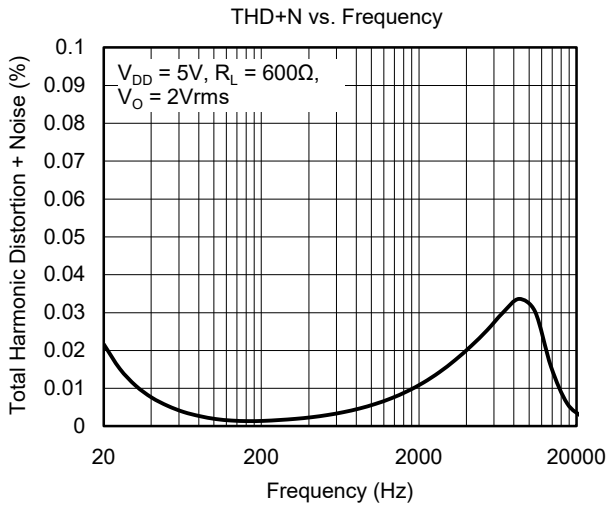

TYPICAL PERFORMANCE CHARACTERISTICS (continued)

V_{DD} = 5V, T_A = +25°C, C_{PUMP} = C_{PVSS} = 1μF, C_{pb} = 1nF, BW = 22Hz to 22kHz, Gain = -1, unless otherwise noted.

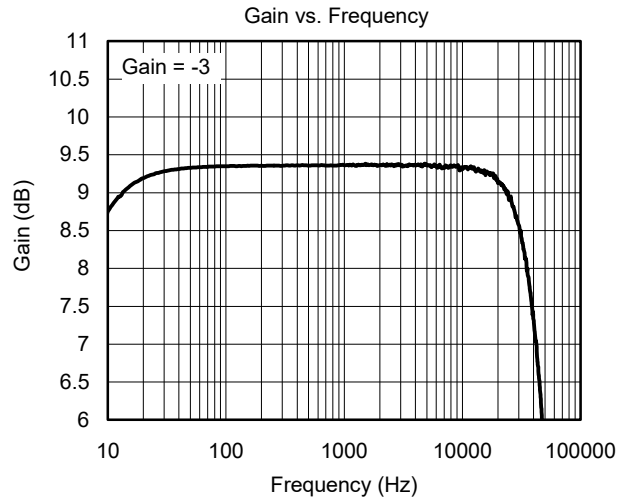
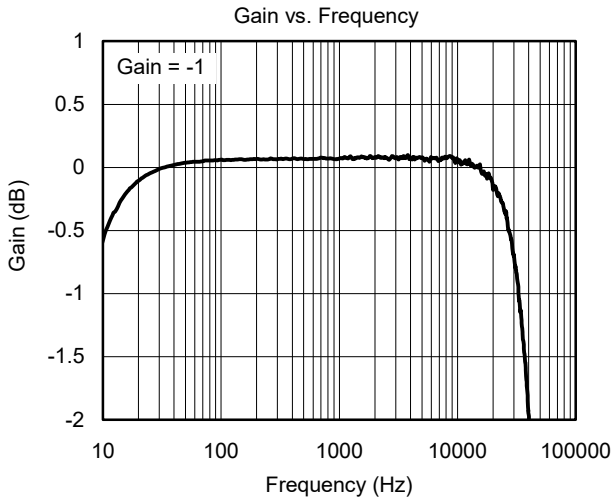

TYPICAL APPLICATION

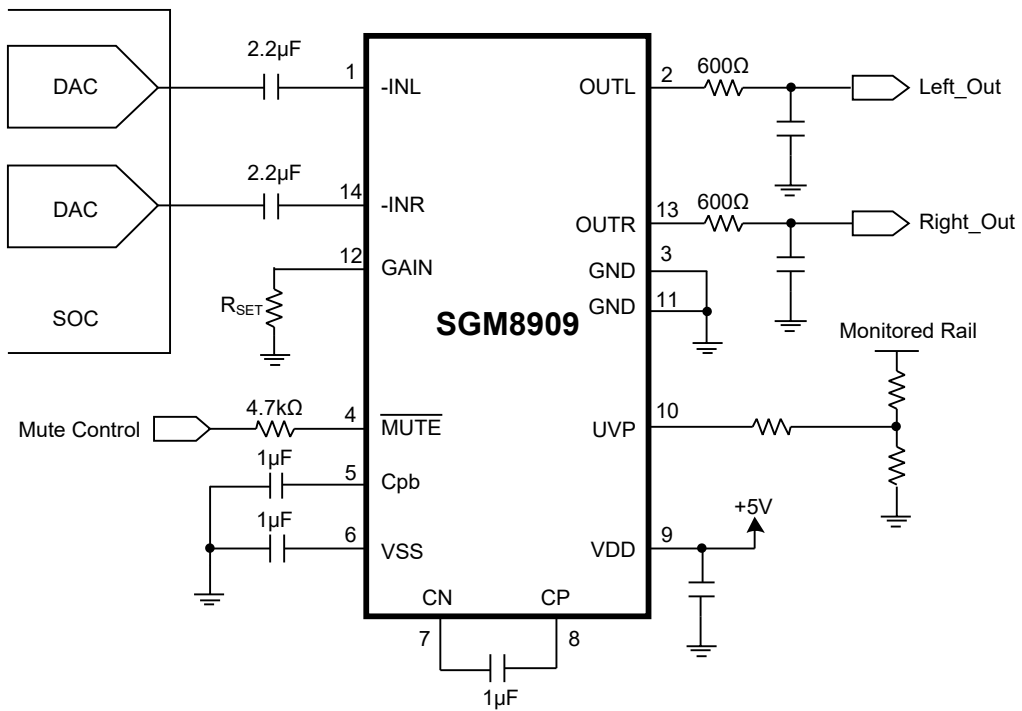

Figure 1. Typical Application Circuit

FUNCTIONAL BLOCK DIAGRAM

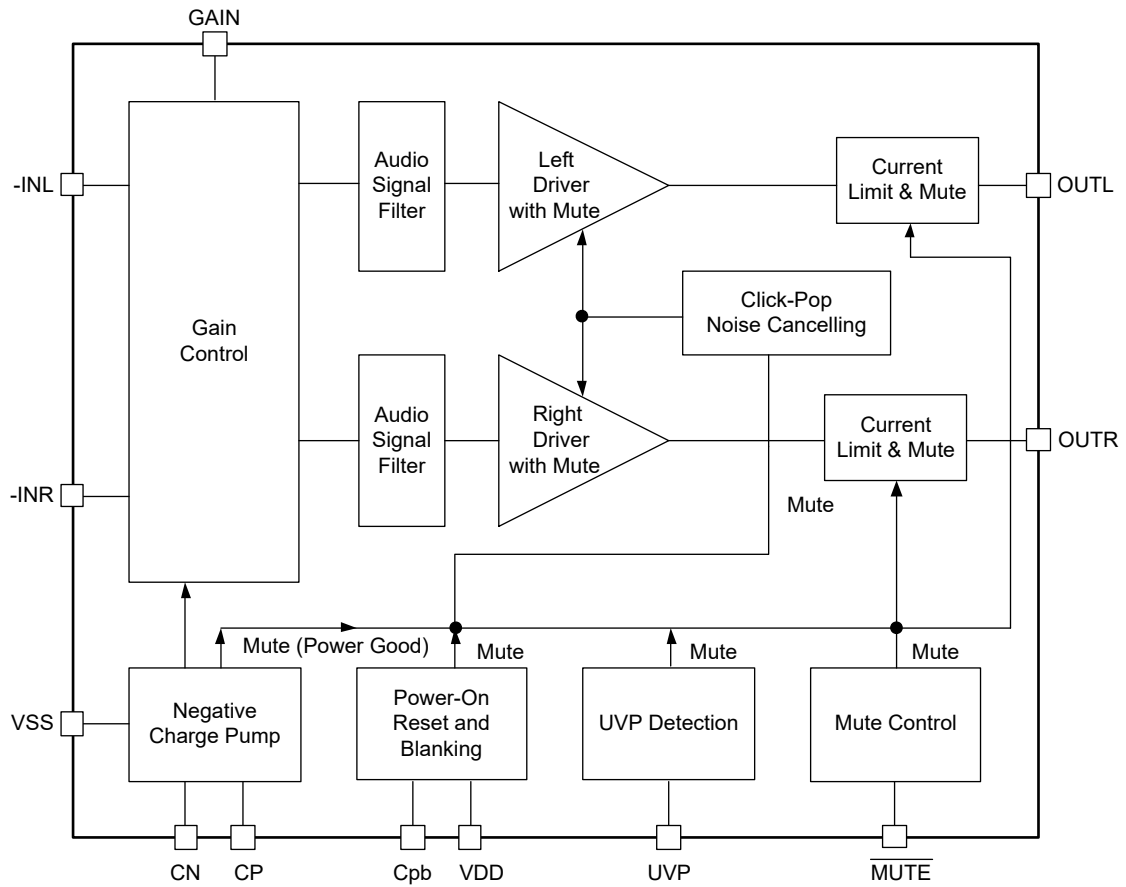

Figure 2. Block Diagram

REVISION HISTORY

NOTE: Page numbers for previous revisions may differ from page numbers in the current version.

Changes from Original (DECEMBER 2016) to REV.A	Page
Changed from product preview to production data.....	All

PACKAGE OUTLINE DIMENSIONS

TSSOP-14

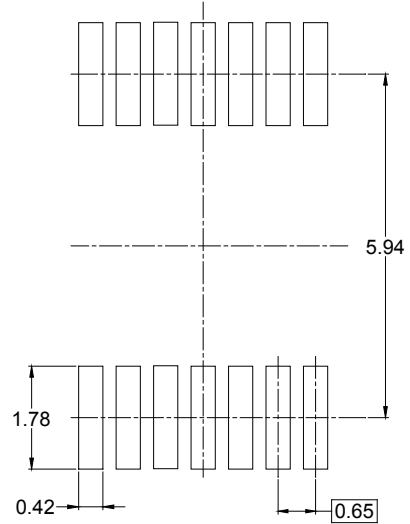
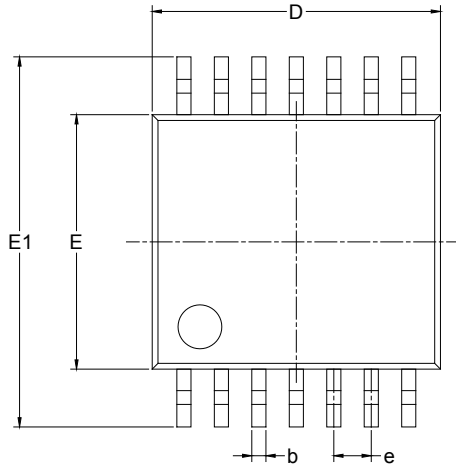

RECOMMENDED LAND PATTERN (Unit: mm)

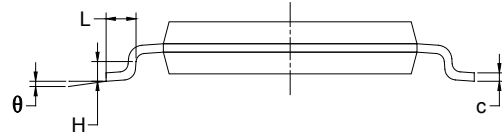
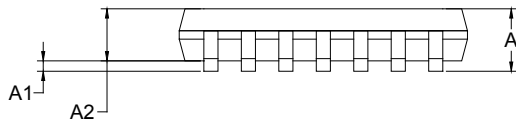

Symbol	Dimensions In Millimeters		Dimensions In Inches	
	MIN	MAX	MIN	MAX
A		1.200		0.047
A1	0.050	0.150	0.002	0.006
A2	0.800	1.050	0.031	0.041
b	0.190	0.300	0.007	0.012
c	0.090	0.200	0.004	0.008
D	4.860	5.100	0.191	0.201
E	4.300	4.500	0.169	0.177
E1	6.250	6.550	0.246	0.258
e	0.650 BSC		0.026 BSC	
L	0.500	0.700	0.02	0.028
H	0.25 TYP		0.01 TYP	
θ	1°	7°	1°	7°

TAPE AND REEL INFORMATION

REEL DIMENSIONS

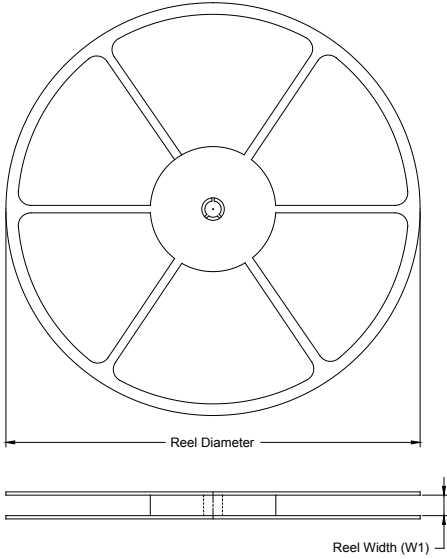

TAPE DIMENSIONS



NOTE: The picture is only for reference. Please make the object as the standard.

KEY PARAMETER LIST OF TAPE AND REEL

Package Type	Reel Diameter	Reel Width W1 (mm)	A0 (mm)	B0 (mm)	K0 (mm)	P0 (mm)	P1 (mm)	P2 (mm)	W (mm)	Pin1 Quadrant
TSSOP-14	13"	12.4	6.95	5.60	1.20	4.0	8.0	2.0	12.0	Q1

000001

PACKAGE INFORMATION

CARTON BOX DIMENSIONS



NOTE: The picture is only for reference. Please make the object as the standard.

KEY PARAMETER LIST OF CARTON BOX

Reel Type	Length (mm)	Width (mm)	Height (mm)	Pizza/Carton
13"	386	280	370	5

DD0002

单击下面可查看定价，库存，交付和生命周期等信息

[>>SGMICRO\(圣邦微电子\)](#)