

GENERAL DESCRIPTION

The SGM42622 is a stepper motor driver with control logic and low $R_{DS(ON)}$ MOSFET power stages all integrated in a small TQFN package.

This device uses fixed off-time PWM current control for two independent H-bridges and is capable for fine microstepping resolution up to 1/256. Aimed for battery-powered applications, it can go to near zero-power standby mode for increased battery life.

A full set of protection features are provided including over-current, short-circuit, and thermal shutdown.

The SGM42622 is available in a Green TQFN-3×3-16L package. It operates over an ambient temperature range of -40°C to +85°C.

FEATURES

- **Motor Power Supply Voltage Range: 1.8V to 10V**
- **Up to 1/256 Microstepping Resolution**
- **1.3A Maximum RMS Output Current**
- **Low $R_{DS(ON)}$: 0.5Ω (HS + LS) at +25°C**
- **Adaptive Mixed Current Decay Modes**
- **Current Control with Programmable Off-Time**
- **Full Set of Protections**
 - ◆ **Lossless Over-Current Protection**
 - ◆ **Short-Circuit Protection**
 - ◆ **Thermal Shutdown**
- **Less than 80nA Standby Current for Long Battery Life**
- **-40°C to +85°C Operating Temperature Range**
- **Available in a Green TQFN-3×3-16L Package**

APPLICATIONS

- Toys
- Robotics
- Portable Printers
- Point of Sale (POS) Devices

TYPICAL APPLICATION

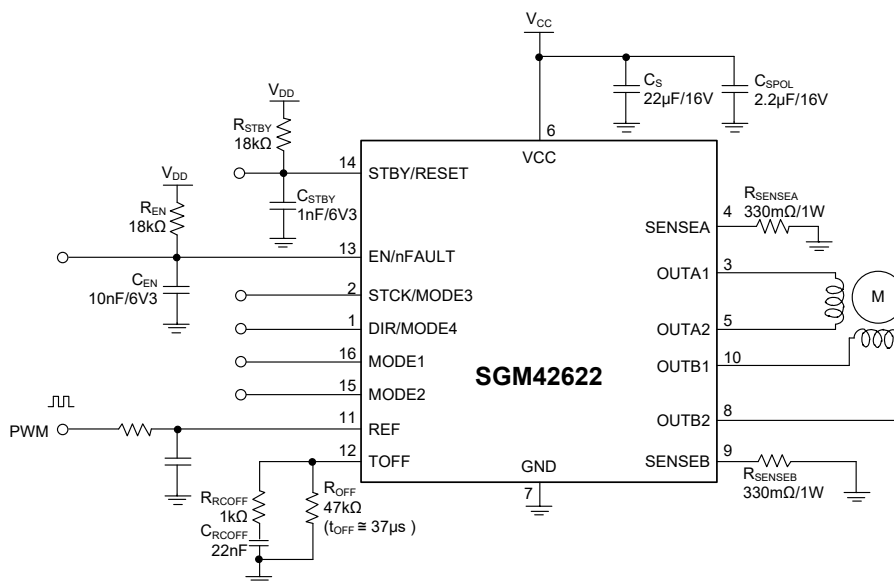

Figure 1. Typical Application Circuit

PACKAGE/ORDERING INFORMATION

MODEL	PACKAGE DESCRIPTION	SPECIFIED TEMPERATURE RANGE	ORDERING NUMBER	PACKAGE MARKING	PACKING OPTION
SGM42622	TQFN-3×3-16L	-40°C to +85°C	SGM42622YTQ16G/TR	42622TQ XXXXX	Tape and Reel, 4000

MARKING INFORMATION

NOTE: XXXXX = Date Code, Trace Code and Vendor Code.

XXXXX

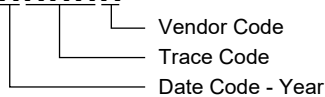

Green (RoHS & HSF): SG Micro Corp defines "Green" to mean Pb-Free (RoHS compatible) and free of halogen substances. If you have additional comments or questions, please contact your SGMICRO representative directly.

ABSOLUTE MAXIMUM RATINGS

Supply Voltage, V_{CC}	-0.3V to 11V
Logic Input Voltage	-0.3V to 5.5V
Output-to-Sense Voltage Drop, $V_{OUT} - V_{SENSE}$	11V
Supply-to-Output Voltage Drop, $V_{CC} - V_{OUT}$	11V
Sense Pin Voltage, V_{SENSE}	-1V to 1V
Input Reference Voltage, V_{REF}	-0.3V to 1V
Continuous Power Stage Output Current (Each Bridge)	
$I_{OUT, RMS}$	1.3A _{RMS}
Power Dissipation, $P_D @ T_A = +25^\circ C$	
TQFN-3×3-16L.....	1.5W
Junction Temperature.....	+150°C
Storage Temperature Range	-65°C to +150°C
Lead Temperature (Soldering, 10s).....	+260°C
ESD Susceptibility	
HBM.....	4000V
CDM	1000V

RECOMMENDED OPERATING CONDITIONS

Supply Voltage, V_{CC}	1.8V to 10V
Logic Input Voltage	0V to 5V
Input Reference Voltage, V_{REF}	0.1V to 0.5V
Logic Inputs Positive/Negative Pulse Width, t_{INW}	> 300ns
Operating Temperature Range	-40°C to +85°C

OVERSTRESS CAUTION

Stresses beyond those listed in Absolute Maximum Ratings may cause permanent damage to the device. Exposure to absolute maximum rating conditions for extended periods may affect reliability. Functional operation of the device at any conditions beyond those indicated in the Recommended Operating Conditions section is not implied.

ESD SENSITIVITY CAUTION

This integrated circuit can be damaged if ESD protections are not considered carefully. SGMICRO recommends that all integrated circuits be handled with appropriate precautions. Failure to observe proper handling and installation procedures can cause damage. ESD damage can range from subtle performance degradation to complete device failure. Precision integrated circuits may be more susceptible to damage because even small parametric changes could cause the device not to meet the published specifications.

DISCLAIMER

SG Micro Corp reserves the right to make any change in circuit design, or specifications without prior notice.

PIN CONFIGURATION

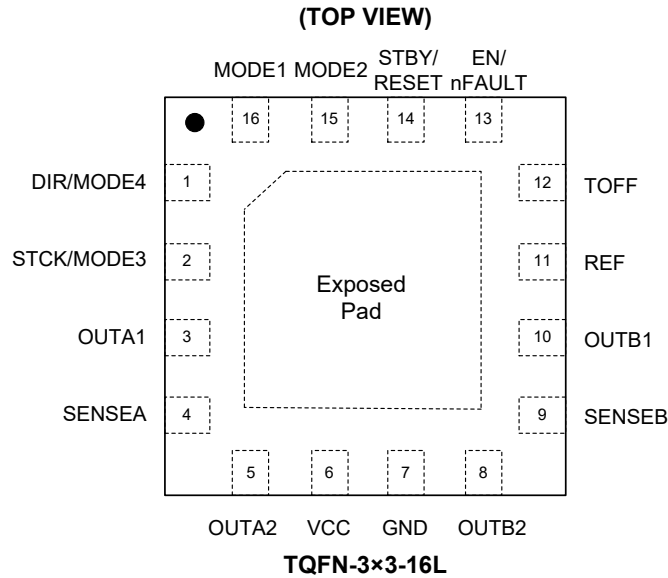

PIN DESCRIPTION

PIN	NAME	TYPE	FUNCTION
1	DIR/MODE4	Logic Input	Direction Input or Step Mode Selection Input 4.
2	STCK/MODE3	Logic Input	Step Clock Input or Step Mode Selection Input 3.
3	OUTA1	Power Output	Output Power Bridge A1.
4	SENSEA	Power Output	Sense Output of the Bridge A. Connect with a small sensing resistor to power ground.
5	OUTA2	Power Output	Output Power Bridge A2.
6	VCC	Supply	Device Supply Voltage.
7	GND	Ground	Device Ground.
8	OUTB2	Power Output	Output Power Bridge B2.
9	SENSEB	Power Output	Sense Output of the Bridge B. Connect with a small sensing resistor to power ground.
10	OUTB1	Power Output	Output Power Bridge B1.
11	REF	Analog Input	Reference Voltage Input for the PWM Current Control.
12	TOFF	Analog Input	Internal Oscillator Frequency Adjustment.
13	EN/nFAULT	Logic Input/ Open-Drain Output	5V Logic-Compliant Power Stage Enable Input or Alert Output. Power stage is turned off if it is not pulled high. This pin is also the device fault output with internal open-drain driver. If a fault occurs, it will be pulled down internally.
14	STBY/RESET	Logic Input	5V Logic-Compliant Standby Input. Device goes to low power mode if pulled low.
15	MODE2	Logic Input	Step Mode Selection Input 2.
16	MODE1	Logic Input	Step Mode Selection Input 1.
Exposed Pad	GND	Ground	Device Ground. The exposed pad must be connected to ground.

ELECTRICAL CHARACTERISTICS

(T_A = +25°C and V_{CC} = 5V, unless otherwise noted.)

PARAMETER	SYMBOL	CONDITIONS	MIN	TYP	MAX	UNITS
Power Supplies						
Power Supply Voltage	V _{CC}		1.8		10	V
V _{CC} Turn-On Voltage	V _{CCTH_ON}	V _{CC} rising from 0V	1.1	1.47	1.8	V
V _{CC} Turn-Off Voltage	V _{CCTH_OFF}	V _{CC} falling from 5V	1	1.31	1.64	V
V _{CC} Hysteresis Voltage	V _{CCTH_HYS}			180		mV
V _{CC} Supply Current	I _{CC}	No commutations, EN = low, R _{OFF} = 160kΩ		2700	3500	μA
		No commutations, EN = high, R _{OFF} = 160kΩ		2800	3650	μA
V _{CC} Standby Current	I _{CC_STBY}	V _{STBY} = 0V		10	80	nA
Standby Low Logic Level Input Voltage	V _{STBYL}				0.7	V
Standby High Logic Level Input Voltage	V _{STBYH}		2.25			V
Power Stage						
Total On-Resistance (HS + LS)	R _{DS(ON)}	V _{CC} = 10V, I _{OUT} = 1.3A		0.43	0.6	Ω
		V _{CC} = 3V, I _{OUT} = 0.4A		0.5	0.65	
Rise Time	t _{RISE}	V _{CC} = 10V, unloaded outputs		40		ns
Fall Time	t _{FALL}	V _{CC} = 10V, unloaded outputs		40		ns
Dead Time	t _{DT}			260		ns
Current Control						
Sensing Offset	V _{SENSE_OFFSET}	V _{REF} = 0.5V, internal reference 20% V _{REF}	-15		15	mV
Total Off-Time	t _{OFF}	R _{OFF} = 10kΩ		9		μs
		R _{OFF} = 160kΩ		106		μs
Slow Decay Time	t _{OFF_SLOW}			5/8 × t _{OFF}		μs
Fast Decay Time	t _{OFF_FAST}			3/8 × t _{OFF}		μs
Logic IOs						
High Logic Level Input Voltage	V _{IH}		1.5			V
Low Logic Level Input Voltage	V _{IL}				0.5	V
EN Low Logic Level Output Voltage	V _{OL}	I _{EN} = 4mA			0.8	V
STBY Pull-Down Resistance	R _{STBY}			72		kΩ
EN Pull-Down Current	I _{PDEN}			12		μA

ELECTRICAL CHARACTERISTICS (continued)(T_A = +25°C and V_{CC} = 5V, unless otherwise noted.)

PARAMETER	SYMBOL	CONDITIONS	MIN	TYP	MAX	UNITS
EN Input Propagation Delay	t _{ENd}	From EN falling edge to OUT high-impedance		2000		ns
MODEx Input Hold Time	t _{MODEho}	From STBY edge	200			μs
MODEx Input Setup Time	t _{MODEsu}	From STBY edge	2			μs
DIR Input Hold Time	t _{DIRho}	From STCK rising edge	200			ns
DIR Input Setup Time	t _{DIRsu}	From STCK rising edge	200			ns
STCK High Time	t _{STCKH}		200			ns
STCK Low Time	t _{STCKL}		200			ns
STCK Inputs Frequency	f _{STCK}				1	MHz
OCP Retry Time	t _{OCP_RETRY}			16		ms
Protections						
Thermal Shutdown Threshold	T _{TSD}			170		°C
Thermal Shutdown Hysteresis	T _{HYS}			40		°C
Over-Current Protection Threshold	I _{OCP}			2		A

TYPICAL PERFORMANCE CHARACTERISTICS

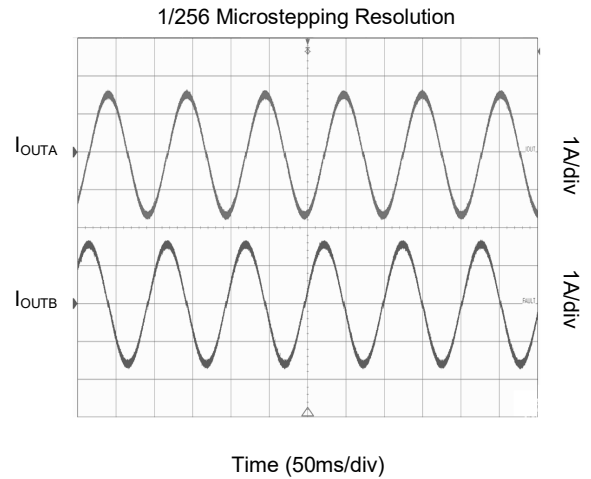
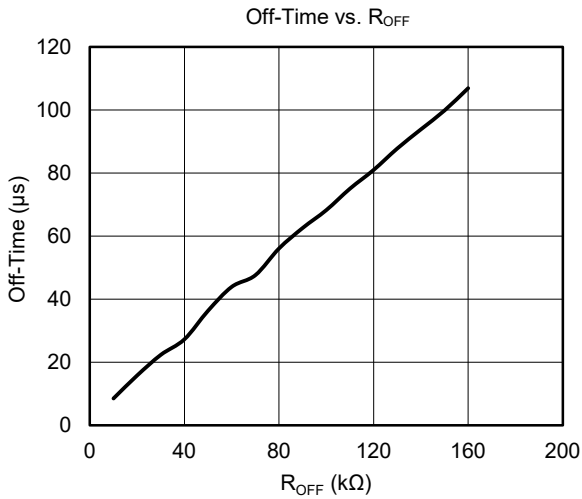
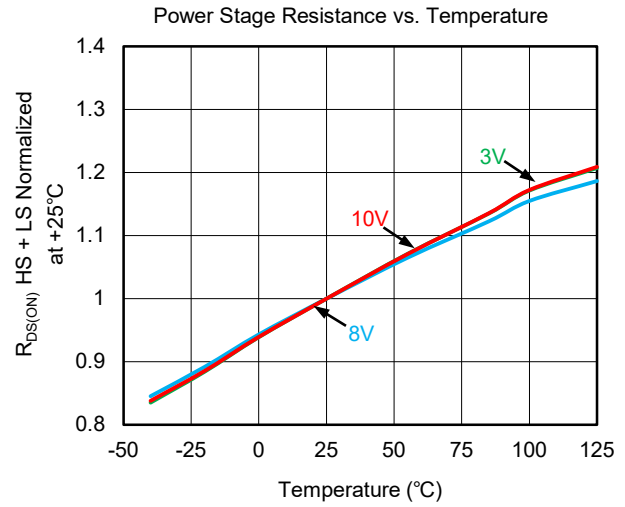
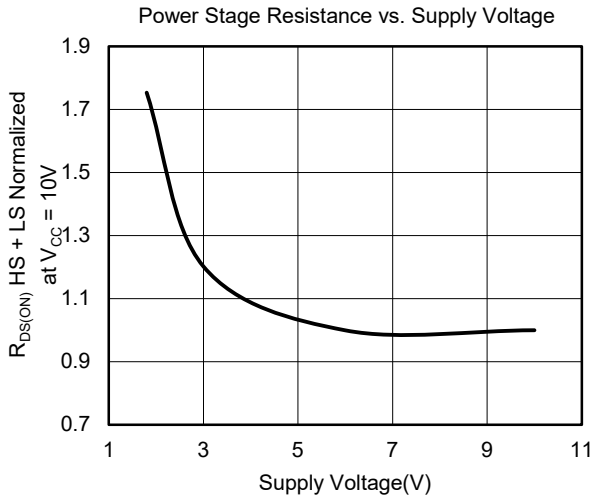

REVISION HISTORY

NOTE: Page numbers for previous revisions may differ from page numbers in the current version.

Changes from Original (DECEMBER 2020) to REV.A	Page
Changed from product preview to production data.....	All

PACKAGE INFORMATION

PACKAGE OUTLINE DIMENSIONS

TQFN-3×3-16L

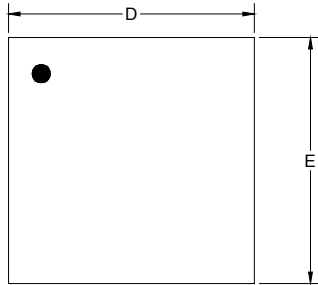

TOP VIEW

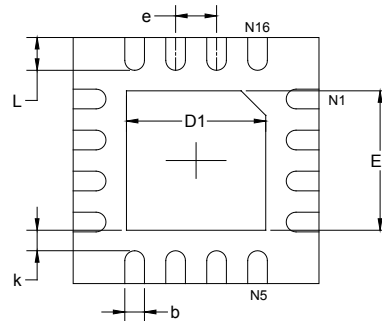

BOTTOM VIEW

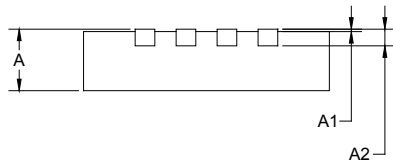

SIDE VIEW

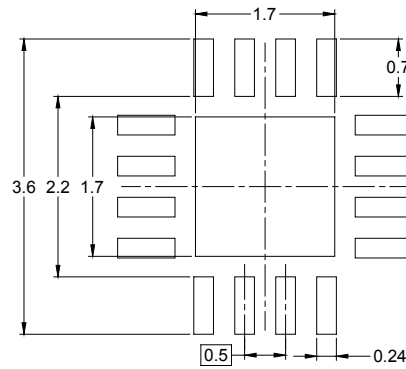

RECOMMENDED LAND PATTERN (Unit: mm)

Symbol	Dimensions In Millimeters		Dimensions In Inches	
	MIN	MAX	MIN	MAX
A	0.700	0.800	0.028	0.031
A1	0.000	0.050	0.000	0.002
A2	0.203 REF		0.008 REF	
D	2.900	3.100	0.114	0.122
D1	1.600	1.800	0.063	0.071
E	2.900	3.100	0.114	0.122
E1	1.600	1.800	0.063	0.071
k	0.200 MIN		0.008 MIN	
b	0.180	0.300	0.007	0.012
e	0.500 TYP		0.020 TYP	
L	0.300	0.500	0.012	0.020

PACKAGE INFORMATION

TAPE AND REEL INFORMATION

REEL DIMENSIONS



TAPE DIMENSIONS



NOTE: The picture is only for reference. Please make the object as the standard.

KEY PARAMETER LIST OF TAPE AND REEL

Package Type	Reel Diameter	Reel Width W1 (mm)	A0 (mm)	B0 (mm)	K0 (mm)	P0 (mm)	P1 (mm)	P2 (mm)	W (mm)	Pin1 Quadrant
TQFN-3×3-16L	13"	12.4	3.35	3.35	1.13	4.0	8.0	2.0	12.0	Q2

000001

PACKAGE INFORMATION

CARTON BOX DIMENSIONS



NOTE: The picture is only for reference. Please make the object as the standard.

KEY PARAMETER LIST OF CARTON BOX

Reel Type	Length (mm)	Width (mm)	Height (mm)	Pizza/Carton
13"	386	280	370	5

DD0002

单击下面可查看定价，库存，交付和生命周期等信息

[>>SGMICRO\(圣邦微电子\)](#)