

GENERAL DESCRIPTION

The SGM42600 is a motor driver device with two integrated H-bridges that can run one bipolar stepper motor or two DC brush motors. It can be used in a variety of applications such as printers and battery-powered toys.

Each H-bridge consists of four N-MOSFETs to drive one motor winding. The SGM42600 can supply up to 2A peak or 1.5A RMS output current (with proper heatsinking at $V_{CC} = 5V$ and $T_A = +25^{\circ}C$). At lower V_{CC} voltages, the current capability is decreased slightly.

Internal protection functions are provided for over-current protection (OCP), power supply under-voltage lockout (UVLO), charge pump under-voltage lockout (CPUV) and over-temperature protection (OTP). Fault conditions are indicated by the nFAULT pin.

Sleep mode allows saving power when the device is not driving the motor. The SGM42600 will enter into sleep mode when nSLEEP is low.

The SGM42600 is available in Green TQFN-4x4-16L and TSSOP-16 (Exposed Pad) packages. It operates over an ambient temperature range of $-40^{\circ}C$ to $+125^{\circ}C$.

FEATURES

- **Power Supply Voltage Range: 2.7V to 24V**
- **Dual H-Bridge Motor Driver**
- **Drives Two DC Motors or One Bipolar Stepper Motor**
- **Low On-Resistance (0.41Ω for HS + LS, @ $+25^{\circ}C$)**
- **1.5A RMS Output Current per H-Bridge**
- **2A Peak Current per H-Bridge at $V_{CC} = 5V$, $T_A = +25^{\circ}C$**
- **Active Low Fault Indication Pin (nFAULT)**
- **Available in Green TSSOP-16 (Exposed Pad) and TQFN-4x4-16L Packages**

APPLICATIONS

Printers
Robotics
Cameras
Battery-Powered Toys
Gaming Machines
Office Automation Machines

PACKAGE/ORDERING INFORMATION

MODEL	PACKAGE DESCRIPTION	SPECIFIED TEMPERATURE RANGE	ORDERING NUMBER	PACKAGE MARKING	PACKING OPTION
SGM42600	TSSOP-16 (Exposed Pad)	-40°C to +125°C	SGM42600XPTS16G/TR	SGM42600 XPTS16 XXXXX	Tape and Reel, 4000
	TQFN-4x4-16L	-40°C to +125°C	SGM42600XTQE16G/TR	SGM42600 XTQE16 XXXXX	Tape and Reel, 3000

MARKING INFORMATION

NOTE: XXXXX = Date Code and Vendor Code.

XXXXX

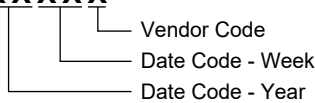

Green (RoHS & HSF): SG Micro Corp defines "Green" to mean Pb-Free (RoHS compatible) and free of halogen substances. If you have additional comments or questions, please contact your SGMICRO representative directly.

ABSOLUTE MAXIMUM RATINGS

- Power Supply Voltage Range, V_{CC} -0.3V to 28V
- Digital Input Pin Voltage Range -0.3V to 6V
- AISEN/BISEN Pin Voltage Range -0.3V to 0.5V
- Peak Motor Drive Output Current Internally limited
- Package Thermal Resistance
- TSSOP-16 (Exposed Pad), θ_{JA} 49°C/W
- TQFN-4x4-16L, θ_{JA} 52°C/W
- Junction Temperature +150°C
- Storage Temperature Range -65°C to +150°C
- Lead Temperature (Soldering, 10s) +260°C
- ESD Susceptibility
- HBM 5000V
- MM 300V
- CDM 1000V

RECOMMENDED OPERATING CONDITIONS

- Power Supply Voltage Range, V_{CC} 2.7V to 24V
- Digital Input Pin Voltage Range -0.3V to 5.5V
- AISEN/BISEN Pin Voltage Range -0.3V to 0.5V
- Continuous DC/RMS Output Current per Bridge 1.5A
- Operating Temperature Range -40°C to +125°C

OVERSTRESS CAUTION

Stresses beyond those listed in Absolute Maximum Ratings may cause permanent damage to the device. Exposure to absolute maximum rating conditions for extended periods may affect reliability. Functional operation of the device at any conditions beyond those indicated in the Recommended Operating Conditions section is not implied.

ESD SENSITIVITY CAUTION

This integrated circuit can be damaged if ESD protections are not considered carefully. SGMICRO recommends that all integrated circuits be handled with appropriate precautions. Failure to observe proper handling and installation procedures can cause damage. ESD damage can range from subtle performance degradation to complete device failure. Precision integrated circuits may be more susceptible to damage because even small parametric changes could cause the device not to meet the published specifications.

DISCLAIMER

SG Micro Corp reserves the right to make any change in circuit design, or specifications without prior notice.

PIN CONFIGURATIONS

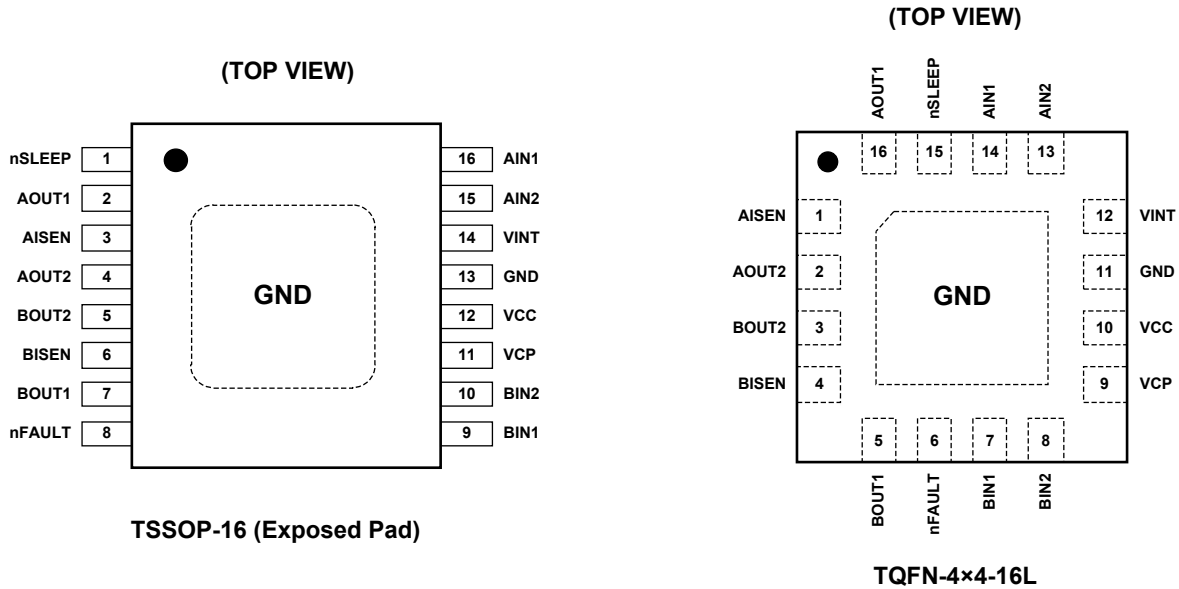

PIN DESCRIPTION

NAME	I/O	FUNCTION
AOUT1	O	Bridge A Output 1.
AOUT2	O	Bridge A Output 2.
BOUT1	O	Bridge B Output 1.
BOUT2	O	Bridge B Output 2.
AIN1	I	Bridge A Input 1. Internal pull-down.
AIN2	I	Bridge A Input 2. Internal pull-down.
BIN1	I	Bridge B Input 1. Internal pull-down.
BIN2	I	Bridge B Input 2. Internal pull-down.
nSLEEP	I	Active-Low Sleep Mode Input. Apply high to enable device, and low to enter in the low-power sleep mode.
nFAULT	OD	Active-Low Fault Flag. Go low when a fault occurs (over-current, power supply under-voltage, charge pump under-voltage, over-temperature).
AISEN	IO	Bridge A I _{SENSE} (GND). Connect through a current sense resistor to GND for bridge A.
BISEN	IO	Bridge B I _{SENSE} (GND). Connect through a current sense resistor to GND for bridge B.
VCP	IO	Charge Pump Output. Connect a 0.01μF, 30V (MIN) ceramic capacitor to VCC pin.
VCC	P	Power Supply Pin. Connect this pin to the motor supply and bypass with a 10μF (MIN) ceramic capacitor to GND.
GND	G	Ground.
VINT	–	Internal Supply Bypass. Bypass to GND with a 2.2μF, 6.3V capacitor.
Exposed Pad	G	GND.

NOTE: I = input; O = output; IO = input or output; OD = open-drain output; G = ground; P = power for the circuit.

ELECTRICAL CHARACTERISTICS

(V_{CC} = 5V, Full = -40°C to +125°C. Typical values are at T_A = +25°C, unless otherwise noted.)

PARAMETER	SYMBOL	CONDITIONS	TEMP	MIN	TYP	MAX	UNITS
Power Supplies							
VCC Operating Supply Voltage	V _{CC}		Full	2.7		24	V
VCC Operating Supply Current	I _{VCC}	xIN1 = 0V, xIN2 = 0V	+25°C		1.7	2.3	mA
VCC Sleep Mode Supply Current	I _{VCCQ}		+25°C		0.7	1.6	μA
VCC Under-Voltage Lockout Voltage	V _{UVLO}		+25°C		2.3	2.4	V
VCC Under-Voltage Lockout Voltage Hysteresis	V _{HYS}		+25°C		100		mV
Logic Level Inputs							
Input Low Voltage	V _{IL}	nSLEEP, V _{CC} = 2.7V to 24V	Full			0.7	V
		All other pins, V _{CC} = 2.7V to 24V	Full			0.7	
Input High Voltage	V _{IH}	nSLEEP, V _{CC} = 2.7V to 24V	Full	2.3			V
		All other pins, V _{CC} = 2.7V to 24V	Full	2.1			
Input Hysteresis	V _{HYS}		+25°C		200		mV
Input Pull-Down Resistance	R _{PD}	nSLEEP	+25°C		520		kΩ
		All except nSLEEP	+25°C		160		
Input Low Current	I _{IL}	V _{IN} = 0V	Full	-1		1	μA
Input High Current	I _{IH}	V _{IN} = 5V, nSLEEP	Full		10	13	μA
		V _{IN} = 5V, all except nSLEEP	Full		32	43	
Input Deglitch Time	t _{DEG}	V _{IN} = 5V	+25°C		460		ns
nFAULT Output (Open-Drain Output)							
Output Low Voltage	V _{OL}	V _{IN} = 2V, I _O = -5mA	+25°C			0.6	V
Output High-Impedance Leakage Current	I _{OH}		+25°C			1	μA
H-Bridge FETs							
HS FET On-Resistance	R _{DS(ON)}	V _{CC} = 5V, I _O = 200mA	+25°C		230		mΩ
		V _{CC} = 5V, I _O = 200mA	Full			500	
		V _{CC} = 2.7V, I _O = 200mA	+25°C		290		
		V _{CC} = 2.7V, I _O = 200mA	Full			590	
LS FET On-Resistance	R _{DS(ON)}	V _{CC} = 5V, I _O = -200mA	+25°C		180		mΩ
		V _{CC} = 5V, I _O = -200mA	Full			440	
		V _{CC} = 2.7V, I _O = -200mA	+25°C		230		
		V _{CC} = 2.7V, I _O = -200mA	Full			490	
Off-State Leakage Current	I _{OFF}	V _{CC} = 24V, V _{OUT} = 0V	+25°C	-4		2	μA
Motor Driver							
Current Control PWM Frequency	f _{PWM}	Internal PWM Frequency	+25°C		45		kHz
Rise Time	t _R	R _L = 16Ω to GND, 10% to 90% V _{CC}	+25°C		80		ns
Fall Time	t _F	R _L = 16Ω to V _{CC} , 90% to 10% V _{CC}	+25°C		50		ns
Propagation Delay INx to OUTx	t _{PROP}		+25°C		1.2		μs
Dead Time ⁽¹⁾	t _{DEAD}		+25°C		550		ns

ELECTRICAL CHARACTERISTICS (continued)(V_{CC} = 5V, Full = -40°C to +125°C. Typical values are at T_A = +25°C, unless otherwise noted.)

PARAMETER	SYMBOL	CONDITIONS	TEMP	MIN	TYP	MAX	UNITS
Protection Circuits							
Over-Current Protection Trip Level	I _{OC} P		+25°C	2.5	3.7		A
OCP Deglitch Time	t _{DE} G		+25°C		4.7		μs
Over-Current Protection Period	t _{OC} P		+25°C		1.4		ms
Thermal Shutdown Temperature	T _{TSD}	Die Temperature			170		°C
Thermal Shutdown Temperature Hysteresis	T _{HYS}				20		°C
Current Control							
xISEN Trip Voltage	V _{TRIP}		+25°C	160	195	230	mV
Current Sense Blanking Time	t _{BLANK}		+25°C		4		μs
nSLEEP Mode							
Start-Up Time	t _{WAKE}	nSLEEP inactive high to H-bridge on	Full			1.3	ms

NOTE: 1. Internal dead time. External implementation is not necessary.

REVISION HISTORY

NOTE: Page numbers for previous revisions may differ from page numbers in the current version.

Changes from Original (APRIL 2017) to REV.A

Changed from product preview to production data.....All

PACKAGE OUTLINE DIMENSIONS

TSSOP-16 (Exposed Pad)

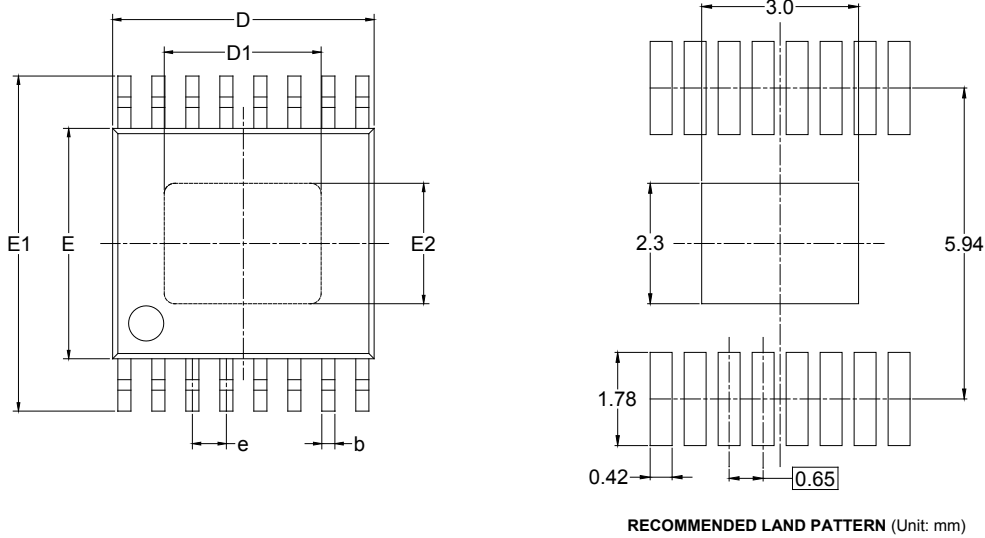

Symbol	Dimensions In Millimeters		Dimensions In Inches	
	MIN	MAX	MIN	MAX
A		1.100		0.043
A1	0.050	0.150	0.002	0.006
A2	0.800	1.000	0.031	0.039
b	0.190	0.300	0.007	0.012
c	0.090	0.200	0.004	0.008
D	4.900	5.100	0.193	0.201
D1	2.900	3.100	0.114	0.122
E	4.300	4.500	0.169	0.177
E1	6.250	6.550	0.246	0.258
E2	2.200	2.400	0.087	0.094
e	0.650 BSC		0.026 BSC	
L	0.500	0.700	0.02	0.028
H	0.25 TYP		0.01 TYP	
θ	1°	7°	1°	7°

PACKAGE OUTLINE DIMENSIONS

TQFN-4x4-16L

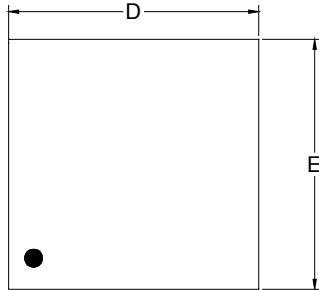

TOP VIEW

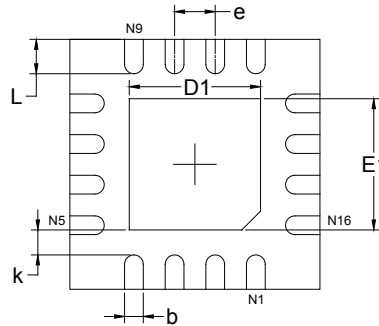

BOTTOM VIEW

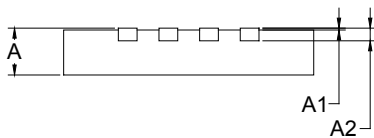

SIDE VIEW

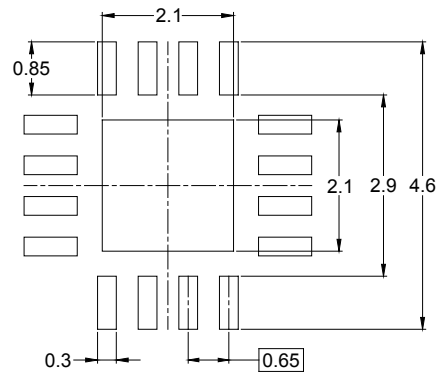

RECOMMENDED LAND PATTERN (Unit: mm)

Symbol	Dimensions In Millimeters		Dimensions In Inches	
	MIN	MAX	MIN	MAX
A	0.700	0.800	0.028	0.031
A1	0.000	0.050	0.000	0.002
A2	0.203 REF		0.008 REF	
D	3.900	4.100	0.154	0.161
D1	2.000	2.200	0.079	0.087
E	3.900	4.100	0.154	0.161
E1	2.000	2.200	0.079	0.087
k	0.200 MIN		0.008 MIN	
b	0.250	0.350	0.010	0.014
e	0.650 TYP		0.026 TYP	
L	0.450	0.650	0.018	0.026

PACKAGE INFORMATION

TAPE AND REEL INFORMATION

REEL DIMENSIONS

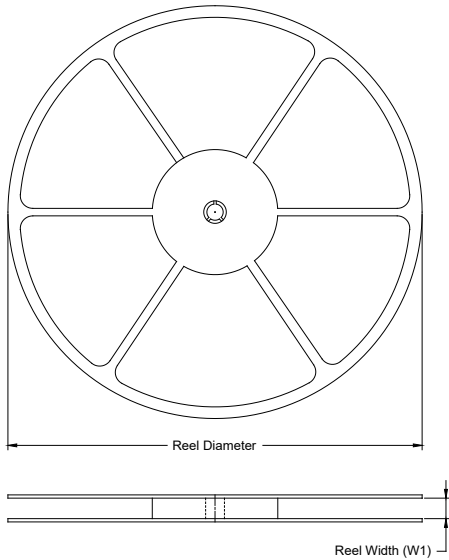

TAPE DIMENSIONS

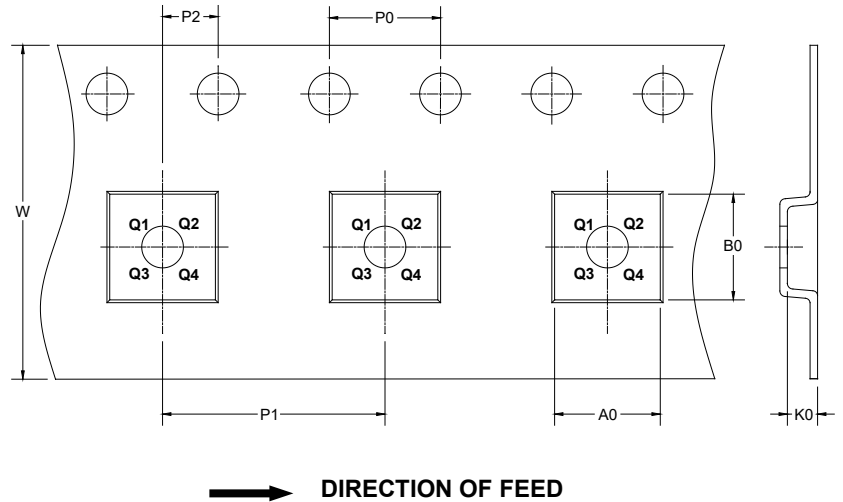

NOTE: The picture is only for reference. Please make the object as the standard.

KEY PARAMETER LIST OF TAPE AND REEL

Package Type	Reel Diameter	Reel Width W1 (mm)	A0 (mm)	B0 (mm)	K0 (mm)	P0 (mm)	P1 (mm)	P2 (mm)	W (mm)	Pin1 Quadrant
TSSOP-16 (Exposed Pad)	13"	12.4	6.90	5.60	1.20	4.0	8.0	2.0	12.0	Q1
TQFN-4x4-16L	13"	12.4	4.30	4.30	1.10	4.0	8.0	2.0	12.0	Q2

DD0001

PACKAGE INFORMATION

CARTON BOX DIMENSIONS



NOTE: The picture is only for reference. Please make the object as the standard.

KEY PARAMETER LIST OF CARTON BOX

Reel Type	Length (mm)	Width (mm)	Height (mm)	Pizza/Carton
13"	386	280	370	5

DD0002

单击下面可查看定价，库存，交付和生命周期等信息

[>>SGMICRO\(圣邦微电子\)](#)