



SGM41524

Compact Switch Li+/Poly Battery Charger

Safe and Reliable Charging

GENERAL DESCRIPTION

The SGM41524 is a compact and efficient Lithium ion (Li+) or Lithium ion polymer (Li+/polymer) battery charger. It can provide power and charge the single cell battery of a system typically found in compact portable device. An internal switching buck converter regulates the supply input for charging the battery and powering the system even if the battery is absent. The converter can also operate as a simple pass-through switch with no switching if the load and input voltages are close.

A typical application circuit is shown in Figure 2. The SGM41524 features resistor programmable constant current and constant voltage charging capability plus a charge limiting timer and operates in compliance with the BAJ/JEITA safety guide. An NTC ($\beta = 3950K$) can be used for battery temperature sensing on top of the internal junction temperature monitoring. The IND status output pin can be connected to LEDs to indicate the operating conditions, such as power input ok (POK), in charging (CHG), VIN over-voltage (POK and CHG alternate blinking) and no power/disabled (OFF). Voltage fold-back on the output is provided to power the system from the input while retaining battery charge and preventing overcharge. Input under-voltage regulation is implemented by reducing the load current such that VIN stays above a minimum when the source is weak. Similarly, the die temperature can be regulated and limited by reducing output power to avoid device or the circuit board being overheated.

These features simplify the system design and ensure safe and reliable operation as well as improved user experience.

The SGM41524 is delivered in a Green TDFN-2×3-8BL package. The device operates in -40°C to +85°C with two thermal regulation options for +55°C or for +115°C.

FEATURES

- **Constant Current, Constant Voltage (CCCV) Charging with Floating Time-Out Timer**
- **Constant Current Pre-charge**
- **Maximum 2.3A Charging for 4.2V to 4.5V Battery**
- **1.34MHz Switching Frequency**
- **Programmable Charge Voltage and Current**
- **4.15V Input Voltage Regulation**
- **Output Voltage Fold-Back Charge Retaining**
- **Thermal Regulation Options**
 - ♦ **SGM41524: +115°C**
 - ♦ **SGM41524C: +55°C**
- **Typical Peak Efficiency of 92% at 1.5A, $V_{IN} = 5V$**
- **-40°C to +85°C Operating Temperature Range**
- **Available in a Green TDFN-2×3-8BL Package**

APPLICATIONS

Powering and Charge Control of Systems with 500mAh to 6000mAh Li+/Polymer Batteries

PACKAGE/ORDERING INFORMATION

MODEL	PACKAGE DESCRIPTION	SPECIFIED TEMPERATURE RANGE	ORDERING NUMBER	PACKAGE MARKING	PACKING OPTION
SGM41524	TDFN-2×3-8BL	-40°C to +85°C	SGM41524YTDC8G/TR	CBA XXXX	Tape and Reel, 3000
	TDFN-2×3-8BL	-40°C to +85°C	SGM41524CYTDC8G/TR	CG1 XXXX	Tape and Reel, 3000

MARKING INFORMATION

NOTE: XXXX = Date Code and Trace Code.

YYY — Serial Number

X XXX

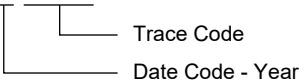

Green (RoHS & HSF): SG Micro Corp defines "Green" to mean Pb-Free (RoHS compatible) and free of halogen substances. If you have additional comments or questions, please contact your SGMICRO representative directly.

ABSOLUTE MAXIMUM RATINGS

Voltage Range (with Respect to GND)

- V_{IN} (V_{BAT} = 4V)..... 6V
- V_{BAT} (V_{IN} Open) 6V
- CC, CV, IND, NTC, SW..... -0.3V to 6V
- Package Thermal Resistance
- TDFN-2×3-8BL, θ_{JA}..... 90°C/W
- Junction Temperature.....+150°C
- Storage Temperature Range -65°C to +150°C
- Lead Temperature (Soldering, 10s).....+260°C
- ESD Susceptibility
- HBM, Any Pin to Ground and Power 4000V
- CDM 1000V
- Surge Test
- Input Surge Discharge ⁽¹⁾ 11V
- Input Over-Voltage Clamp8V or 50mA, 24 hours

NOTE:

1. Peak current in IEC61000-4-5 1.2µs/50µs 2Ω waveform.

RECOMMENDED OPERATING CONDITIONS

- Supply Voltage Range3.5V to 5.5V
- CC, CV, IND, NTC -0.3V to 5.5V
- Charge Current Setting Range0.3A to 2.3A
- Operating Junction Temperature Range -40°C to +125°C
- Environmental Temperature Range -40°C to +85°C

OVERSTRESS CAUTION

Stresses beyond those listed in Absolute Maximum Ratings may cause permanent damage to the device. Exposure to absolute maximum rating conditions for extended periods may affect reliability. Functional operation of the device at any conditions beyond those indicated in the Recommended Operating Conditions section is not implied.

ESD SENSITIVITY CAUTION

This integrated circuit can be damaged if ESD protections are not considered carefully. SGMICRO recommends that all integrated circuits be handled with appropriate precautions. Failure to observe proper handling and installation procedures can cause damage. ESD damage can range from subtle performance degradation to complete device failure. Precision integrated circuits may be more susceptible to damage because even small parametric changes could cause the device not to meet the published specifications.

DISCLAIMER

SG Micro Corp reserves the right to make any change in circuit design, or specifications without prior notice.

PIN CONFIGURATION

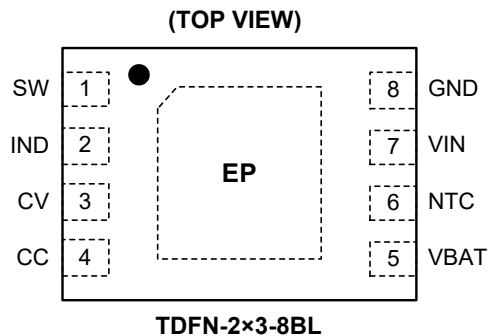

PIN DESCRIPTION

PIN	NAME	TYPE	FUNCTION
1	SW	O	Buck Converter Switching Node. Connect to the output inductor.
2	IND	O	Status Indication Output. It can source or sink constant current when powered (charging or not charging). It can only sink current if no power is applied.
3	CV	I	Charge Voltage Programming Input Pin. Connect a resistor between this pin and ground to select one of the seven charging voltages.
4	CC	I	Charge Current Programming/Charge-Inhibit Input Pin. Connect a resistor between this pin and GND to program the constant charge current I_{CC} , ($R_{CCSET} = K/I_{CC}$). Pull up this pin to a voltage higher than V_{INH} to inhibit and stop charging.
5	VBAT	I	Battery Voltage Sense Input.
6	NTC	I	NTC Temperature Sensing Input. Connect to an NTC thermistor ($\beta = 3950K$) with other end grounded and biased to V_{IN} by a $1.5 \times R_{NTC25^\circ C}$ resistor. Ground this pin if NTC is not used.
7	VIN	P	Power Input Pin.
8	GND	G	Ground Reference Pin.
Exposed Pad	EP	IC	Exposed Pad. Thermal pad is internally grounded and must be connected to the PCB GND plane.

NOTE:

I = Input, O = Output, G = Ground, P = Power for the Circuit, IC = Internal Connection.

ELECTRICAL CHARACTERISTICS

(V_{VIN} = 5V, V_{VBAT} = 3.8V, Full = -40°C to +85°C, typical values are at T_J = +25°C, unless otherwise noted.)

PARAMETERS	SYMBOL	CONDITIONS	TEMP	MIN	TYP	MAX	UNITS
Over-Voltage Protection Threshold	V _{OVp}	VBAT open, V _{VIN} = 5V to 6V	+25°C	5.51	5.67	5.84	V
			Full	5.49	5.67	5.85	
Minimum Input Operation Voltage	V _{CHGm}	VBAT open, V _{VIN} = 5V to 4V	+25°C	3.90	4.04	4.17	V
			Full	3.85	4.04	4.20	
VIN Supply Current	I _Q	IND open, fold-back mode, R _{CV} = 1kΩ, set V _{VBAT} = 4.17V, no switching	+25°C		15	20	μA
			Full		15	21	
Leakage Current into the VBAT ⁽¹⁾	I _{LKGFLD}	Fold-back mode, R _{CV} = 1kΩ, set V _{VBAT} = 4.17V, no switching	+25°C		0.1	1.4	μA
			Full		0.1	1.5	
	I _{LKG}	VIN open, V _{VBAT} = 3V to 4.5V	+25°C		0.1	1.4	μA
			Full		0.1	1.5	
Charge Loop							
Charge Output Regulation Voltage	V _{CHG}	CV pin connected to GND	+25°C	4.175	4.20	4.225	V
			Full	4.145	4.20	4.255	
Charge Voltage Step	V _{STEP}		Full		50		mV
The Minimum Voltage Drop between VIN and VBAT Required for Switch Charging	V _{DROPM}	LDO charge mode, input voltage is greater than V _{CHGm}	Full	2	20	40	mV
	V _{DROPM}	Switch charge mode, input voltage is greater than V _{CHGm}	Full	120	170	230	mV
Charge Voltage Fold-Back when NTC Temperature is out of 10°C to 45°C Range	V _{DEG}	Compare with V _{CHG} in 10°C to 45°C NTC temperature range	Full		50		mV
Charge Current Decrease at NTC Temperature Regulation ⁽¹⁾	I _{DEG}	As percentage of I _{CC} in 10°C to 45°C NTC temperature range	+25°C	28	30	32	%
			Full	27	30	33	
5°C Threshold ⁽¹⁾	DT1	As percentage of V _{VIN}	+25°C	62	63	65	%
			Full	61	63	66	
10°C Threshold ⁽¹⁾	DT2	As percentage of V _{VIN}	+25°C	56	58	59	%
			Full	55	58	60	
45°C Threshold ⁽¹⁾	DT3	As percentage of V _{VIN}	+25°C	21	23	24	%
			Full	20	23	25	
55°C Threshold ⁽¹⁾	DT4	As percentage of V _{VIN}	+25°C	16	17	18	%
			Full	15	17	19	
Floating Charge Timer Start Threshold	V _{FLT}	As percentage of V _{CHG}	+25°C	96.5	98.0	99.4	%
			Full	96.4	98.0	99.5	
Fold-Back Retaining Output Voltage	FR	As percentage of V _{CHG}	+25°C	96.8	97.1	97.5	%
			Full	96.7	97.1	97.7	
Recharge Threshold	V _{RR}	As percentage of V _{CHG}	+25°C	94.0	95.5	97.0	%
			Full	93.9	95.5	97.1	
Battery Precondition Charge Current	I _{PRE}	V _{VIN} = 5V, V _{VBAT} < 60% × V _{CHG}	+25°C	67	97	128	mA
			Full	65	97	130	
Battery Precondition Threshold Voltage	V _{PRE}	As percentage of V _{CHG}	+25°C	57	60	63	%
			Full	56	60	65	

NOTE: 1. Parameters guaranteed by product characterization.

ELECTRICAL CHARACTERISTICS (continued)(V_{VIN} = 5V, V_{VBAT} = 3.8V, Full = -40°C to +85°C, typical values are at T_J = +25°C, unless otherwise noted.)

PARAMETERS	SYMBOL	CONDITIONS	TEMP	MIN	TYP	MAX	UNITS
Load Pre-charge Current	I _{LOADPRECHG}	When power-up at V _{VBAT} < 60% × V _{CHG}	Full		300		mA
Load Pre-charge Period	t _{LOADPRECHG}		+25°C	4.23	5.00	5.77	ms
			Full	4.05	5.00	5.83	
Charge Current Setting Ratio	K	R _{CC} = 10kΩ, K = I _{CC} × R _{CCSET}	+25°C	9450	10000	10500	V
			Full	9150	10000	10800	
Charge Inhibition Voltage Threshold	V _{INH}	Voltage forcing on the CC pin to inhibit charging			1.5		V
Fast Charge Current	I _{CC}	R _{CC} = 10kΩ, V _{VBAT} = 3.8V, V _{VIN} = 5V	+25°C	0.945	1	1.050	A
			Full	0.915	1	1.080	
Charge Termination Current Threshold	I _{RES}		+25°C	95	140	175	mA
			Full	85	140	190	
Floating Charge Termination Time	t _{FCOT}		+25°C	77	92	107	min
			Full	74	92	108	
Input Voltage Regulation Threshold	V _{INREG}	V _{VBAT} = 3.8V, V _{VIN} for making charge current to 0	+25°C	4.00	4.15	4.30	V
			Full	3.98	4.15	4.32	
Thermal Regulation Threshold ⁽¹⁾	T _{OTR}	SGM41524C			55		°C
	T _{OTR}	SGM41524			115		°C
Thermal Shutdown Temperature	T _{SHUT}	Temperature increasing			155		°C
Thermal Shutdown Hysteresis	T _{SHUT_HYST}				20		°C
BAT Voltage Monitoring Period before Turning into Fold-Back Switch Operation	t _{MON}		+25°C	162	192	222	ms
			Full	155	192	224	
High-side Switch MOSFET On-Resistance between VIN and SW	R _{DS(ON)-H}		+25°C		140	170	mΩ
			Full		140	200	
Low-side Switch MOSFET On-Resistance between SW and GND	R _{DS(ON)-L}		+25°C		120	150	mΩ
			Full		120	180	
Peak Current Limit	I _{PEAK}		Full		3.2		A
PWM Switching Frequency	f _S		+25°C	1.13	1.34	1.55	MHz
			Full	1.08	1.34	1.56	
Indication Driving							
IND Sink Current ⁽¹⁾	I _{INDSNK}	V _{VIN} = 5V	+25°C	0.7	1.3	1.9	mA
			Full	0.4	1.3	2.5	
IND Source Current ⁽¹⁾	I _{INDSRC}	V _{VIN} = 5V	+25°C	0.6	1.3	2.0	mA
			Full	0.4	1.3	2.5	
IND Blink Period	t _{BLINK}	Input OVP state	+25°C	162	192	222	ms
			Full	155	192	224	

NOTE: 1. Parameters guaranteed by product characterization.

TYPICAL PERFORMANCE CHARACTERISTICS

$V_{IN} = 5V$, $V_{BAT} = 3.8V$, $T_J = +25^{\circ}C$, unless otherwise noted.

DCM Mode Switch Waveform

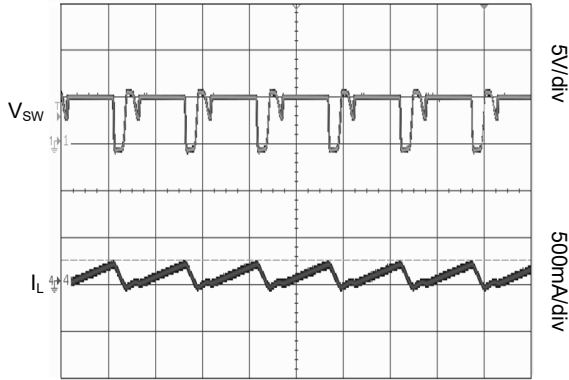

Time (500ns/div)

CCM Mode Switch Waveform

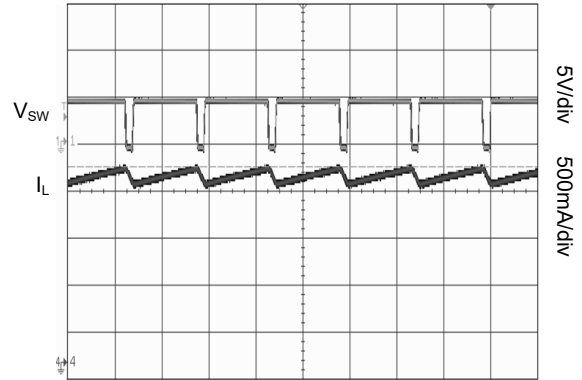

Time (500ns/div)

Start-up Charge by V_{IN} , with 3.7V Battery at BAT

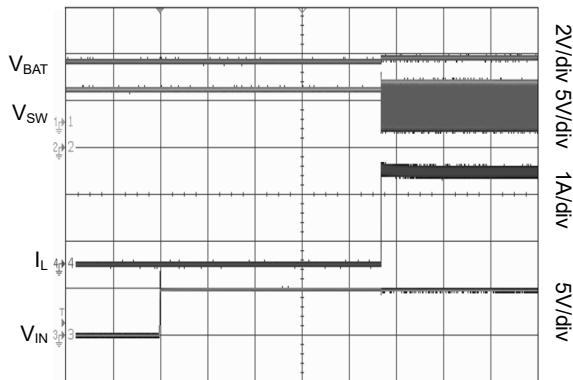

Time (5ms/div)

Start-up Charge by V_{IN} , with 10Ω Resistor at BAT

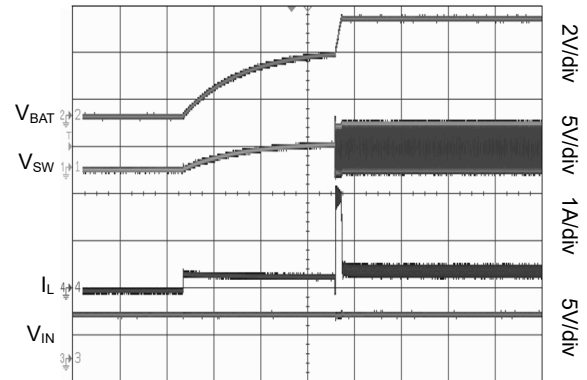

Time (1ms/div)

Forcing CC = 2V to Disable Charge

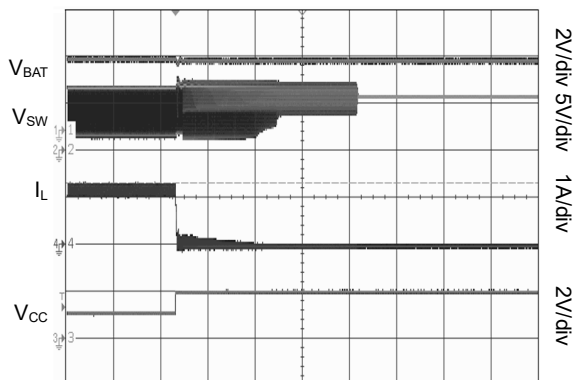

Time (50μs/div)

Recovery Charge by Release CC

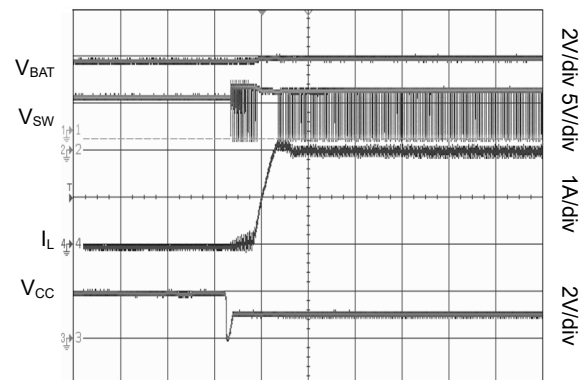

Time (20μs/div)

TYPICAL PERFORMANCE CHARACTERISTICS (continued)

$V_{VIN} = 5V$, $V_{VBAT} = 3.8V$, $T_J = +25^\circ C$, unless otherwise noted.

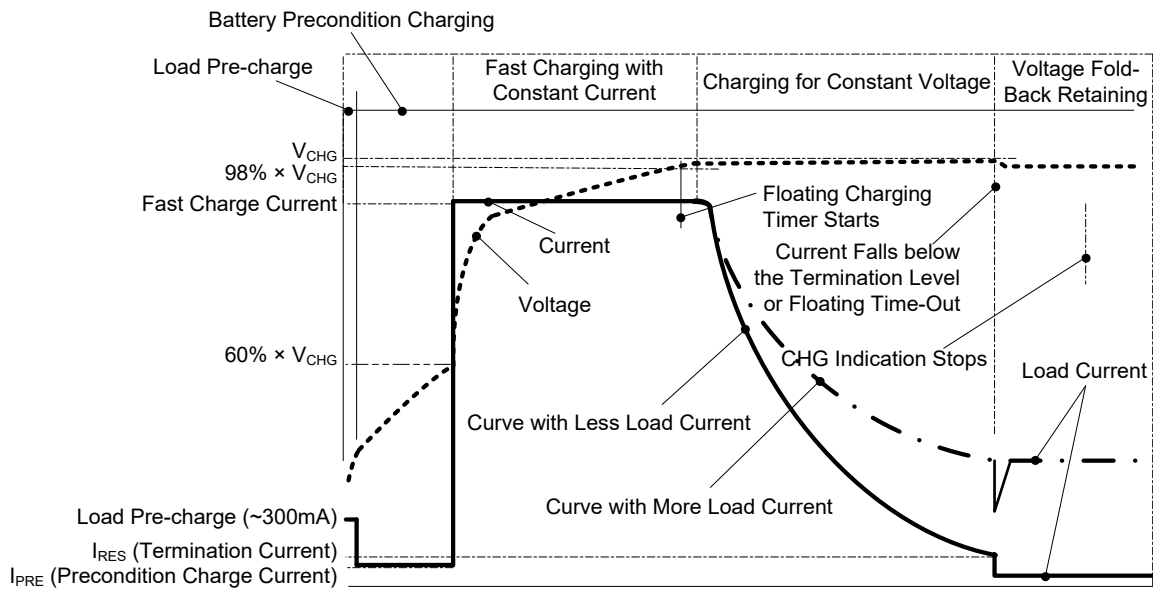
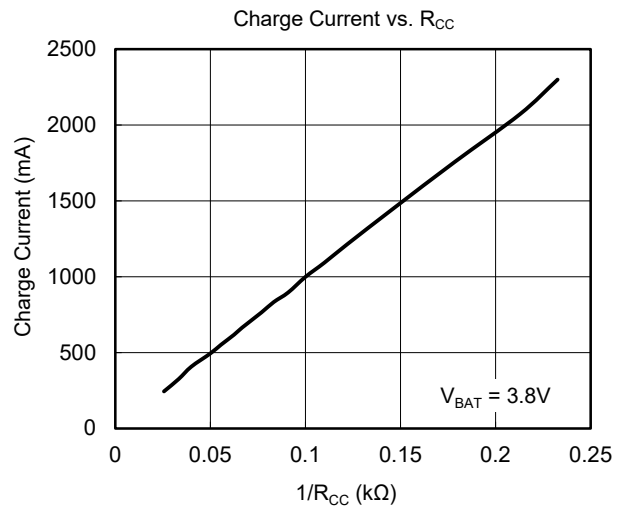
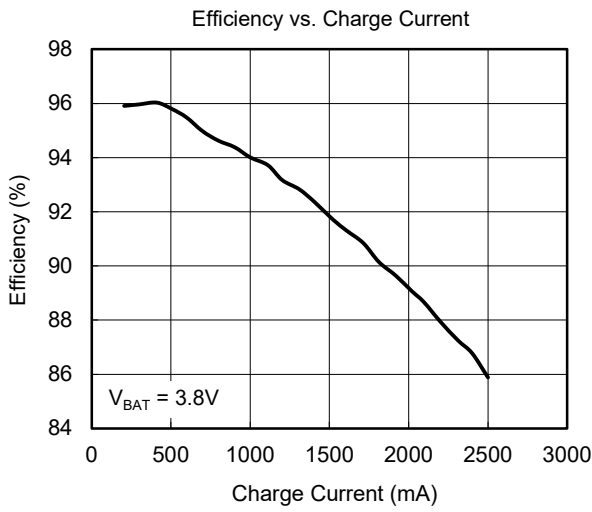

Figure 1. Charging Voltage/Current Profile

Compact Switch Li+/Poly Battery Charger Safe and Reliable Charging

SGM41524

TYPICAL APPLICATION

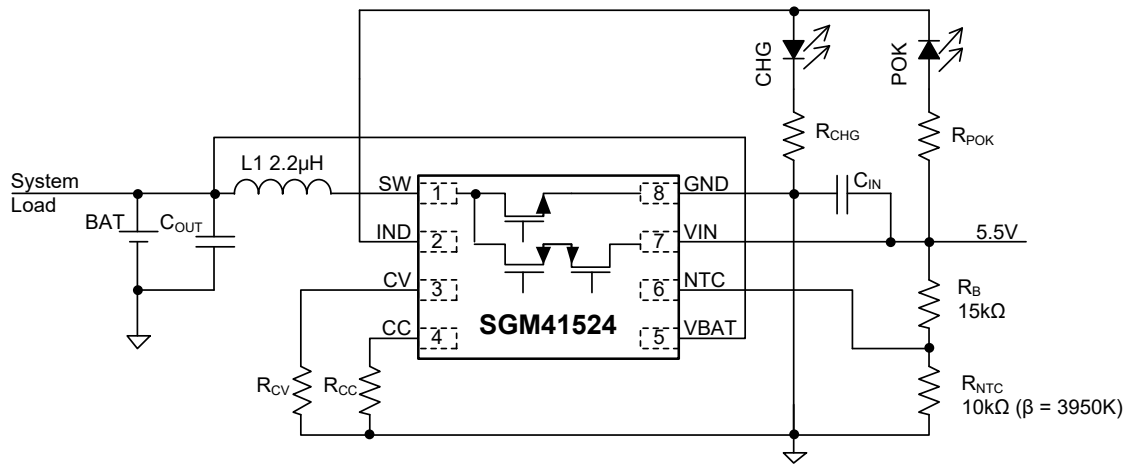

Figure 2. Typical Application Circuit

FUNCTIONAL BLOCK DIAGRAM

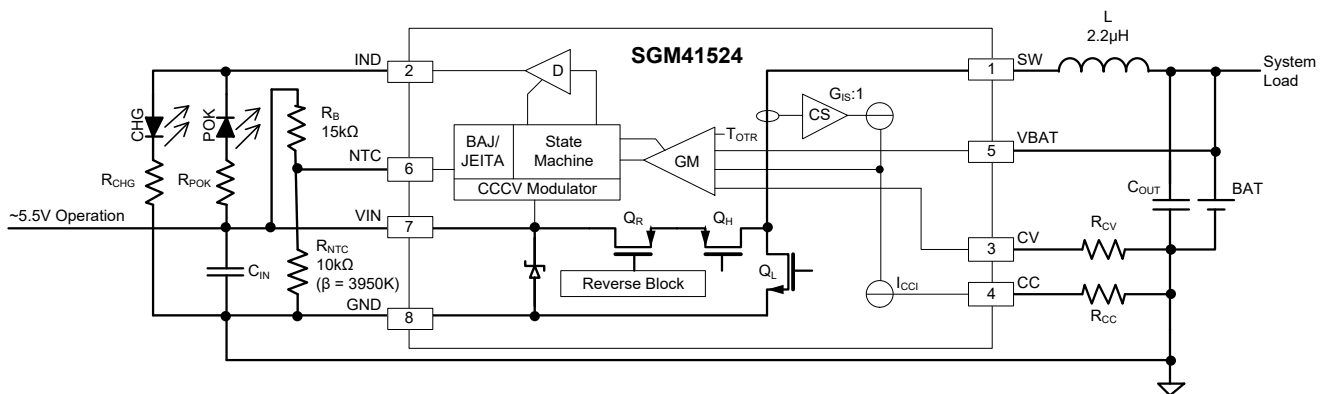

Figure 3. Block Diagram

ESSENTIAL SEQUENCE

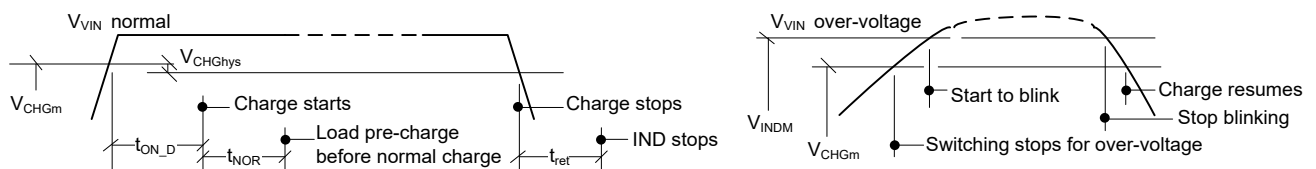

Figure 4. Essential On/Off Timing

FUNCTION DESCRIPTION AND APPLICATION

The SGM41524 is a general purpose stand-alone switch mode charger device designed for powering systems using Li+/poly rechargeable batteries. Several features are provided including charge voltage and current programming and status indication. Input voltage and die temperature are constantly monitored to prevent output power failure. If the input supply voltage drops too low, the device reduces the output power to reduce loading on the input and prevent further drop and power failure. Similarly, if the junction is overheated by heavy load, the output power is reduced to prevent thermal shutdown and system power failure. It is also capable for various charging modes like constant-current, constant-voltage, constant-current pre-charging, and trickle charging (when input source is weak).

This device does not have a separate battery switch to connect or disconnect the battery from the system (load). However, it uses voltage fold-back retaining for battery safety and lifetime extension when the battery is fully charged and input power is present. With this method, battery energy loss is lower because there is no switch in the discharge path. The only disadvantage is that if the battery voltage is excessively low, then start the system instantly is not possible because charge path cannot be separated and it may take a few minutes to charge the battery and reach to an adequate voltage level to start the load system.

Power-Up with Low/No Battery

If the battery is not attached or its voltage is less than 60% of V_{CHG} ($V_{VBAT} < 0.6V_{CHG}$), the device feeds the VBAT with a current limited to less than 300mA for about 5ms to pre-charge the battery and system load before it goes into battery preconditioning state. This pre-charge period can increase the voltage of a 500 μ F capacitor (between VBAT and GND) for up to 3V before the device starts to deliver the lower preconditioning current (almost 97mA).

If the load is started before fast charge phase, the supply capacity will be limited to the precondition charge current for a relatively long time. The initial 5ms pre-charge period can quickly bring the device to the fast charge or even fold-back phase when there is no battery attached and provide enough power for the system operation in a short time.

Charging Profile and Fold-Back Retaining

The charging profile is shown in Figure 1. When the battery voltage is less than $0.6V_{CHG}$, the output current is regulated to a low and safe preconditioning level (I_{PRE}). On the other hand when the input supply is present and charge is complete, the output goes to the safe voltage fold-back mode for powering the load. In this mode, the output current is limited to less than peak switch current limit (I_{PEAK}) and not to the programmed charge current limit. Figure 5 shows the load transient response of the evaluation board circuit whose charge current is programmed for less than the load current.

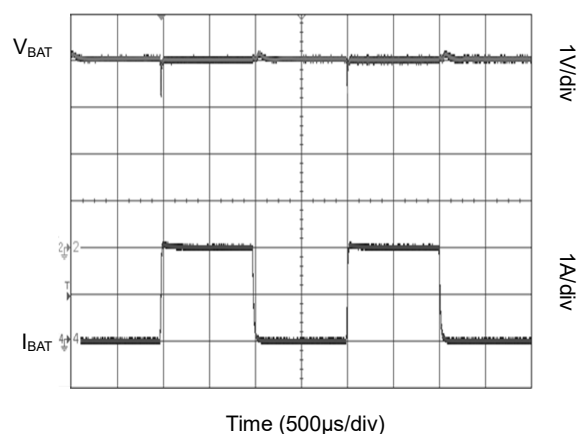

Figure 5. Load Transient Response in Fold-Back Supply

The input voltage is monitored during charging. If the source is weak and cannot maintain its voltage under heavy load, the charging current is reduced to avoid system power collapse due to input voltage drop.

The charge is considered full if the battery voltage exceeds the floating voltage V_{FLT} and the charge current drops below the end of charge current (I_{RES}) or if the floating charge timer runs out of time (t_{FCOT}).

When the full charge status is detected, the output will drop to the fold-back voltage specified by fold-back retaining output voltage ratio (FR ratio is typically 97.1% of V_{CHG} as specified in the EC table) and converter continues to work but indicator shows "not charging". If the battery voltage is higher than fold-back level, the switching will stop. VBAT is monitored periodically and if it drops below that level the buck converter starts to operate and regulate the output to the fold-back level. The full charge state is continued until the input power is recycled or if the battery voltage drops below the recharge voltage level (V_{RR}).

FUNCTION DESCRIPTION AND APPLICATION (continued)

If the voltage drop between the input and output (V_{DROP}) is small and less than V_{DROPm} , the device goes into forward diode state and stops switching. Switching is resumed if the V_{DROP} exceeds V_{DROPm} level. The CHG indication will turn off if the time of $V_{DROP} < V_{DROPm}$ is longer than the retaining time (t_{RET}).

Charge Current Programming and Turn Off

Charge current is programmed by R_{CCSET} resistance by $R_{CCSET} = K/I_{CC}$ where the K is charge current setting ratio which is typically 10000V as specified in the EC table.

Pulling the CC pin to a voltage level higher than V_{INH} turns the device off (disabled). When this pin is released the device resumes the status before being inhibited.

Charge Voltage Programming

Charging voltage can be programmed in one of the 7 preset values by setting a voltage on CV pin. A 50 μ A current source is internally connected to CV pin. Programming can be done by directly applying a voltage to the CV pin, or by connecting a resistor to GND that results in the same voltage as shown in Table 1.

Table 1. Conditions for Selecting a Charging Voltage

Charging Voltage (V)	Forcing Voltage (V)	Separation Thresholds (V)	Grounding Resistance (k Ω)
4.2	GND	< 0.4	Short
4.25	0.6	0.4 to 0.8	12
4.3	1.0	0.8 to 1.2	20
4.35	1.4	1.2 to 1.6	28
4.4	1.8	1.6 to 2.0	36
4.45	2.2	2.0 to 2.4	44
4.5	Open	> 2.4	Open

NOTE: Sourcing current out of the CV is 50 μ A typically.

BAJ/JEITA Charging Extending and Safety

This device implements the battery temperature related charging control in compliance with the BAJ/JEITA guide on safe use of secondary Lithium ion batteries. An NTC ($\beta = 3950K$) can be used as shown in Figure 2 (or Figure 3) for battery temperature sensing.

As specified in Table 2, the charging voltage and current are reduced when the sensed battery temperature is out of the preferred charging range (10°C to 45°C). When the temperature is too high (above

55°C), the device stops charging and when it is too low (less than 5°C), only the small precondition current is charged.

Table 2. Temperature Related Charging Control

Temperature Range	Charging Voltage	Charging Current
Low range, < 5°C.	$V_{CHG} - 50mV$	I_{RES}
Low charging range, 5°C to 10°C	$V_{CHG} - 50mV$	70% I_{CC}
Recommended charging range, 10°C to 45°C	V_{CHG}	I_{CC}
High charging range, 45°C to 55°C	$V_{CHG} - 50mV$	70% I_{CC}
High range, > 55°C	—	0

NOTE: The V_{CHG} and the I_{CC} (charging voltage and current) are selected in accordance with the battery's specification.

If NTC feature is not used, connect the NTC pin to ground. The device checks for grounded NTC pin once during the start-up when the input voltage is exceeding 2.7V.

Indication and Status Reading

The IND output can have 4 states to show different conditions: (1) Low (sink current) to indicate the input power is available (or not charging); (2) High (source current) to indicate the device is in charging; (3) Hi-Z (open) for indicating no power is available (when $V_{IN} < V_{CHGm}$) or when it is turned off by pulling the CC pin voltage up; and (4) blinking or alternatingly Low and High (sinking and sourcing current) if an input over-voltage occurs. IND voltage can be used as a signal for the host or other circuit for status detection.

Note that in the high impedance state (Hi-Z), the POK LED and CHG LED are forward biased by the input voltage (all in series) and they can turn on depending on the drive current determined by the LED forward voltages and series resistances.

Input Voltage Regulation and Thermal Regulation

To prevent power shutdown, the output current is gradually reduced if V_{IN} drops close to the minimum (V_{CHGm}). Output current eventually reaches to zero when V_{IN} falls to V_{CHGm} level. Similarly, if the junction temperature increases close to its maximum (T_{OTR}), the output current is progressively reduced and will reach to zero when the temperature reaches to T_{OTR} .

FUNCTION DESCRIPTION AND APPLICATION (continued)

Component Selection and Layout

Inductor Selection

Small inductors and capacitors can be chosen thanks to the high operating switching frequency of the 1.34MHz. Select an inductor with a saturation current a little bit higher than the charging current (I_{CHG}) plus half the ripple current peak to peak magnitude (I_{RIPPLE}):

$$I_{SAT} \geq I_{CHG} + (1/2) I_{RIPPLE} \quad (1)$$

The inductor ripple current depends on the input voltage (V_{VBUS}), the duty cycle ($D = V_{VBAT}/V_{VBUS}$), the switching frequency (f_s) and the inductance (L). In CCM (e.g. full load):

$$I_{RIPPLE} = \frac{V_{VBUS} \times D \times (1-D)}{f_s \times L} \quad (2)$$

The maximum inductor ripple current occurs when the duty cycle (D) is 0.5 or near. Typically, the inductor ripple is designed in the range between 20% and 40% of the maximum charging current as a trade-off between inductor size and efficiency. Smaller inductor results in higher ripple (AC) current flowing into the capacitor and switches and can reduce efficiency.

Input Capacitor

Choose the input capacitance with enough RMS current rating to decouple input switching AC currents away from input. Low ESR ceramic capacitor such as X5R or X7R is preferred for input decoupling. Typically, 10 μ F capacitance is suitable for 1A to 2A charging current. Keep the capacitor(s) close to VIN and GND pins to minimize the parasitic inductance in the input ripple current circulation path. In the worst-case, the RMS of the ripple current is half of the DC charging current (I_{CHG}) when duty cycle is $D = 50\%$. If the converter does not operate at 50% duty cycle, then the worst-case occurs when duty cycle is closest to 50%. The input RMS current (I_{CIN}) can be estimated by Equation 3.

$$I_{CIN} = I_{CHG} \times \sqrt{D \times (1-D)} \quad (3)$$

Output Capacitor

A few factors must be considered to design the output capacitance. First, the SGM41524 has the internal loop compensation for the buck converter that is optimized for ceramic output capacitance larger than 10 μ F. The output capacitor (C_{OUT}) circulates the output ripple current and prevents it from going into the battery. Having AC current in the battery results in extra heating and lower lifetime.

Equation 4 gives the output capacitor RMS current I_{COUT} when no battery is attached.

$$I_{COUT} = \frac{I_{RIPPLE}}{2 \times \sqrt{3}} \approx 0.29 \times I_{RIPPLE} \quad (4)$$

The RMS ripple voltage in worst case is calculated as:

$$V_{RIPPLE} = \frac{I_{RIPPLE}}{2 \times \pi \times f_s \times C_{OUT}} \quad (5)$$

The capacitance should be selected large enough for meeting the system requirement for acceptable V_{RIPPLE} . In the system design, operation with no battery must be considered carefully. Typically, the presence of the battery helps in filtering of the sags and ripples and provides peak energy demands when load surges occur. When the battery is absent, a relatively large capacitor is needed to have proper performance.

Besides the V_{RIPPLE} requirement, the load starting inrush current is another factor to consider for output capacitor selection. If at the beginning the device turns into fold-back, the converter does not start switching as the output capacitor holds the voltage higher than the fold-back retaining voltage. VBAT voltage is monitored periodically and as long as it is above fold-back voltage, it is only the output capacitor that powers the system in the absence of the battery. The capacitance should be large enough to maintain the VBAT voltage and prevent dropping below minimum system requirement before the switching fold-back mode supply operation starts. The capacitance for fulfilling this requirement is highly dependent on how the load starts, including its timing, start current and acceptable voltage drop. Verification with a prototype is recommended if operation without a battery is considered.

Layout Guide

1. Place VIN capacitor close to the VIN pin and GND pin.
2. Place the inductor terminal close to the SW pin and minimize the copper area of switching node trace. Do not use multiple layers for this connection.
3. Minimize the return loop area and ripple current path length through the inductor and the output capacitor(s) to the device GND pin.
4. Use copper plane for power GND and place multiple via between top and bottom GND plane for better heat dissipation and noise immunity.

FUNCTION DESCRIPTION AND APPLICATION (continued)

PCB Layout Example

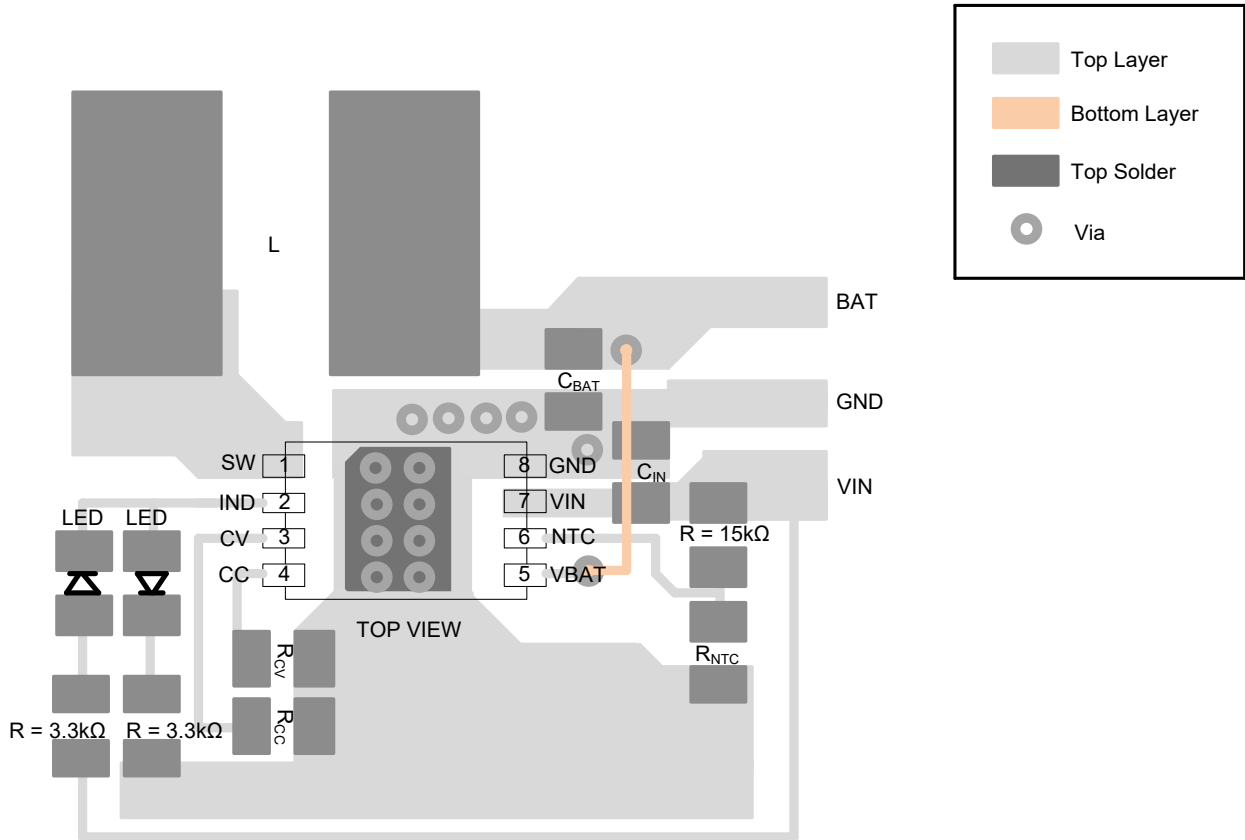

Figure 6. Typical PCB Layout

FUNCTION DESCRIPTION AND APPLICATION (continued)

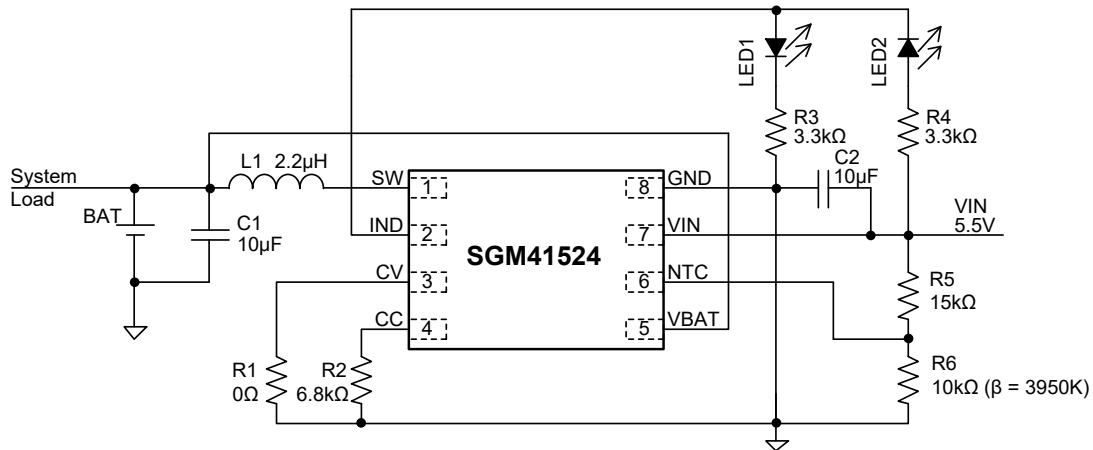

Figure 7. Typical Application Circuit, Programmed for Charge Current of $I_{CC} = 1.47A$, and Voltage of $V_{CHG} = 4.20V$

Table 3. Bill of Materials for Typical Application Circuit

Designator	Quantity	Description	Size	Maker	Part Number
U1	1	Switch Li+/Poly Battery Charger	TDFN-2x3-8BL	SGMICRO	SGM41524/SGM41524C
L1	1	Ind, 2.2µH, Irms = 4.3A, Isat = 6.1A, DCR = 40mΩ	4.0*4.0*2.0mm	Sunlord	WPN4020H2R2MT
C1, C2	2	Cap, Cerm, 10µF, 10V, X5R	0603	SAMSUNG	
R1	1	Res, 0Ω, 1%	0603	UniOhm	
R2	1	Res, 6.8kΩ, 1%	0603	UniOhm	
R3, R4	2	Res, 3.3kΩ, 5%	0603	UniOhm	
R5	1	Res, 15kΩ, 1%	0603	UniOhm	
R6	1	NTC, 10kΩ, 1%, β = 3950K	0603	Sunlord	SDNT1608X103F3950FTF
LED1, LED2	2	Chip Light Emitting Diode, Blue	0603	Nationstar	FC-DA1608BK-470H10

REVISION HISTORY

NOTE: Page numbers for previous revisions may differ from page numbers in the current version.

NOVEMBER 2020 – REV.A to REV.A.1	Page
Updated Absolute Maximum Ratings and Recommended Operating Conditions sections	2
Changes from Original (DECEMBER 2019) to REV.A	Page
Changed from product preview to production data	All

PACKAGE OUTLINE DIMENSIONS

TDFN-2x3-8BL

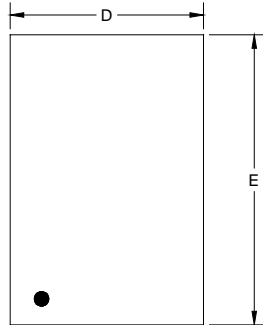

TOP VIEW

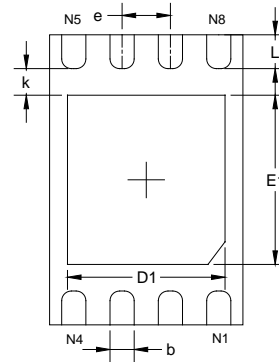

BOTTOM VIEW

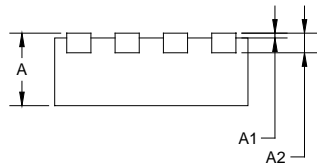

SIDE VIEW

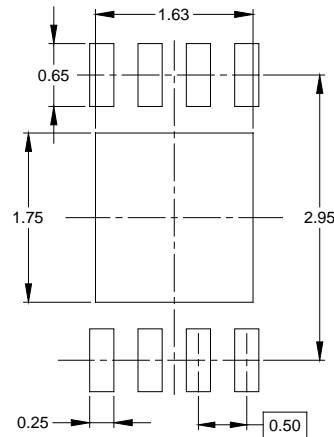

RECOMMENDED LAND PATTERN (Unit: mm)

Symbol	Dimensions In Millimeters		Dimensions In Inches	
	MIN	MAX	MIN	MAX
A	0.700	0.800	0.028	0.031
A1	0.000	0.050	0.000	0.002
A2	0.203 REF		0.008 REF	
D	1.950	2.050	0.077	0.081
D1	1.530	1.730	0.060	0.068
E	2.950	3.050	0.116	0.120
E1	1.650	1.850	0.065	0.073
b	0.200	0.300	0.008	0.012
e	0.500 BSC		0.020 BSC	
k	0.250 REF		0.010 REF	
L	0.300	0.450	0.012	0.018

PACKAGE INFORMATION

TAPE AND REEL INFORMATION

REEL DIMENSIONS

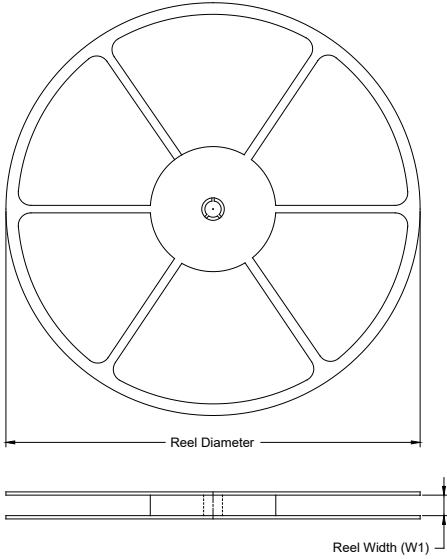

TAPE DIMENSIONS



NOTE: The picture is only for reference. Please make the object as the standard.

KEY PARAMETER LIST OF TAPE AND REEL

Package Type	Reel Diameter	Reel Width W1 (mm)	A0 (mm)	B0 (mm)	K0 (mm)	P0 (mm)	P1 (mm)	P2 (mm)	W (mm)	Pin1 Quadrant
TDFN-2×3-8BL	7"	9.5	2.30	3.30	1.10	4.0	4.0	2.0	8.0	Q2

000001

PACKAGE INFORMATION

CARTON BOX DIMENSIONS



NOTE: The picture is only for reference. Please make the object as the standard.

KEY PARAMETER LIST OF CARTON BOX

Reel Type	Length (mm)	Width (mm)	Height (mm)	Pizza/Carton
7" (Option)	368	227	224	8
7"	442	410	224	18

DD0002

单击下面可查看定价，库存，交付和生命周期等信息

[>>SGMICRO\(圣邦微电子\)](#)