

GENERAL DESCRIPTION

The SGM9122 is a dual rail-to-rail video driver with 6dB gain which can operate from 3.0V to 5.5V single power supply, while consuming an ultra-low 5.8mA quiescent current. The device is optimized for low power, battery-operated applications.

SGM9122 has clamp function and SAG correction can reduce output capacitance.

The device allows DC- or AC-coupled output. SGM9122 can be DC-coupled or AC-coupled with input video signal to eliminate out-of-band noise, such as the output stage of DAC.

The SGM9122 is available in a Green TSSOP-8 and WSOP-8 packages. It operates over an ambient temperature range of -40°C to +85°C.

FEATURES

- **Supply Voltage Range: 3.0V to 5.5V**
- **Dual-Channel Video Drivers**
- **15MHz Frequency**
- **Internal Gain: 6dB**
- **SAG Correction**
- **Drive Dual Video Loads**
- **Quiescent Current: 5.8mA Typical (Dual)**
- **AC- or DC-Coupled Inputs**
- **AC- or DC-Coupled Outputs**
- **Rail-to-Rail Output**
- **-40°C to +85°C Operating Temperature Range**
- **Available in a Green TSSOP-8 and WSOP-8 Packages**

APPLICATIONS

Video Amplifiers
Video Recorders
Video on Demand (VOD)
Cable and Satellite Set-Top Boxes
Portable and Handheld Products
Communication Devices
SDTVs

PACKAGE/ORDERING INFORMATION

MODEL	PACKAGE DESCRIPTION	SPECIFIED TEMPERATURE RANGE	ORDERING NUMBER	PACKAGE MARKING	PACKING OPTION
SGM9122	TSSOP-8	-40°C to +85°C	SGM9122YTS8/TR	SGM9122YTS8	Tape and Reel, 4000
	WSOP-8	-40°C to +85°C	SGM9122YWS8/TR	SGM9122YWS8	Tape and Reel, 2000

MARKING INFORMATION

NOTE: XXXXX = Date Code and Vendor Code.

XXXXX

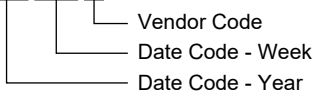

Green (RoHS & HSF): SG Micro Corp defines "Green" to mean Pb-Free (RoHS compatible) and free of halogen substances. If you have additional comments or questions, please contact your SGMICRO representative directly.

- Supply Voltage..... 6V
- Input Voltage.....-0.3V to (V+) + 0.3V
- Power Dissipation, P_D @ T_A = +25°C
- SOIC-8..... 0.8W
- Package Thermal Resistance
- SOIC-8, θ_{JA}.....128°C/W
- Junction Temperature 150°C
- Storage Temperature Range..... -65°C to +150°C
- Lead Temperature (Soldering, 10s) 260°C
- ESD Susceptibility
- HBM..... 4000V
- MM..... 400V

RECOMMENDED OPERATING CONDITIONS

- Operating Voltage Range..... 3.0V to 5.5V
- Operating Temperature Range -40°C to +85°C

OVERSTRESS CAUTION

Stresses beyond those listed in Absolute Maximum Ratings may cause permanent damage to the device. Exposure to absolute maximum rating conditions for extended periods may affect reliability. Functional operation of the device at any conditions beyond those indicated in the Recommended Operating Conditions section is not implied.

ESD SENSITIVITY CAUTION

This integrated circuit can be damaged if ESD protections are not considered carefully. SGMICRO recommends that all integrated circuits be handled with appropriate precautions. Failure to observe proper handling and installation procedures can cause damage. ESD damage can range from subtle performance degradation to complete device failure. Precision integrated circuits may be more susceptible to damage because even small parametric changes could cause the device not to meet the published specifications.

DISCLAIMER

SG Micro Corp reserves the right to make any change in circuit design, or specifications without prior notice.

PIN CONFIGURATION

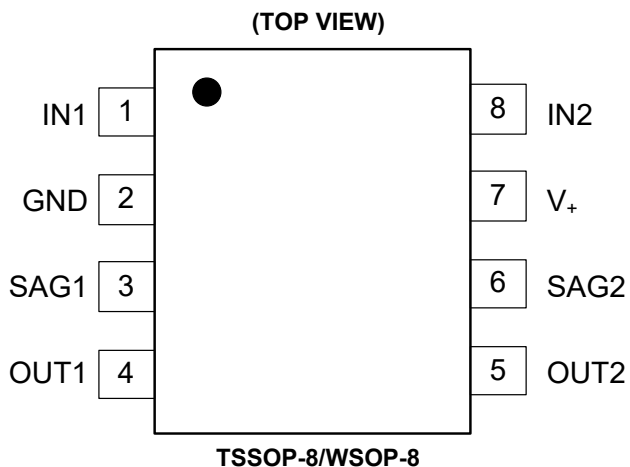

PIN DESCRIPTION

PIN	NAME	FUNCTION
1	IN1	Channel 1 Video Input.
2	GND	Ground.
3	SAG1	Channel 1 SAG Correction Output.
4	OUT1	Channel 1 Output.
5	OUT2	Channel 2 Output.
6	SAG2	Channel 2 SAG Correction Output.
7	V ₊	Power Supply.
8	IN2	Channel 2 Video Input.

ELECTRICAL CHARACTERISTICS

(At $R_L = 150\Omega$ connected to GND, $V_{IN} = 1V_{P-P}$, $T_A = 25^\circ C$ and $C_{IN} = 0.1\mu F$, all outputs AC-coupled with $100\mu F$, unless otherwise noted.)

PARAMETER	CONDITIONS	SGM9122					
		TYP	MIN/MAX OVER TEMPERATURE			UNITS	MIN/ MAX
		+25°C	+25°C	-40°C to +85°C			
Input Characteristics							
Input Voltage Clamp (V_{CLAMP})		170	210	220	mV	MAX	
Clamp Charge Current	$V_{IN} = V_{CLAMP} - 100mV$	-5.6	-7.4	-9.2	mA	MIN	
Output Characteristics							
Output Voltage High Swing	$R_L = 150\Omega$	4.83	4.4	4.3	V	MIN	
Output Voltage Low Swing	$R_L = 150\Omega$	0.26	0.31	0.39	V	MAX	
Power Supply							
Operating Voltage Range			3.0		V	MIN	
			5.5		V	MAX	
Power Supply Rejection Ratio (PSRR)	$V_+ = 3.0V$ to $5.5V$	63	52	46	dB	MIN	
Quiescent Current (I_Q)	$V_{IN} = 500mV$, No load	5.8	7.9	8.9	mA	MAX	
Dynamic Performance							
Voltage Gain (G_V)	$V_{IN} = 1MHz$, $1V_{P-P}$ Sinewave	6.0			dB	TYP	
-0.1dB Bandwidth		8.9			MHz	TYP	
-3dB Bandwidth		15			MHz	TYP	
Gain Offset (G_{CH})	$V_{IN} = 1MHz$, $1V_{P-P}$, $G_{CH} = G_{V1} - G_{V2}$	± 0.1			dB	TYP	
Differential Gain (DG)	NTSC & PAL AC-coupled	0.2			%	TYP	
	NTSC & PAL DC-coupled	0.2			%	TYP	
Differential Phase (DP)	NTSC & PAL AC-coupled	0.4			°	TYP	
	NTSC & PAL DC-coupled	0.6			°	TYP	
Crosstalk	$V_{IN} = 4.43MHz$, $1V_{P-P}$ Sinewave	-60			dB	TYP	
Fall Time	$1V_{STEP}$, 80% to 20%	20			ns	TYP	
Rise Time	$1V_{STEP}$, 80% to 20%	24			ns	TYP	

TYPICAL PERFORMANCE CHARACTERISTICS

At $V_+ = +5.0V$, $T_A = +25^\circ C$, $R_L = 150\Omega$, all outputs AC-coupled with $100\mu F$, unless otherwise noted.

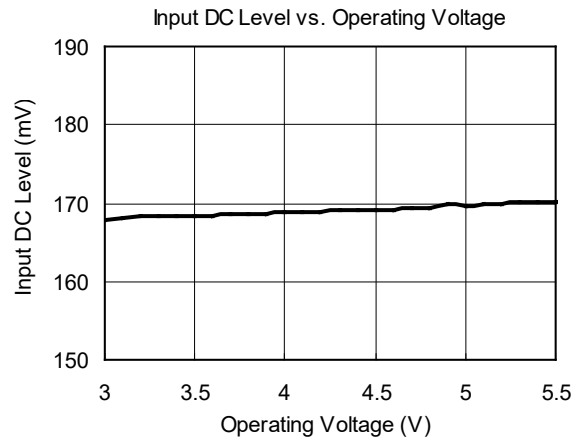
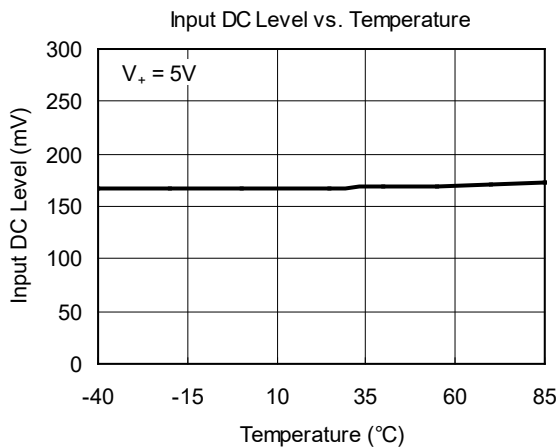
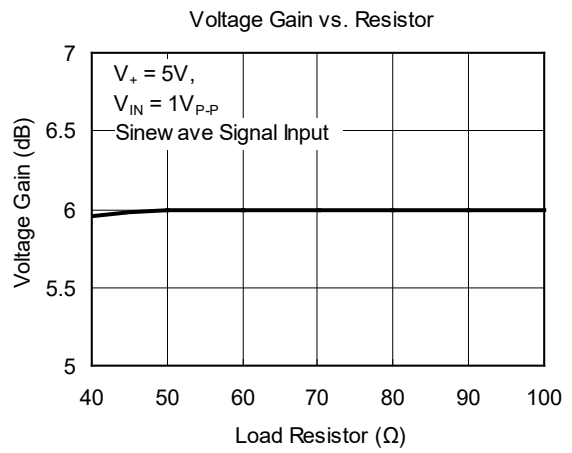
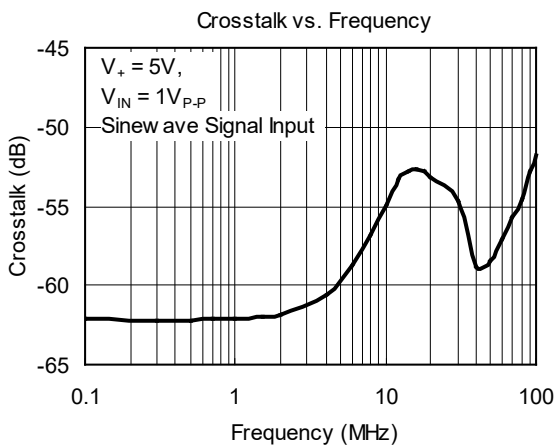
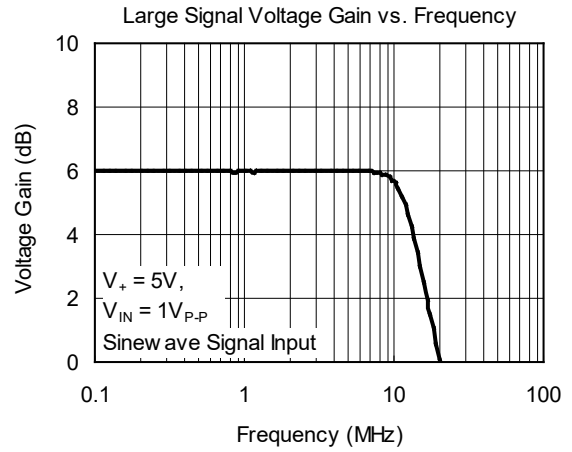
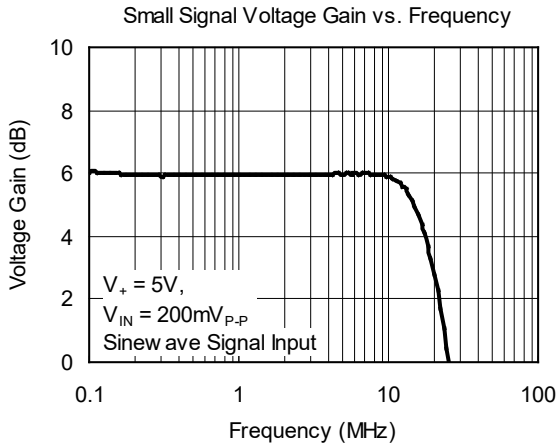

TYPICAL PERFORMANCE CHARACTERISTICS (continued)

At $V_+ = +5.0V$, $T_A = +25^\circ C$, $R_L = 150\Omega$, all outputs AC-coupled with $100\mu F$, unless otherwise noted.

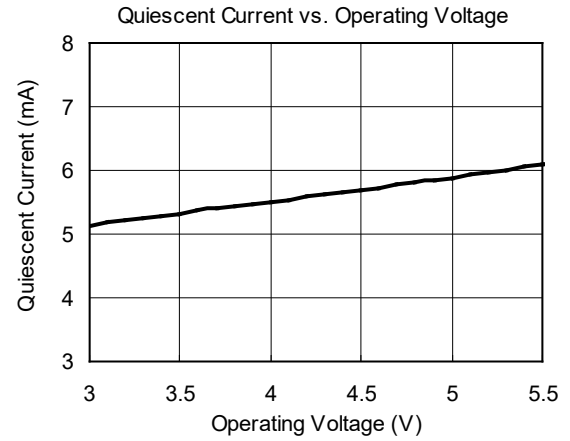
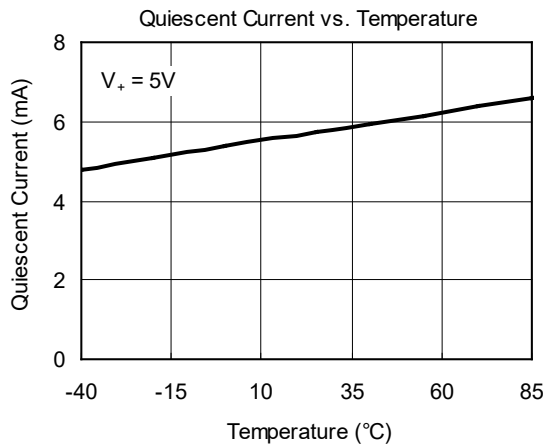
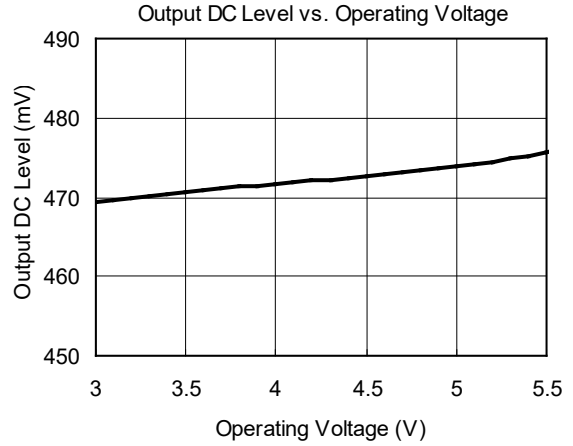
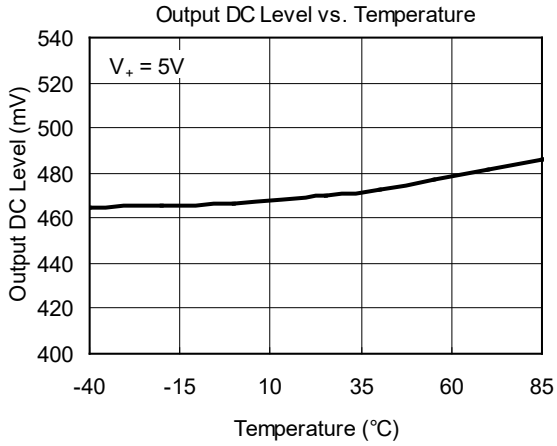

PACKAGE OUTLINE DIMENSIONS

TSSOP-8

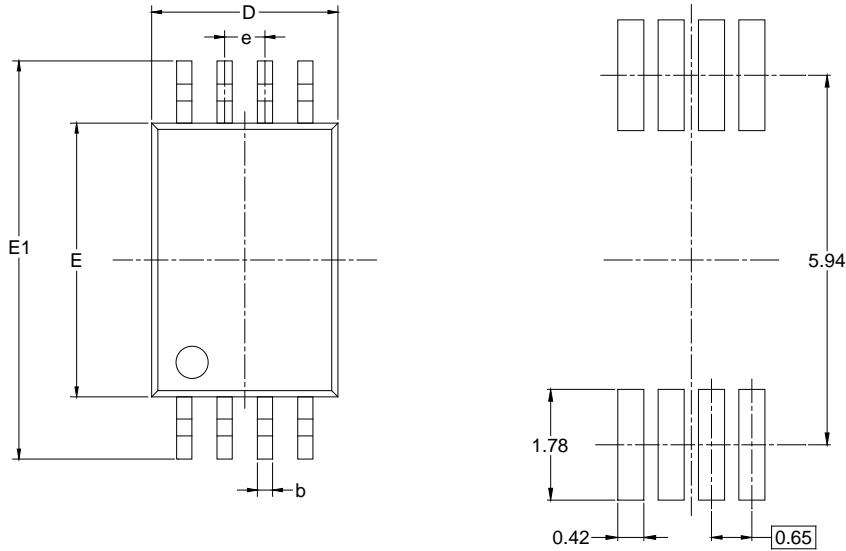

RECOMMENDED LAND PATTERN (Unit: mm)

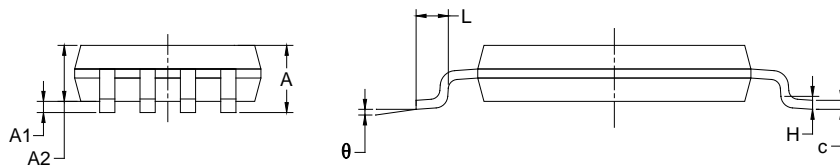

Symbol	Dimensions In Millimeters		Dimensions In Inches	
	MIN	MAX	MIN	MAX
A		1.100		0.043
A1	0.050	0.150	0.002	0.006
A2	0.800	1.000	0.031	0.039
b	0.190	0.300	0.007	0.012
c	0.090	0.200	0.004	0.008
D	2.900	3.100	0.114	0.122
E	4.300	4.500	0.169	0.177
E1	6.250	6.550	0.246	0.258
e	0.650 BSC		0.026 BSC	
L	0.500	0.700	0.02	0.028
H	0.25 TYP		0.01 TYP	
θ	1°	7°	1°	7°

NOTES:

1. Body dimensions do not include mode flash or protrusion.
2. This drawing is subject to change without notice.

PACKAGE OUTLINE DIMENSIONS

WSOP-8

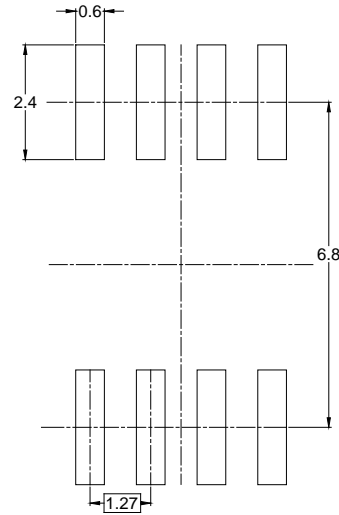
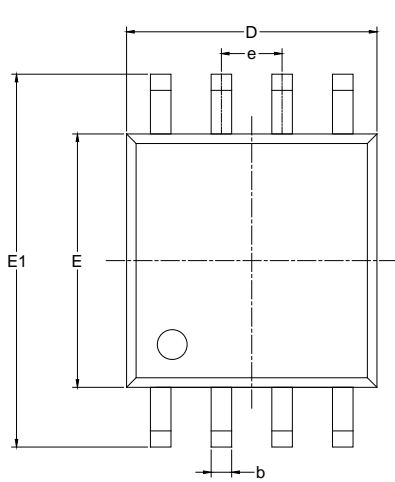

RECOMMENDED LAND PATTERN (Unit: mm)

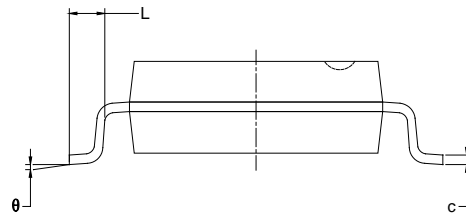
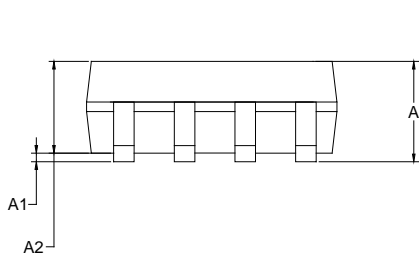

Symbol	Dimensions In Millimeters		
	MIN	TYP	MAX
A	1.70	1.90	2.10
A1	0.05	0.10	0.25
b	0.38	0.43	0.48
c	0.15	0.20	0.25
D	5.14	5.24	5.34
E	5.20	5.30	5.40
E1	7.70	7.80	8.25
e	1.27 TYP		
L	0.55	0.75	0.85
θ	0° ~ 8°		

NOTES:

1. Body dimensions do not include mode flash or protrusion.
2. This drawing is subject to change without notice.

PACKAGE INFORMATION

TAPE AND REEL INFORMATION

REEL DIMENSIONS

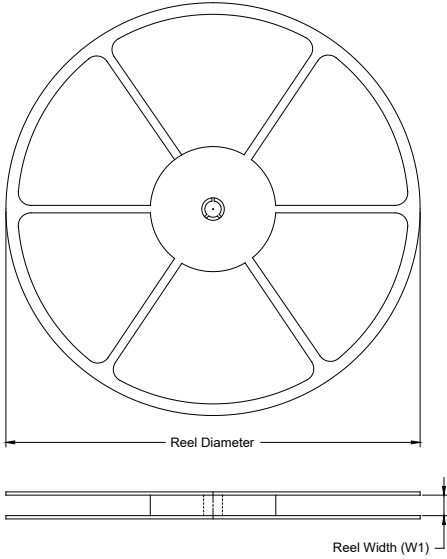

TAPE DIMENSIONS



NOTE: The picture is only for reference. Please make the object as the standard.

KEY PARAMETER LIST OF TAPE AND REEL

Package Type	Reel Diameter	Reel Width W1 (mm)	A0 (mm)	B0 (mm)	K0 (mm)	P0 (mm)	P1 (mm)	P2 (mm)	W (mm)	Pin1 Quadrant
TSSOP-8	13"	12.4	6.76	3.30	1.80	4.0	8.0	2.0	12.0	Q1
WSOP-8	13"	16.4	8.45	5.70	2.35	4.0	12.0	2.0	16.0	Q1

000001

PACKAGE INFORMATION

CARTON BOX DIMENSIONS



NOTE: The picture is only for reference. Please make the object as the standard.

KEY PARAMETER LIST OF CARTON BOX

Reel Type	Length (mm)	Width (mm)	Height (mm)	Pizza/Carton
13"	386	280	370	5

DD0002

单击下面可查看定价，库存，交付和生命周期等信息

[>>SGMICRO\(圣邦微电子\)](#)