

GENERAL DESCRIPTION

The SGM3756 is a high efficiency white LED driver with a 1.2MHz boost converter. With the fixed switching frequency and an internal 40V/1.5A switch FET, the SGM3756 is designed for powering single or parallel LED strings for various size panel backlighting.

The SGM3756 is capable of driving 10 white LEDs in series. The FB feedback voltage is regulated at 200mV typically. The default LED current is programmed by an external R_{SET} resistor. During the operation, the LED current can be controlled by applying a PWM signal to the CTRL pin. The feedback voltage depends on the PWM signal duty cycle. For PWM dimming control, there are no audible noises on the output capacitor.

The SGM3756 integrates LED open protection. It prevents the device from damaging due to the over-voltage during LED open conditions.

The SGM3756 is available in a Green TDFN-2x2-6L package. It operates over an ambient temperature range of -40°C to +85°C.

FEATURES

- Input Voltage Range: 2.7V to 5.5V
- Integrated 40V/1.5A Switch
- Up to 90% Efficiency
- Switching Frequency: 1.2MHz
- Feedback Voltage: 200mV
- PWM Dimming Control
- 38V LED Open Protection for 10 LEDs
- Automatic Soft-Start for Reducing Inrush Current
- 1:250 Stable Luminance Dimming
- Low EMI by Conducting Ringing Cancelling
- Improved PSRR for Waveless Lighting
- Protection Features
 - ♦ Over-Voltage Protection
 - ♦ Under-Voltage Lockout Protection
 - ♦ Thermal Shutdown
- -40°C to +85°C Operating Temperature Range
- Available in a Green TDFN-2x2-6L Package

APPLICATIONS

Smart Phone and Tablet Backlighting
 Handheld Computers, PDAs, GPS Receivers
 Backlight for Media Form Factor Displays

TYPICAL APPLICATION

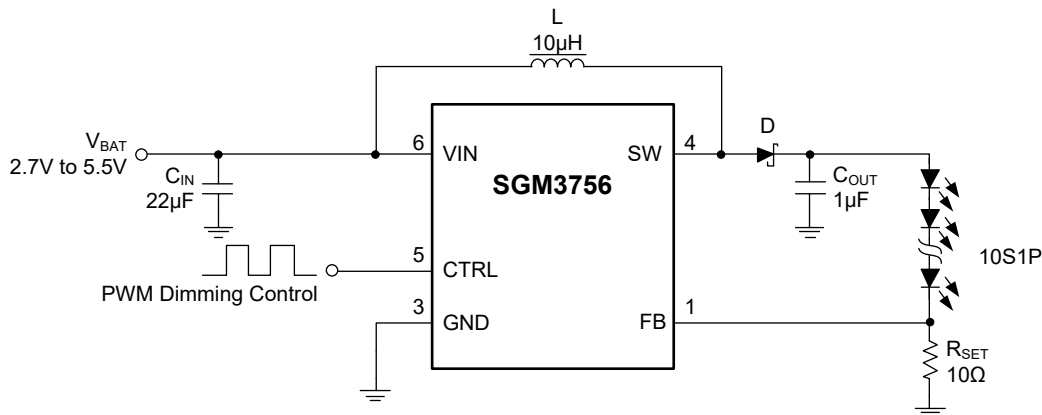

Figure 1. Typical Application

PACKAGE/ORDERING INFORMATION

MODEL	PACKAGE DESCRIPTION	SPECIFIED TEMPERATURE RANGE	ORDERING NUMBER	PACKAGE MARKING	PACKING OPTION
SGM3756	TDFN-2x2-6L	-40°C to +85°C	SGM3756YTDI6G/TR	3756 XXXX	Tape and Reel, 3000

MARKING INFORMATION

NOTE: XXXX = Date Code.

XXXX

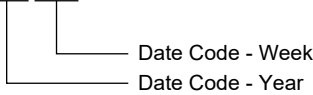

Green (RoHS & HSF): SG Micro Corp defines "Green" to mean Pb-Free (RoHS compatible) and free of halogen substances. If you have additional comments or questions, please contact your SGMICRO representative directly.

ABSOLUTE MAXIMUM RATINGS

- Voltage on VIN, CTRL, FB..... -0.3V to 6V
- Package Thermal Resistance
- TDFN-2x2-6L, θ_{JA} 120°C/W
- Voltage on SW -0.3V to 40V
- Junction Temperature.....+150°C
- Storage Temperature Range-65°C to +150°C
- Lead Temperature (Soldering, 10s).....+260°C
- ESD Susceptibility
- HBM.....2000V
- MM.....200V
- CDM 1000V

RECOMMENDED OPERATING CONDITIONS

- Input Voltage Range2.7V to 5.5V
- Output Voltage Range V_{IN} to 38V
- Inductor..... 4.7 μ H to 10 μ H
- Input Capacitor 1 μ F (MIN)
- Output Capacitor..... 1 μ F to 10 μ F
- Operating Temperature Range-40°C to +85°C

OVERSTRESS CAUTION

Stresses beyond those listed in Absolute Maximum Ratings may cause permanent damage to the device. Exposure to absolute maximum rating conditions for extended periods may affect reliability. Functional operation of the device at any conditions beyond those indicated in the Recommended Operating Conditions section is not implied.

ESD SENSITIVITY CAUTION

This integrated circuit can be damaged if ESD protections are not considered carefully. SGMICRO recommends that all integrated circuits be handled with appropriate precautions. Failure to observe proper handling and installation procedures can cause damage. ESD damage can range from subtle performance degradation to complete device failure. Precision integrated circuits may be more susceptible to damage because even small parametric changes could cause the device not to meet the published specifications.

DISCLAIMER

SG Micro Corp reserves the right to make any change in circuit design, or specifications without prior notice.

PIN CONFIGURATION

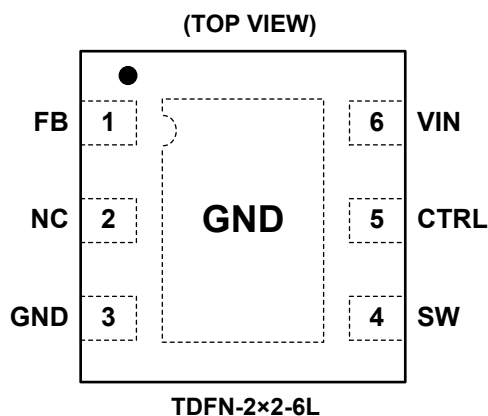

PIN DESCRIPTION

PIN	NAME	I/O	FUNCTION
1	FB	I	Feedback Input for Current. Connect the sense resistor from FB to GND.
2	NC	-	No Connection.
3	GND	O	Ground Pin.
4	SW	I	Drain Connection for Internal N-Channel MOSFET.
5	CTRL	I	PWM Dimming Input.
6	VIN	I	Input Supply Pin.

ELECTRICAL CHARACTERISTICS(V_{IN} = 3.6V, CTRL = V_{IN}, C_{IN} = 22μF, Full = -40°C to +85°C, typical values are at T_A = +25°C, unless otherwise noted.)

PARAMETER	SYMBOL	CONDITIONS	TEMP	MIN	TYP	MAX	UNIT
Power Supply							
Input Voltage Range	V _{IN}		Full	2.7		5.5	V
Under-Voltage Lockout Threshold	UVLO	V _{IN} falling	+25°C		2.2		V
		V _{IN} rising	+25°C		2.3	2.5	
UVLO Hysteresis	V _{HYS}		+25°C		100		mV
Operating Quiescent Current into V _{IN}	I _Q	V _{FB} = 400mV, no switching	+25°C		0.2	0.35	mA
Shutdown Current	I _{SD}	CTRL = GND	+25°C			1	μA
Boost Converter							
Voltage Feedback Regulation Voltage	V _{REF}	PWM duty cycle 100%	+25°C	193.5	200	205.3	mV
		PWM duty cycle 10%	+25°C	18.5	20.3	22.5	mV
		PWM duty cycle 1%	+25°C	1.65	2.5	3.25	mV
		PWM duty cycle 0.2%	+25°C		0.92		mV
FB Pin Bias Current	I _{FB}	V _{FB} = 200mV	Full		0.001	0.3	μA
V _{REF} Filter Time Constant	t _{REF}		+25°C		0.1		ms
N-Channel MOSFET On-Resistance	R _{DS(ON)}		+25°C		0.5	0.8	Ω
Switching Frequency	f _{SW}		Full	0.9	1.2	1.45	MHz
Switching MOSFET Current Limit	I _{LIM}		+25°C	1.15	1.5	1.85	A
Output Voltage Over-Voltage Threshold	V _{OVP_SW}		Full	36	38	39.5	V
Control							
CTRL Logic High Voltage	V _H		Full	1.5			V
CTRL Logic Low Voltage	V _L		Full			0.4	V
CTRL Pin Internal Pull-Down Resistor	R _{PD}		+25°C		600		kΩ
CTRL Logic Low Time to Shutdown	t _{SD}	CTRL high to low	+25°C	2.5			ms
PWM Dimming Frequency Range	DFR		+25°C	10		100	kHz
Minimum PWM On-Time			+25°C	40			ns
Stable Dimming Range	DR		+25°C	0.2		100	%
Thermal Shutdown							
Thermal Shutdown Threshold	T _{SHUTDOWN}				160		°C
Thermal Shutdown Hysteresis	T _{HYS}				20		°C

RECOMMENDED COMPONENTS OF TEST CIRCUITS

COMPONENT		COMPONENT	
INDUCTOR	10 μ H/CD75NP-100KC	CAPACITOR	1 μ F/C2012X7R1H105KT
DIODE	MBR0540		22 μ F/C2012X7R1H226KT

TYPICAL PERFORMANCE CHARACTERISTICS

T_A = +25°C, L = 10 μ H, C_{IN} = 22 μ F, C_{OUT} = 1 μ F, unless otherwise noted.

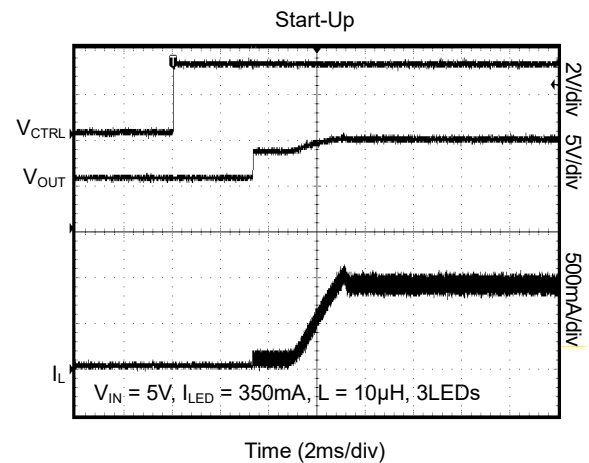
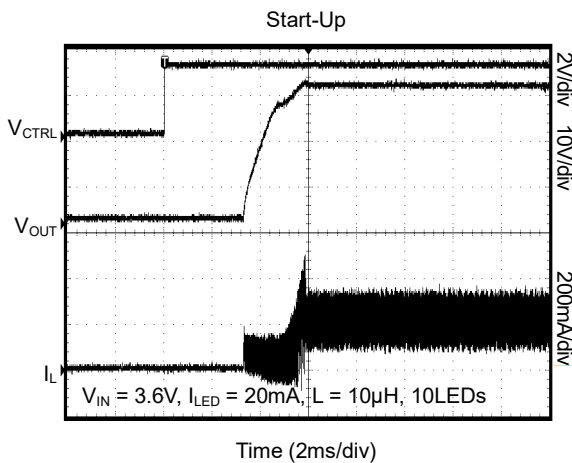
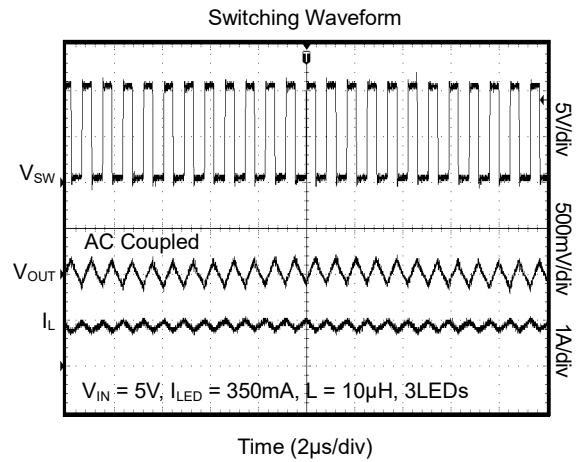
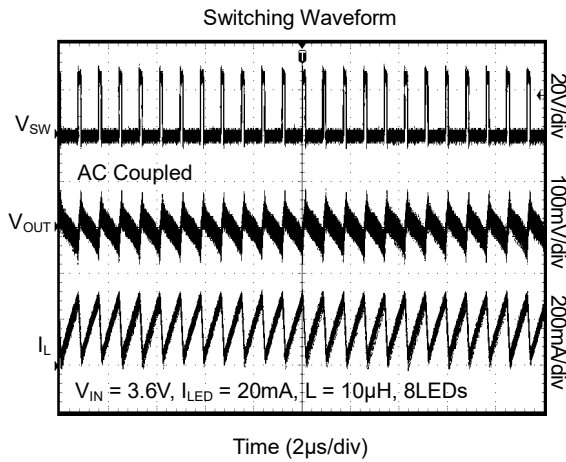
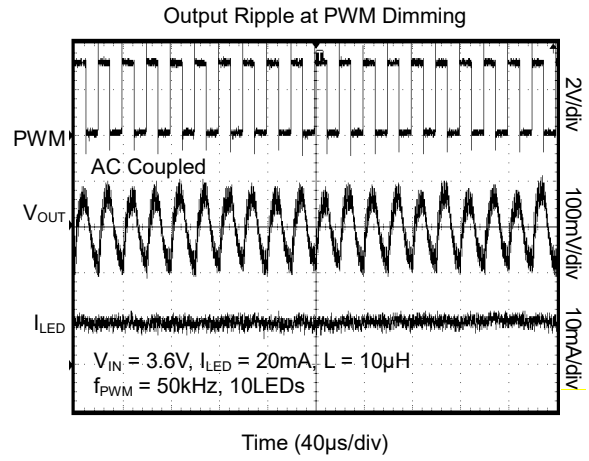
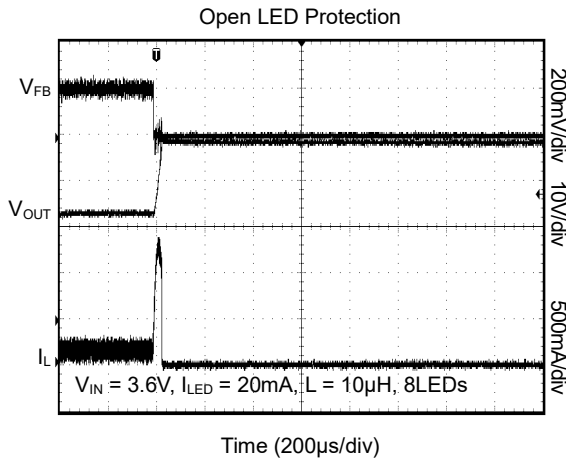

TYPICAL PERFORMANCE CHARACTERISTICS (continued)

T_A = +25°C, L = 10µH, C_{IN} = 22µF, C_{OUT} = 1µF, unless otherwise noted.

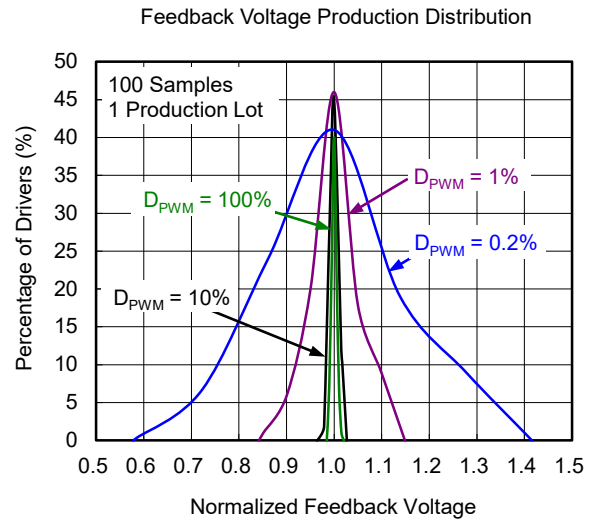
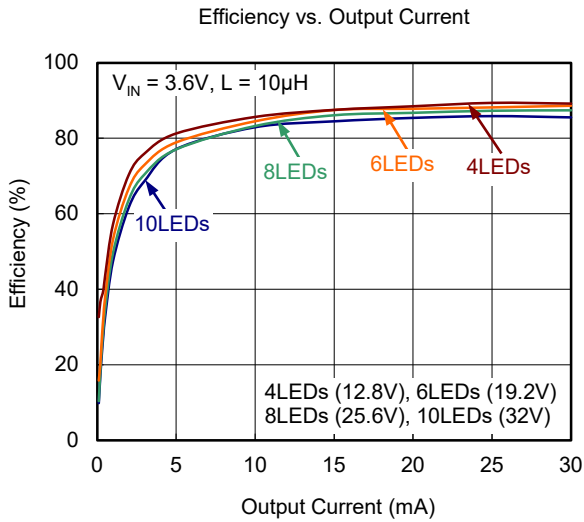
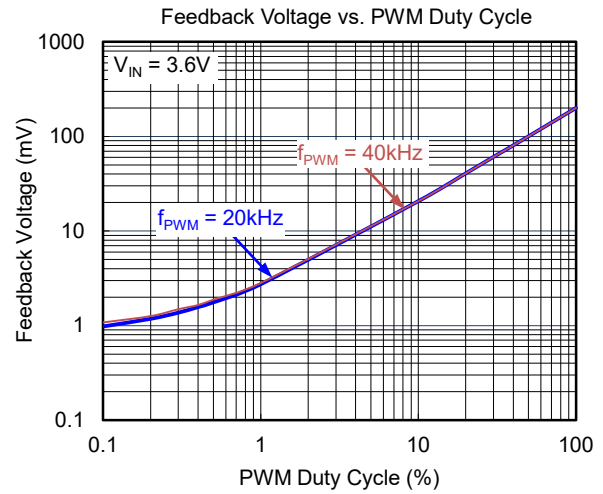
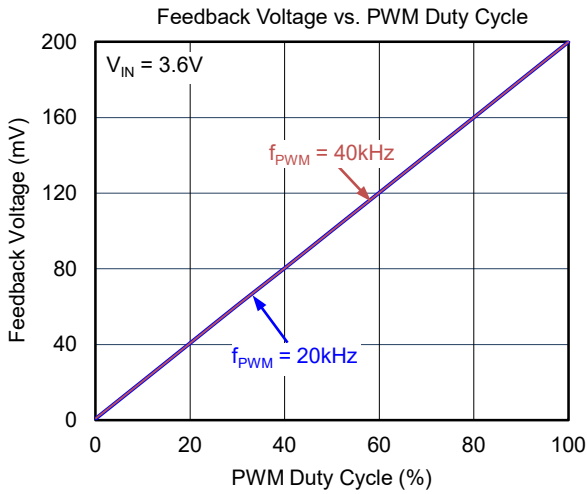

REVISION HISTORY

NOTE: Page numbers for previous revisions may differ from page numbers in the current version.

Changes from Original (JULY 2016) to REV.A

Changed from product preview to production data..... All

PACKAGE OUTLINE DIMENSIONS

TDFN-2x2-6L

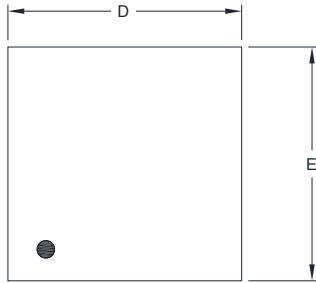

TOP VIEW

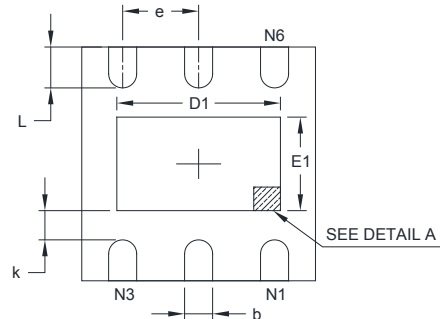

BOTTOM VIEW

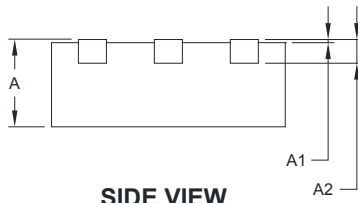

SIDE VIEW

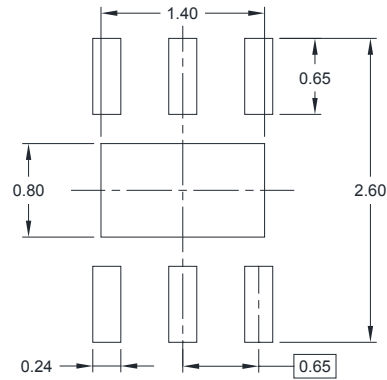

RECOMMENDED LAND PATTERN (Unit: mm)

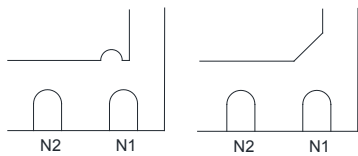

DETAIL A

Pin #1 ID and Tie Bar Mark Options

NOTE: The configuration of the Pin #1 identifier is optional, but must be located within the zone indicated.

Symbol	Dimensions In Millimeters		Dimensions In Inches	
	MIN	MAX	MIN	MAX
A	0.700	0.800	0.028	0.031
A1	0.000	0.050	0.000	0.002
A2	0.203 REF		0.008 REF	
D	1.900	2.100	0.075	0.083
D1	1.100	1.450	0.043	0.057
E	1.900	2.100	0.075	0.083
E1	0.600	0.850	0.024	0.034
k	0.200 MIN		0.008 MIN	
b	0.180	0.300	0.007	0.012
e	0.650 TYP		0.026 TYP	
L	0.250	0.450	0.010	0.018

PACKAGE INFORMATION

TAPE AND REEL INFORMATION

REEL DIMENSIONS



TAPE DIMENSIONS



NOTE: The picture is only for reference. Please make the object as the standard.

KEY PARAMETER LIST OF TAPE AND REEL

Package Type	Reel Diameter	Reel Width W1 (mm)	A0 (mm)	B0 (mm)	K0 (mm)	P0 (mm)	P1 (mm)	P2 (mm)	W (mm)	Pin1 Quadrant
TDFN-2×2-6L	7"	9.5	2.30	2.30	1.10	4.0	4.0	2.0	8.0	Q1

000001

PACKAGE INFORMATION

CARTON BOX DIMENSIONS



NOTE: The picture is only for reference. Please make the object as the standard.

KEY PARAMETER LIST OF CARTON BOX

Reel Type	Length (mm)	Width (mm)	Height (mm)	Pizza/Carton
7" (Option)	368	227	224	8
7"	442	410	224	18

DD0002

单击下面可查看定价，库存，交付和生命周期等信息

[>>SGMICRO\(圣邦微电子\)](#)