

### GENERAL DESCRIPTION

The SGM6623 is a general-purpose miniature boost DC/DC switching regulator with high-efficiency for battery-backup and standby power systems. The acceptable input voltage range of 0.8V to 12V can be converted to a regulated 3.3V to 13V output voltage with efficiency as high as 90%. SGM6623 can be used as backup charger for systems with 1- to 4-cell batteries. It operates at a 600kHz nominal switching frequency, allowing the use of small and low-profile inductor for compact design. It also has several built-in protection features, such as cycle-by-cycle over-current limit, soft-start, thermal shutdown and open loop over-voltage protection.

The SGM6623 is available in a Green SOT-23-6 package.

### FEATURES

- 0.8V to 12V Input Voltage Range
- 3.3V to 13V Wide Output Voltage Range
- 4.4A Current Limited Integrated Switch
- Up to 90% Efficiency
- 600kHz Nominal Fixed Switching Frequency with Pulse Skipping at Light Loads
- Built-In Soft-Start Function
- Open Loop Over-Voltage Protection
- Enable Input Pin
- 47µA Typical Quiescent Current (to VS Pin)
- 0.4µA Typical Supply Current in Shutdown
- Available in a Green SOT-23-6 Package

### APPLICATIONS

- Mobile Phones
- Portable Equipment
- Hand-Held Instruments
- 1-, 2-, 3- or 4-Cell Battery Systems

### TYPICAL APPLICATION

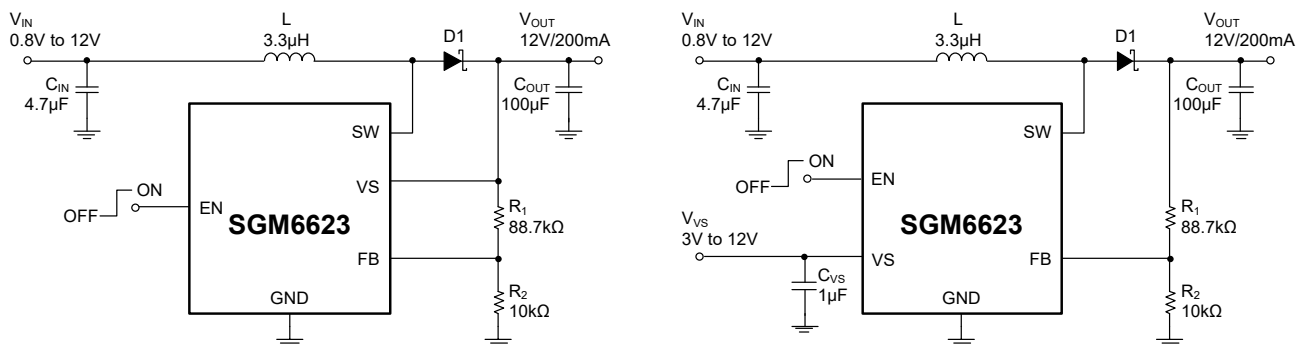

Figure 1. Typical Application Circuits

**PACKAGE/ORDERING INFORMATION**

MODEL	PACKAGE DESCRIPTION	SPECIFIED TEMPERATURE RANGE	ORDERING NUMBER	PACKAGE MARKING	PACKING OPTION
SGM6623	SOT-23-6	-40°C to +85°C	SGM6623YN6G/TR	CB4XX	Tape and Reel, 3000

**MARKING INFORMATION**

NOTE: XX = Date Code.

**YYY X X**

Date Code - Week  
Date Code - Year  
Serial Number

Green (RoHS & HSF): SG Micro Corp defines "Green" to mean Pb-Free (RoHS compatible) and free of halogen substances. If you have additional comments or questions, please contact your SGMICRO representative directly.

**ABSOLUTE MAXIMUM RATINGS**

Voltages on EN and FB ..... -0.3V to 6V  
 Voltages on SW and VS ..... -0.3V to 14.5V  
 Package Thermal Resistance  
 SOT-23-6,  $\theta_{JA}$  ..... 190°C/W  
 Junction Temperature ..... +150°C  
 Storage Temperature Range..... -65°C to +150°C  
 Lead Temperature (Soldering, 10s) ..... +260°C  
 ESD Susceptibility  
 HBM..... 3000V  
 CDM ..... 1000V

**RECOMMENDED OPERATING CONDITIONS**

Operating Ambient Temperature Range..... -40°C to +85°C  
 Operating Junction Temperature Range..... -40°C to +125°C

**OVERSTRESS CAUTION**

Stresses beyond those listed in Absolute Maximum Ratings may cause permanent damage to the device. Exposure to absolute maximum rating conditions for extended periods may affect reliability. Functional operation of the device at any conditions beyond those indicated in the Recommended Operating Conditions section is not implied.

**ESD SENSITIVITY CAUTION**

This integrated circuit can be damaged by ESD if you don't pay attention to ESD protection. SGMICRO recommends that all integrated circuits be handled with appropriate precautions. Failure to observe proper handling and installation procedures can cause damage. ESD damage can range from subtle performance degradation to complete device failure. Precision integrated circuits may be more susceptible to damage because very small parametric changes could cause the device not to meet its published specifications.

**DISCLAIMER**

SG Micro Corp reserves the right to make any change in circuit design, or specifications without prior notice.

## PIN CONFIGURATION

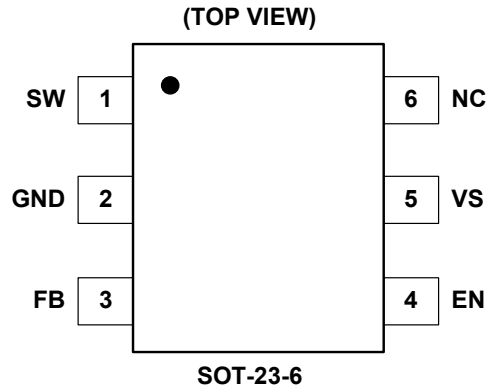

## PIN DESCRIPTION

PIN	NAME	I/O	FUNCTION
1	SW	I	Switching Node of the Device. Connect to the input source through the boost inductor.
2	GND	G	Ground.
3	FB	I	Feedback input to the error amplifier for regulated output.
4	EN	I	Enable Pin of the Boost Regulator. Logic low disables the chip and logic high enables it. It needs to be pulled up to enable the device, otherwise the weak internal pull-down will disable it. Two levels logic or analog bias with edge slope rate > 10V/ms is desired for stable on/off transition.
5	VS	I	Supply Power Input for Internal Circuit. Connect to the output of converter.
6	NC	—	Not connected. Recommend to solder it onto ground plane for better thermal dissipation.

NOTE: I = Input, O = Output, G = Ground.

**ELECTRICAL CHARACTERISTICS**(V<sub>VS</sub> = 3.6V, V<sub>EN</sub> = 3.6V, Full = -40°C to +85°C, typical values are at T<sub>J</sub> = +25°C, unless otherwise noted.)

PARAMETER	SYMBOL	CONDITIONS	TEMP	MIN	TYP	MAX	UNITS
<b>Supply Current</b>							
Sustainable Input Voltage Range	V <sub>IN</sub>	The VS pin connects to output	+25°C	0.8		12	V
Minimum VS Voltage for Start-Up	V <sub>VS_START_MIN</sub>	The VS pin connects to output	+25°C		1.5		V
VS Input Voltage Range	V <sub>VS</sub>	V <sub>IN</sub> is in 0.8V to 12.5V range	+25°C	3		13	V
Operating Quiescent Current into VS	I <sub>Q</sub>	No switching, no load	Full		47	65	μA
Shutdown Current	I <sub>SHDN</sub>	V <sub>EN</sub> = GND	+25°C			1	μA
			Full			1.5	
<b>Enable and Reference Control</b>							
EN Logic High Voltage	V <sub>IH</sub>		Full	1.1			V
EN Logic Low Voltage	V <sub>IL</sub>		Full			0.3	V
EN Internal Pull-Down Resistor	R <sub>EN</sub>		Full	400	570	740	kΩ
<b>Voltage and Current Control</b>							
Voltage Feedback Regulation Voltage	V <sub>REF</sub>		Full	1.177	1.205	1.231	V
Voltage Feedback Input Bias Current	I <sub>FB</sub>	V <sub>FB</sub> = 1.3V	Full			170	nA
Switching Frequency	f <sub>SW</sub>		Full	480	600	720	kHz
Maximum Duty Cycle	D <sub>MAX</sub>		+25°C		96		%
Over-Voltage Protection Threshold	V <sub>OVP</sub>		+25°C	13.3	13.8	14.3	V
Over-Voltage Protection Threshold Hysteresis	V <sub>OVP_HYS</sub>		+25°C		0.43		V
<b>Power Switch</b>							
N-Channel MOSFET On-Resistance	R <sub>DSON</sub>	V <sub>VS</sub> = 3.6V	+25°C		70	90	mΩ
			Full			110	
N-Channel Leakage Current	I <sub>LN_NFET</sub>	V <sub>SW</sub> = 13.2V, V <sub>EN</sub> = 0V	+25°C			1	μA
			Full			1.5	
N-Channel MOSFET Current Limit	I <sub>LIM</sub>		+25°C	3.65	4.4	5.25	A
<b>Thermal Shutdown</b>							
Thermal Shutdown Threshold	T <sub>SHDN</sub>				165		°C
Thermal Shutdown Threshold Hysteresis	T <sub>HYS</sub>				15		°C

TYPICAL PERFORMANCE CHARACTERISTICS

$T_J = +25^\circ\text{C}$ ,  $C_{IN} = 4.7\mu\text{F}$ ,  $C_{OUT} = 100\mu\text{F}$ ,  $L = 3.3\mu\text{H}$  and  $V_{VS} = V_{OUT}$ , unless otherwise noted.

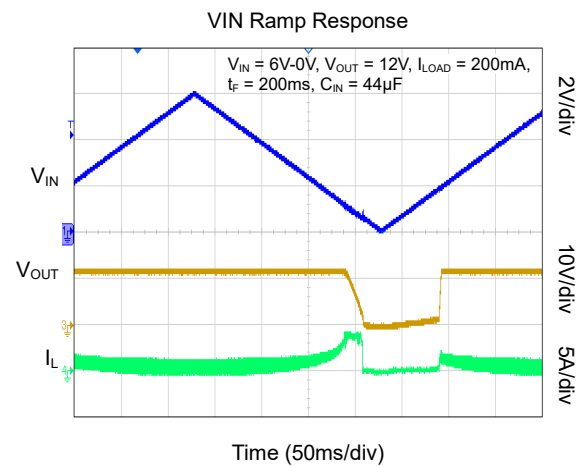
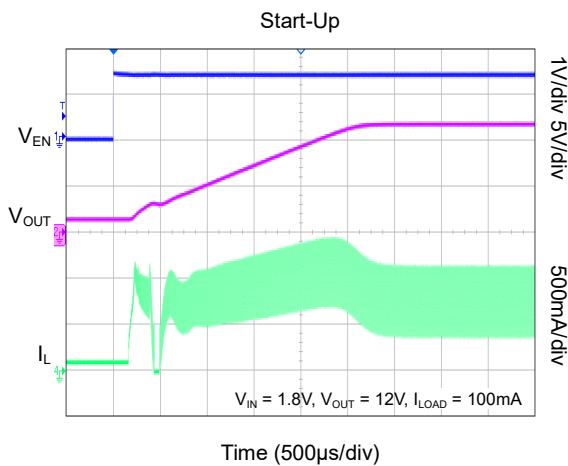
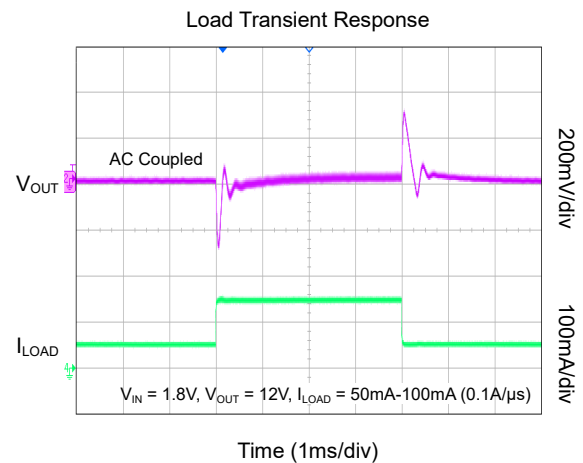
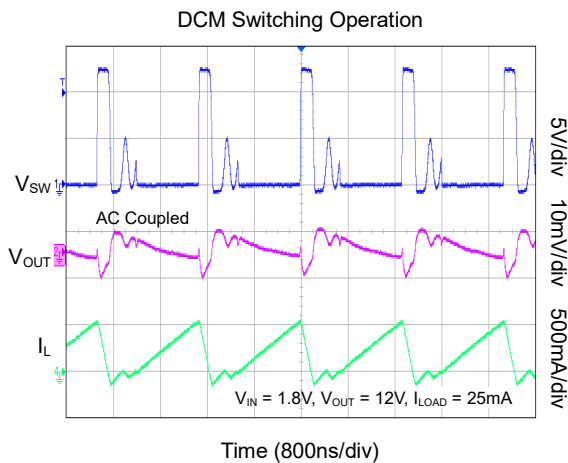
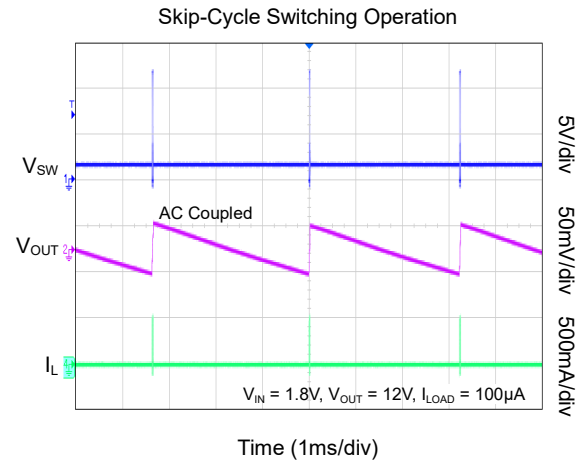
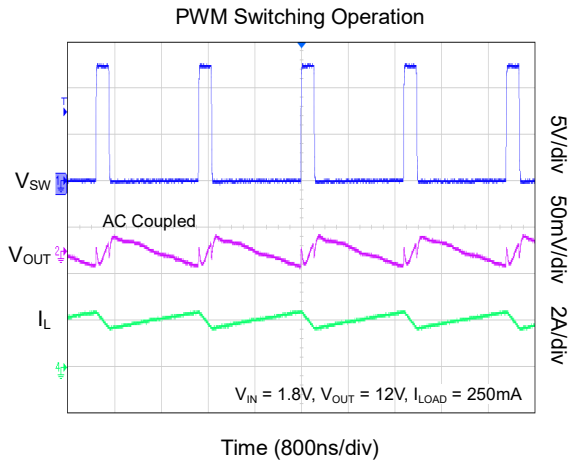

TYPICAL PERFORMANCE CHARACTERISTICS (continued)

$T_J = +25^\circ\text{C}$ ,  $C_{IN} = 4.7\mu\text{F}$ ,  $C_{OUT} = 100\mu\text{F}$ ,  $L = 3.3\mu\text{H}$  and  $V_{VS} = V_{OUT}$ , unless otherwise noted.

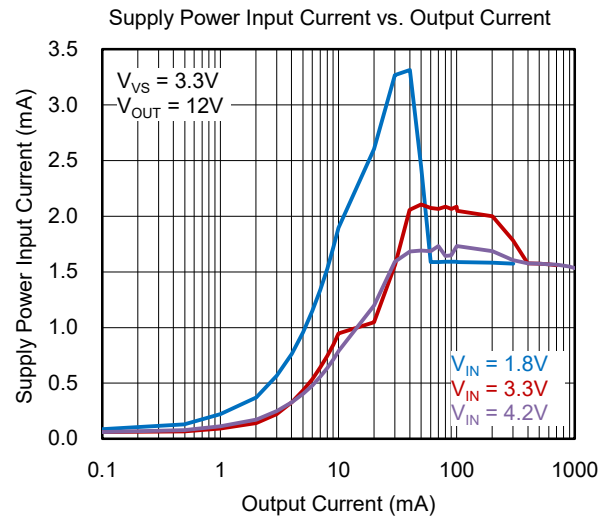
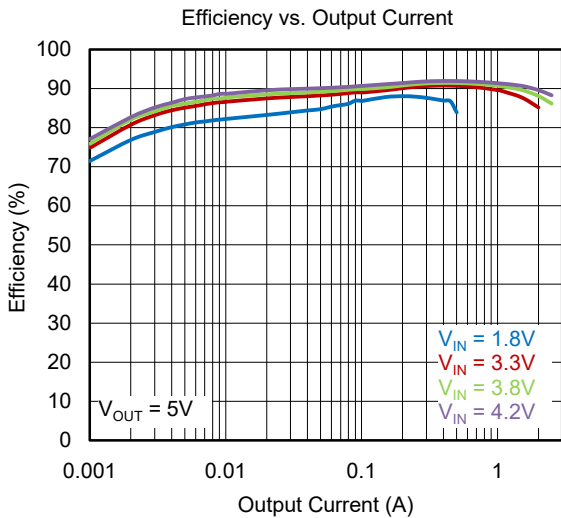
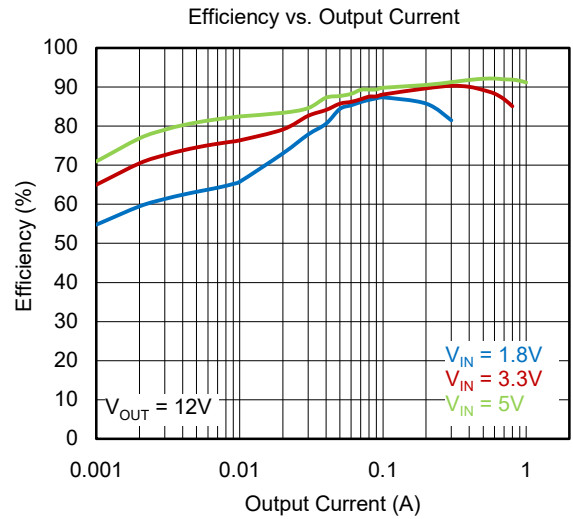
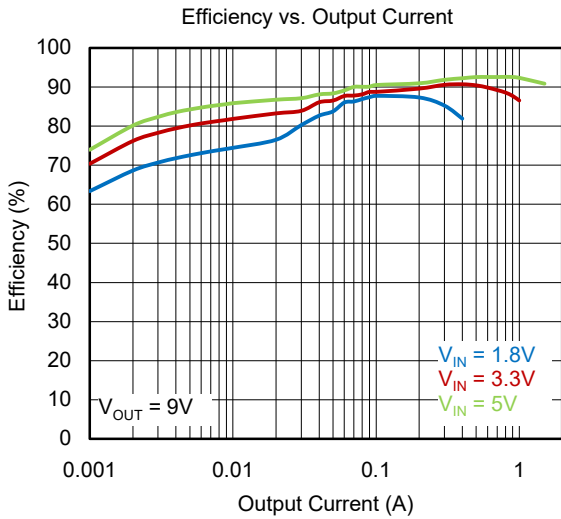
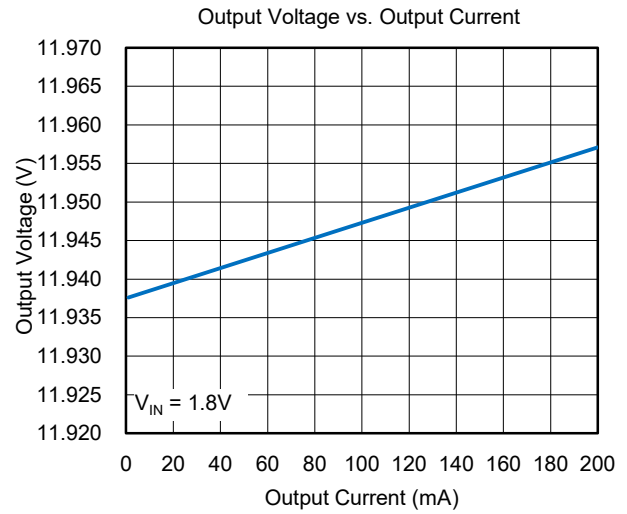
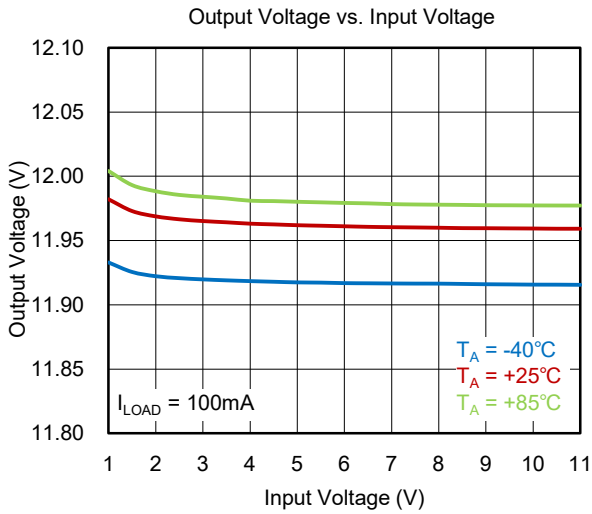

FUNCTIONAL BLOCK DIAGRAM

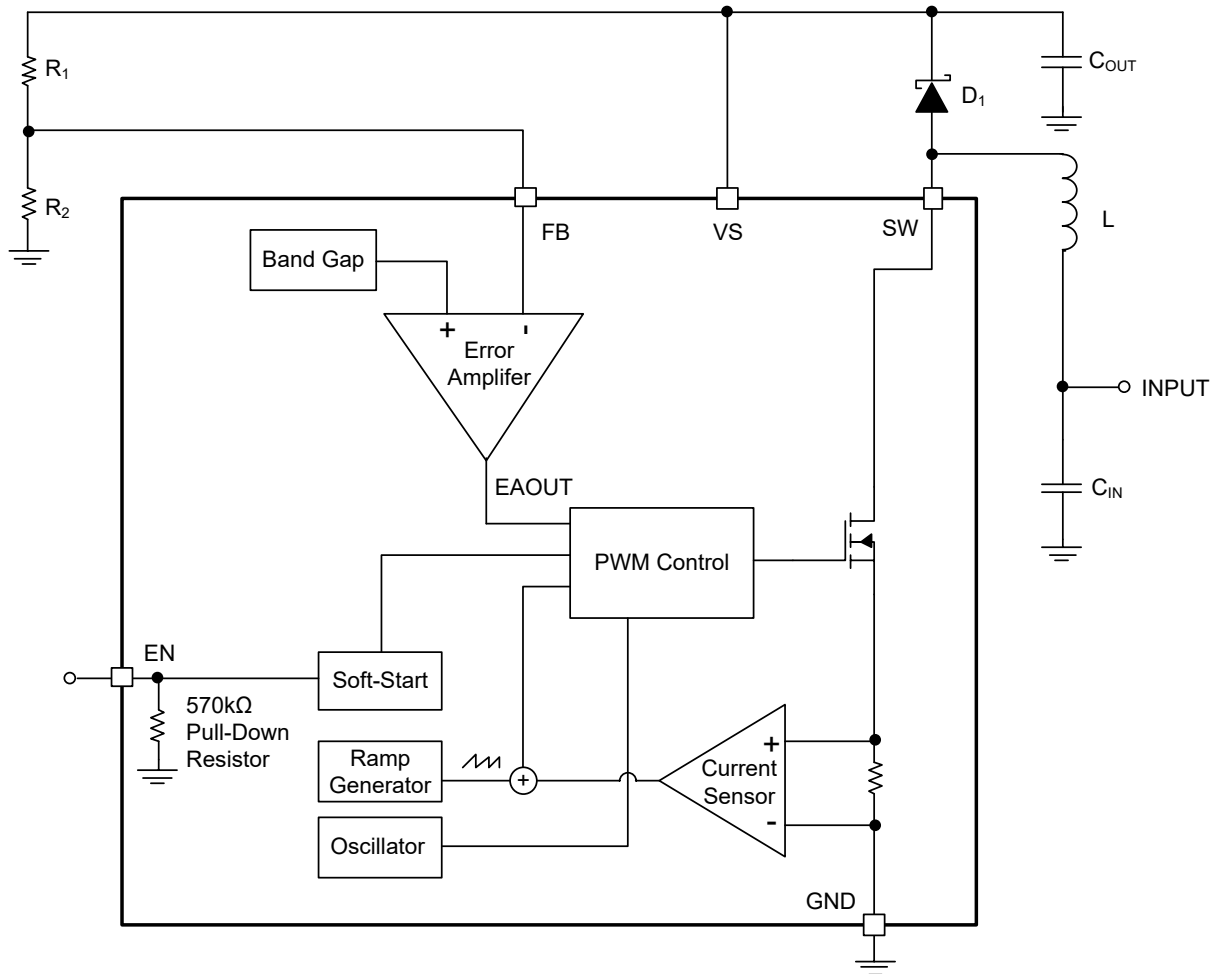

Figure 2. Block Diagram

REVISION HISTORY

NOTE: Page numbers for previous revisions may differ from page numbers in the current version.

SEPTEMBER 2021 – REV.A.2 to REV.A.3	Page
Updated Pin Description section .....	3
JULY 2020 – REV.A.1 to REV.A.2	Page
Updated switching frequency .....	1, 4, 7
FEBRUARY 2020 – REV.A to REV.A.1	Page
Updated Pin Description section .....	3
Updated Detailed Description section .....	8
Changes from Original (SEPTEMBER 2019) to REV.A	Page
Changed from product preview to production data .....	All

PACKAGE OUTLINE DIMENSIONS

SOT-23-6

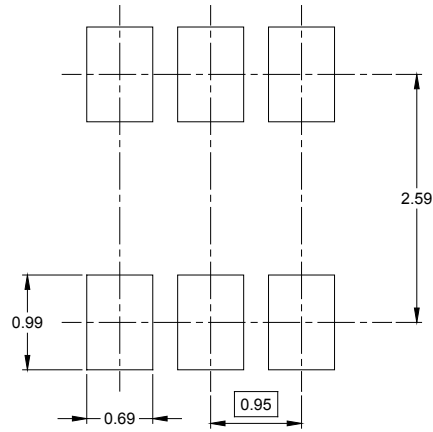
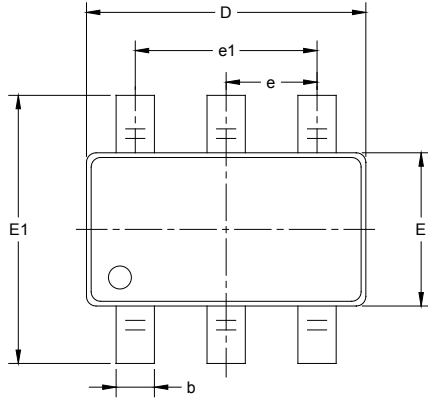

RECOMMENDED LAND PATTERN (Unit: mm)

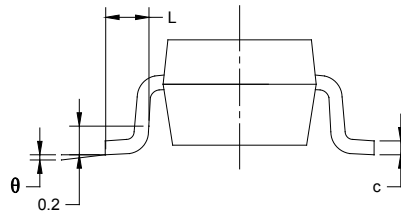
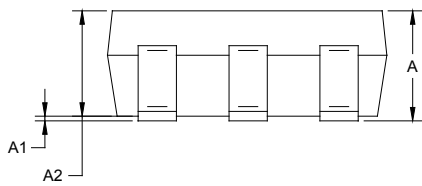

Symbol	Dimensions In Millimeters		Dimensions In Inches	
	MIN	MAX	MIN	MAX
A	1.050	1.250	0.041	0.049
A1	0.000	0.100	0.000	0.004
A2	1.050	1.150	0.041	0.045
b	0.300	0.500	0.012	0.020
c	0.100	0.200	0.004	0.008
D	2.820	3.020	0.111	0.119
E	1.500	1.700	0.059	0.067
E1	2.650	2.950	0.104	0.116
e	0.950 BSC		0.037 BSC	
e1	1.900 BSC		0.075 BSC	
L	0.300	0.600	0.012	0.024
$\theta$	0°	8°	0°	8°



# PACKAGE INFORMATION

## TAPE AND REEL INFORMATION

### REEL DIMENSIONS



### TAPE DIMENSIONS



NOTE: The picture is only for reference. Please make the object as the standard.

### KEY PARAMETER LIST OF TAPE AND REEL

Package Type	Reel Diameter	Reel Width W1 (mm)	A0 (mm)	B0 (mm)	K0 (mm)	P0 (mm)	P1 (mm)	P2 (mm)	W (mm)	Pin1 Quadrant
SOT-23-6	7"	9.5	3.17	3.23	1.37	4.0	4.0	2.0	8.0	Q3

000001

# PACKAGE INFORMATION

## CARTON BOX DIMENSIONS



NOTE: The picture is only for reference. Please make the object as the standard.

## KEY PARAMETER LIST OF CARTON BOX

Reel Type	Length (mm)	Width (mm)	Height (mm)	Pizza/Carton
7" (Option)	368	227	224	8
7"	442	410	224	18

DD0002

单击下面可查看定价，库存，交付和生命周期等信息

[>>SGMICRO\(圣邦微电子\)](#)