



SGM41285

70V, 300mW Boost Converter and Current Monitor for APD Bias Applications

GENERAL DESCRIPTION

SGM41285 is a boost DC-DC converter with a wide input voltage range of 2.8V to 5.5V. This device can deliver a maximum of 70V output voltage and 4mA monitoring current limit. The 850kHz fixed switching frequency and PWM mode allow this device to minimize noise of output voltage. The constant PWM frequency provides easy filtering of output voltage in low noise applications.

This device integrates the fast biased avalanche photodiode (APD) current monitor limit with 1 μ s response time. The current limiting function with adjustable resistors protects the APD from the effects of optical power transients. The SGM41283 integrates various protection features such as soft-start, cycle-by-cycle current limit, under-voltage lockout (UVLO) and thermal shutdown.

The SGM41285 is available in a Green TQFN-3 \times 3-16L package. It operates over an ambient temperature range of -40 $^{\circ}$ C to +125 $^{\circ}$ C.

FEATURES

- 2.8V to 5.5V Input Voltage Range
- ($V_{IN} + 5V$) to 70V Wide Output Voltage Range
- 850kHz Fixed Switching Frequency
- Internal 0.6 Ω (TYP) 72V MOSFET
- Less than 1 μ A Shutdown Current
- Boost Converter Output Power:
SGM41285A: 300mW
SGM41285B: 200mW
- High-side Current Monitor Ratios:
SGM41285A: 1:1
SGM41285B: 5:1
- Accurate High-side APD Current Monitor with 1:1 and 5:1 Ratios
- Resistor-Adjustable Ultra-Fast APD Current Limit (1 μ s Response Time)
- Open-Drain Current-Limit Indicator Flag
- Constant PWM Frequency Provides Easy Filtering in Low Noise Applications
- Internal Soft-Start Function
- -40 $^{\circ}$ C to +125 $^{\circ}$ C Operating Temperature Range
- Available in a Green TQFN-3 \times 3-16L Package

APPLICATIONS

Avalanche Photodiode Bias and Monitor
Supply for PIN Diode Bias
Supply for Low-Noise Varactor Diode Bias
FBON and GPON Modules

70V, 300mW Boost Converter and Current Monitor for APD Bias Applications

SGM41285

PACKAGE/ORDERING INFORMATION

MODEL	PACKAGE DESCRIPTION	SPECIFIED TEMPERATURE RANGE	ORDERING NUMBER	PACKAGE MARKING	PACKING OPTION
SGM41285A	TQFN-3×3-16L	-40°C to +125°C	SGM41285AXTQ16G/TR	GMDTQ XXXXX	Tape and Reel, 4000
SGM41285B	TQFN-3×3-16L	-40°C to +125°C	SGM41285BXTQ16G/TR	GMETQ XXXXX	Tape and Reel, 4000

MARKING INFORMATION

SGM41285A

(1) XXXXX = Date Code, Trace Code and Vendor Code.

XXXXX

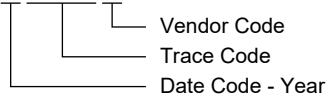

SGM41285B

(2) XXXXX = Date Code and Vendor Code.

XXXXX

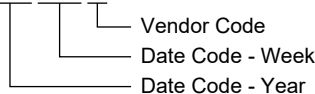

Green (RoHS & HSF): SG Micro Corp defines "Green" to mean Pb-Free (RoHS compatible) and free of halogen substances. If you have additional comments or questions, please contact your SGMICRO representative directly.

ABSOLUTE MAXIMUM RATINGS

IN, nSHDN, FB, nILIM, RLIM, CNTRL, CLAMP to SGND

.....	-0.3V to 6V
SW to PGND.....	-0.3V to 76V
BIAS to SGND	-0.3V to 76V
APD, to SGND	-0.3V to (V _{BIAS} + 0.3V)
PGND to SGND	-0.3V to 0.3V
MOUT to SGND.....	-0.3V to (V _{CLAMP} + 0.3V)
Package Thermal Resistance	
TQFN-3×3-16L, θ _{JA}	45°C/W
Junction Temperature.....	+150°C
Storage Temperature Range	-65°C to +150°C
Lead Temperature (Soldering, 10s).....	+260°C
ESD Susceptibility	
HBM.....	4000V
MM.....	200V
CDM	1000V

RECOMMENDED OPERATING CONDITIONS

Input Voltage Range	2.8V to 5.5V
Operating Ambient Temperature Range	-40°C to +125°C
Operating Junction Temperature Range.....	-40°C to +125°C

OVERSTRESS CAUTION

Stresses beyond those listed in Absolute Maximum Ratings may cause permanent damage to the device. Exposure to absolute maximum rating conditions for extended periods may affect reliability. Functional operation of the device at any conditions beyond those indicated in the Recommended Operating Conditions section is not implied.

ESD SENSITIVITY CAUTION

This integrated circuit can be damaged by ESD if you don't pay attention to ESD protection. SGMICRO recommends that all integrated circuits be handled with appropriate precautions. Failure to observe proper handling and installation procedures can cause damage. ESD damage can range from subtle performance degradation to complete device failure. Precision integrated circuits may be more susceptible to damage because very small parametric changes could cause the device not to meet its published specifications.

DISCLAIMER

SG Micro Corp reserves the right to make any change in circuit design, or specifications without prior notice.

PIN CONFIGURATION

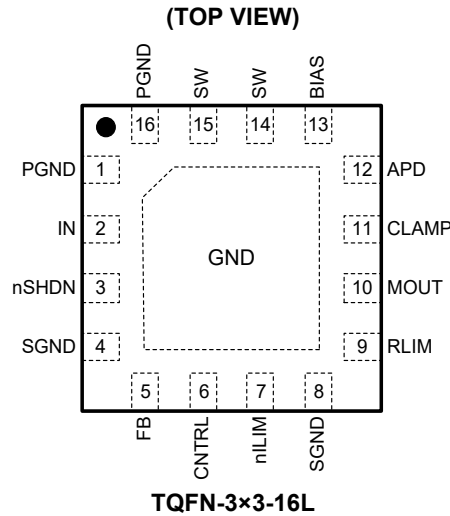

PIN DESCRIPTION

PIN	NAME	FUNCTION
1, 16	PGND	Power Ground. This pin connects to the negative terminals of the input and output capacitors. It connects to SGND at an external single point, usually at the return terminal of the output capacitor.
2	IN	Input Supply Voltage. Use a ceramic capacitor with a minimum value of 1µF to bypass IN to PGND.
3	nSHDN	Active Low Shutdown Control Input. Logic low to nSHDN shuts down the device. Connect it to IN for normal operation.
4, 8	SGND	Signal Ground. Connect to the ground directly. Connect SGND to PGND at a single point, usually close to the return terminal of the output capacitor.
5	FB	Feedback Regulation Input. Connect to the resistive voltage divider's center tap.
6	CNTRL	Control Input for Boost Converter. When $V_{CNTRL} < 1.2V$, this pin could set the feedback set-point voltage externally. When $V_{CNTRL} > 1.3V$, the internal 1.20V (TYP) feedback set-point voltage can be used.
7	nILIM	Open-Drain Current-Limit Indicator. This pin is set low when exceeding APD current limit.
9	RLIM	Current-Limit Resistor Connection. A resistor between RLIM and SGND programs the APD current-limit threshold. When RLIM connects to SGND, the current limit is set to 4.5mA.
10	MOUT	Current Monitor Output. For the SGM41285A, it provides 100% APD current. For the SGM41285B, it provides 20% APD current.
11	CLAMP	Clamp Voltage Input. This pin is an external potential used for MOUT voltage clamp.
12	APD	Reference Current Output. APD provides the source current to the cathode of the photodiode.
13	BIAS	Bias Voltage Input. A current source for APD. Connect this pin directly or through a low-pass filter to the output for ripple attenuation. It provides voltage bias for the current monitor.
14, 15	SW	Drain of Internal 72V N-Channel DMOS. Connect inductor to SW. Connect to SW with the shortest path to reduce switching noise emission.
-	Exposed Pad	Exposed Pad. The thermal dissipation is improved by connecting to a large copper plane at the SGND and PGND potential. It is not the only ground connection.

70V, 300mW Boost Converter and Current Monitor for APD Bias Applications

SGM41285

ELECTRICAL CHARACTERISTICS

($V_{IN} = V_{nSHDN} = V_{CNTRL} = 3.3V$, $V_{BIAS} = 40V$, $V_{MOUT} = 0V$, $V_{PGND} = V_{SGND} = 0V$, $C_{IN} = 1\mu F$, $SW = APD = CLAMP = nLIM =$ unconnected, Full = $-40^{\circ}C$ to $+125^{\circ}C$, typical values are at $T_A = +25^{\circ}C$, unless otherwise noted.)

PARAMETER	SYMBOL	CONDITIONS	TEMP	MIN	TYP	MAX	UNITS	
Input Supply								
Supply Voltage Range	V_{IN}		Full	2.8		5.5	V	
Supply Current	I_{SUPPLY}	$V_{FB} = 1.4V$, no switching	Full		190	280	μA	
Under-Voltage Lockout Threshold	V_{UVLO}	V_{IN} rising	Full	2.4	2.5	2.6	V	
Under-Voltage Lockout Hysteresis	V_{UVLO_HYS}		$+25^{\circ}C$		200		mV	
Shutdown Current	I_{SHDN}	$V_{nSHDN} = 0V$	Full		0.01	1	μA	
Shutdown Bias Current	I_{BIAS_SHDN}	$V_{BIAS} = 3.3V$, $V_{nSHDN} = 0V$	Full		0.01	0.6	μA	
Boost Converter								
Output-Voltage Adjustment Range			Full	$V_{IN} + 5$		70	V	
Switching Frequency	f_{SW}		Full	750	850	950	kHz	
Maximum Duty Cycle	D_{MAX}		$+25^{\circ}C$	87.5	90	92.5	%	
FB Set-Point Voltage	V_{FB_SET}		Full	1.175	1.20	1.225	V	
FB Input-Bias Current	I_{FB}	$V_{FB} = V_{FB_SET}$	$+25^{\circ}C$			400	nA	
Internal Switch On-Resistance	R_{ON}	$I_{SW} = 100mA$	Full		0.6	1.2	Ω	
Peak Switch Current Limit	I_{LIM_SW}		$+25^{\circ}C$	0.9	1.1	1.35	A	
Peak Current-Limit Response			$+25^{\circ}C$		100		ns	
Switch Leakage Current		$V_{SW} = 72V$	$+25^{\circ}C$			1	μA	
Line Regulation		$2.8V \leq V_{IN} \leq 5.5V$, $I_{LOAD} = 4.5mA$	$+25^{\circ}C$		0.1		%	
Load Regulation		$0 \leq I_{LOAD} \leq 4.5mA$	$+25^{\circ}C$		0.05		%	
Soft-Start Duration			$+25^{\circ}C$		4		ms	
Control Input (CNTRL)								
Maximum Control Input Voltage		FB set point is controlled to V_{CNTRL}	$+25^{\circ}C$		1.2		V	
CNTRL-to-REF Transition Threshold		$V_{FB} = V_{REF}$ above this voltage	$+25^{\circ}C$		1.3		V	
CNTRL Input-Bias Current		$V_{CNTRL} = V_{FB_SET}$	$+25^{\circ}C$			400	nA	
Current Monitor								
Bias Voltage Range	V_{BIAS}		Full	10		70	V	
Bias Quiescent Current	I_{BIAS}	$I_{APD} = 500nA$	SGM41285A	Full		220	280	μA
			SGM41285B	Full		220	280	
		$I_{APD} = 2mA$	SGM41285A	Full		4	4.7	mA
			SGM41285B	Full		2	3	
Voltage Drop	V_{DROP}	$I_{APD} = 2mA$, $V_{DROP} = V_{BIAS} - V_{APD}$	Full		1.9	2.3	V	
Dynamic Output Resistance at MOUT	R_{MOUT}	$R_{MOUT} = \Delta V_{MOUT} / \Delta I_{MOUT}$, $I_{APD} = 2.5mA$	$+25^{\circ}C$		5		G Ω	
APD Current-Step Response		Step load on $I_{APD} = 20\mu A$ to 1mA	$+25^{\circ}C$		50		ns	
MOUT Output Leakage		APD is unconnected	$+25^{\circ}C$		1	400	nA	
Output Clamp Voltage	$V_{MOUT} - V_{CLAMP}$	Forward diode current = 500 μA	Full	0.8	0.95	1.1	V	

70V, 300mW Boost Converter and Current Monitor for APD Bias Applications

SGM41285

ELECTRICAL CHARACTERISTICS (continued)

($V_{IN} = V_{nSHDN} = V_{CNTRL} = 3.3V$, $V_{BIAS} = 40V$, $V_{MOUT} = 0V$, $V_{PGND} = V_{SGND} = 0V$, $C_{IN} = 1\mu F$, $SW = APD = CLAMP = nLIM =$ unconnected, Full = $-40^{\circ}C$ to $+125^{\circ}C$, typical values are at $T_A = +25^{\circ}C$, unless otherwise noted.)

PARAMETER	SYMBOL	CONDITIONS	TEMP	MIN	TYP	MAX	UNITS	
Current Gain	I_{MOUT}/I_{APD}	$I_{APD} = 500nA$	SGM41285A	Full	0.965	1.05	1.170	mA/mA
			SGM41285B	Full	0.172	0.2	0.225	
		$I_{APD} = 2mA$	SGM41285A	Full	0.985	1	1.025	
			SGM41285B	Full	0.195	0.2	0.204	
Power-Supply Rejection Ratio	PSRR	$(\Delta I_{MOUT}/I_{MOUT})/\Delta V_{BIAS}$, $V_{BIAS} = 10V$ to $70V$ and $I_{APD} = 5\mu A$ to $1mA$	SGM41285A	$+25^{\circ}C$		30		ppm/V
			SGM41285B	$+25^{\circ}C$		30		
APD Input Current Limit	I_{LIM_APD}		Full	3.95	4.5	5.05	mA	
Logic I/O								
nSHDN Input Voltage Low	V_{IL}		Full			0.3	V	
nSHDN Input Voltage High	V_{IH}		Full	1.5			V	
nLIM Output Voltage Low	V_{OL}	$I_{LIM} = 2mA$	Full			200	mV	
nLIM Output Leakage Current	I_{OH}		$+25^{\circ}C$			1	μA	
Thermal Protection								
Thermal Shutdown	T_{SHDN}				170		$^{\circ}C$	
Thermal Shutdown Hysteresis	T_{HYS}				20		$^{\circ}C$	

TYPICAL PERFORMANCE CHARACTERISTICS

$V_{IN} = 3.3V$, $V_{OUT} = 70V$, $T_A = +25^\circ C$, unless otherwise noted.

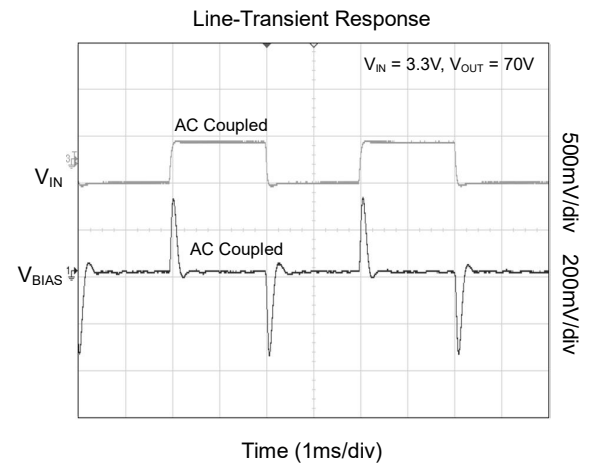
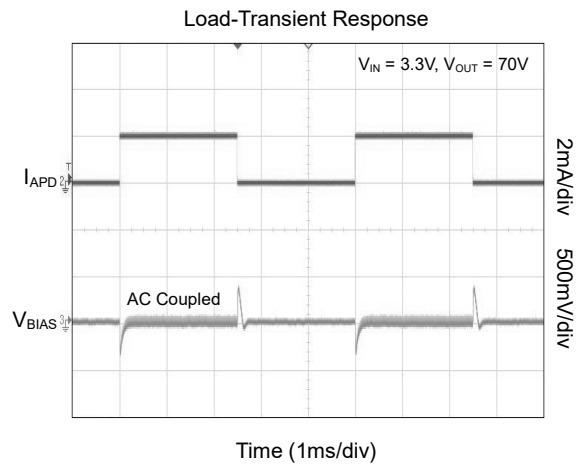
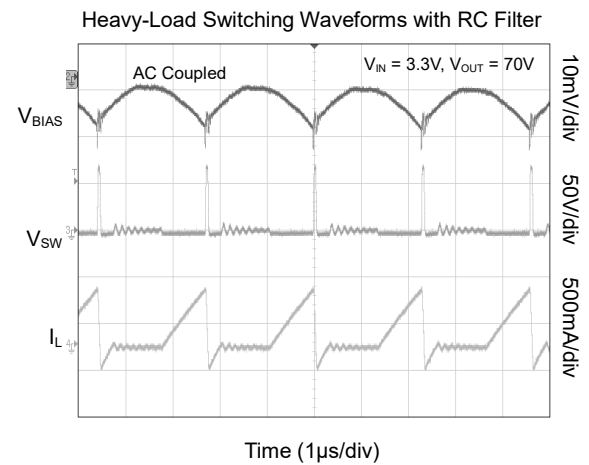
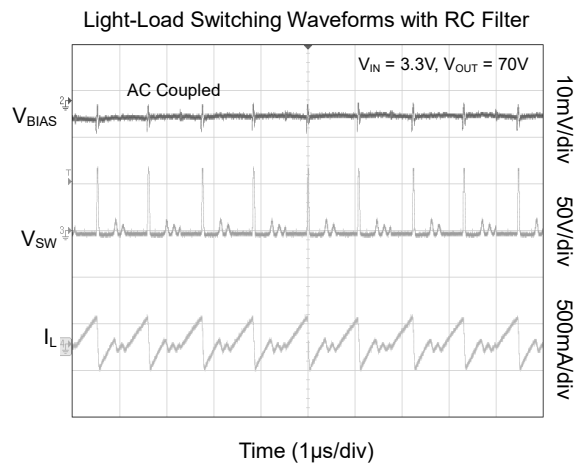
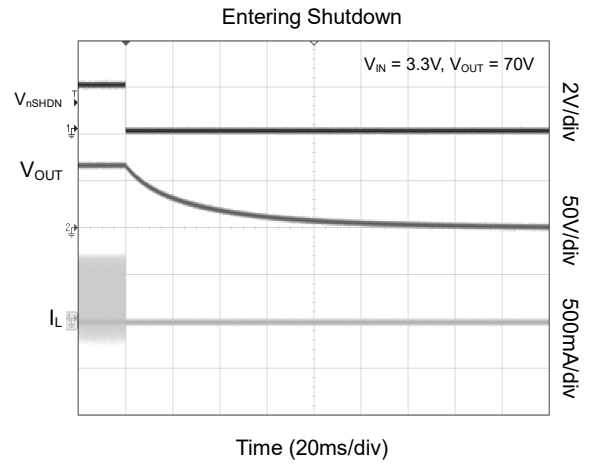
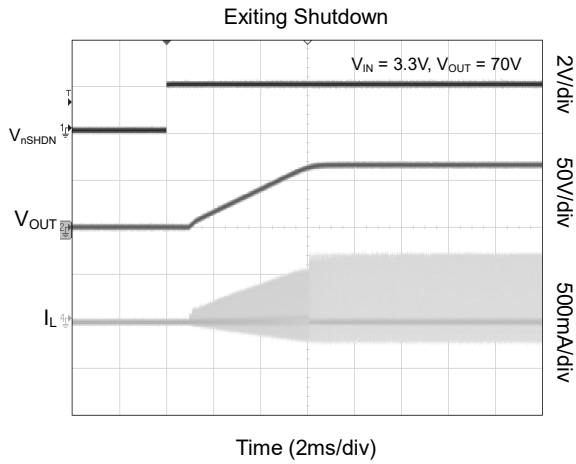

TYPICAL PERFORMANCE CHARACTERISTICS (continued)

$V_{IN} = 3.3V$, $V_{OUT} = 70V$, $T_A = +25^\circ C$, unless otherwise noted.

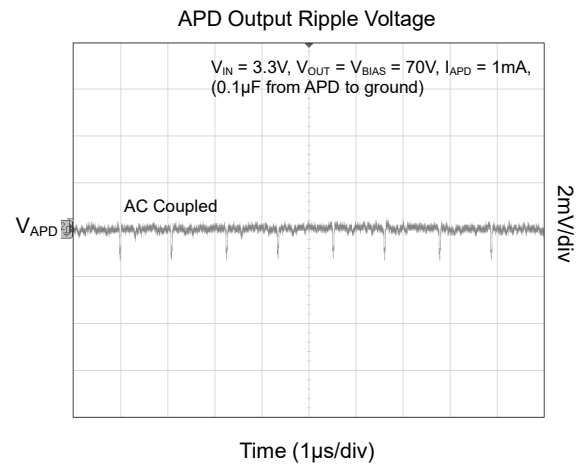
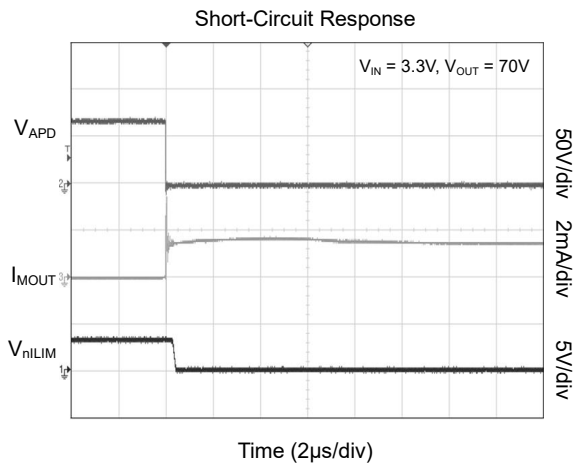
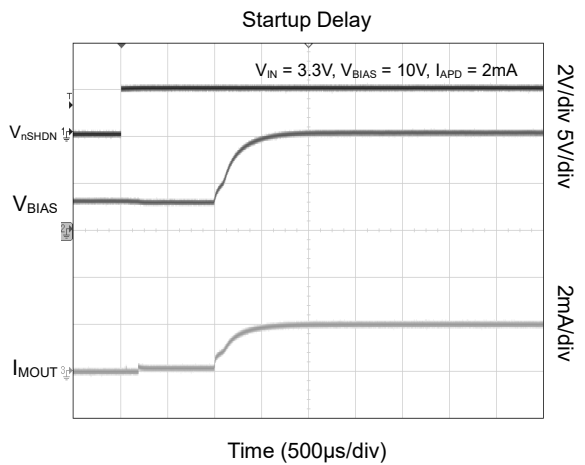
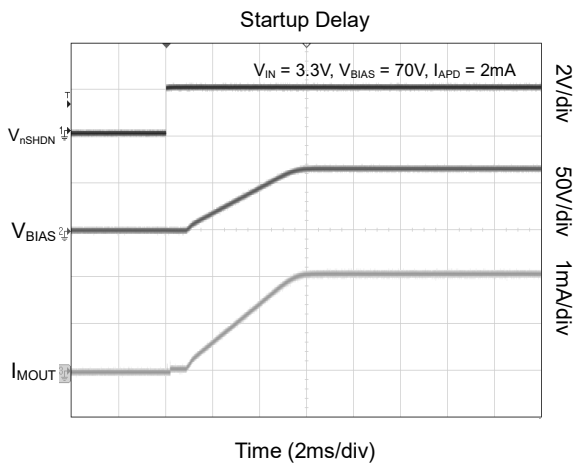
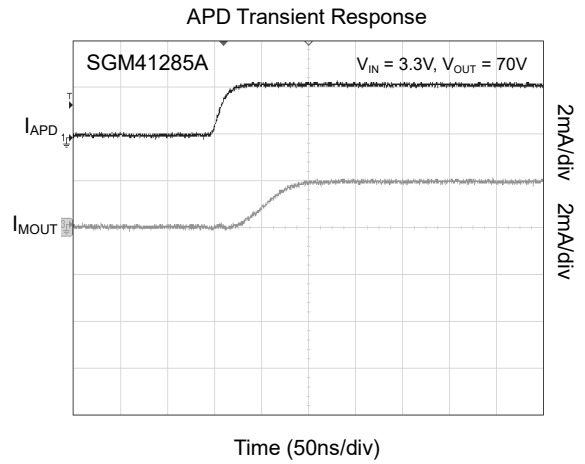
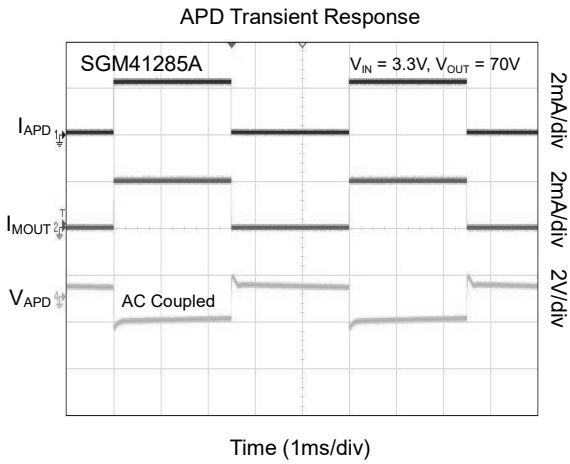

TYPICAL PERFORMANCE CHARACTERISTICS (continued)

$V_{IN} = 3.3V$, $V_{OUT} = 70V$, $T_A = +25^{\circ}C$, unless otherwise noted.

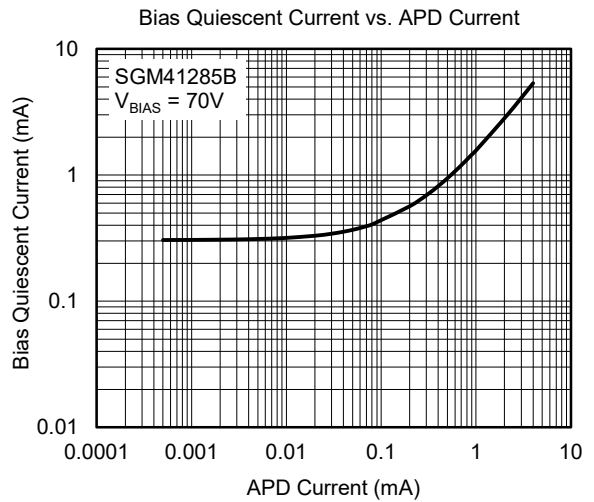
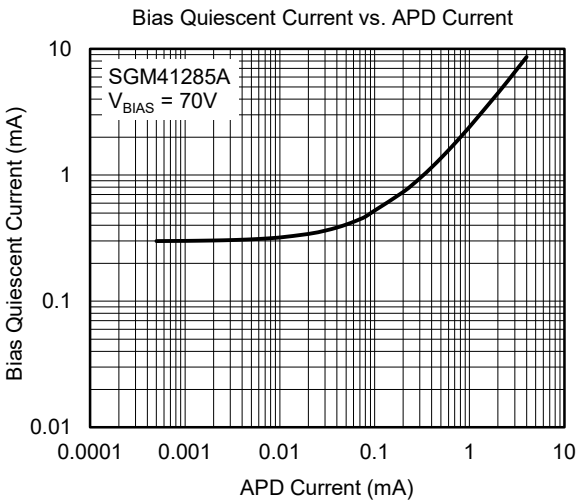
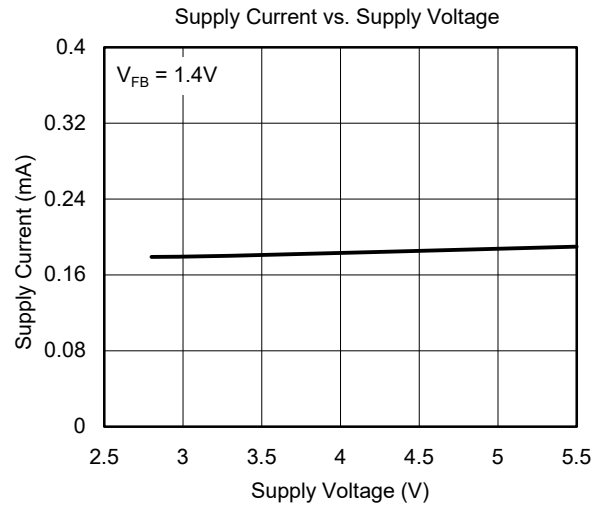
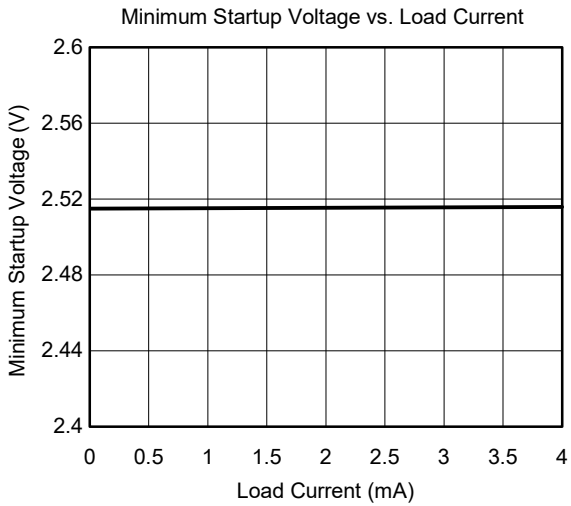
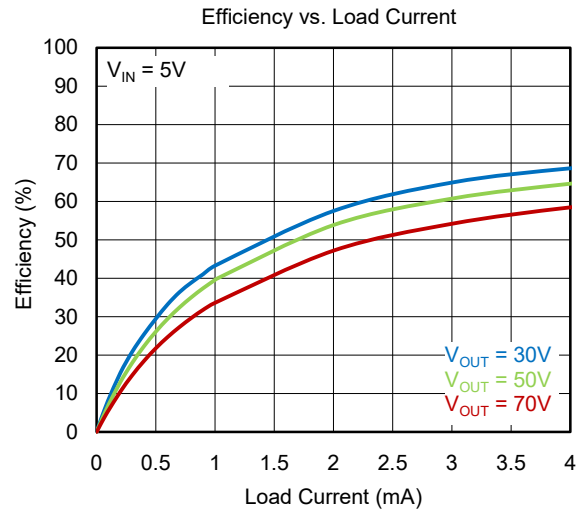
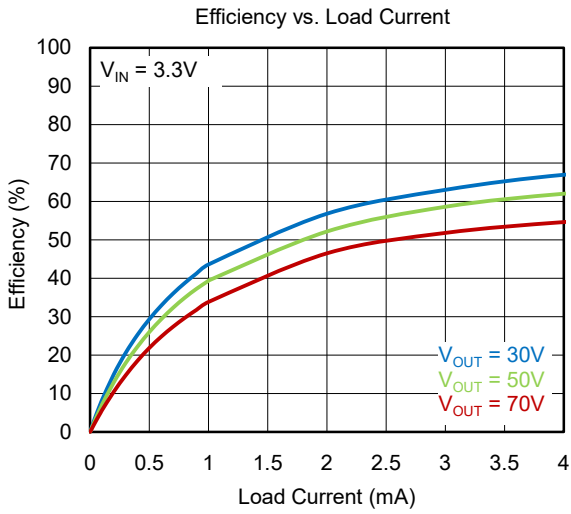

SGM41285 70V, 300mW Boost Converter and Current Monitor for APD Bias Applications

TYPICAL PERFORMANCE CHARACTERISTICS (continued)

$V_{IN} = 3.3V$, $V_{OUT} = 70V$, $T_A = +25^\circ C$, unless otherwise noted.

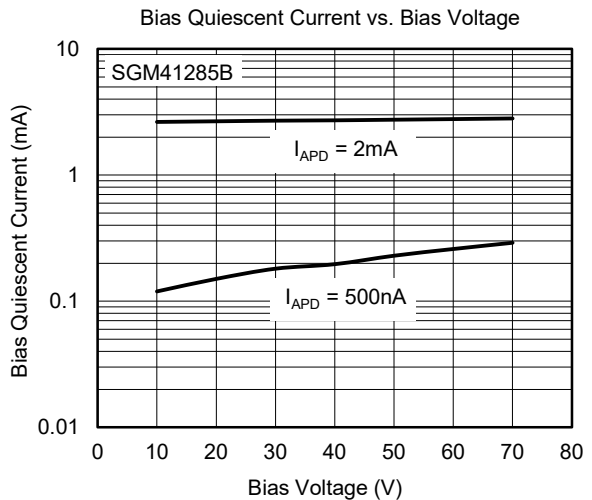
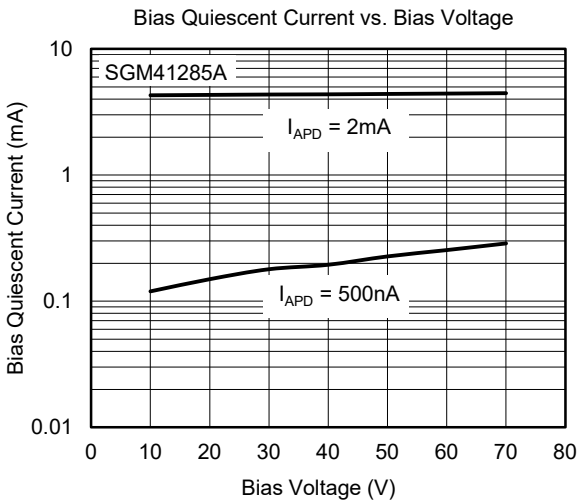
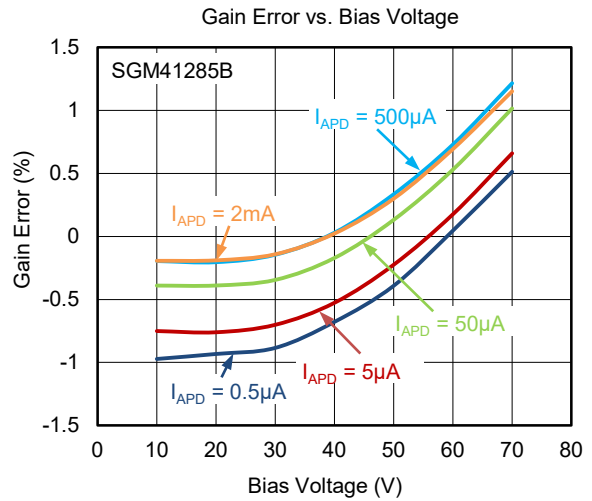
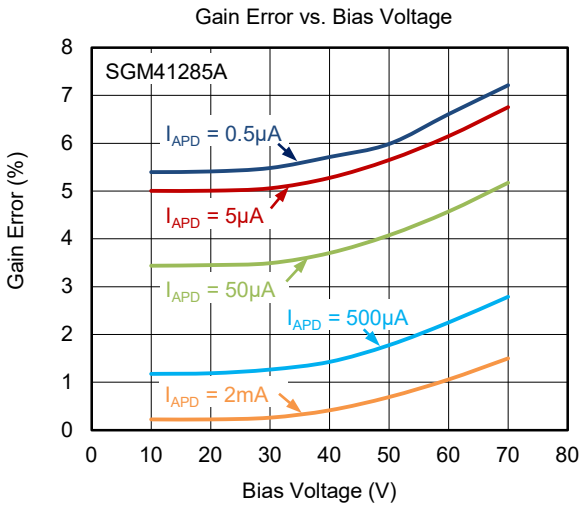
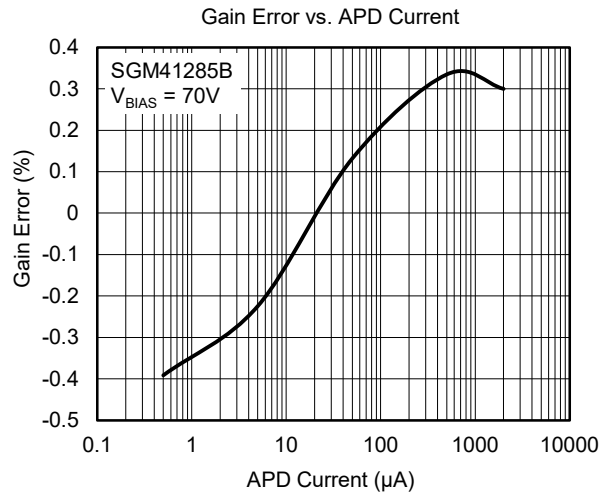
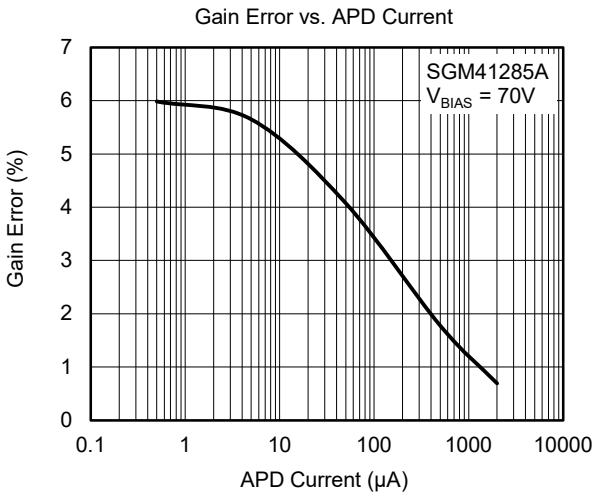

SGM41285 70V, 300mW Boost Converter and Current Monitor for APD Bias Applications

TYPICAL PERFORMANCE CHARACTERISTICS (continued)

$V_{IN} = 3.3V$, $V_{OUT} = 70V$, $T_A = +25^\circ C$, unless otherwise noted.

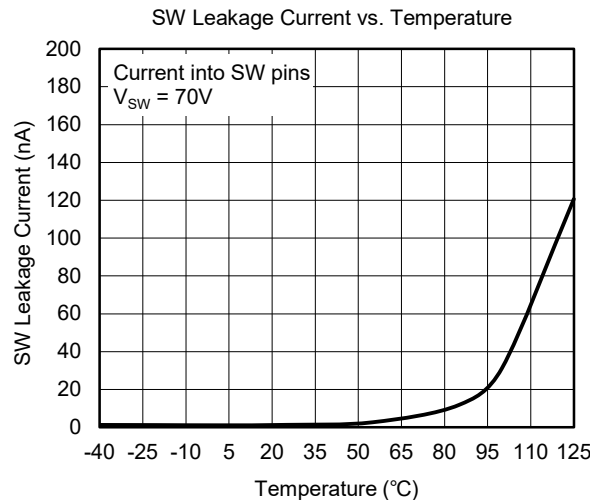
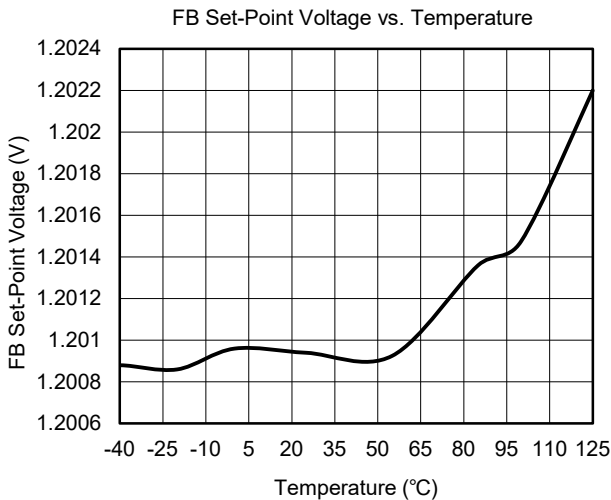
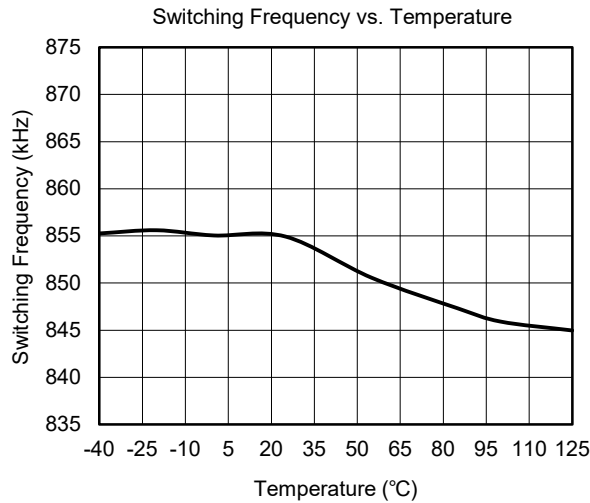
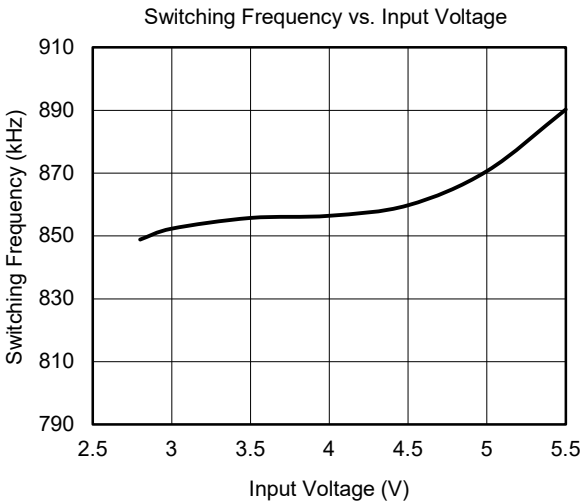
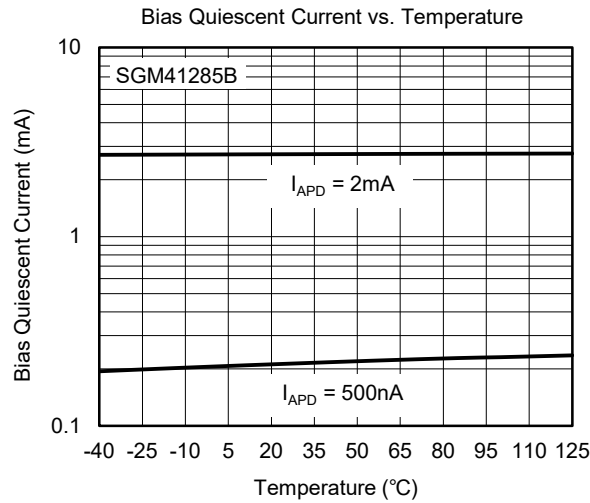
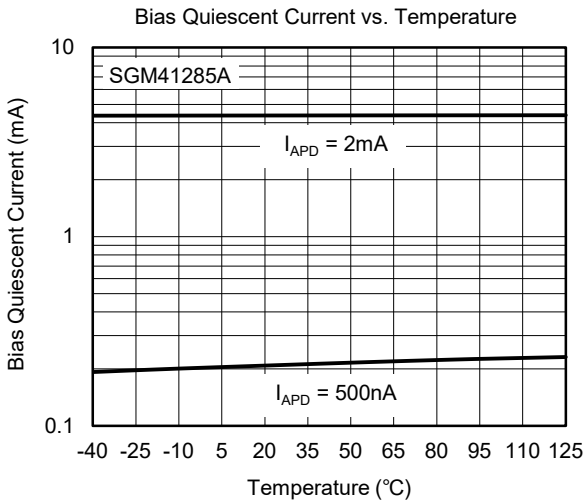

TYPICAL PERFORMANCE CHARACTERISTICS (continued)

$V_{IN} = 3.3V$, $V_{OUT} = 70V$, $T_A = +25^{\circ}C$, unless otherwise noted.

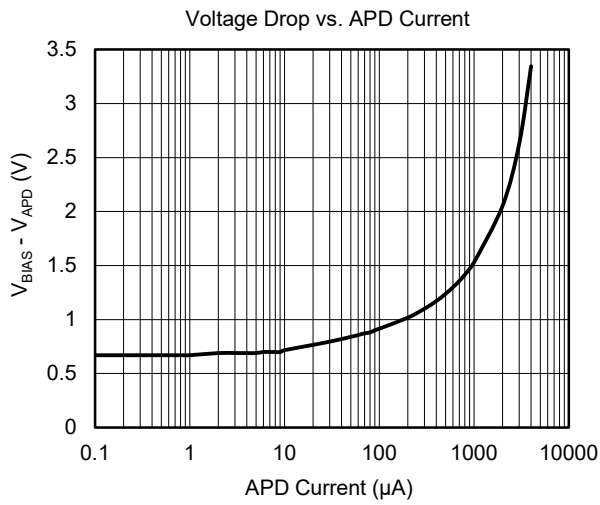

REVISION HISTORY

NOTE: Page numbers for previous revisions may differ from page numbers in the current version.

	Page
<hr/>	
NOVEMBER 2020 – REV.A.1 to REV.A.2	
Updated Marking Information section.....	2
<hr/>	
JANUARY 2019 – REV.A to REV.A.1	
Updated operating temperature range and Electrical Characteristics	4-5
<hr/>	
Changes from Original (DECEMBER 2018) to REV.A	
Changed from product preview to production data.....	All
<hr/>	

PACKAGE INFORMATION

PACKAGE OUTLINE DIMENSIONS

TQFN-3×3-16L

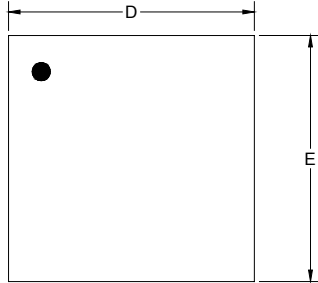

TOP VIEW

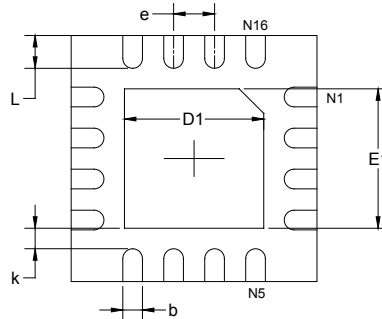

BOTTOM VIEW

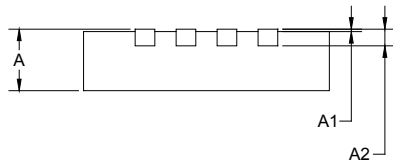

SIDE VIEW

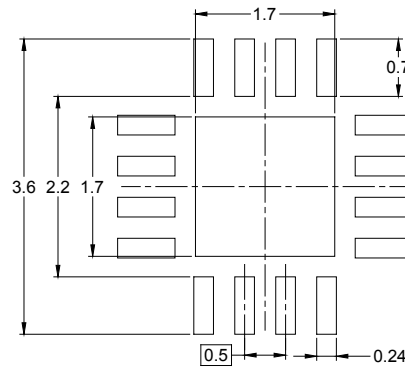

RECOMMENDED LAND PATTERN (Unit: mm)

Symbol	Dimensions In Millimeters		Dimensions In Inches	
	MIN	MAX	MIN	MAX
A	0.700	0.800	0.028	0.031
A1	0.000	0.050	0.000	0.002
A2	0.203 REF		0.008 REF	
D	2.900	3.100	0.114	0.122
D1	1.600	1.800	0.063	0.071
E	2.900	3.100	0.114	0.122
E1	1.600	1.800	0.063	0.071
k	0.200 MIN		0.008 MIN	
b	0.180	0.300	0.007	0.012
e	0.500 TYP		0.020 TYP	
L	0.300	0.500	0.012	0.020

PACKAGE INFORMATION

TAPE AND REEL INFORMATION

REEL DIMENSIONS

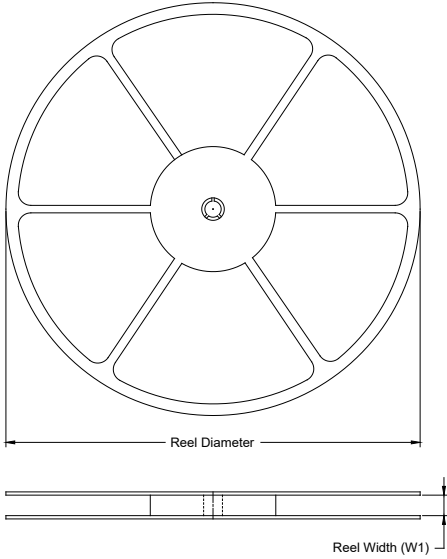

TAPE DIMENSIONS

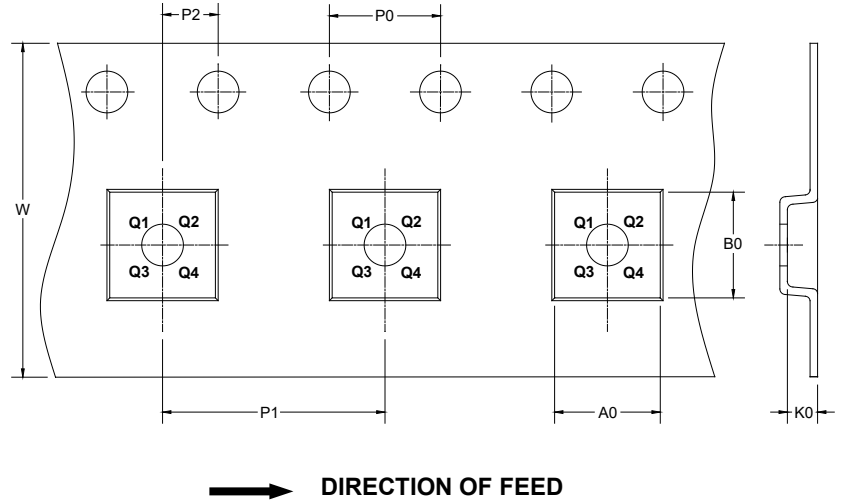

NOTE: The picture is only for reference. Please make the object as the standard.

KEY PARAMETER LIST OF TAPE AND REEL

Package Type	Reel Diameter	Reel Width W1 (mm)	A0 (mm)	B0 (mm)	K0 (mm)	P0 (mm)	P1 (mm)	P2 (mm)	W (mm)	Pin1 Quadrant
TQFN-3×3-16L	13"	12.4	3.35	3.35	1.13	4.0	8.0	2.0	12.0	Q2

000001

PACKAGE INFORMATION

CARTON BOX DIMENSIONS



NOTE: The picture is only for reference. Please make the object as the standard.

KEY PARAMETER LIST OF CARTON BOX

Reel Type	Length (mm)	Width (mm)	Height (mm)	Pizza/Carton
13"	386	280	370	5

DD0002

单击下面可查看定价，库存，交付和生命周期等信息

[>>SGMICRO\(圣邦微电子\)](#)