

GENERAL DESCRIPTION

The SGM3736 is a high efficiency constant current LED driver with a 1.1MHz PWM boost converter. An internal low-side N-channel MOSFET and a high switching frequency make the SGM3736 easy to use small components and optimized for compact solutions.

The SGM3736 is capable of driving either up to 10 LEDs in series for 38V output or total 260mA current with 3 LEDs in series per string while achieving high conversion efficiency. The LED current can be programmed by digital PWM dimming interface. The PWM frequency is in the range from 2kHz to 60kHz.

The SGM3736 provides very low shutdown current. It also includes a comprehensive set of protection features such as over-voltage protection, cycle-by-cycle input current limit and thermal shutdown.

The SGM3736 is available in a Green TDFN-2×2-8L package. It operates over an ambient temperature range of -40°C to +85°C.

FEATURES

- **Input Voltage Range: 2.7V to 5.5V**
- **Support up to 10 LEDs in Series**
- **Integrated 40V/1.35A Switch**
- **High Efficiency PWM Boost Converter**
- **Switching Frequency: 1.1MHz**
- **Low Feedback Voltage: 200mV**
- **PWM Dimming Frequency: 2kHz to 60kHz**
- **38V LED Open Protection**
- **500kΩ Pull-Down Resistor on EN/PWM Pin**
- **Automatic Soft-Start for Reducing Inrush Current**
- **Less than 1μA Shutdown Current**
- **Available in a Green TDFN-2×2-8L Package**
- **-40°C to +85°C Operating Temperature Range**

APPLICATIONS

LED Backlighting
Mobile Phones and Digital Photo Frames
Portable Devices
Automotive Navigation

PACKAGE/ORDERING INFORMATION

MODEL	PACKAGE DESCRIPTION	SPECIFIED TEMPERATURE RANGE	ORDERING NUMBER	PACKAGE MARKING	PACKING OPTION
SGM3736	TDFN-2x2-8L	-40°C to +85°C	SGM3736YTDE8G/TR	3736 XXXX	Tape and Reel, 3000

MARKING INFORMATION

NOTE: XXXX = Date Code.

XXXX

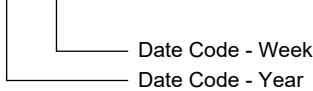

Green (RoHS & HSF): SG Micro Corp defines "Green" to mean Pb-Free (RoHS compatible) and free of halogen substances. If you have additional comments or questions, please contact your SGMICRO representative directly.

ABSOLUTE MAXIMUM RATINGS

- Input Voltage, V_{IN} -0.3V to 6V
- High Voltage Nodes, SW, VOUT -0.3V to 40V
- Other Pins, FB, EN/PWM.....-0.3V to $V_{IN} + 0.3V$
- Package Thermal Resistance
- TDFN-2x2-8L, θ_{JA} 75°C/W
- Junction Temperature..... 150°C
- Storage Temperature Range-65°C to +150°C
- Lead Temperature (Soldering, 10s).....260°C
- ESD Susceptibility
- HBM..... 3000V
- MM..... 200V

RECOMMENDED OPERATING CONDITIONS

- Input Voltage Range2.7V to 5.5V
- Operating Temperature Range-40°C to +85°C

OVERSTRESS CAUTION

Stresses beyond those listed in Absolute Maximum Ratings may cause permanent damage to the device. Exposure to absolute maximum rating conditions for extended periods may affect reliability. Functional operation of the device at any conditions beyond those indicated in the Recommended Operating Conditions section is not implied.

ESD SENSITIVITY CAUTION

This integrated circuit can be damaged if ESD protections are not considered carefully. SGMICRO recommends that all integrated circuits be handled with appropriate precautions. Failure to observe proper handling and installation procedures can cause damage. ESD damage can range from subtle performance degradation to complete device failure. Precision integrated circuits may be more susceptible to damage because even small parametric changes could cause the device not to meet the published specifications.

DISCLAIMER

SG Micro Corp reserves the right to make any change in circuit design, or specifications without prior notice.

PIN CONFIGURATION

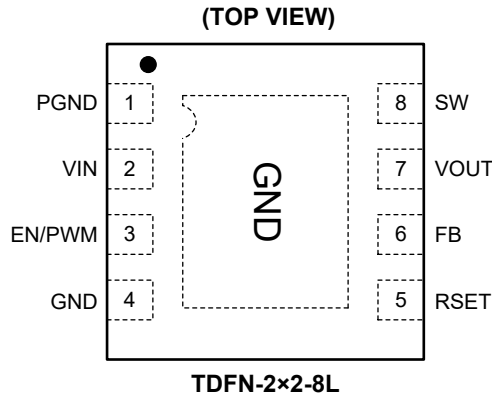

PIN DESCRIPTION

PIN	NAME	FUNCTION
1	PGND	Power Ground Pin.
2	VIN	Input Supply Pin.
3	EN/PWM	Enable Control and PWM Dimming Input. It is used for enable and PWM dimming control.
4	GND	Ground Pin.
5	RSET	Current Setting Pin. Connect an external resistor from RSET pin to ground to program the maximum white LED current.
6	FB	Feedback Input for Current. It is regulated at 200mV.
7	VOUT	Output Voltage Pin.
8	SW	Boost Converter Switching Node.
Exposed Pad	GND	Exposed Pad. It should be soldered to PCB board and connected to GND.

TYPICAL APPLICATION

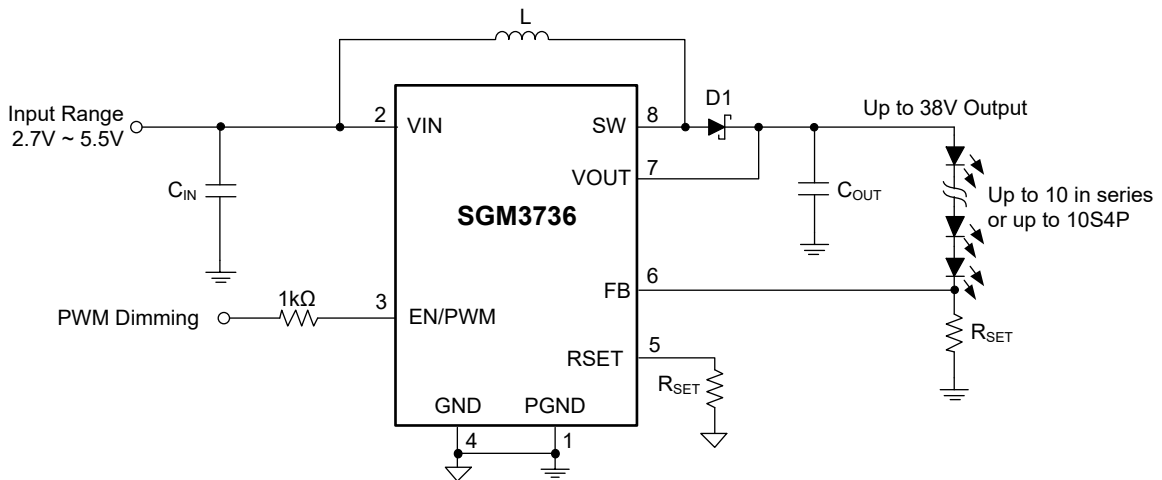

Figure 1. Typical Application Circuit

ELECTRICAL CHARACTERISTICS ⁽¹⁾

($V_{IN} = 3.6V$, $L = 10\mu H$, $C_{IN} = 10\mu F$, $C_{OUT} = 0.47\mu F$, Full = $-40^{\circ}C$ to $+85^{\circ}C$, typical values are at $T_A = +25^{\circ}C$, unless otherwise noted.)

PARAMETER	SYMBOL	CONDITIONS	TEMP	MIN	TYP	MAX	UNITS
IC Supply							
Input Voltage Range	V_{IN}		Full	2.7		5.5	V
Input Under-Voltage Lockout	UVLO	Rising edge	$+25^{\circ}C$		2.5	2.6	V
UVLO Hysteresis	V_{HYS}		$+25^{\circ}C$		0.15		V
Quiescent Current (Non Switching)	I_Q	$V_{FB} = 0.4V$	$+25^{\circ}C$		0.20	0.35	mA
Operating Current (Switching)		$V_{FB} = 0V$	$+25^{\circ}C$		0.72	1.5	mA
VIN Pin Shutdown Current	I_{SHDN}	$V_{EN} = 0V$	$+25^{\circ}C$		0.1	1	μA
Step-Up Converter							
Voltage Feedback Regulation Voltage	V_{REF}		Full	192	200	212.5	mV
Voltage Feedback Regulation Voltage Under Brightness Control	V_{REF_PWM}	$f_{PWM} = 10kHz$, duty cycle = 3%	$+25^{\circ}C$	3.5	6	8.5	mV
V_{REF} Filter 3dB Frequency	$f_{REF(3dB)}$		$+25^{\circ}C$		600		Hz
SW Pin Leakage Current	I_{SW}		$+25^{\circ}C$		0.01	1	μA
Peak NMOS Current Limit	I_{LIM}		$+25^{\circ}C$		1.35		A
Oscillator Frequency	f_S		Full	0.90	1.10	1.4	MHz
Over-Voltage Threshold	V_{OVP}	Measured at VOUT pin	Full	35.5	38.0	40.5	V
Start-Up Time	t_S		$+25^{\circ}C$		800		μs
Control							
Logic Low Threshold	V_{IL}		Full			0.35	V
Logic High Threshold	V_{IH}		Full	1.5			V
PWM Dimming Frequency Range	DFR		$+25^{\circ}C$	2		60	kHz
Minimum Shutdown Pulse Width Timing	t_{OFF}		$+25^{\circ}C$	3			ms
Junction Thermal Shutdown Threshold					150		$^{\circ}C$
Junction Thermal Shutdown Hysteresis					15		$^{\circ}C$

NOTE:

1. The SGM3736 is guaranteed to meet performance specifications over the $-40^{\circ}C$ to $+85^{\circ}C$ operating temperature range by design, characterization and correlation with statistical process controls.

RECOMMENDED COMPONENTS OF TEST CIRCUITS

	Component		Component
Inductor	22 μ H/CD75NP-220KC	Capacitor	10 μ F/C2012X7R1H106KT
	10 μ H/CD75NP-100KC		0.47 μ F/C2012X7R1H474KT
Diode	MBR0540		

TYPICAL PERFORMANCE CHARACTERISTICS

T_A = +25°C, L = 10 μ H, C_{IN} = 10 μ F, C_{OUT} = 0.47 μ F, unless otherwise noted.

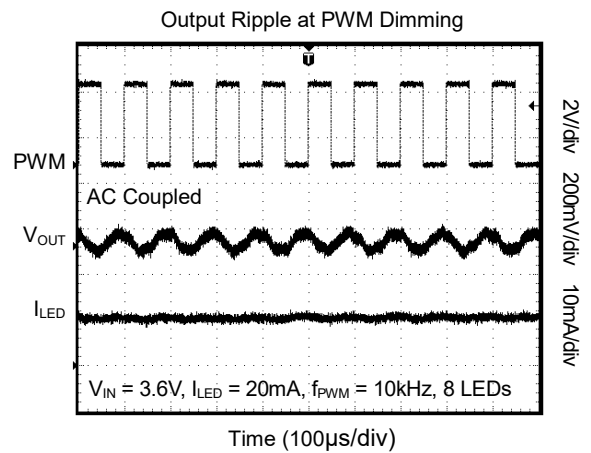
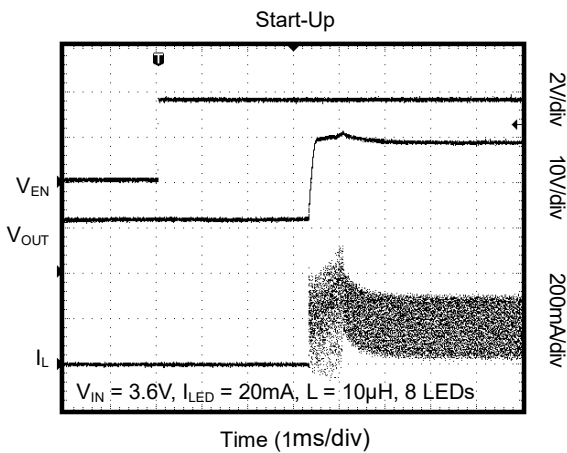
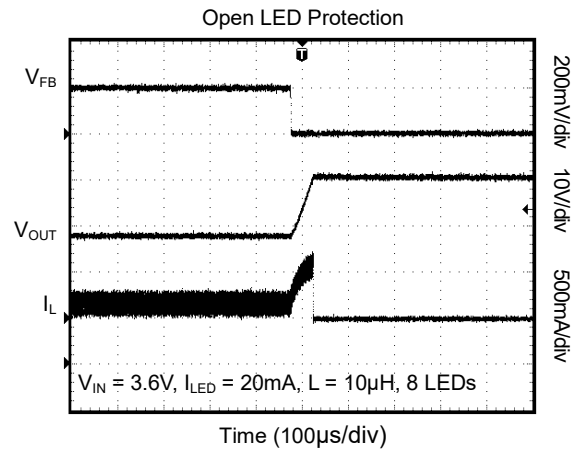
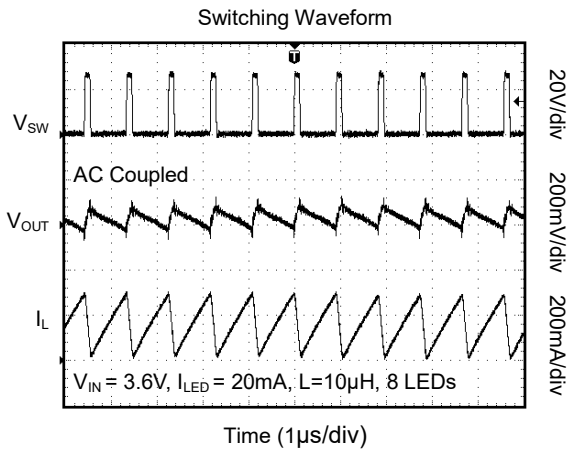

TYPICAL PERFORMANCE CHARACTERISTICS (continued)

T_A = +25°C, L = 10µH, C_{IN} = 10µF, C_{OUT} = 0.47µF, unless otherwise noted.

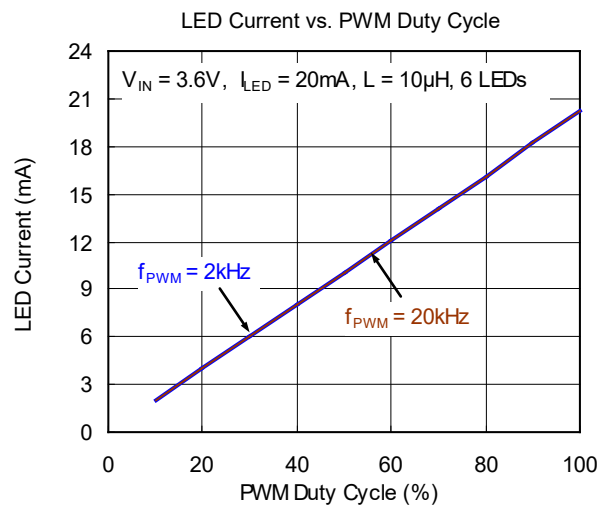
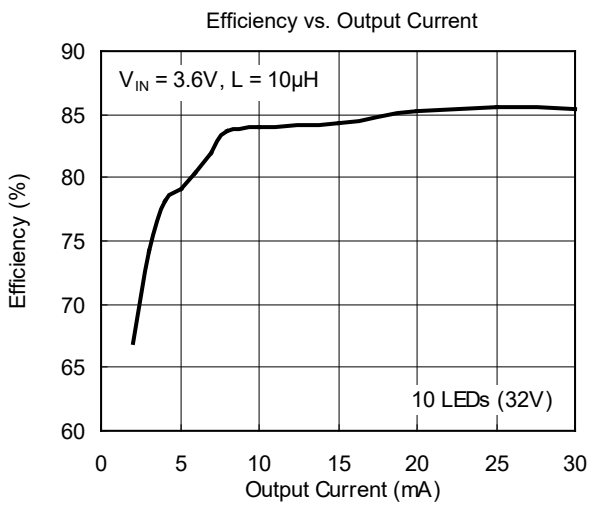
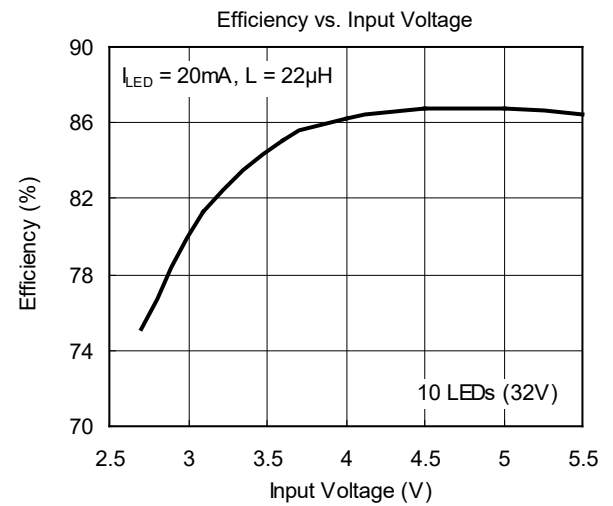
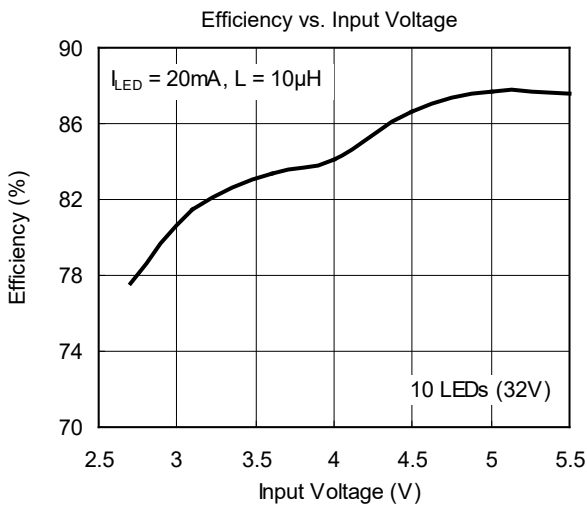
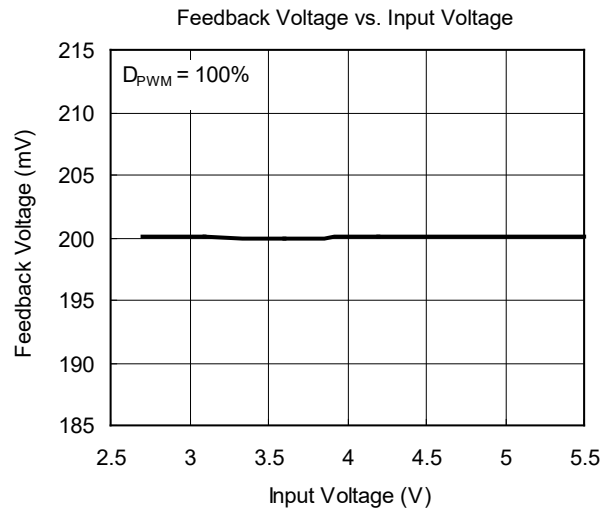
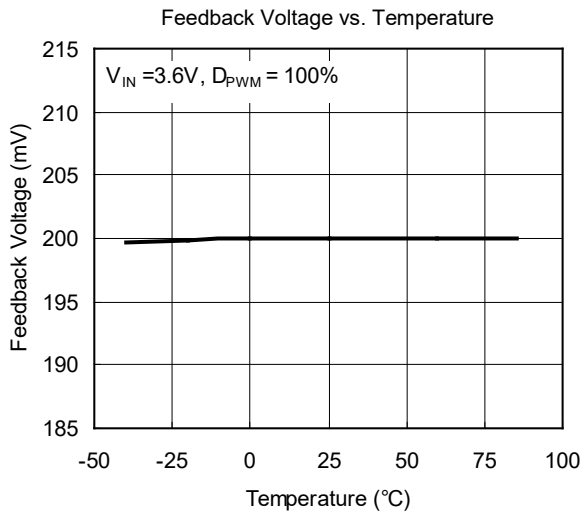

REVISION HISTORY

NOTE: Page numbers for previous revisions may differ from page numbers in the current version.

SEPTEMBER 2021 – REV.A.3 to REV.A.4		Page
Changed Ordering Information section		2
Changed Package Outline Dimensions section		10
JUNE 2015 – REV.A.2 to REV.A.3		Page
Changed Ordering Number.....		2
FEBRUARY 2015 – REV.A.1 to REV.A.2		Page
New version.....		All
JULY 2014 – REV.A to REV.A.1		Page
Changed General Description section.....		1
Changed LED Maximum Current Setting		9
Changed Capacitor Selection section		9
Changed Figure 1.....		9
Changes from Original (APRIL 2014) to REV.A		Page
Changed from product preview to production data.....		All

PACKAGE OUTLINE DIMENSIONS

TDFN-2x2-8L

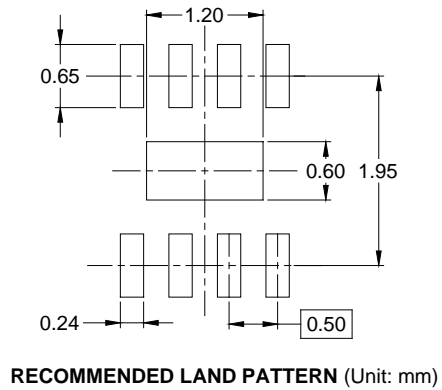
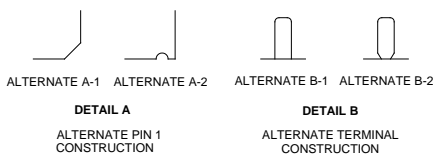
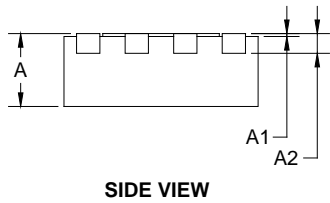
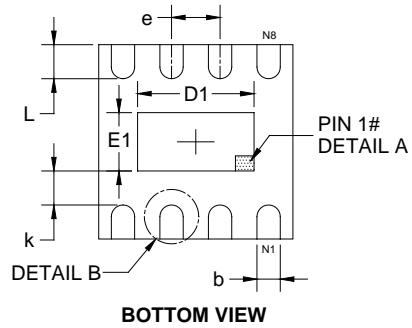
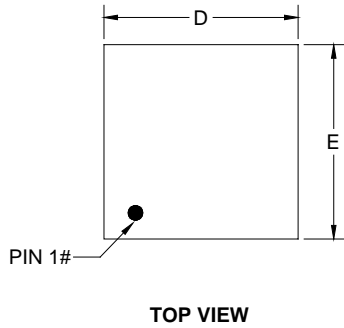

Symbol	Dimensions In Millimeters		
	MIN	MOD	MAX
A	0.700	0.750	0.800
A1	0.000	-	0.050
A2	0.203 REF		
D	1.900	2.000	2.100
E	1.900	2.000	2.100
D1	1.100	1.200	1.300
E1	0.500	0.600	0.700
b	0.180	-	0.300
e	0.500 TYP		
k	0.200 MIN		
L	0.250	0.350	0.450

NOTE: This drawing is subject to change without notice.

TAPE AND REEL INFORMATION

REEL DIMENSIONS

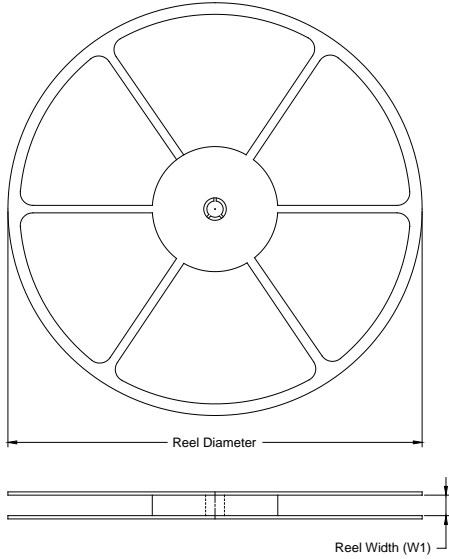

TAPE DIMENSIONS

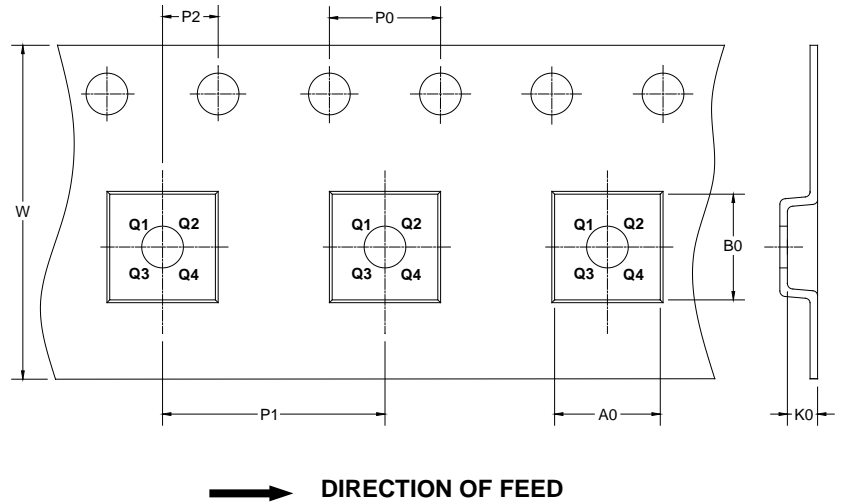

NOTE: The picture is only for reference. Please make the object as the standard.

KEY PARAMETER LIST OF TAPE AND REEL

Package Type	Reel Diameter	Reel Width W1 (mm)	A0 (mm)	B0 (mm)	K0 (mm)	P0 (mm)	P1 (mm)	P2 (mm)	W (mm)	Pin1 Quadrant
TDFN-2x2-8L	7"	9.5	2.30	2.30	1.10	4.0	4.0	2.0	8.0	Q1

1000001

PACKAGE INFORMATION

CARTON BOX DIMENSIONS



NOTE: The picture is only for reference. Please make the object as the standard.

KEY PARAMETER LIST OF CARTON BOX

Reel Type	Length (mm)	Width (mm)	Height (mm)	Pizza/Carton
7" (Option)	368	227	224	8
7"	442	410	224	18

DD0002

单击下面可查看定价，库存，交付和生命周期等信息

[>>SGMICRO\(圣邦微电子\)](#)