



SGM4T245

4-Bit Dual-Supply Bus Transceiver with Configurable Voltage Translation and 3-State Outputs

GENERAL DESCRIPTION

This 4-bit non-inverting bus transceiver uses two separate configurable power-supply rails. The SGM4T245 is optimized to operate with V_{CCA}/V_{CCB} set at 1.2V to 5.0V. The A port is designed to track V_{CCA} . V_{CCA} accepts any supply voltage from 1.2V to 5.0V. The B port is designed to track V_{CCB} . V_{CCB} accepts any supply voltage from 1.2V to 5.0V. This allows for universal low-voltage bidirectional translation between any of the 1.2V, 1.5V, 1.8V, 2.5V, 3.3V and 5.0V voltage nodes.

The SGM4T245 is designed for asynchronous communication between data buses. The device transmits data from the A bus to the B bus or from the B bus to the A bus, depending on the logic level at the direction-control (DIR) input. The output-enable (\overline{OE}) input can be used to disable the outputs so the buses are effectively isolated.

This device is fully specified for partial-power-down applications using I_{OFF} . The I_{OFF} circuitry disables the outputs, thus preventing damaging current backflow through the device when it is powered down.

To ensure the high-impedance state during power up or power down, \overline{OE} shall be tied to V_{CC} through a pull-up resistor; the minimum value of the resistor is determined by the current-sinking capability of the driver.

The SGM4T245 is available in Green TSSOP-16 and TQFN-2.6×1.8-16L packages. It operates over an ambient temperature range of -40°C to +125°C.

FEATURES

- Control Inputs V_{IH}/V_{IL} Levels are Referenced to V_{CCA} Voltage
- V_{CC} Isolation: If Either V_{CC} Input is at GND, All I/O Ports are in the High-Impedance State
- I_{OFF} : Supports Partial Power-Down Mode Operation
- Fully Configurable Dual-Rail Design Allows Each Port to Operate Over the Full 1.2V to 5.0V Power-Supply Range
- I/Os are 6.0V Tolerant
- -40°C to +125°C Operating Temperature Range
- Available in Green TSSOP-16 and TQFN-2.6×1.8-16L Packages

APPLICATIONS

Personal Electronic
Industrial
Enterprise
Telecom

LOGIC DIAGRAM

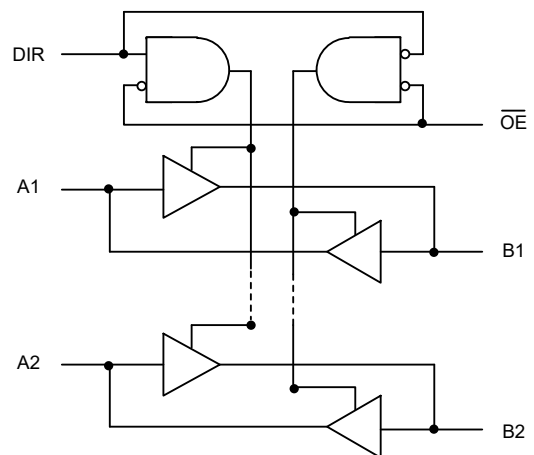

NOTE: Positive logic for 1/2 of SGM4T245.

4-Bit Dual-Supply Bus Transceiver with SGM4T245 Configurable Voltage Translation and 3-State Outputs

PACKAGE/ORDERING INFORMATION

MODEL	PACKAGE DESCRIPTION	SPECIFIED TEMPERATURE RANGE	ORDERING NUMBER	PACKAGE MARKING	PACKING OPTION
SGM4T245	TSSOP-16	-40°C to +125°C	SGM4T245XTS16G/TR	SGM4T245 XTS16 XXXXX	Tape and Reel, 4000
	TQFN-2.6×1.8-16L	-40°C to +125°C	SGM4T245XTQA16G/TR	4T245 XXXXX	Tape and Reel, 3000

MARKING INFORMATION

NOTE: XXXXX = Date Code and Vendor Code.

XXXXX

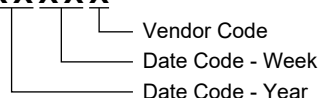

Green (RoHS & HSF): SG Micro Corp defines "Green" to mean Pb-Free (RoHS compatible) and free of halogen substances. If you have additional comments or questions, please contact your SGMICRO representative directly.

ABSOLUTE MAXIMUM RATINGS

Supply Voltage Range

V_{CCA} -0.3V to 6.0V

V_{CCB} -0.3V to 6.0V

Input Voltage Range, $V_I^{(1)}$

A Ports -0.3V to 6.0V

B Ports -0.3V to 6.0V

Control Inputs -0.3V to 6.0V

Voltage Range Applied to Any Output in the High- Impedance or Power-Off State, $V_O^{(1)}$

A Ports -0.3V to 6.0V

B Ports -0.3V to 6.0V

Voltage Range Applied to Any Output in the High or Low State, $V_O^{(1)(2)}$

A Ports -0.3V to $V_{CCA} + 0.3V$

B Ports -0.3V to $V_{CCB} + 0.3V$

Input Clamp Current, $I_{IK} (V_I < 0)$ -70mA (MAX)

Output Clamp Current, $I_{OK} (V_O < 0)$ -70mA (MAX)

Continuous Output Current, I_O -70mA to 70mA

Continuous Output Current through V_{CCA} , V_{CCB} , or GND, I_O -100mA to 100mA

Junction Temperature +150°C

Storage Temperature Range -65°C to +150°C

Lead Temperature (Soldering, 10s) +260°C

ESD Susceptibility

HBM 6000V

MM 400V

CDM 1000V

NOTES:

1. The input voltage and output negative-voltage ratings may be exceeded if the input and output current ratings are observed.

2. The output positive-voltage rating may be exceeded up to 6.0V maximum if the output current rating is observed.

OVERSTRESS CAUTION

Stresses beyond those listed in Absolute Maximum Ratings may cause permanent damage to the device. Exposure to absolute maximum rating conditions for extended periods may affect reliability. Functional operation of the device at any conditions beyond those indicated in the Recommended Operating Conditions section is not implied.

ESD SENSITIVITY CAUTION

This integrated circuit can be damaged by ESD if you don't pay attention to ESD protection. SGMICRO recommends that all integrated circuits be handled with appropriate precautions. Failure to observe proper handling and installation procedures can cause damage. ESD damage can range from subtle performance degradation to complete device failure. Precision integrated circuits may be more susceptible to damage because very small parametric changes could cause the device not to meet its published specifications.

DISCLAIMER

SG Micro Corp reserves the right to make any change in circuit design, or specifications without prior notice.

SGM4T245 4-Bit Dual-Supply Bus Transceiver with Configurable Voltage Translation and 3-State Outputs

RECOMMENDED OPERATING CONDITIONS ^{(1) (2) (3)}

Supply Voltage Range	V_{CCA} 1.2V to 5.0V	V_{CCB} 1.2V to 5.0V	V_{IL} , Low-Level Input Voltage (Control Inputs, referenced to V_{CCA})
	$V_{CCI} = 1.2V$ to 1.4V) $0.85 \times V_{CCI}$ (MIN)	$V_{CCI} = 1.4V$ to 2.3V) $0.75 \times V_{CCI}$ (MIN)	($V_{CCI} = 1.2V$ to 1.4V) $0.1 \times V_{CCA}$ (MAX)
	$V_{CCI} = 2.3V$ to 3.3V) 1.75V (MIN)	$V_{CCI} = 3.3V$ to 5.0V) 2.2V (MIN)	($V_{CCI} = 1.4V$ to 2.3V) $0.15 \times V_{CCA}$ (MAX)
V_{IH} , High-Level Input Voltage (Data Inputs)	($V_{CCI} = 1.2V$ to 1.4V) $0.85 \times V_{CCI}$ (MIN)	($V_{CCI} = 1.4V$ to 2.3V) $0.75 \times V_{CCI}$ (MIN)	($V_{CCI} = 2.3V$ to 3.3V) 0.5V (MAX)
	($V_{CCI} = 2.3V$ to 3.3V) 1.75V (MIN)	($V_{CCI} = 3.3V$ to 5.0V) 2.2V (MIN)	($V_{CCI} = 3.3V$ to 5.0V) 0.65V (MAX)
V_{IL} , Low-Level Input Voltage (Data Inputs)	($V_{CCI} = 1.2V$ to 1.4V) $0.1 \times V_{CCI}$ (MAX)	($V_{CCI} = 1.4V$ to 2.3V) $0.15 \times V_{CCI}$ (MAX)	V_i , Input Voltage Range 0V to 5.0V
	($V_{CCI} = 2.3V$ to 3.3V) 0.5V (MAX)	($V_{CCI} = 3.3V$ to 5.0V) 0.65V (MAX)	V_o , Output Voltage Range
V_{IH} , High-Level Input Voltage (Control Inputs, referenced to V_{CCA})	($V_{CCI} = 1.2V$ to 1.4V) $0.85 \times V_{CCA}$ (MIN)	($V_{CCI} = 1.4V$ to 2.3V) $0.75 \times V_{CCA}$ (MIN)	Active State 0V to V_{CCO}
	($V_{CCI} = 2.3V$ to 3.3V) 1.75V (MIN)	($V_{CCI} = 3.3V$ to 5.0V) 2.2V (MIN)	3-State 0V to 5.0V
			Input Transition Rise or Fall Rate, $\Delta t/\Delta V$ 3ns/V (MAX)
			Operating Temperature Range -40°C to +125°C

NOTES:

1. V_{CCI} is the V_{CC} associated with the input ports.
2. V_{CCO} is the V_{CC} associated with the output ports.
3. All unused data inputs of the device must be held at V_{CCI} or GND to ensure proper device operation.

4-Bit Dual-Supply Bus Transceiver with Configurable Voltage Translation and 3-State Outputs

SGM4T245

PIN CONFIGURATIONS

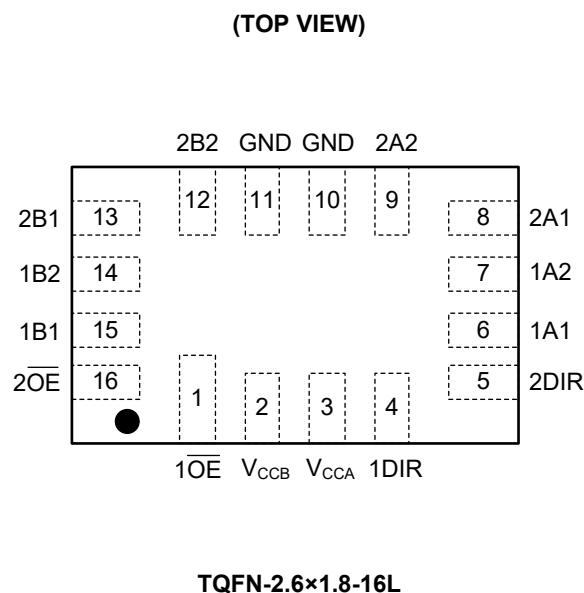
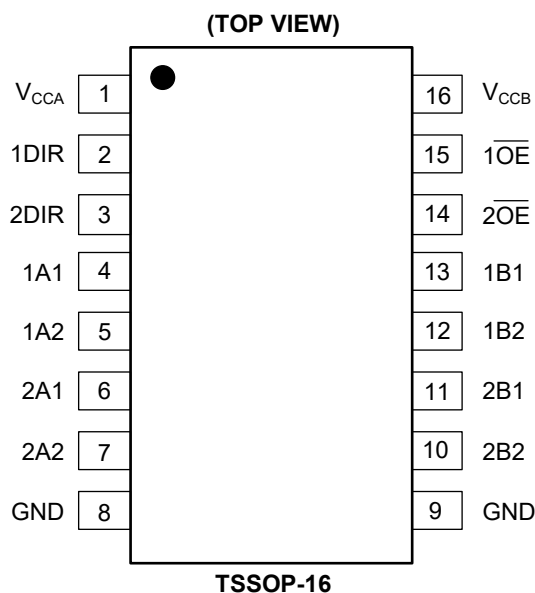

PIN DESCRIPTION

PIN		NAME	I/O	FUNCTION
TSSOP-16	TQFN-2.6×1.8-16L			
1	3	V _{CCA}	–	A Ports Supply Voltage. 1.2V ≤ V _{CCA} ≤ 5.0V.
2	4	1DIR	I	Direction-Control Input for '1' Ports.
3	5	2DIR	I	Direction-Control Input for '2' Ports.
4	6	1A1	I/O	Input/Output 1A1. Referenced to V _{CCA} .
5	7	1A2	I/O	Input/Output 1A2. Referenced to V _{CCA} .
6	8	2A1	I/O	Input/Output 2A1. Referenced to V _{CCA} .
7	9	2A2	I/O	Input/Output 2A2. Referenced to V _{CCA} .
8, 9	10, 11	GND	–	Ground.
10	12	2B2	I/O	Input/Output 2B2. Referenced to V _{CCB} .
11	13	2B1	I/O	Input/Output 2B1. Referenced to V _{CCB} .
12	14	1B2	I/O	Input/Output 1B2. Referenced to V _{CCB} .
13	15	1B1	I/O	Input/Output 1B1. Referenced to V _{CCB} .
14	16	2OE	I	3-State Output-Mode Enables. Pull OE high to place '2' outputs in 3-state mode. Referenced to V _{CCA} .
15	1	1OE	I	3-State Output-Mode Enables. Pull OE high to place '1' outputs in 3-state mode. Referenced to V _{CCA} .
16	2	V _{CCB}	–	B Ports Supply Voltage. 1.2V ≤ V _{CCB} ≤ 5.0V.

4-Bit Dual-Supply Bus Transceiver with Configurable Voltage Translation and 3-State Outputs

SGM4T245

ELECTRICAL CHARACTERISTICS ^{(1) (2)}

(Full = -40°C to +125°C, typical values are at T_A = +25°C, unless otherwise noted.)

PARAMETER	SYMBOL	CONDITIONS		TEMP	MIN	TYP	MAX	UNITS	
High-Level Output Voltage	V _{OH}	V _I = V _{IH}	V _{CCA} = 1.2V to 5.0V, V _{CCB} = 1.2V to 5.0V, I _{OH} = -100μA	+25°C		V _{CCO} - 0.005		V	
			V _{CCA} = 1.2V, V _{CCB} = 1.2V, I _{OH} = -1mA	+25°C		1.17			
			V _{CCA} = 1.4V, V _{CCB} = 1.4V, I _{OH} = -5mA	+25°C		1.27			
			V _{CCA} = 1.65V, V _{CCB} = 1.65V, I _{OH} = -16mA	Full	1.10	1.32			
			V _{CCA} = 2.3V, V _{CCB} = 2.3V, I _{OH} = -20mA	Full	1.90	2			
			V _{CCA} = 5.0V, V _{CCB} = 5.0V, I _{OH} = -20mA	Full	4.70	4.83			
Low-Level Output Voltage	V _{OL}	V _I = V _{IL}	V _{CCA} = 1.2V to 5.0V, V _{CCB} = 1.2V to 5.0V, I _{OL} = 100μA	+25°C		0.005		V	
			V _{CCA} = 1.2V, V _{CCB} = 1.2V, I _{OL} = 1mA	+25°C		0.02			
			V _{CCA} = 1.4V, V _{CCB} = 1.4V, I _{OL} = 5mA	+25°C		0.09			
			V _{CCA} = 1.65V, V _{CCB} = 1.65V, I _{OL} = 16mA	Full		0.25	0.40		
			V _{CCA} = 2.3V, V _{CCB} = 2.3V, I _{OL} = 20mA	Full		0.2	0.36		
			V _{CCA} = 5.0V, V _{CCB} = 5.0V, I _{OL} = 20mA	Full		0.18	0.27		
Input Leakage Current	Control inputs	I _I	V _{CCA} = 1.2V to 5.0V, V _{CCB} = 1.2V to 5.0V, V _I = V _{CCA} or GND	Full		±0.01	11	μA	
Power Off Leakage Current	A or B Ports	I _{OFF}	V _I or V _O = 0V to 5.0V	V _{CCA} = 0V, V _{CCB} = 0V to 5.0V	Full		±0.01	14	μA
				V _{CCA} = 0V to 5.0V, V _{CCB} = 0V	Full		±0.01	14	
3-State Output Leakage	A or B Ports	I _{OZ} ⁽³⁾	V _{CCA} = 5.0V, V _{CCB} = 5.0V, V _O = V _{CCO} or GND, V _I = V _{CCI} or GND, \overline{OE} = V _{IH}	Full		±0.01	11	μA	
Quiescent Supply Current		I _{CCA}	V _{CCA} = 1.2V to 5.0V, V _{CCB} = 1.2V to 5.0V, V _I = V _{CCI} or GND, I _O = 0	Full				15	μA
		I _{CCB}		Full				24	
		I _{CCA} + I _{CCB}		Full				25	
Input Capacitance	Control inputs	C _I	V _{CCA} = 3.3V, V _{CCB} = 3.3V, V _I = 3.3V or GND	+25°C		12.3		pF	
Input/Output Capacitance	A or B Ports	C _{IO}	V _{CCA} = 3.3V, V _{CCB} = 3.3V, V _O = 3.3V or GND	+25°C		9.8		pF	

NOTES:

1. V_{CCO} is the V_{CC} associated with the output ports.
2. V_{CCI} is the V_{CC} associated with the input ports.
3. For I/O ports, the parameter I_{OZ} includes the input leakage current.

4-Bit Dual-Supply Bus Transceiver with SGM4T245 Configurable Voltage Translation and 3-State Outputs

SWITCHING CHARACTERISTICS

(V_{CCA} = 1.2V, unless otherwise noted.)

PARAMETER	FROM (INPUT)	TO (OUTPUT)	V _{CCB} = 1.2V	V _{CCB} = 1.5V	V _{CCB} = 1.8V	V _{CCB} = 2.5V	V _{CCB} = 3.3V	V _{CCB} = 5.0V	UNITS
			TYP	TYP	TYP	TYP	TYP	TYP	
t _{PLH}	A	B	62.1	42.9	36.8	31.9	30.9	31.1	ns
t _{PHL}			143.9	97.7	86.2	77.9	75.3	80.2	
t _{PLH}	B	A	50.8	45.8	43.5	41.0	40.2	39.2	ns
t _{PHL}			132.7	87.8	77.2	71.9	70.2	70.9	
t _{PZH}	\overline{OE}	A	167.5	150.1	146.1	144.1	144.2	146.6	ns
t _{PZL}			123.5	123.5	123.5	123.5	123.5	124.6	
t _{PZH}	\overline{OE}	B	159.3	141.3	134.5	130.5	129.7	131.7	ns
t _{PZL}			132.7	120.3	115.6	110.4	110.9	113.7	
t _{PHZ}	\overline{OE}	A	55.6	55.6	55.6	55.6	55.6	56.0	ns
t _{PLZ}			56.4	56.4	56.4	56.4	56.4	56.9	
t _{PHZ}	\overline{OE}	B	68.2	63.0	63.8	61.9	70.3	72.8	ns
t _{PLZ}			66.0	60.6	59.9	58.7	61.7	64.8	

SWITCHING CHARACTERISTICS (continued)

(V_{CCA} = 1.5V, unless otherwise noted.)

PARAMETER	FROM (INPUT)	TO (OUTPUT)	V _{CCB} = 1.2V	V _{CCB} = 1.5V	V _{CCB} = 1.8V	V _{CCB} = 2.5V	V _{CCB} = 3.3V	V _{CCB} = 5.0V	UNITS
			TYP	TYP	TYP	TYP	TYP	TYP	
t _{PLH}	A	B	46.2	28.0	21.5	16.6	14.6	13.5	ns
t _{PHL}			98.3	54.4	41.9	33.0	29.8	28.0	
t _{PLH}	B	A	31.6	26.3	24.0	21.3	17.6	19.5	ns
t _{PHL}			97.3	52.4	42.6	36.7	34.8	34.4	
t _{PZH}	\overline{OE}	A	83.6	66.2	62.6	60.0	59.5	59.5	ns
t _{PZL}			50.7	50.7	50.7	50.7	50.7	50.7	
t _{PZH}	\overline{OE}	B	82.3	63.5	57.1	52.2	50.4	49.2	ns
t _{PZL}			66.6	54.1	49.3	45.2	43.8	43.4	
t _{PHZ}	\overline{OE}	A	27.8	27.8	27.8	27.8	27.8	27.8	ns
t _{PLZ}			26.3	26.3	26.3	26.3	26.3	26.3	
t _{PHZ}	\overline{OE}	B	38.6	33.1	32.9	31.4	38.3	36.1	ns
t _{PLZ}			35.6	30.3	30.5	27.2	30.0	27.6	

4-Bit Dual-Supply Bus Transceiver with SGM4T245 Configurable Voltage Translation and 3-State Outputs

SWITCHING CHARACTERISTICS (continued)

(V_{CCA} = 1.8V, unless otherwise noted.)

PARAMETER	FROM (INPUT)	TO (OUTPUT)	V _{CCB} = 1.2V	V _{CCB} = 1.5V	V _{CCB} = 1.8V	V _{CCB} = 2.5V	V _{CCB} = 3.3V	V _{CCB} = 5.0V	UNITS
			TYP	TYP	TYP	TYP	TYP	TYP	
t _{PLH}	A	B	42.6	24.4	18.0	12.7	10.8	9.3	ns
t _{PHL}			88.3	45.5	32.1	20.8	20.2	18.2	
t _{PLH}	B	A	25.0	19.4	17.2	14.8	13.8	12.9	ns
t _{PHL}			86.3	40.8	31.5	25.6	23.6	22.9	
t _{PZH}	\overline{OE}	A	61.7	44.0	40.3	37.8	37.4	37.3	ns
t _{PZL}			31.5	31.5	31.5	31.5	31.5	31.5	
t _{PZH}	\overline{OE}	B	64.5	45.6	38.6	33.6	31.6	30.2	ns
t _{PZL}			50.5	38.5	33.3	30.6	27.7	27.1	
t _{PHZ}	\overline{OE}	A	21.6	21.6	21.6	21.6	21.3	21.6	ns
t _{PLZ}			19.8	19.8	19.8	19.8	19.3	19.8	
t _{PHZ}	\overline{OE}	B	32.6	27.1	26.3	23.8	30.1	27.9	ns
t _{PLZ}			27.1	22.6	21.7	18.4	21.5	18.5	

SWITCHING CHARACTERISTICS (continued)

(V_{CCA} = 2.5V, unless otherwise noted.)

PARAMETER	FROM (INPUT)	TO (OUTPUT)	V _{CCB} = 1.2V	V _{CCB} = 1.5V	V _{CCB} = 1.8V	V _{CCB} = 2.5V	V _{CCB} = 3.3V	V _{CCB} = 5.0V	UNITS
			TYP	TYP	TYP	TYP	TYP	TYP	
t _{PLH}	A	B	39.6	21.0	14.8	9.5	7.6	6.0	ns
t _{PHL}			82.1	38.5	25.8	17.0	14.2	11.1	
t _{PLH}	B	A	19.8	14.2	11.8	9.3	8.2	7.4	ns
t _{PHL}			78.9	32.7	22.7	16.9	14.8	14.4	
t _{PZH}	\overline{OE}	A	46.1	29.7	25.6	23.1	22.5	22.2	ns
t _{PZL}			18.9	19.5	19.5	19.5	19.5	19.5	
t _{PZH}	\overline{OE}	B	49.8	33.0	26.5	21.0	19.0	17.9	ns
t _{PZL}			39.8	26.7	22.7	18.5	17.0	15.9	
t _{PHZ}	\overline{OE}	A	13.4	13.4	13.4	13.4	13.4	13.4	ns
t _{PLZ}			11.0	11.0	11.0	11.0	11.0	11.0	
t _{PHZ}	\overline{OE}	B	24.6	18.7	19.5	17.2	23.6	21.0	ns
t _{PLZ}			21.4	16.1	16.3	12.8	15.5	12.5	

4-Bit Dual-Supply Bus Transceiver with SGM4T245 Configurable Voltage Translation and 3-State Outputs

SWITCHING CHARACTERISTICS (continued)

(V_{CCA} = 3.3V, unless otherwise noted.)

PARAMETER	FROM (INPUT)	TO (OUTPUT)	V _{CCB} = 1.2V	V _{CCB} = 1.5V	V _{CCB} = 1.8V	V _{CCB} = 2.5V	V _{CCB} = 3.3V	V _{CCB} = 5.0V	UNITS
			TYP	TYP	TYP	TYP	TYP	TYP	
t _{PLH}	A	B	38.2	19.8	14.9	8.3	6.4	5.0	ns
t _{PHL}			80.0	36.6	22.5	15.1	12.0	10.6	
t _{PLH}	B	A	18.6	12.0	9.7	7.2	6.4	5.2	ns
t _{PHL}			76.6	29.9	19.7	13.7	12.7	12.4	
t _{PZH}	\overline{OE}	A	39.8	24.1	20.2	17.8	17.2	16.8	ns
t _{PZL}			14.1	14.1	14.1	14.4	14.1	14.1	
t _{PZH}	\overline{OE}	B	46.1	28.0	21.8	16.5	14.8	13.2	ns
t _{PZL}			40.3	25.2	20.0	15.8	14.0	12.7	
t _{PHZ}	\overline{OE}	A	17.4	17.4	17.4	17.4	17.4	17.4	ns
t _{PLZ}			10.9	10.9	10.9	10.9	10.9	10.9	
t _{PHZ}	\overline{OE}	B	22.1	16.5	16.8	14.3	21.6	19.1	ns
t _{PLZ}			18.6	13.7	13.2	10.2	12.6	9.9	

SWITCHING CHARACTERISTICS (continued)

(V_{CCA} = 5.0V, unless otherwise noted.)

PARAMETER	FROM (INPUT)	TO (OUTPUT)	V _{CCB} = 1.2V	V _{CCB} = 1.5V	V _{CCB} = 1.8V	V _{CCB} = 2.5V	V _{CCB} = 3.3V	V _{CCB} = 5.0V	UNITS
			TYP	TYP	TYP	TYP	TYP	TYP	
t _{PLH}	A	B	37.3	18.9	12.7	7.4	5.4	3.7	ns
t _{PHL}			76.3	36.5	23.6	14.7	10.4	9.6	
t _{PLH}	B	A	21.3	11.2	8.2	5.8	4.9	3.7	ns
t _{PHL}			83.2	30.5	18.2	11.9	10.3	9.4	
t _{PZH}	\overline{OE}	A	37.5	20.6	17.6	15.1	13.9	13.6	ns
t _{PZL}			11.4	11.4	11.4	11.4	11.4	11.4	
t _{PZH}	\overline{OE}	B	47.7	27.6	20.9	15.3	13.3	11.7	ns
t _{PZL}			34.2	22.2	17.3	13.1	11.9	11.0	
t _{PHZ}	\overline{OE}	A	14.3	14.3	14.3	14.3	14.3	14.3	ns
t _{PLZ}			6.3	6.3	6.3	6.3	6.3	6.3	
t _{PHZ}	\overline{OE}	B	20.0	14.5	15.0	12.9	18.1	16.0	ns
t _{PLZ}			17.3	13.4	11.9	8.3	10.5	7.6	

OPERATING CHARACTERISTICS

(T_A = +25°C, unless otherwise noted.)

PARAMETER	TEST CONDITIONS	V _{CCA} /V _{CCB}					UNITS
		1.5V	1.8V	2.5V	3.3V	5.0V	
		TYP	TYP	TYP	TYP	TYP	
C _{PD} ⁽¹⁾	A to B B to A	C _L = 0, f = 10MHz, t _r = t _f = 1ns					pF
		0.5	0.5	0.9	0.7	1.4	
		0.5	0.5	0.5	0.6	0.7	

NOTE: 1. Power dissipation capacitance per transceiver.

SGM4T245 4-Bit Dual-Supply Bus Transceiver with Configurable Voltage Translation and 3-State Outputs

TYPICAL APPLICATION CIRCUIT

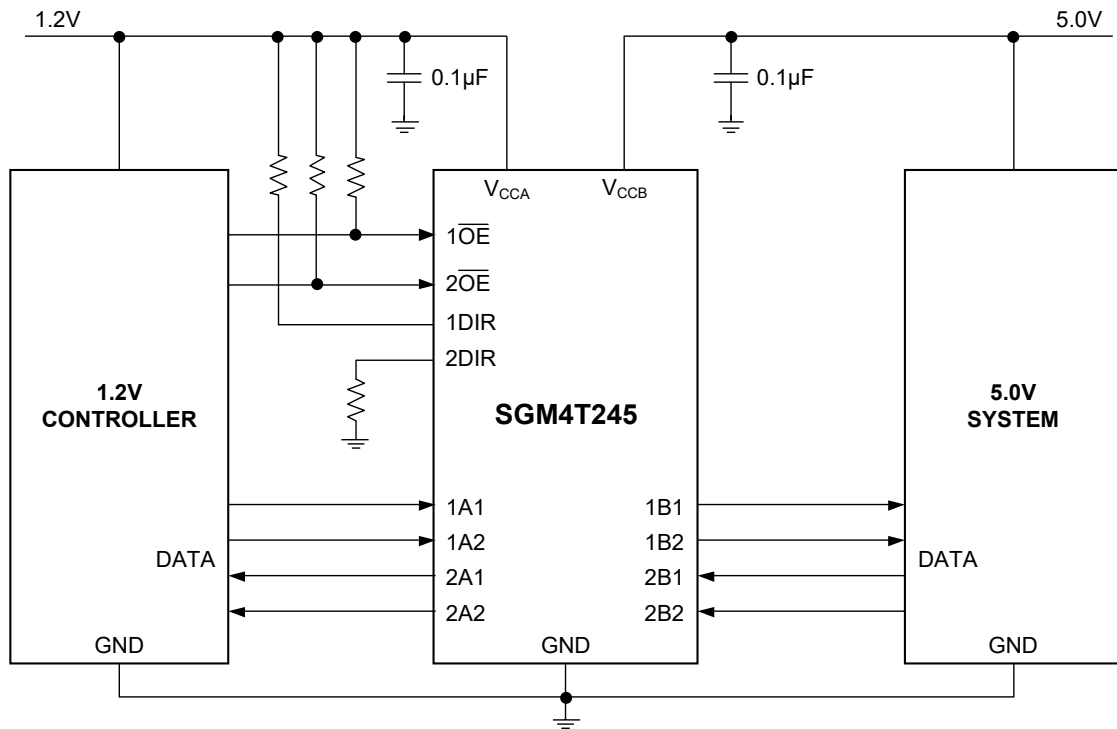

Figure 1. Typical Application Circuit

4-Bit Dual-Supply Bus Transceiver with Configurable Voltage Translation and 3-State Outputs

SGM4T245

PARAMETER MEASUREMENT INFORMATION

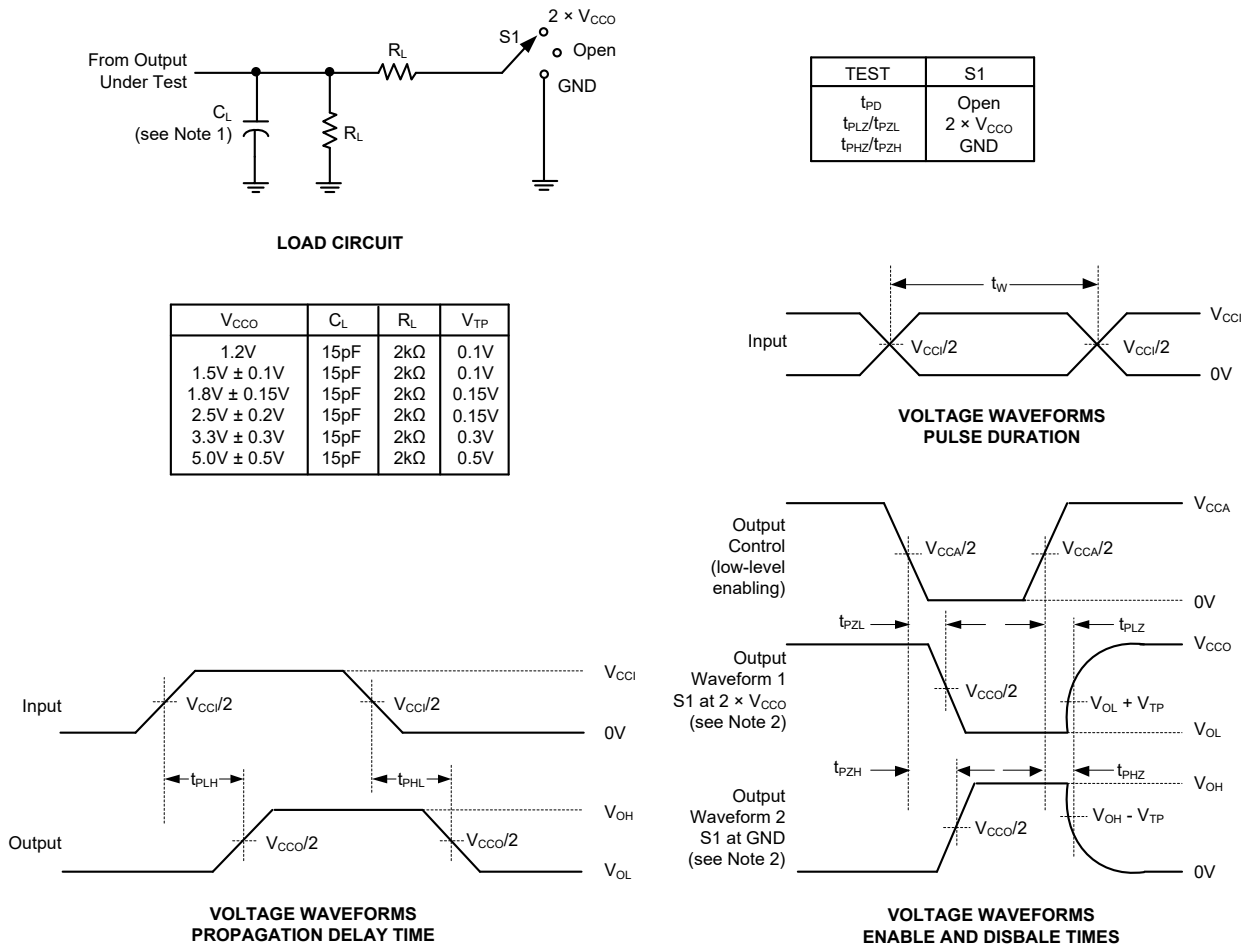

Figure 2. Load Circuit and Voltage Waveforms

NOTES:

1. C_L includes probe and jig capacitance.
2. Waveform 1 is for an output with internal conditions such that the output is low, except when disabled by the output control. Waveform 2 is for an output with internal conditions such that the output is high, except when disabled by the output control.
3. All input pulses are supplied by generators having the following characteristics: $PRR \leq 10\text{MHz}$, $Z_O = 50\Omega$, $dv/dt \geq 1\text{V/ns}$.
4. The outputs are measured one at a time, with one transition per measurement.
5. t_{PLZ} and t_{PHZ} are the same as t_{DIS} .
6. t_{PZL} and t_{PZH} are the same as t_{EN} .
7. t_{PLH} and t_{PHL} are the same as t_{PD} .
8. V_{CCI} is the V_{CC} associated with the input ports.
9. V_{CCO} is the V_{CC} associated with the output ports.

SGM4T245 4-Bit Dual-Supply Bus Transceiver with Configurable Voltage Translation and 3-State Outputs

DETAILED DESCRIPTION

Overview

The SGM4T245 is a 4-bit, dual supply non-inverting bidirectional voltage-level translator. Pins A and control pins (DIR and \overline{OE}) are supported by V_{CCA} and pins B are supported by V_{CCB} . The A port is able to accept I/O voltages ranging from 1.2V to 5.0V while the B port can accept I/O voltages from 1.2V to 5.0V. A high on DIR allows data transmission from A to B and a low on DIR allows data transmission from B to A when \overline{OE} is set to low. When \overline{OE} is set to high, both A and B are in the high-impedance state.

Fully Configurable Dual-Rail Design Allows Each Port to Operate Over the Full 1.2V to 5.0V Power-Supply Range

Both V_{CCA} and V_{CCB} can be supplied at any voltage between 1.2V and 5.0V, making the device suitable for translating between any of the low voltage nodes (1.2V, 1.5V, 1.8V, 2.5V, 3.3V and 5.0V).

I_{OFF} Supports Partial-Power-Down Mode Operation

I_{OFF} will prevent backflow current by disabling I/O output circuits when device is in partial power-down mode.

Device Functional Modes

The SGM4T245 is a voltage-level translator that can operate from 1.2V to 5.0V (V_{CCA}) and 1.2V to 5.0V (V_{CCB}). The signal translation between 1.2V and 5.0V requires direction control and output enable control. When \overline{OE} is low and DIR is high, data transmission is from A to B. When \overline{OE} is low and DIR is low, data transmission is from B to A. When \overline{OE} is high, both output ports will be high-impedance.

Table 1. Function Table (Each 4-Bit Section)

INPUTS		OPERATION
\overline{OE}	DIR	
L	L	B data to A bus.
L	H	A data to B bus.
H	X	All outputs Hi-Z.

SGM4T245 4-Bit Dual-Supply Bus Transceiver with Configurable Voltage Translation and 3-State Outputs

APPLICATION INFORMATION

The SGM4T245 can be used in level-translation applications for interfacing devices or systems operating at different interface voltages with one another. The SGM4T245 is ideal for data transmission which direction is different with each channel.

Design Requirements

For this design example, use the parameters listed in Table 2.

Table 2. Design Parameters

DESIGN PARAMETERS	EXAMPLE VALUE
Input Voltage Range	1.2V to 5.0V
Output Voltage Range	1.2V to 5.0V

Detailed Design Procedure

To begin the design process, determine the following:

1. Input voltage range

Use the supply voltage of the device that is driving the SGM4T245 to determine the input voltage range. For a valid logic high the value must exceed the V_{IH} of the input port. For a valid logic low the value must be less than the V_{IL} of the input port.

2. Output voltage range

Use the supply voltage of the device that the SGM4T245 is driving to determine the output voltage range.

Power Supply Recommendations

The SGM4T245 uses two separate configurable power-supply rails, V_{CCA} and V_{CCB} . V_{CCA} accepts any supply voltage from 1.2V to 5.0V and V_{CCB} accepts any supply voltage from 1.2V to 5.0V. The A port and B port are designed to track V_{CCA} and V_{CCB} , respectively, allowing for low-voltage bidirectional translation between any of the 1.2V, 1.5V, 1.8V, 2.5V 3.3V and 5.0V voltage nodes.

The output-enable \overline{OE} input circuit is designed so that it is supplied by V_{CCA} and when the \overline{OE} input is high, all outputs are placed in the high-impedance state. To ensure the high-impedance state of the outputs during power up or power down, the \overline{OE} input pin must be tied to V_{CCA} through a pull-up resistor and must not be enabled until V_{CCA} and V_{CCB} are fully ramped and stable. The minimum value of the pull-up resistor to V_{CCA} is determined by the current-sinking capability of the driver.

Layout Guidelines

To ensure reliability of the device, following common printed-circuit board layout guidelines is recommended.

1. Bypass capacitors should be used on power supplies.
2. Short trace lengths should be used to avoid excessive loading.
3. Placing pads on the signal paths for loading capacitors or pull-up resistors to help adjust rise and fall times of signals depending on the system requirements.

REVISION HISTORY

NOTE: Page numbers for previous revisions may differ from page numbers in the current version.

Changes from Original (JULY 2018) to REV.A

Changed from product preview to production data.....All

PACKAGE OUTLINE DIMENSIONS

TSSOP-16

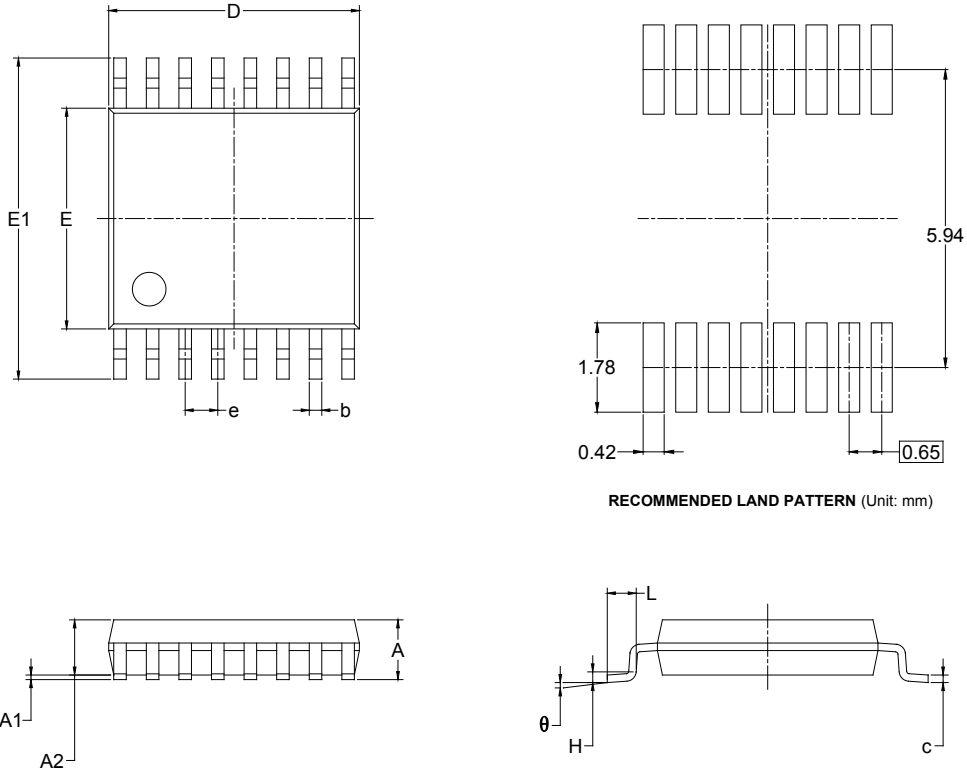

Symbol	Dimensions In Millimeters		Dimensions In Inches	
	MIN	MAX	MIN	MAX
A		1.200		0.047
A1	0.050	0.150	0.002	0.006
A2	0.800	1.050	0.031	0.041
b	0.190	0.300	0.007	0.012
c	0.090	0.200	0.004	0.008
D	4.860	5.100	0.191	0.201
E	4.300	4.500	0.169	0.177
E1	6.200	6.600	0.244	0.260
e	0.650 BSC		0.026 BSC	
L	0.500	0.700	0.02	0.028
H	0.25 TYP		0.01 TYP	
θ	1°	7°	1°	7°

PACKAGE OUTLINE DIMENSIONS

TQFN-2.6×1.8-16L

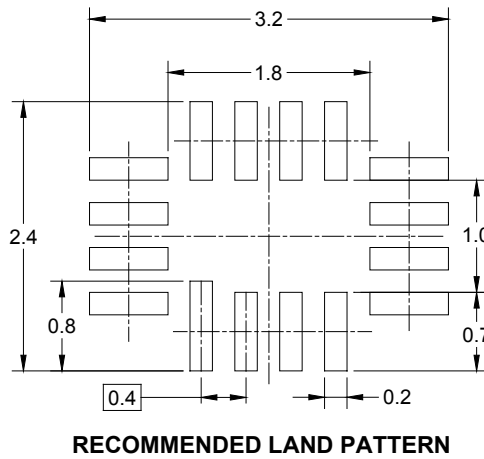
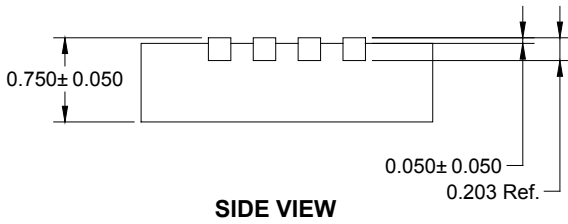
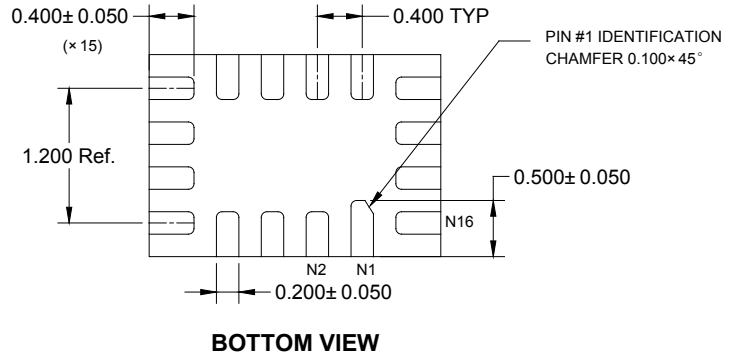
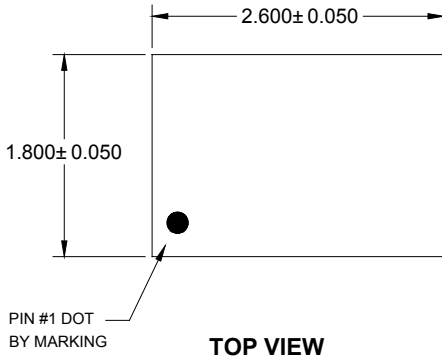

NOTE: All linear dimensions are in millimeters.

PACKAGE INFORMATION

TAPE AND REEL INFORMATION

REEL DIMENSIONS

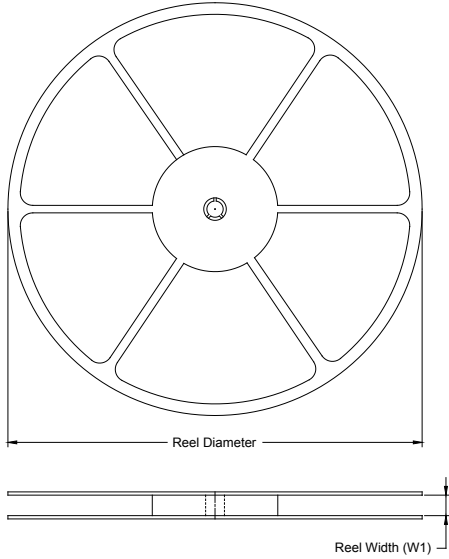

TAPE DIMENSIONS

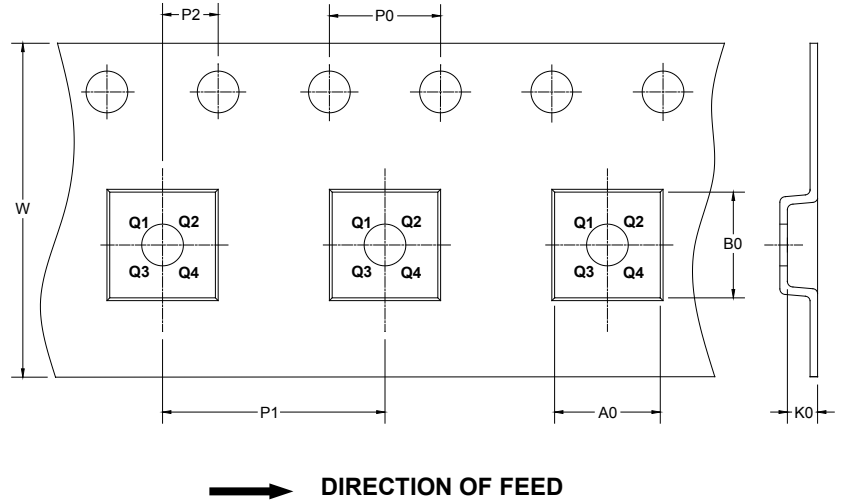

NOTE: The picture is only for reference. Please make the object as the standard.

KEY PARAMETER LIST OF TAPE AND REEL

Package Type	Reel Diameter	Reel Width W1 (mm)	A0 (mm)	B0 (mm)	K0 (mm)	P0 (mm)	P1 (mm)	P2 (mm)	W (mm)	Pin1 Quadrant
TQFN-2.6×1.8-16L	7"	9.0	2.01	2.81	0.93	4.0	4.0	2.0	8.0	Q1
TSSOP-16	13"	12.4	6.90	5.60	1.20	4.0	8.0	2.0	12.0	Q1

DD0001

PACKAGE INFORMATION

CARTON BOX DIMENSIONS

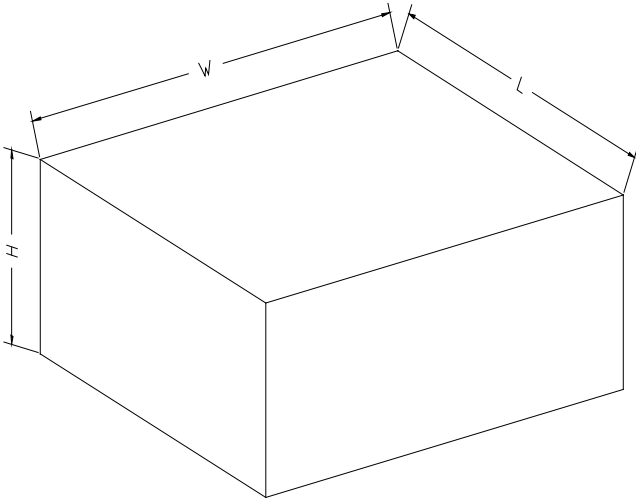

NOTE: The picture is only for reference. Please make the object as the standard.

KEY PARAMETER LIST OF CARTON BOX

Reel Type	Length (mm)	Width (mm)	Height (mm)	Pizza/Carton
7" (Option)	368	227	224	8
7"	442	410	224	18
13"	386	280	370	5

DD0002

单击下面可查看定价，库存，交付和生命周期等信息

[>>SGMICRO\(圣邦微电子\)](#)