



SGM2553/SGM2553D

Precision Adjustable Current Limited Power Distribution Switches

GENERAL DESCRIPTION

The SGM2553 and SGM2553D are single channel power distribution switches. The switch operates from a wide range of 2.5V to 5.5V supply voltage, and is controlled by the EN pin.

A 90mΩ low R_{ON} N-MOSFET is integrated. It is capable of supplying up to 1.5A continuous current. The small size and quiescent current make the device very suitable for space limited, battery-powered applications.

A number of protection features are provided in the device including soft-start, over-current protection, adjustable current limit and thermal shutdown. This device provides a programmable current limit threshold between 100mA and 1.7A through the R_{ILIM} . The internal reverse-voltage function will protect devices on the input side of the switch. Fault conditions are indicated by the nFAULT pin. The SGM2553D has quick output discharge function in disable status.

SGM2553 and SGM2553D are available in the Green TDFN-2×2-6L and SOT-23-6 packages. They are rated over the -40°C to +85°C temperature range.

FEATURES

- **Input Voltage Range: 2.5V to 5.5V**
- **On-Resistance: 90mΩ (TYP)**
- **Continuous Current: 1.5A (MAX)**
- **Programmable Current Limit: 100mA to 1.7A**
- **Fast Over-Current Response: 2μs**
- **Protection Features**
 - ◆ **No Reverse Leakage Current of High-side MOSFET**
 - ◆ **Reverse Voltage Protection**
 - ◆ **Soft-Start**
- **Quick Output Discharge: SGM2553D**
- **Evaluated to IEC 60950-1, Ed 2, Am1, Annex CC, Test Program 1 with CB Report**
- **Available in the Green TDFN-2×2-6L and SOT-23-6 Packages**

APPLICATIONS

Hot-Plug Power Supply
Motherboard USB Power Switch
Accessories
Portable Medical Equipment

PACKAGE/ORDERING INFORMATION

MODEL	PACKAGE DESCRIPTION	SPECIFIED TEMPERATURE RANGE	ORDERING NUMBER	PACKAGE MARKING	PACKING OPTION
SGM2553	SOT-23-6	-40°C to +85°C	SGM2553YN6G/TR	SJ7XX	Tape and Reel, 3000
	TDFN-2x2-6L	-40°C to +85°C	SGM2553YTDI6G/TR	2553 XXXX	Tape and Reel, 3000
SGM2553D	SOT-23-6	-40°C to +85°C	SGM2553DYN6G/TR	SJ8XX	Tape and Reel, 3000
	TDFN-2x2-6L	-40°C to +85°C	SGM2553DYTDI6G/TR	SJ4 XXXX	Tape and Reel, 3000

MARKING INFORMATION

NOTE: XX = Date Code. XXXX = Date Code.

SOT-23-6

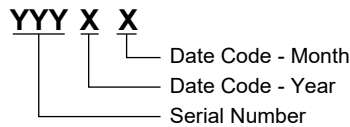

TDFN-2x2-6L

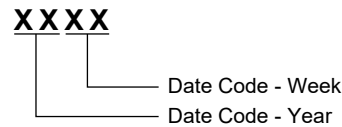

Green (RoHS & HSF): SG Micro Corp defines "Green" to mean Pb-Free (RoHS compatible) and free of halogen substances. If you have additional comments or questions, please contact your SGMICRO representative directly.

ABSOLUTE MAXIMUM RATINGS

- VIN, VOUT, EN, ILIM and FAULT to GND..... -0.3V to 6V
- Continuous Output Current..... Internally Limited
- Continuous FAULT Sink Current..... 25mA
- ILIM Source Current 1mA
- Package Thermal Resistance
- TDFN-2x2-6L, θ_{JA} 160°C/W
- SOT-23-6, θ_{JA} 260°C/W
- Junction Temperature +150°C
- Storage Temperature Range..... -65°C to +150°C
- Lead Temperature (Soldering, 10s) +260°C
- ESD Susceptibility
- HBM..... 2000V
- MM..... 200V

RECOMMENDED OPERATING CONDITIONS

- Input Voltage Range 2.5V to 5.5V
- Enable Voltage Range..... 0V to 5.5V
- Continuous Output Current Range 0A to 1.5A
- Current Limit Threshold Resistor Range..... 20kΩ to 387kΩ
- Continuous FAULT Sink Current Range 0mA to 10mA
- Minimum Input Decoupling Capacitance 0.1μF
- Operating Temperature Range -40°C to +85°C

OVERSTRESS CAUTION

Stresses beyond those listed in Absolute Maximum Ratings may cause permanent damage to the device. Exposure to absolute maximum rating conditions for extended periods may affect reliability. Functional operation of the device at any conditions beyond those indicated in the Recommended Operating Conditions section is not implied.

ESD SENSITIVITY CAUTION

This integrated circuit can be damaged if ESD protections are not considered carefully. SGMICRO recommends that all integrated circuits be handled with appropriate precautions. Failure to observe proper handling and installation procedures can cause damage. ESD damage can range from subtle performance degradation to complete device failure. Precision integrated circuits may be more susceptible to damage because even small parametric changes could cause the device not to meet the published specifications.

DISCLAIMER

SG Micro Corp reserves the right to make any change in circuit design, or specifications without prior notice.

PIN CONFIGURATIONS

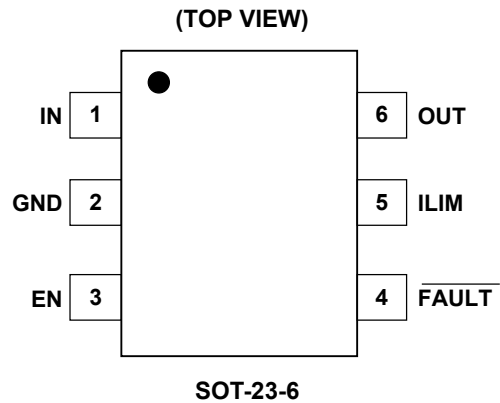
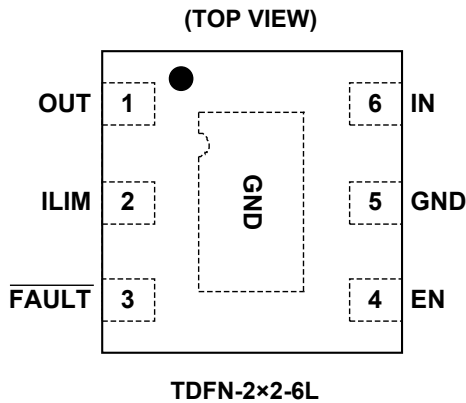

PIN DESCRIPTION

PIN		NAME	FUNCTION
TDFN-2x2-6L	SOT-23-6		
1	6	OUT	Switch Output.
2	5	ILIM	Programmable Current Limit Pin. External resistor ($20\text{k}\Omega \leq R_{\text{ILIM}} \leq 387\text{k}\Omega$) used to set current limit threshold. $I_{\text{LIM}} = \frac{39}{R_{\text{ILIM}} + 3} \text{ (A)}$ where R_{ILIM} is in $\text{k}\Omega$.
3	4	$\overline{\text{FAULT}}$	Alert Output Pin. Fault conditions (over-current, over-temperature, or reverse-voltage conditions) are indicated by the nFAULT pin.
4	3	EN	Enable Input. Logic high to enable the device.
5	2	GND	Ground.
6	1	IN	Switch Input. A $0.1\mu\text{F}$ or larger ceramic capacitor needs to be added between IN pin and GND.
Exposed Pad	—	GND	GND.

ELECTRICAL CHARACTERISTICS

($V_{IN} = 5V$, $R_{FAULT} = 10k\Omega$, $T_A = +25^\circ C$, unless otherwise noted.)

PARAMETER	SYMBOL	CONDITIONS	MIN	TYP	MAX	UNITS
Power Switch						
High-side MOSFET On Resistance	$R_{DS(ON)}$			90	130	m Ω
Output Rise Time	t_R	$V_{IN} = 5.5V$	$C_L = 1\mu F, R_L = 100\Omega,$ Figure 2	1.8	3.5	ms
		$V_{IN} = 2.5V$		1.1	2.5	
Output Fall Time	t_F	$V_{IN} = 5.5V$		0.3	0.4	
		$V_{IN} = 2.5V$		0.3	0.4	
Enable Input						
Logic High of Enable Pin	V_{IH}		1.4			V
Logic Low of Enable Pin	V_{IL}				0.3	V
Input Current	I_{EN}	$V_{EN} = 5.5V$		0.01	1	μA
Turn-On Time	t_{ON}	$C_L = 1\mu F, R_L = 100\Omega,$ Figure 2		3	5	ms
Turn-Off Time	t_{OFF}			1.6	2.5	ms
Current Limit						
Current Limit Threshold (Maximum DC output current I_{OUT} delivered to load), OUT connected to GND through 4 Ω .	I_{LIM}	$V_{IN} = 3V, R_{LIM} = 68k\Omega$	460	545	610	mA
Response Time to Short Circuit	t_{IOS}	Figure 3		2		μs
Reverse-Voltage Protection						
Reverse-Voltage Comparator Trip Point ($V_{OUT} - V_{IN}$)			115	160	205	mV
Time from Reverse-Voltage Condition to MOSFET Turn-Off			3.5	5.5	7.5	ms
Supply Current						
Supply Current, Low-Level Output	$I_{IN(OFF)}$	$V_{IN} = 5.5V, \text{No load on OUT}, V_{EN} = 0V$		0.1	2.5	μA
Supply Current, High-Level Output	$I_{IN(ON)}$	$R_{LIM} = 36k\Omega$	$V_{IN} = 5.5V,$ No load on OUT	71	105	μA
		$R_{LIM} = 68k\Omega$		62	95	
Reverse Leakage Current	I_{REV}	$V_{OUT} = 5.5V, V_{IN} = 0V$		0.01	1	μA
Under-Voltage Lockout						
Under-Voltage Lockout Threshold	V_{UVLO}	V_{IN} Rising		2.36	2.47	V
Under-Voltage Lockout Threshold Hysteresis				140		mV
Quick Discharge Resistor (SGM2553d Only)						
Discharge Resistor	$R_{Discharge}$			45		Ω
FAULT Flag						
\overline{FAULT} Output Low Voltage		$I_{FAULT} = 1mA$		95	150	mV
Off-State Leakage		$V_{FAULT} = 5.5V$		0.02	1	μA
\overline{FAULT} Deglitch		\overline{FAULT} assertion or de-assertion due to over-current condition.	6.5	10	14	ms
		\overline{FAULT} assertion or de-assertion due to reverse-voltage condition.	3.5	5.5	7.5	
Thermal Shutdown						
Thermal Shutdown Threshold				140		$^\circ C$
Thermal Shutdown Threshold in Current Limit				115		$^\circ C$
Thermal Shutdown Hysteresis				10		$^\circ C$

TYPICAL PERFORMANCE CHARACTERISTICS

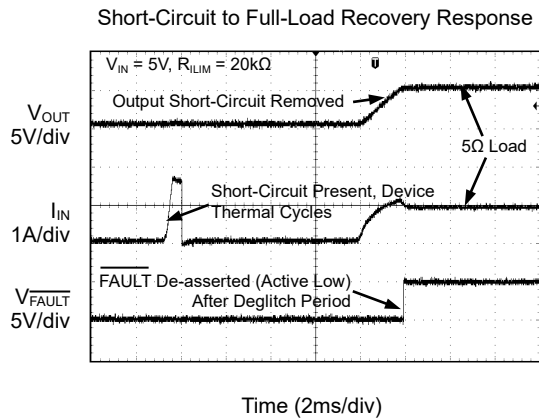
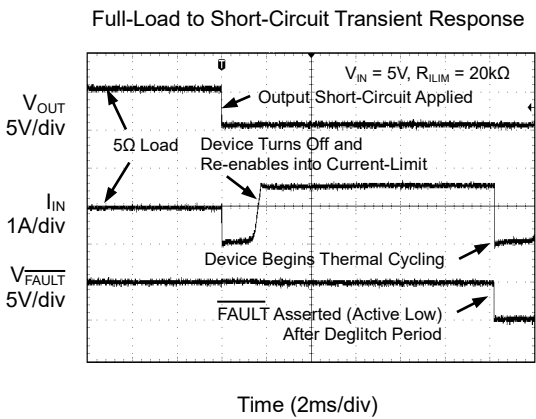
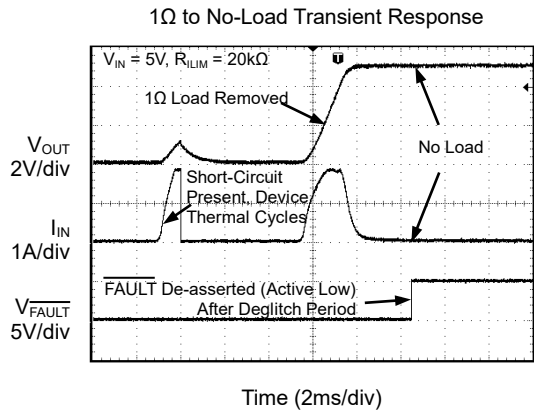
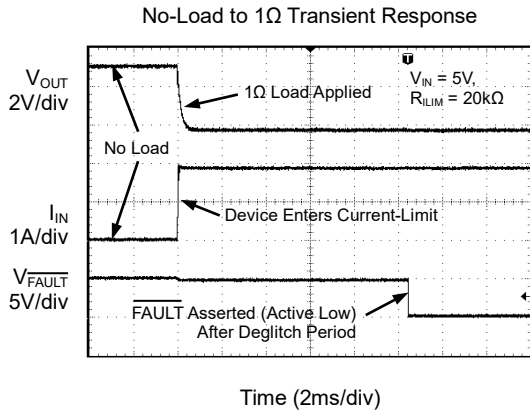
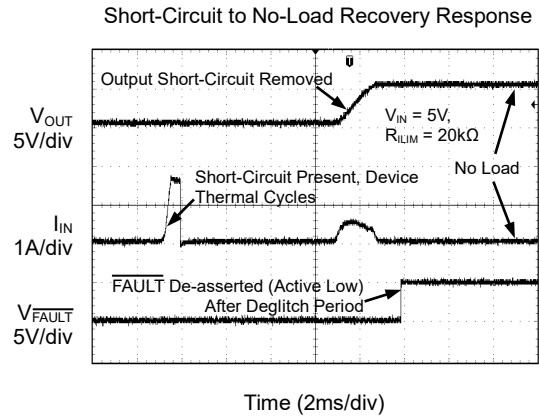
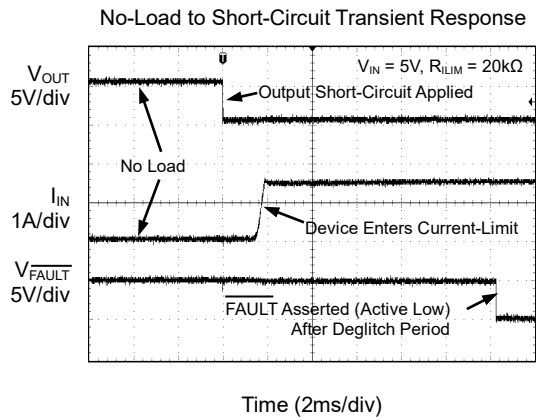

TYPICAL PERFORMANCE CHARACTERISTICS (continued)

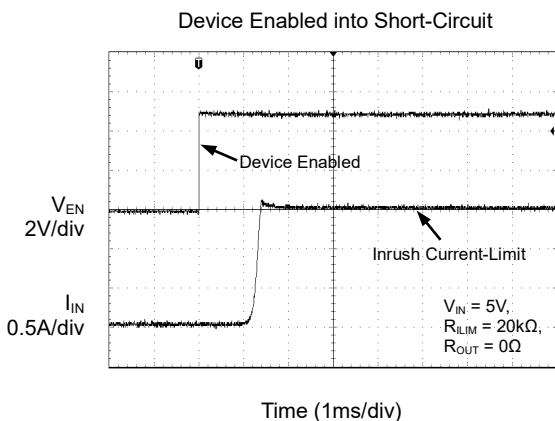
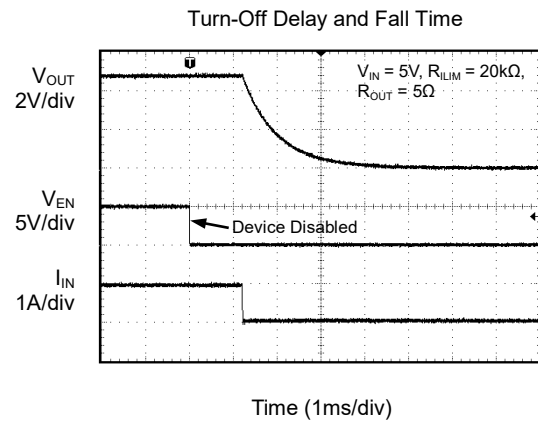
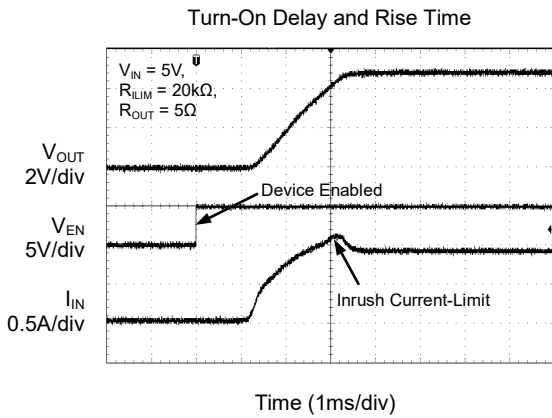
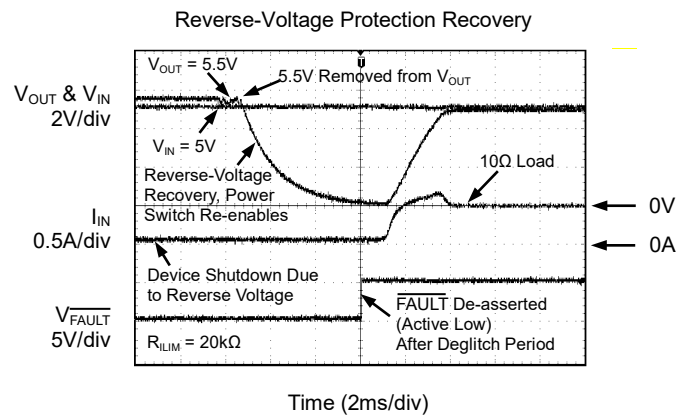
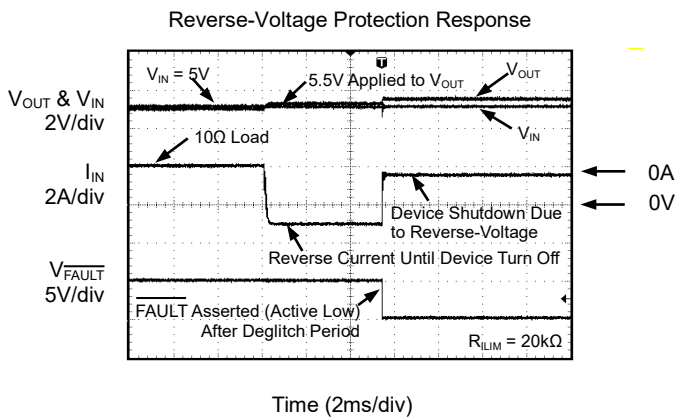

TYPICAL PERFORMANCE CHARACTERISTICS (continued)

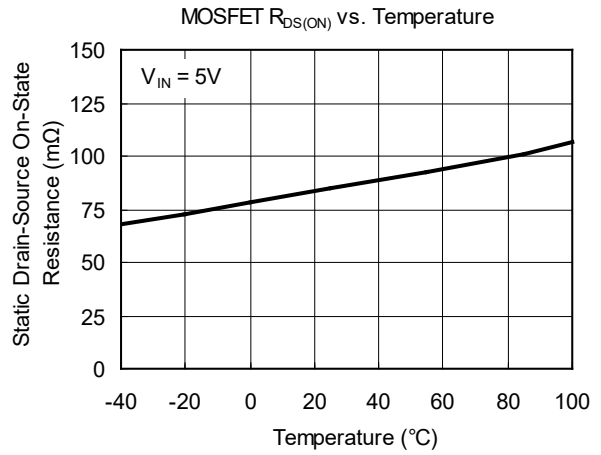
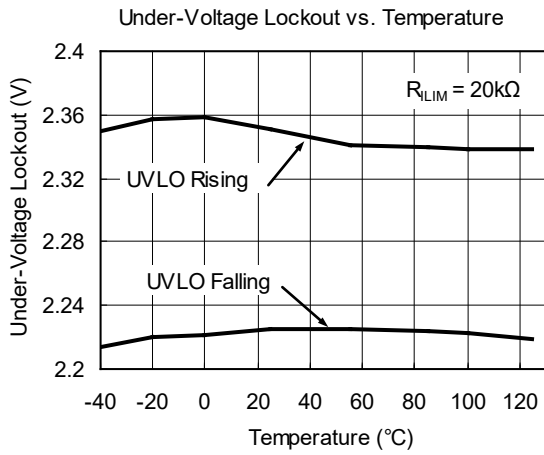
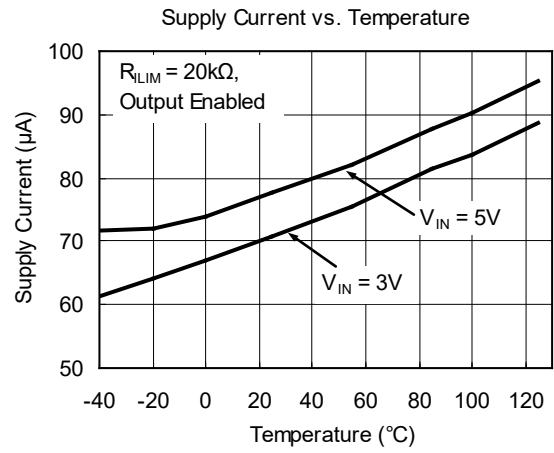
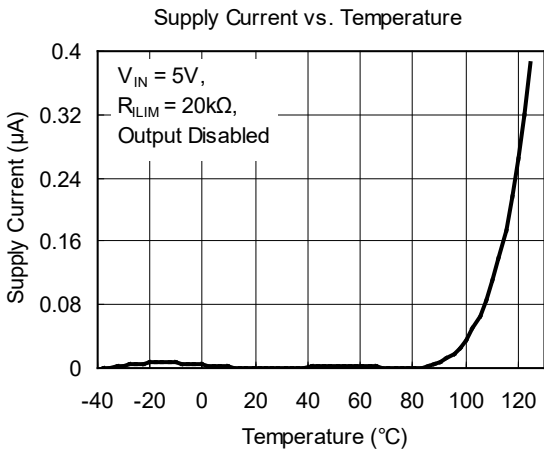

REVISION HISTORY

NOTE: Page numbers for previous revisions may differ from page numbers in the current version.

JUNE 2018 – REV.A.2 to REV.A.3

Update Recommended Operating Conditions	2
---	---

DECEMBER 2017 – REV.A.1 to REV.A.2

Update Feature section	1
------------------------------	---

APRIL 2015 – REV.A to REV.A.1

Change the C _{OUT} of Figure 1&4.....	1, 5
--	------

Changes from Original (FEBRUARY 2015) to REV.A

Changed from product preview to production data.....	All
--	-----

PACKAGE OUTLINE DIMENSIONS

TDFN-2x2-6L

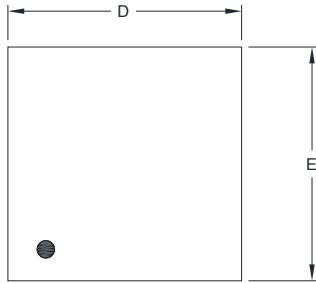

TOP VIEW

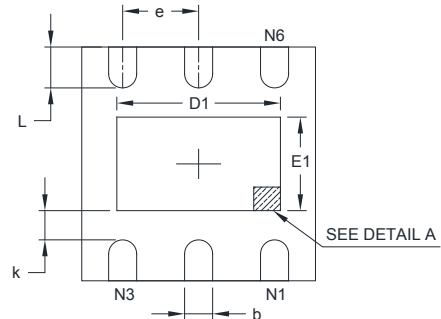

BOTTOM VIEW

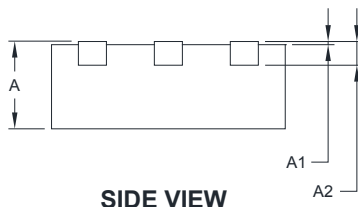

SIDE VIEW

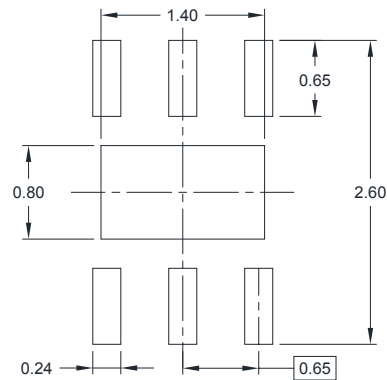

RECOMMENDED LAND PATTERN (Unit: mm)

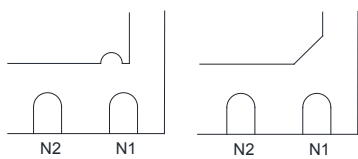

DETAIL A

Pin #1 ID and Tie Bar Mark Options

NOTE: The configuration of the Pin #1 identifier is optional, but must be located within the zone indicated.

Symbol	Dimensions In Millimeters		Dimensions In Inches	
	MIN	MAX	MIN	MAX
A	0.700	0.800	0.028	0.031
A1	0.000	0.050	0.000	0.002
A2	0.203 REF		0.008 REF	
D	1.900	2.100	0.075	0.083
D1	1.100	1.450	0.043	0.057
E	1.900	2.100	0.075	0.083
E1	0.600	0.850	0.024	0.034
k	0.200 MIN		0.008 MIN	
b	0.180	0.300	0.007	0.012
e	0.650 TYP		0.026 TYP	
L	0.250	0.450	0.010	0.018

PACKAGE OUTLINE DIMENSIONS

SOT-23-6

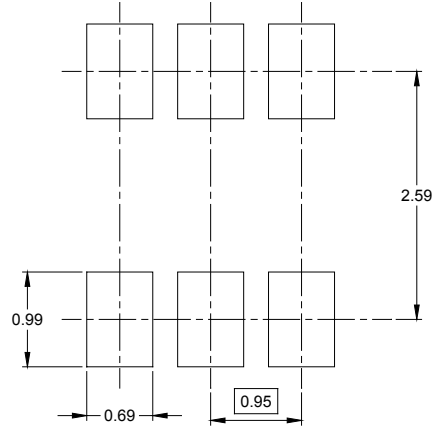
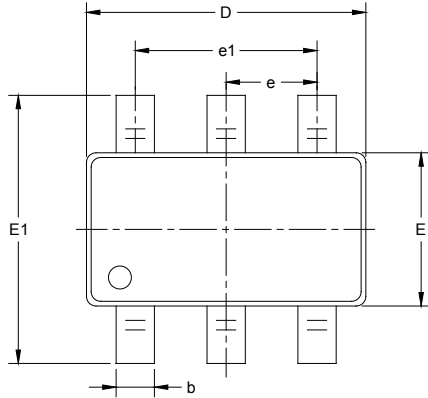

RECOMMENDED LAND PATTERN (Unit: mm)

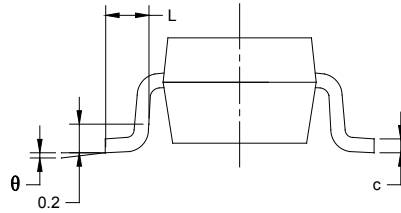
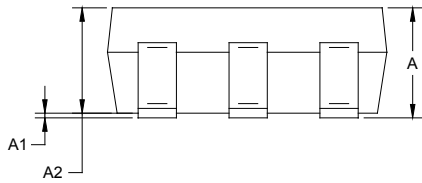

Symbol	Dimensions In Millimeters		Dimensions In Inches	
	MIN	MAX	MIN	MAX
A	1.050	1.250	0.041	0.049
A1	0.000	0.100	0.000	0.004
A2	1.050	1.150	0.041	0.045
b	0.300	0.500	0.012	0.020
c	0.100	0.200	0.004	0.008
D	2.820	3.020	0.111	0.119
E	1.500	1.700	0.059	0.067
E1	2.650	2.950	0.104	0.116
e	0.950 BSC		0.037 BSC	
e1	1.900 BSC		0.075 BSC	
L	0.300	0.600	0.012	0.024
θ	0°	8°	0°	8°

TAPE AND REEL INFORMATION

REEL DIMENSIONS



TAPE DIMENSIONS



NOTE: The picture is only for reference. Please make the object as the standard.

KEY PARAMETER LIST OF TAPE AND REEL

Package Type	Reel Diameter	Reel Width W1 (mm)	A0 (mm)	B0 (mm)	K0 (mm)	P0 (mm)	P1 (mm)	P2 (mm)	W (mm)	Pin1 Quadrant
SOT-23-6	7"	9.5	3.17	3.23	1.37	4.0	4.0	2.0	8.0	Q3
TDFN-2x2-6L	7"	9.5	2.30	2.30	1.10	4.0	4.0	2.0	8.0	Q1

000001

PACKAGE INFORMATION

CARTON BOX DIMENSIONS

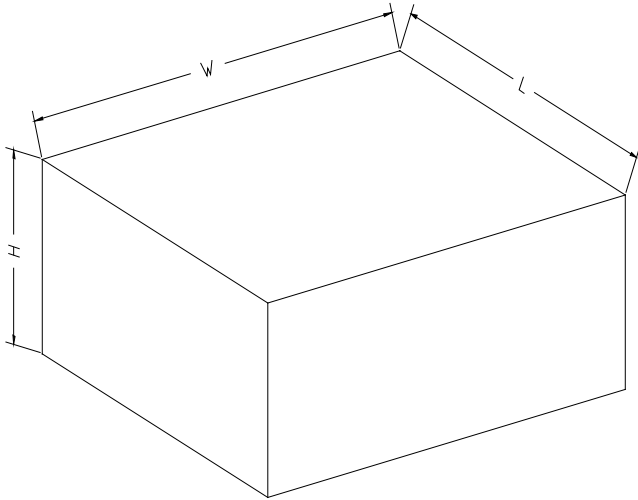

NOTE: The picture is only for reference. Please make the object as the standard.

KEY PARAMETER LIST OF CARTON BOX

Reel Type	Length (mm)	Width (mm)	Height (mm)	Pizza/Carton
7" (Option)	368	227	224	8
7"	442	410	224	18

DD0002

单击下面可查看定价，库存，交付和生命周期等信息

[>>SGMICRO\(圣邦微电子\)](#)