



SGM8250-1/SGM8250-2 High Voltage, Micro-Power, Zero-Drift, CMOS Operational Amplifiers

GENERAL DESCRIPTION

The single SGM8250-1 and dual SGM8250-2 are high voltage, high precision CMOS operational amplifiers, which can operate from 3V to 24V single supply or from $\pm 1.5V$ to $\pm 12V$ dual power supplies, while consuming only 50 μA quiescent current per amplifier. The SGM8250-1/2 support rail-to-rail input and output operation. The input common mode voltage range is 100mV beyond the rails, and the output swings within 65mV of the rails.

The SGM8250-1/2 feature high impedance inputs, a 50 μV maximum input offset voltage and zero-drift over time and temperature. These specifications make the operational amplifiers appropriate for high precision applications.

The SGM8250-1 is available in Green SOT-23-5, SC70-5 and SOIC-8 packages. The SGM8250-2 is available in Green TDFN-3 \times 3-8L and SOIC-8 packages. They are specified over $-40^{\circ}C$ to $+125^{\circ}C$ temperature range.

FEATURES

- **Low Offset Voltage: 50 μV (MAX)**
- **Low 0.1Hz to 10Hz Noise: 0.85 μV_{P-P}**
- **Rail-to-Rail Input and Output**
- **Support Single or Dual Power Supplies:
3V to 24V or $\pm 1.5V$ to $\pm 12V$**
- **Quiescent Current: 50 μA /Amplifier (TYP)**
- **$-40^{\circ}C$ to $+125^{\circ}C$ Operating Temperature Range**
- **Small Packaging:
SGM8250-1 Available in Green SOT-23-5, SC70-5 and SOIC-8 Packages
SGM8250-2 Available in Green TDFN-3 \times 3-8L and SOIC-8 Packages**

APPLICATIONS

Temperature Measurements
Medical Instrumentation
Transducer Applications
Electronic Scales
Handheld Test Equipment
Battery-Powered Instruments

PACKAGE/ORDERING INFORMATION

MODEL	PACKAGE DESCRIPTION	SPECIFIED TEMPERATURE RANGE	ORDERING NUMBER	PACKAGE MARKING	PACKING OPTION
SGM8250-1	SOT-23-5	-40°C to +125°C	SGM8250-1XN5G/TR	GSCXX	Tape and Reel, 3000
	SC70-5	-40°C to +125°C	SGM8250-1XC5G/TR	GS3XX	Tape and Reel, 3000
	SOIC-8	-40°C to +125°C	SGM8250-1XS8G/TR	SGM 82501XS8 XXXXX	Tape and Reel, 4000
SGM8250-2	TDFN-3×3-8L	-40°C to +125°C	SGM8250-2XTDB8G/TR	SGM 82502DB XXXXX	Tape and Reel, 4000
	SOIC-8	-40°C to +125°C	SGM8250-2XS8G/TR	SGM 82502XS8 XXXXX	Tape and Reel, 4000

MARKING INFORMATION

NOTE: XX = Date Code. XXXXXX = Date Code and Vendor Code.

SOT-23-5/SC70-5

YYY X X

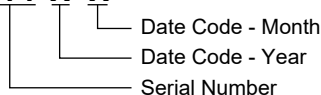

SOIC-8/TDFN-3×3-8L

XXXXX

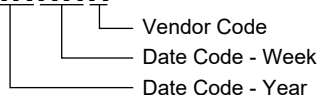

Green (RoHS & HSF): SG Micro Corp defines "Green" to mean Pb-Free (RoHS compatible) and free of halogen substances. If you have additional comments or questions, please contact your SGMICRO representative directly.

ABSOLUTE MAXIMUM RATINGS

Supply Voltage.....	26.4V
Input Common Mode Voltage Range	(-V _S) - 0.3V to (+V _S) + 0.3V
Junction Temperature.....	+150°C
Storage Temperature Range	-65°C to +150°C
Lead Temperature (Soldering, 10s).....	+260°C
ESD Susceptibility	
HBM.....	8000V
MM.....	250V
CDM	1000V

RECOMMENDED OPERATING CONDITIONS

Specified Voltage Range	3V to 24V
Operating Temperature Range	-40°C to +125°C

OVERSTRESS CAUTION

Stresses beyond those listed in Absolute Maximum Ratings may cause permanent damage to the device. Exposure to

absolute maximum rating conditions for extended periods may affect reliability. Functional operation of the device at any conditions beyond those indicated in the Recommended Operating Conditions section is not implied.

ESD SENSITIVITY CAUTION

This integrated circuit can be damaged if ESD protections are not considered carefully. SGMICRO recommends that all integrated circuits be handled with appropriate precautions. Failure to observe proper handling and installation procedures can cause damage. ESD damage can range from subtle performance degradation to complete device failure. Precision integrated circuits may be more susceptible to damage because even small parametric changes could cause the device not to meet the published specifications.

DISCLAIMER

SG Micro Corp reserves the right to make any change in circuit design, or specifications without prior notice.

PIN CONFIGURATIONS

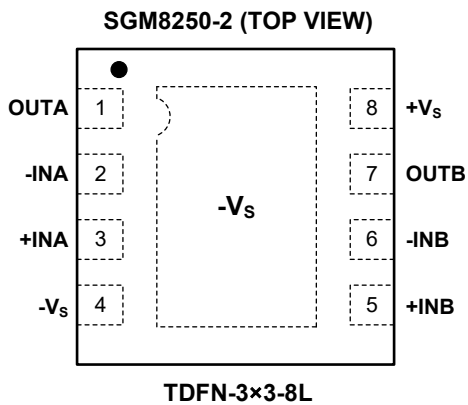
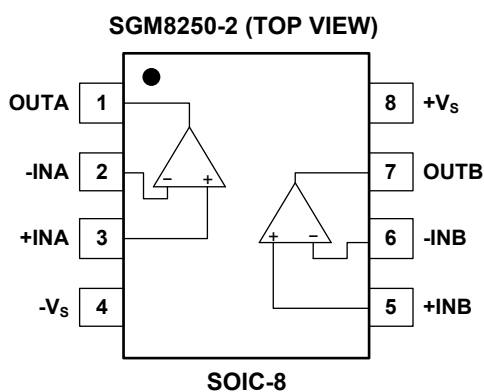
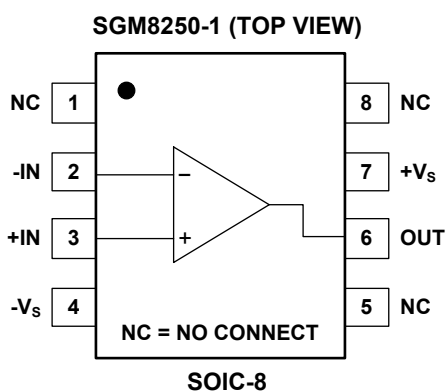
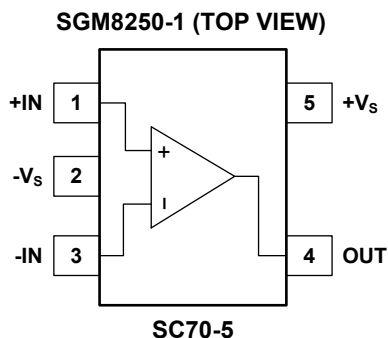
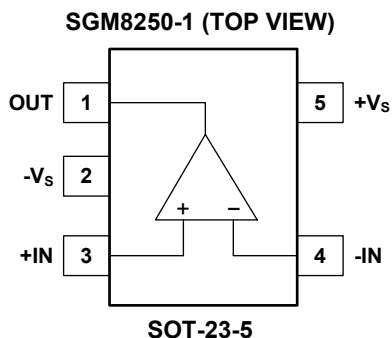

ELECTRICAL CHARACTERISTICS

(At $T_A = +25^\circ\text{C}$, $+V_S = 5\text{V}$, $-V_S = 0\text{V}$, $V_{CM} = +V_S/2$, $V_{OUT} = +V_S/2$ and $R_L = 10\text{k}\Omega$ to $+V_S/2$, Full = -40°C to $+125^\circ\text{C}$, unless otherwise noted.)

PARAMETER	SYMBOL	CONDITIONS	TEMP	MIN	TYP	MAX	UNITS
Input Characteristics							
Input Offset Voltage	V_{OS}		+25°C		10	50	μV
			Full			90	
Input Offset Voltage Drift	$\Delta V_{OS}/\Delta T$		Full		0.11		$\mu\text{V}/^\circ\text{C}$
Input Bias Current	I_B		+25°C		60		pA
Input Common Mode Voltage Range	V_{CM}		Full	$(-V_S) - 0.1$		$(+V_S) + 0.1$	V
Common Mode Rejection Ratio	CMRR	$(-V_S) - 0.1\text{V} < V_{CM} < (+V_S) + 0.1\text{V}$	+25°C	95	112		dB
			Full	92			
Open-Loop Voltage Gain	A_{OL}	$(-V_S) + 0.1\text{V} < V_{OUT} < (+V_S) - 0.1\text{V}$	+25°C	108	131		dB
			Full	105			
Output Characteristics							
Output Voltage Swing from Rail	V_{OH}		+25°C		14	25	mV
			Full			30	
	V_{OL}		+25°C		8	16	
			Full			20	
Output Short-Circuit Current	I_{SC}		+25°C		± 17		mA
Power Supply							
Operating Voltage Range	V_S		Full	3		24	V
Quiescent Current/Amplifier	I_Q	$I_{OUT} = 0$	+25°C		45	60	μA
			Full			80	
Power Supply Rejection Ratio	PSRR	$V_S = 3\text{V to } 24\text{V}$	+25°C	116	142		dB
			Full	113			
Dynamic Performance							
Gain-Bandwidth Product	GBP	$G = +100$, $C_L = 100\text{pF}$	+25°C		350		kHz
Slew Rate	SR	$G = +1$, $V_{OUT} = 2V_{P-P}$, $C_L = 100\text{pF}$	+25°C		0.1		$\text{V}/\mu\text{s}$
Turn-On Time			+25°C		0.75		ms
Noise							
Input Voltage Noise		$f = 0.1\text{Hz to } 10\text{Hz}$	+25°C		0.85		μV_{P-P}
Input Voltage Noise Density	e_n	$f = 1\text{kHz}$	+25°C		40		$\text{nV}/\sqrt{\text{Hz}}$

ELECTRICAL CHARACTERISTICS (continued)

(At $T_A = +25^\circ\text{C}$, $+V_S = 24\text{V}$, $-V_S = 0\text{V}$, $V_{CM} = +V_S/2$, $V_{OUT} = +V_S/2$ and $R_L = 10\text{k}\Omega$ to $+V_S/2$, Full = -40°C to $+125^\circ\text{C}$, unless otherwise noted.)

PARAMETER	SYMBOL	CONDITIONS	TEMP	MIN	TYP	MAX	UNITS
Input Characteristics							
Input Offset Voltage	V_{OS}		+25°C		10	50	μV
			Full			90	
Input Offset Voltage Drift	$\Delta V_{OS}/\Delta T$		Full		0.11		$\mu\text{V}/^\circ\text{C}$
Input Bias Current	I_B		+25°C		80	850	pA
Input Common Mode Voltage Range	V_{CM}		Full	$(-V_S) - 0.1$		$(+V_S) + 0.1$	V
Common Mode Rejection Ratio	CMRR	$(-V_S) - 0.1\text{V} < V_{CM} < (+V_S) + 0.1\text{V}$	+25°C	112	130		dB
			Full	107			
Open-Loop Voltage Gain	A_{OL}	$(-V_S) + 0.1\text{V} < V_{OUT} < (+V_S) - 0.1\text{V}$	+25°C	120	145		dB
			Full	110			
Output Characteristics							
Output Voltage Swing from Rail	V_{OH}		+25°C		65	95	mV
			Full			130	
	V_{OL}		+25°C		37	60	
			Full			85	
Output Short-Circuit Current	I_{SC}		+25°C		± 17		mA
Power Supply							
Operating Voltage Range	V_S		Full	3		24	V
Quiescent Current/Amplifier	I_Q	$I_{OUT} = 0$	+25°C		50	64	μA
			Full			84	
Power Supply Rejection Ratio	PSRR	$V_S = 3\text{V to } 24\text{V}$	+25°C	116	142		dB
			Full	113			
Dynamic Performance							
Gain-Bandwidth Product	GBP	$G = +100, C_L = 100\text{pF}$	+25°C		350		kHz
Slew Rate	SR	$G = +1, V_{OUT} = 2V_{P-P}, C_L = 100\text{pF}$	+25°C		0.09		$\text{V}/\mu\text{s}$
Turn-On Time			+25°C		1.5		ms
Noise							
Input Voltage Noise		$f = 0.1\text{Hz to } 10\text{Hz}$	+25°C		0.85		μV_{P-P}
Input Voltage Noise Density	e_n	$f = 1\text{kHz}$	+25°C		40		$\text{nV}/\sqrt{\text{Hz}}$

TYPICAL PERFORMANCE CHARACTERISTICS

At $T_A = +25^\circ\text{C}$, $+V_S = 5\text{V}$, $-V_S = 0\text{V}$, $R_L = 10\text{k}\Omega$ and $C_L = 0\text{pF}$, unless otherwise noted.

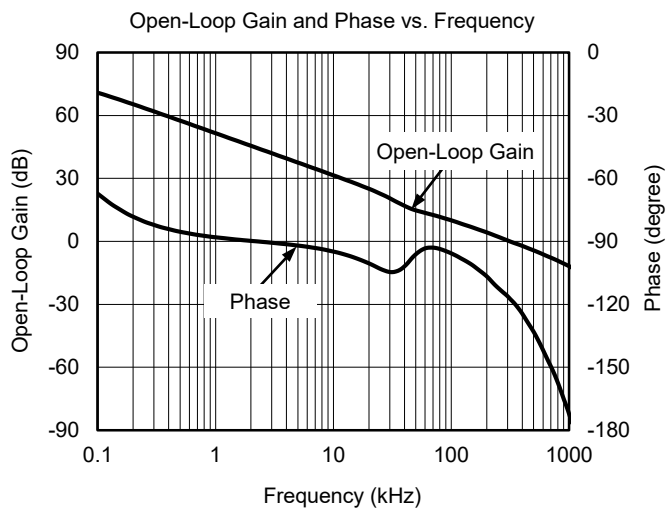
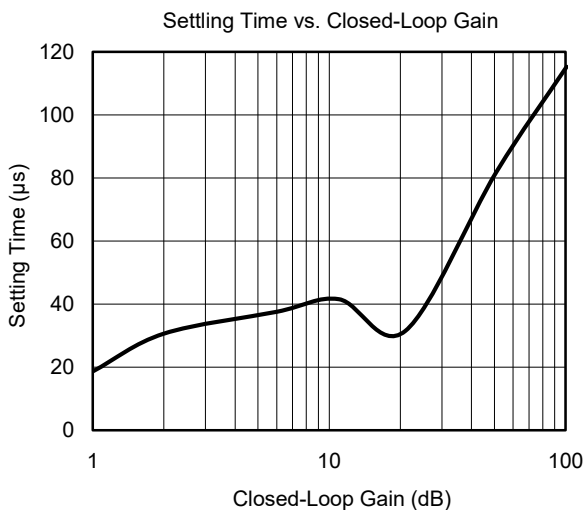
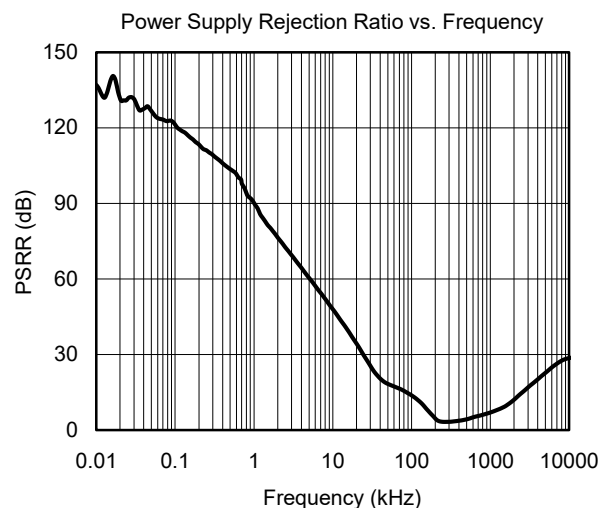
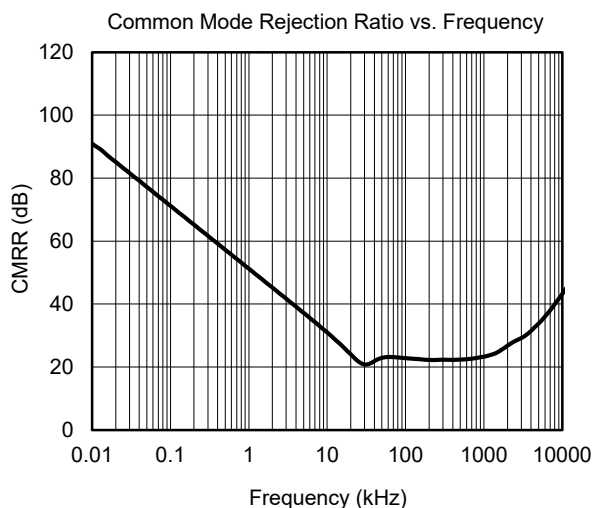
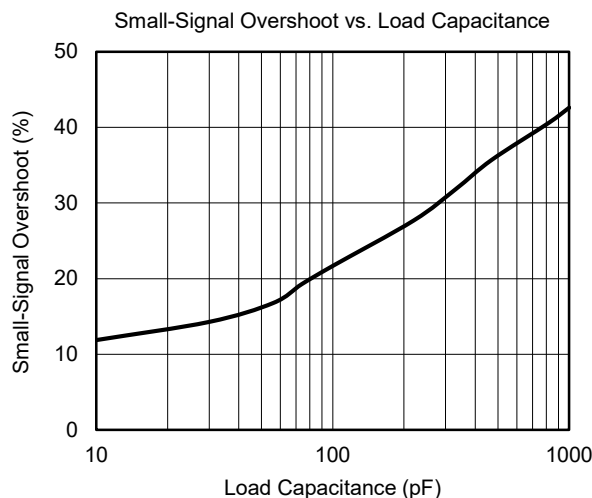
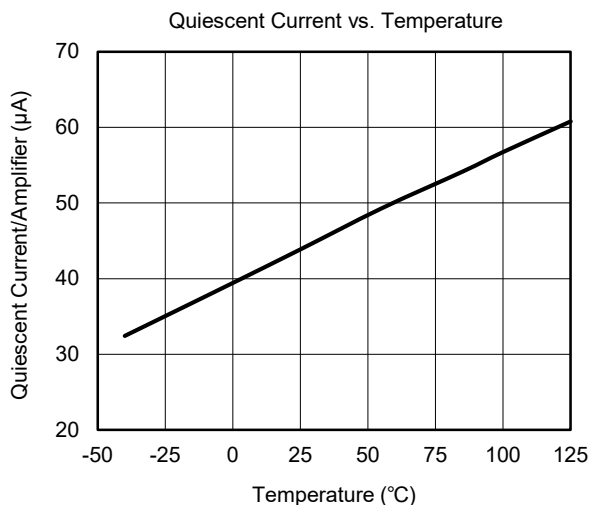

TYPICAL PERFORMANCE CHARACTERISTICS (continued)

At $T_A = +25^\circ\text{C}$, $+V_S = 5\text{V}$, $-V_S = 0\text{V}$, $R_L = 10\text{k}\Omega$ and $C_L = 0\text{pF}$, unless otherwise noted.

Large-Signal Step Response

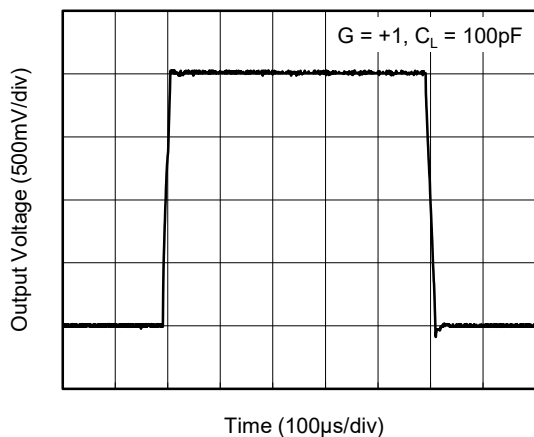

Small-Signal Step Response

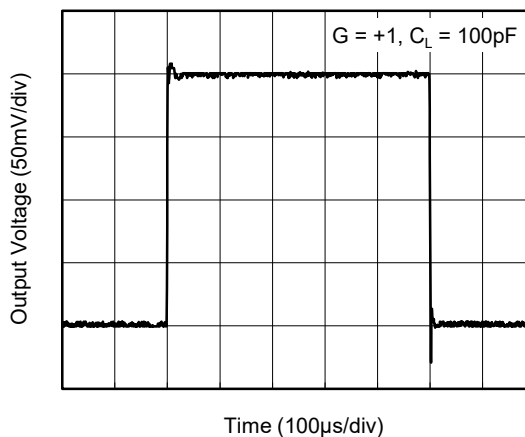

Positive Overload Recovery

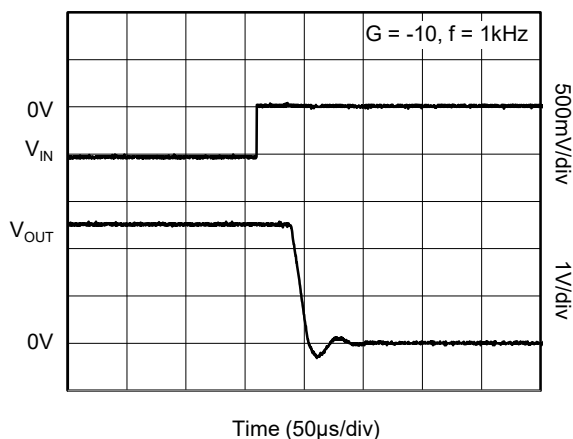

Negative Overload Recovery

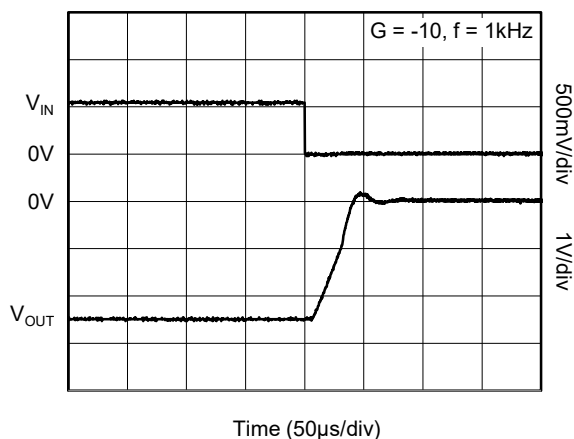

Turn-On Time

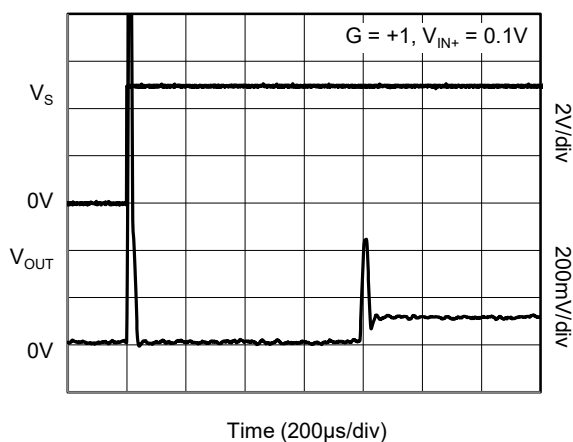

0.1Hz to 10Hz Noise

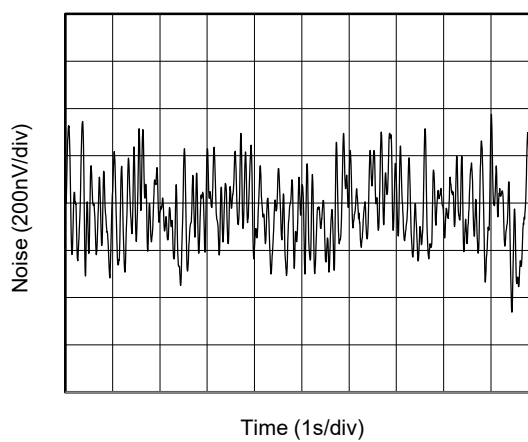

TYPICAL PERFORMANCE CHARACTERISTICS (continued)

At $T_A = +25^\circ\text{C}$, $+V_S = 5\text{V}$, $-V_S = 0\text{V}$, $R_L = 10\text{k}\Omega$ and $C_L = 0\text{pF}$, unless otherwise noted.

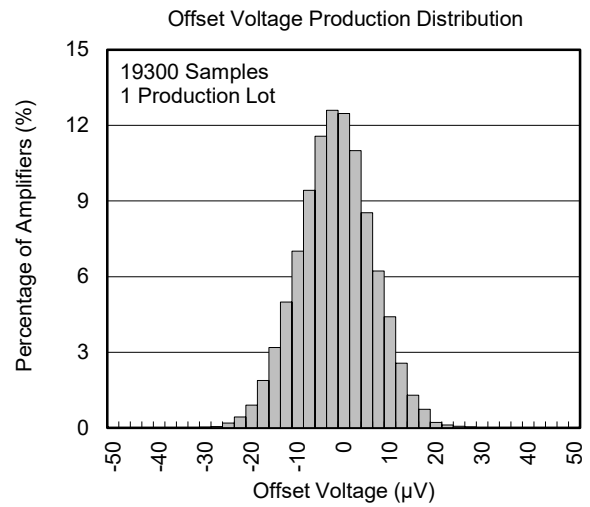
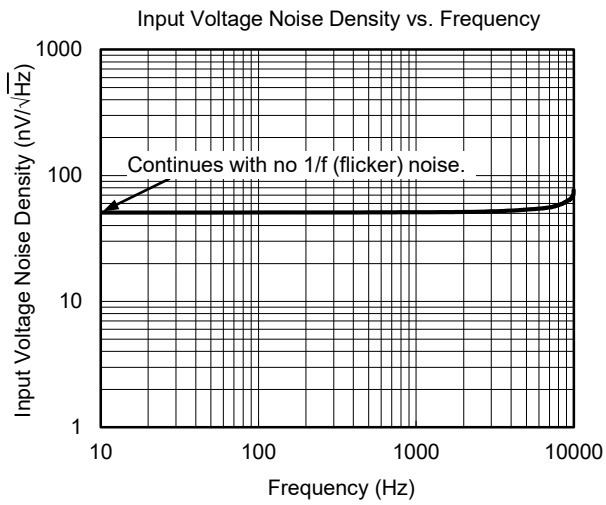

REVISION HISTORY

NOTE: Page numbers for previous revisions may differ from page numbers in the current version.

Changes from Original (DECEMBER 2017) to REV.A

Page

Changed from product preview to production data.....All

PACKAGE INFORMATION

PACKAGE OUTLINE DIMENSIONS

SOT-23-5

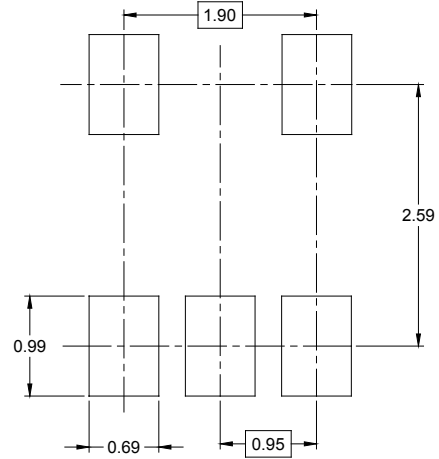
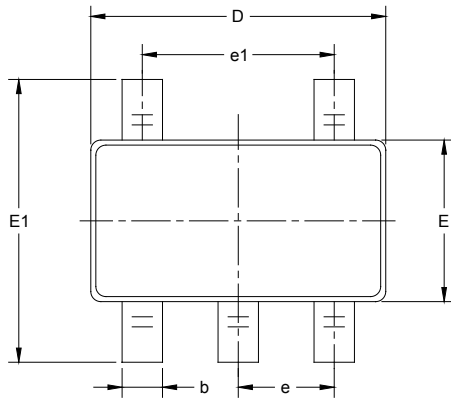

RECOMMENDED LAND PATTERN (Unit: mm)

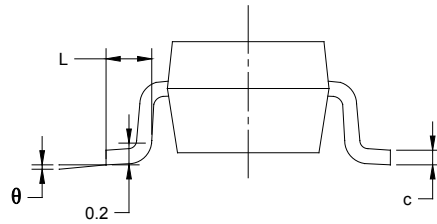
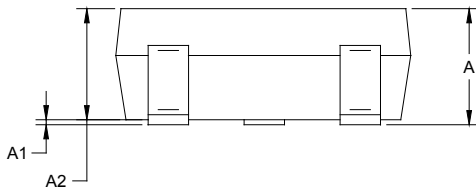

Symbol	Dimensions In Millimeters		Dimensions In Inches	
	MIN	MAX	MIN	MAX
A	1.050	1.250	0.041	0.049
A1	0.000	0.100	0.000	0.004
A2	1.050	1.150	0.041	0.045
b	0.300	0.500	0.012	0.020
c	0.100	0.200	0.004	0.008
D	2.820	3.020	0.111	0.119
E	1.500	1.700	0.059	0.067
E1	2.650	2.950	0.104	0.116
e	0.950 BSC		0.037 BSC	
e1	1.900 BSC		0.075 BSC	
L	0.300	0.600	0.012	0.024
θ	0°	8°	0°	8°

PACKAGE OUTLINE DIMENSIONS

SC70-5

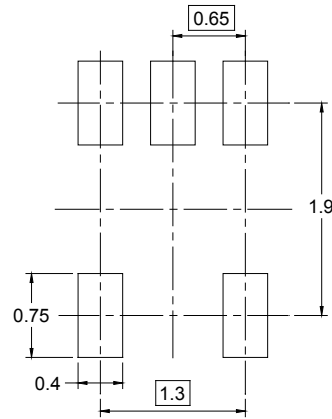
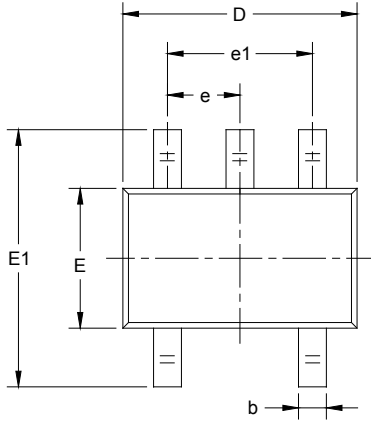

RECOMMENDED LAND PATTERN (Unit: mm)

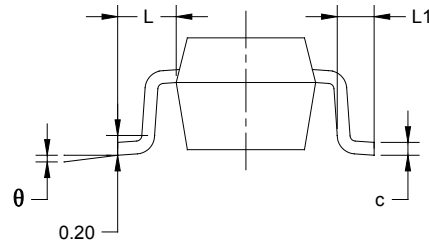
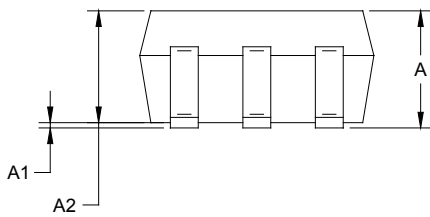

Symbol	Dimensions In Millimeters		Dimensions In Inches	
	MIN	MAX	MIN	MAX
A	0.900	1.100	0.035	0.043
A1	0.000	0.100	0.000	0.004
A2	0.900	1.000	0.035	0.039
b	0.150	0.350	0.006	0.014
c	0.080	0.150	0.003	0.006
D	2.000	2.200	0.079	0.087
E	1.150	1.350	0.045	0.053
E1	2.150	2.450	0.085	0.096
e	0.65 TYP		0.026 TYP	
e1	1.300 BSC		0.051 BSC	
L	0.525 REF		0.021 REF	
L1	0.260	0.460	0.010	0.018
theta	0°	8°	0°	8°

PACKAGE OUTLINE DIMENSIONS

TDFN-3x3-8L

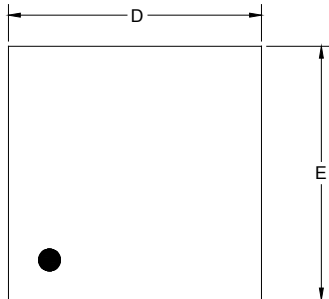

TOP VIEW

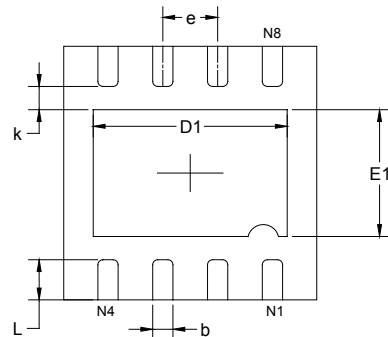

BOTTOM VIEW

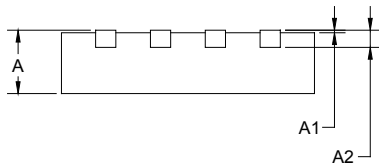

SIDE VIEW

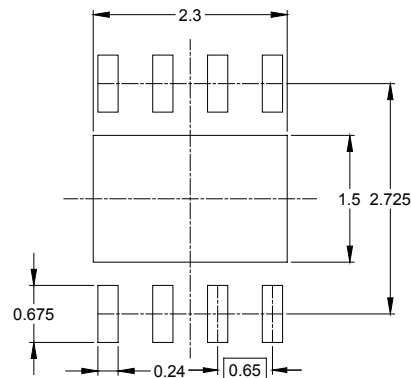

RECOMMENDED LAND PATTERN (Unit: mm)

Symbol	Dimensions In Millimeters		Dimensions In Inches	
	MIN	MAX	MIN	MAX
A	0.700	0.800	0.028	0.031
A1	0.000	0.050	0.000	0.002
A2	0.203 REF		0.008 REF	
D	2.900	3.100	0.114	0.122
D1	2.200	2.400	0.087	0.094
E	2.900	3.100	0.114	0.122
E1	1.400	1.600	0.055	0.063
k	0.200 MIN		0.008 MIN	
b	0.180	0.300	0.007	0.012
e	0.650 TYP		0.026 TYP	
L	0.375	0.575	0.015	0.023

PACKAGE OUTLINE DIMENSIONS

SOIC-8

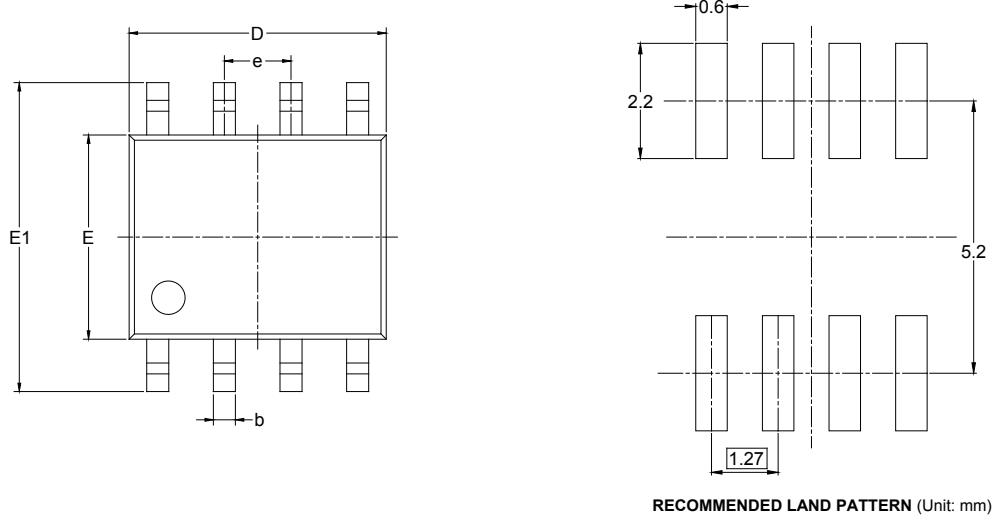

Symbol	Dimensions In Millimeters		Dimensions In Inches	
	MIN	MAX	MIN	MAX
A	1.350	1.750	0.053	0.069
A1	0.100	0.250	0.004	0.010
A2	1.350	1.550	0.053	0.061
b	0.330	0.510	0.013	0.020
c	0.170	0.250	0.006	0.010
D	4.700	5.100	0.185	0.200
E	3.800	4.000	0.150	0.157
E1	5.800	6.200	0.228	0.244
e	1.27 BSC		0.050 BSC	
L	0.400	1.270	0.016	0.050
θ	0°	8°	0°	8°

PACKAGE INFORMATION

TAPE AND REEL INFORMATION

REEL DIMENSIONS

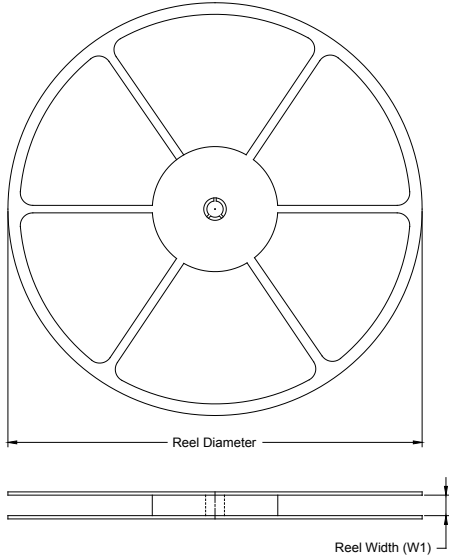

TAPE DIMENSIONS

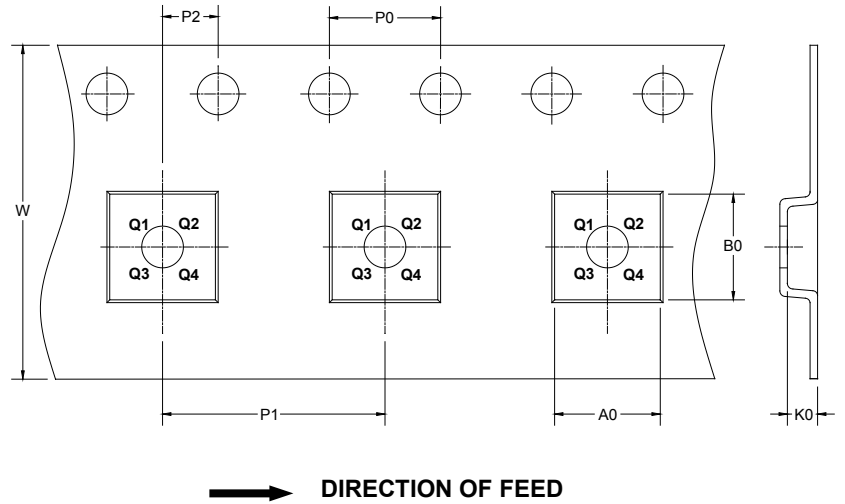

NOTE: The picture is only for reference. Please make the object as the standard.

KEY PARAMETER LIST OF TAPE AND REEL

Package Type	Reel Diameter	Reel Width W1 (mm)	A0 (mm)	B0 (mm)	K0 (mm)	P0 (mm)	P1 (mm)	P2 (mm)	W (mm)	Pin1 Quadrant
SOT-23-5	7"	9.5	3.20	3.20	1.40	4.0	4.0	2.0	8.0	Q3
SC70-5	7"	9.5	2.25	2.55	1.20	4.0	4.0	2.0	8.0	Q3
TDFN-3×3-8L	13"	12.4	3.35	3.35	1.13	4.0	8.0	2.0	12.0	Q1
SOIC-8	13"	12.4	6.40	5.40	2.10	4.0	8.0	2.0	12.0	Q1

DD0001

PACKAGE INFORMATION

CARTON BOX DIMENSIONS



NOTE: The picture is only for reference. Please make the object as the standard.

KEY PARAMETER LIST OF CARTON BOX

Reel Type	Length (mm)	Width (mm)	Height (mm)	Pizza/Carton
7" (Option)	368	227	224	8
7"	442	410	224	18
13"	386	280	370	5

DD0002

单击下面可查看定价，库存，交付和生命周期等信息

[>>SGMICRO\(圣邦微电子\)](#)