



# SGM41002 Battery Protection IC for 2-Serial to 4-Serial-Cell Pack (Secondary Protection)

## GENERAL DESCRIPTION

The SGM41002 is designed for secondary protection of Li-Ion rechargeable cells. The product integrates a high-accuracy voltage detection circuit and a delay circuit required for safe operation of Li-Ion rechargeable cells.

The SGM41002 is available in a Green UTDFN-2×2.5-8L package and operates in -40°C to +85°C temperature range.

## APPLICATIONS

Li-Ion Rechargeable Battery Packs

## FEATURES

- **Charge Over-Voltage Protection Thresholds: 4.35V, 4.45V, 4.5V**
- **-0.4V Over-Charge Hysteresis Voltage**
- **Wide Power Supply Voltage Range: 3.6V to 24V**
- **2.8s Delay Time for Over-Charge Detection**
- **26V Absolute Maximum Rating**
- **Output Control through CTL Pin**
- **CMOS Output Logic Level: Active High**
- **Low Power Consumption**
- **Operating Temperature Range: -40°C to +85°C**
- **Available in a Green UTDFN-2×2.5-8L Package**

## DEVICE DESCRIPTION

Model	Over-Charge Detection Voltage (V <sub>CU</sub> )	Over-Charge Hysteresis Voltage (V <sub>HC</sub> )	Over-Charge Detection Delay Time (t <sub>CU</sub> )	Function
SGM41002	4.35V	-0.4V	2.8s	CMOS output active "H"
	4.45V	-0.4V	2.8s	CMOS output active "H"
	4.5V	-0.4V	2.8s	CMOS output active "H"

**PACKAGE/ORDERING INFORMATION**

MODEL	PACKAGE DESCRIPTION	SPECIFIED TEMPERATURE RANGE	ORDERING NUMBER	PACKAGE MARKING	PACKING OPTION
SGM41002	UTDFN-2x2.5-8L	-40°C to +85°C	SGM41002-4.35YUDS8G/TR	GY5 XXXX	Tape and Reel, 3000
	UTDFN-2x2.5-8L	-40°C to +85°C	SGM41002-4.45YUDS8G/TR	GNC XXXX	Tape and Reel, 3000
	UTDFN-2x2.5-8L	-40°C to +85°C	SGM41002-4.50YUDS8G/TR	GNB XXXX	Tape and Reel, 3000

NOTE: XXXX = Date Code.

Green (RoHS & HSF): SG Micro Corp defines "Green" to mean Pb-Free (RoHS compatible) and free of halogen substances. If you have additional comments or questions, please contact your SGMICRO representative directly.

**ABSOLUTE MAXIMUM RATINGS**

Input Voltage Range (between VDD and VSS)  
 .....  $V_{SS} - 0.3V$  to  $V_{SS} + 26V$   
 Input Pin Voltage Range, VC1, VC2, VC3, VC4, CTL  
 .....  $V_{SS} - 0.3V$  to  $V_{DD} + 0.3V$   
 Output Pin Voltage Range, CO .....  $V_{SS} - 0.3V$  to  $V_{DD} + 0.3V$   
 Junction Temperature ..... +150°C  
 Storage Temperature Range ..... -65°C to +150°C  
 Lead Temperature (Soldering, 10s) ..... +260°C  
 ESD Susceptibility  
 HBM ..... 2000V  
 MM ..... 200V  
 CDM ..... 1000V

**RECOMMENDED OPERATING CONDITIONS**

Supply Voltage Range ..... 4V to 24V  
 Battery Voltage Range ..... 0V to 24V  
 Environmental Temperature Range ..... -40°C to +85°C

**OVERSTRESS CAUTION**

Stresses beyond those listed in Absolute Maximum Ratings may cause permanent damage to the device. Exposure to absolute maximum rating conditions for extended periods may affect reliability. Functional operation of the device at any conditions beyond those indicated in the Recommended Operating Conditions section is not implied.

**ESD SENSITIVITY CAUTION**

This integrated circuit can be damaged if ESD protections are not considered carefully. SGMICRO recommends that all integrated circuits be handled with appropriate precautions. Failure to observe proper handling and installation procedures can cause damage. ESD damage can range from subtle performance degradation to complete device failure. Precision integrated circuits may be more susceptible to damage because even small parametric changes could cause the device not to meet the published specifications.

**DISCLAIMER**

SG Micro Corp reserves the right to make any change in circuit design, or specifications without prior notice.

PIN CONFIGURATION

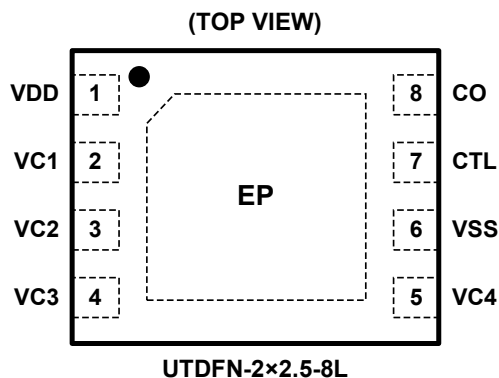

PIN DESCRIPTION

PIN	NAME	FUNCTION
1	VDD	Positive Power Input Pin.
2	VC1	Positive Voltage Connection Pin of Battery 1.
3	VC2	Positive Voltage Connection Pin of Battery 2, Negative Voltage Connection Pin of Battery 1.
4	VC3	Positive Voltage Connection Pin of Battery 3, Negative Voltage Connection Pin of Battery 2.
5	VC4	Positive Voltage Connection Pin of Battery 4, Negative Voltage Connection Pin of Battery 3.
6	VSS	Negative Power Input Pin, Negative Voltage Connection Pin of Battery 4.
7	CTL	CO Output Control Pin.
8	CO	FET Gate Connection Pin for Charge.
Exposed Pad	EP	Negative Power Input Pin, Negative Voltage Connection Pin of Battery 4.

## ELECTRICAL CHARACTERISTICS

(T<sub>A</sub> = +25°C, unless otherwise noted.)

PARAMETER	SYMBOL	CONDITIONS	MIN	TYP	MAX	UNITS
<b>Detection Voltage</b>						
Over-Charge Detection Voltage n (n = 1, 2, 3, 4)	V <sub>CU<sub>n</sub></sub>	SGM41002-4.35	4.314	4.35	4.386	V
		SGM41002-4.45	4.414	4.45	4.486	V
		SGM41002-4.5	4.464	4.5	4.536	V
Over-Charge Hysteresis Voltage n (n = 1, 2, 3, 4)	V <sub>HCU<sub>n</sub></sub>		-0.422	-0.4	-0.378	V
<b>Input Voltage</b>						
Operating Voltage between VDD and VSS	V <sub>DSOP</sub>			14	24	V
CTL Pin Input High Voltage	V <sub>CTLH</sub>		V <sub>DD</sub> × 0.95			V
CTL Pin Input Low Voltage	V <sub>CTLL</sub>				V <sub>DD</sub> × 0.4	V
<b>Input Current</b>						
Current Consumption during Operation	I <sub>OPE</sub>	V1 = V2 = V3 = V4 = 3.5V		2.4	3.5	μA
Current Consumption during Over-Discharge	I <sub>OPE<sub>D</sub></sub>	V1 = V2 = V3 = V4 = 2.3V		2.2	3	μA
VC1 Pin Current	I <sub>VC1</sub>	V1 = V2 = V3 = V4 = 3.5V		0.6	1	μA
VC2 Pin Current	I <sub>VC2</sub>		-0.5	0.005	0.5	μA
VC3 Pin Current	I <sub>VC3</sub>		-0.5	0.005	0.5	μA
VC4 Pin Current	I <sub>VC4</sub>		-0.5	0.005	0.5	μA
CTL Pin Input High Current	I <sub>CTLH</sub>	V1 = V2 = V3 = V4 = 3.5V, V <sub>CTL</sub> = V <sub>DD</sub>	0.8	1.2	1.4	μA
CTL Pin Input Low Current	I <sub>CTLL</sub>	V1 = V2 = V3 = V4 = 3.5V, V <sub>CTL</sub> = 0V	-0.5		0.5	μA
<b>Output Current</b>						
CO Pin Sink Current	I <sub>COL</sub>	V <sub>CO</sub> = V <sub>SS</sub> + 0.5V	0.06	0.1		mA
CO Pin Source Current	I <sub>COH</sub>	V <sub>CO</sub> = V <sub>DD</sub> - 0.5V	22	30		μA
<b>Delay Time</b>						
Over-Charge Detection Delay Time	t <sub>CU</sub>		1.5	2.8	4.1	s
Over-Charge Timer Reset Delay Time	t <sub>TR</sub>		1.6	9.8	19.2	ms
Over-Charge Release Delay Time	t <sub>CL</sub>		12.8	45.8	83.2	ms
CTL Pin Response Time	t <sub>CTL</sub>		1.5	2.5	3.5	ms

**REVISION HISTORY**

NOTE: Page numbers for previous revisions may differ from page numbers in the current version.

**Changes from Original (SEPTEMBER 2017) to REV.A**

---

Changed from product preview to production data.....All

---

PACKAGE OUTLINE DIMENSIONS

UTDFN-2×2.5-8L

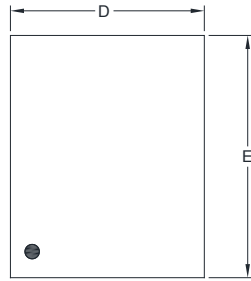

TOP VIEW

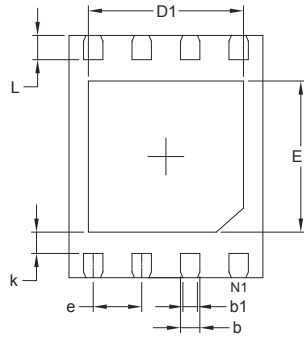

BOTTOM VIEW

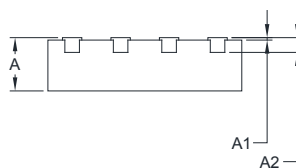

SIDE VIEW

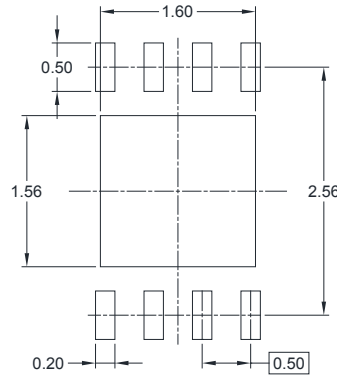

RECOMMENDED LAND PATTERN (Unit: mm)

Symbol	Dimensions In Millimeters		Dimensions In Inches	
	MIN	MAX	MIN	MAX
A	0.500	0.600	0.020	0.024
A1	0.000	0.050	0.000	0.002
A2	0.152 REF		0.006 REF	
D	1.900	2.100	0.075	0.083
D1	1.500	1.700	0.059	0.067
E	2.400	2.600	0.094	0.102
E1	1.460	1.660	0.057	0.065
b	0.150	0.250	0.006	0.010
b1	0.150 REF		0.006 REF	
e	0.500 BSC		0.020 BSC	
k	0.220 REF		0.009 REF	
L	0.174	0.326	0.007	0.013

# PACKAGE INFORMATION

## TAPE AND REEL INFORMATION

### REEL DIMENSIONS

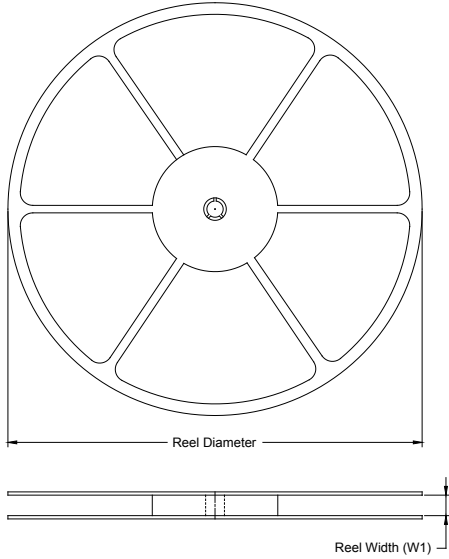

### TAPE DIMENSIONS

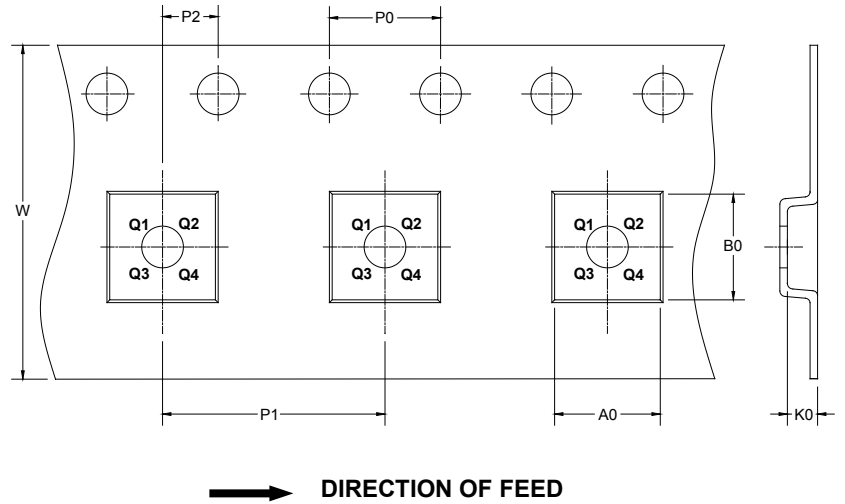

NOTE: The picture is only for reference. Please make the object as the standard.

### KEY PARAMETER LIST OF TAPE AND REEL

Package Type	Reel Diameter	Reel Width W1 (mm)	A0 (mm)	B0 (mm)	K0 (mm)	P0 (mm)	P1 (mm)	P2 (mm)	W (mm)	Pin1 Quadrant
UTDFN-2x2.5-8L	7"	9.0	2.25	2.75	0.70	4.0	4.0	2.0	8.0	Q2

000001

# PACKAGE INFORMATION

## CARTON BOX DIMENSIONS



NOTE: The picture is only for reference. Please make the object as the standard.

## KEY PARAMETER LIST OF CARTON BOX

Reel Type	Length (mm)	Width (mm)	Height (mm)	Pizza/Carton
7" (Option)	368	227	224	8
7"	442	410	224	18

DD0002



单击下面可查看定价，库存，交付和生命周期等信息

[>>SGMICRO\(圣邦微电子\)](#)