



# SGM8199

## Voltage Output, High-side or Low-side Measurement, Bi-Directional Current Shunt Monitor

### GENERAL DESCRIPTION

The SGM8199 is a current shunt monitor that operates from 2.7V to 26V single supply, consuming only 85 $\mu$ A quiescent current. The device features a wide common mode voltage range from -0.1V to 26V. It can detect voltage drops across shunt resistors without being affected by the supply voltage.

The SGM8199 provides three fixed gains: 20V/V, 50V/V and 100V/V. The device offers a low offset, which allows 10mV full-scale maximum drops across the shunt when sensing current.

The SGM8199 series are available in a Green SC70-6 package. They are specified over the extended -40°C to +125°C temperature range.

### APPLICATIONS

Portable Equipment  
Computers  
Battery Chargers  
Energy Managements  
Telecom Equipment

### FEATURES

- **Wide Input Common Mode Voltage: -0.1V to 26V**
- **Low Quiescent Current: 85 $\mu$ A (TYP)**
- **Low Input Offset Voltage:**
  - SGM8199A0: 600 $\mu$ V ( $V_{CM} = 12V$ , MAX)**
  - SGM8199A1: 350 $\mu$ V ( $V_{CM} = 12V$ , MAX)**
  - SGM8199A2: 250 $\mu$ V ( $V_{CM} = 12V$ , MAX)****(Enable 10mV Full-Scale Shunt Drops)**
- **Gain Options:**
  - SGM8199A0 Gain: 20V/V**
  - SGM8199A1 Gain: 50V/V**
  - SGM8199A2 Gain: 100V/V**
- **Gain Error:**
  - SGM8199A0:  $\pm 0.7\%$  (MAX)**
  - SGM8199A1:  $\pm 0.4\%$  (MAX)**
  - SGM8199A2:  $\pm 0.4\%$  (MAX)**
- **-40°C to +125°C Operating Temperature Range**
- **Available in a Green SC70-6 Package**

# Voltage Output, High-side or Low-side Measurement, Bi-Directional Current Shunt Monitor

## SGM8199

### PACKAGE/ORDERING INFORMATION

MODEL	PACKAGE DESCRIPTION	GAIN	SPECIFIED TEMPERATURE RANGE	ORDERING NUMBER	PACKAGE MARKING	PACKING OPTION
SGM8199A0	SC70-6	20V/V	-40°C to +125°C	SGM8199A0XC6G/TR	M91XX	Tape and Reel, 3000
SGM8199A1	SC70-6	50V/V	-40°C to +125°C	SGM8199A1XC6G/TR	GS2XX	Tape and Reel, 3000
SGM8199A2	SC70-6	100V/V	-40°C to +125°C	SGM8199A2XC6G/TR	M93XX	Tape and Reel, 3000

### MARKING INFORMATION

NOTE: XX = Date Code.

YYY X X

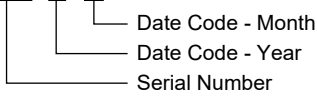

Green (RoHS & HSF): SG Micro Corp defines "Green" to mean Pb-Free (RoHS compatible) and free of halogen substances. If you have additional comments or questions, please contact your SGMICRO representative directly.

### ABSOLUTE MAXIMUM RATINGS

Supply Voltage.....	28V
V <sub>IN</sub> Differential.....	±28V
Input Common Mode Voltage Range.....	GND - 0.3V to 28V
Input Current into All Pins.....	5mA
Junction Temperature.....	+150°C
Storage Temperature Range.....	-65°C to +150°C
Lead Temperature (Soldering, 10s).....	+260°C
ESD Susceptibility	
HBM.....	3000V
MM.....	200V
CDM.....	2000V

integrated circuits be handled with appropriate precautions. Failure to observe proper handling and installation procedures can cause damage. ESD damage can range from subtle performance degradation to complete device failure. Precision integrated circuits may be more susceptible to damage because even small parametric changes could cause the device not to meet the published specifications.

### DISCLAIMER

SG Micro Corp reserves the right to make any change in circuit design, or specifications without prior notice.

### RECOMMENDED OPERATING CONDITIONS

Operating Temperature Range.....	-40°C to +125°C
----------------------------------	-----------------

### OVERSTRESS CAUTION

Stresses beyond those listed in Absolute Maximum Ratings may cause permanent damage to the device. Exposure to absolute maximum rating conditions for extended periods may affect reliability. Functional operation of the device at any conditions beyond those indicated in the Recommended Operating Conditions section is not implied.

### ESD SENSITIVITY CAUTION

This integrated circuit can be damaged if ESD protections are not considered carefully. SGMICRO recommends that all

### PIN CONFIGURATION

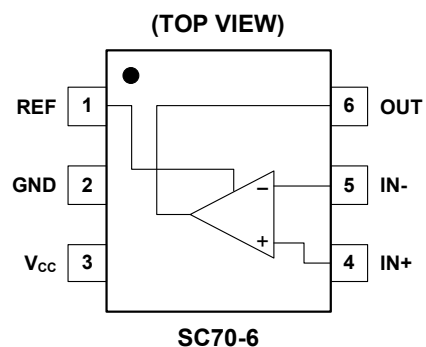

# Voltage Output, High-side or Low-side Measurement, Bi-Directional Current Shunt Monitor

## SGM8199

### ELECTRICAL CHARACTERISTICS

(At T<sub>A</sub> = +25°C, Full = -40°C to +125°C, V<sub>CC</sub> = 2.7V to 26V, V<sub>IN+</sub> = 12V, V<sub>SENSE</sub> = V<sub>IN+</sub> - V<sub>IN-</sub>, and V<sub>REF</sub> = V<sub>CC</sub>/2, unless otherwise noted.)

PARAMETER	CONDITIONS		TEMP	MIN	TYP	MAX	UNITS
<b>Input Characteristics</b>							
Input Offset Voltage, RTI <sup>(1)</sup> (V <sub>OS</sub> )	V <sub>CM</sub> = -0.1V to 2V, V <sub>SENSE</sub> = 0mV	SGM8199A0	+25°C		270	1420	μV
	V <sub>CM</sub> = 2V to 26V, V <sub>SENSE</sub> = 0mV				260	600	
	V <sub>CM</sub> = -0.1V to 2V, V <sub>SENSE</sub> = 0mV	SGM8199A1			150	720	
	V <sub>CM</sub> = 2V to 26V, V <sub>SENSE</sub> = 0mV				150	350	
	V <sub>CM</sub> = -0.1V to 2V, V <sub>SENSE</sub> = 0mV	SGM8199A2			80	750	
	V <sub>CM</sub> = 2V to 26V, V <sub>SENSE</sub> = 0mV				80	250	
Input Offset Voltage Drift (ΔV <sub>OS</sub> /ΔT)			Full		1		μV/°C
Input Bias Current (I <sub>b</sub> )	V <sub>SENSE</sub> = 0mV	SGM8199A0	+25°C		30		μA
		SGM8199A1/ SGM8199A2			16		
Input Offset Current (I <sub>OS</sub> )	V <sub>SENSE</sub> = 0mV	SGM8199A0	+25°C		35		nA
		SGM8199A1/ SGM8199A2			25		
Input Common Mode Voltage Range (V <sub>CM</sub> )			Full	-0.1		26	V
Common Mode Rejection Ratio (CMRR)	V <sub>CM</sub> = -0.1V to 26V, V <sub>SENSE</sub> = 0mV	SGM8199A0	Full		85	97	dB
	V <sub>CM</sub> = 2V to 26V, V <sub>SENSE</sub> = 0mV				81	93	
	V <sub>CM</sub> = -0.1V to 26V, V <sub>SENSE</sub> = 0mV	SGM8199A1			85	104	
	V <sub>CM</sub> = 2V to 26V, V <sub>SENSE</sub> = 0mV				87	100	
	V <sub>CM</sub> = -0.1V to 26V, V <sub>SENSE</sub> = 0mV	SGM8199A2			90	108	
	V <sub>CM</sub> = 2V to 26V, V <sub>SENSE</sub> = 0mV				91	106	
<b>Output Characteristics</b>							
Gain (G)			+25°C		20		V/V
					50		
					100		
Gain Error	V <sub>SENSE</sub> = -5mV to 5mV	SGM8199A0	Full		0.20	0.7	%
		SGM8199A1			0.02	0.4	
		SGM8199A2			0.05	0.4	
Gain Temperature Coefficient			Full		10		ppm/°C
Nonlinearity Error	V <sub>SENSE</sub> = -5mV to 5mV		+25°C		0.01		%
Maximum Capacitive Load	No sustained oscillation		+25°C		1		nF
Output Voltage Swing from Rail	V <sub>OH</sub>	V <sub>CC</sub> = 26V, R <sub>L</sub> = 10kΩ to V <sub>CC</sub> /2	Full		140	380	mV
	V <sub>OL</sub>				85	300	

NOTE: 1. RTI = Referred-to-input.

# Voltage Output, High-side or Low-side Measurement, SGM8199 Bi-Directional Current Shunt Monitor

## ELECTRICAL CHARACTERISTICS (continued)

(At  $T_A = +25^\circ\text{C}$ , Full =  $-40^\circ\text{C}$  to  $+125^\circ\text{C}$ ,  $V_{CC} = 2.7\text{V}$  to  $26\text{V}$ ,  $V_{IN+} = 12\text{V}$ ,  $V_{SENSE} = V_{IN+} - V_{IN-}$ , and  $V_{REF} = V_{CC}/2$ , unless otherwise noted.)

PARAMETER	CONDITIONS	TEMP	MIN	TYP	MAX	UNITS
<b>Dynamic Performance</b>						
-3dB Bandwidth	$V_{CC} = 5\text{V}$ , $R_L = 10\text{k}\Omega$ , $C_L = 10\text{pF}$	SGM8199A0	$+25^\circ\text{C}$	74		kHz
		SGM8199A1		80		
		SGM8199A2		68		
Slew Rate (SR)	$f = 1\text{kHz}$ , $R_L = 10\text{k}\Omega$ , $V_{OUT} = 1V_{P-P}$	SGM8199A0	$+25^\circ\text{C}$	0.42		V/ $\mu\text{s}$
	$f = 1\text{kHz}$ , $R_L = 10\text{k}\Omega$ , $V_{OUT} = 2V_{P-P}$	SGM8199A0		0.42		
	$f = 1\text{kHz}$ , $R_L = 10\text{k}\Omega$ , $V_{OUT} = 1V_{P-P}$	SGM8199A1		0.15		
	$f = 1\text{kHz}$ , $R_L = 10\text{k}\Omega$ , $V_{OUT} = 2V_{P-P}$	SGM8199A1		0.35		
	$f = 1\text{kHz}$ , $R_L = 10\text{k}\Omega$ , $V_{OUT} = 1V_{P-P}$	SGM8199A2		0.12		
	$f = 1\text{kHz}$ , $R_L = 10\text{k}\Omega$ , $V_{OUT} = 2V_{P-P}$	SGM8199A2		0.3		
<b>Noise, RTI <sup>(1)</sup></b>						
Voltage Noise Density ( $e_n$ )	$f = 1\text{kHz}$	SGM8199A0	$+25^\circ\text{C}$	48		nV/ $\sqrt{\text{Hz}}$
		SGM8199A1		50		
		SGM8199A2		35		
<b>Power Supply</b>						
Operating Voltage Range ( $V_{CC}$ )		Full	2.7		26	V
Quiescent Current ( $I_Q$ )	$V_{CC} = 26\text{V}$ , $V_{SENSE} = 0\text{mV}$	$+25^\circ\text{C}$		85	120	$\mu\text{A}$
		Full			130	
Power Supply Rejection Ratio (PSRR)	$V_{CC} = 2.7\text{V}$ to $26\text{V}$ , $V_{SENSE} = 0\text{mV}$	SGM8199A0	$+25^\circ\text{C}$	100		dB
		SGM8199A1/		105		
		SGM8199A2				

NOTE: 1. RTI = Referred-to-input.

# SGM8199 Voltage Output, High-side or Low-side Measurement, Bi-Directional Current Shunt Monitor

## TYPICAL PERFORMANCE CHARACTERISTICS

Performance measured with the SGM8199A1 at  $T_A = +25^\circ\text{C}$ ,  $V_{CC} = 5\text{V}$ ,  $\text{GND} = 0\text{V}$ ,  $V_{IN+} = 12\text{V}$ ,  $V_{SENSE} = V_{IN+} - V_{IN-}$  and  $V_{REF} = V_{CC}/2$ , unless otherwise noted.

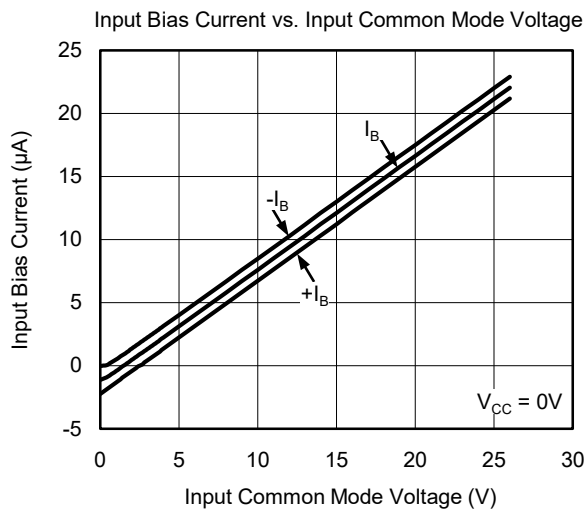
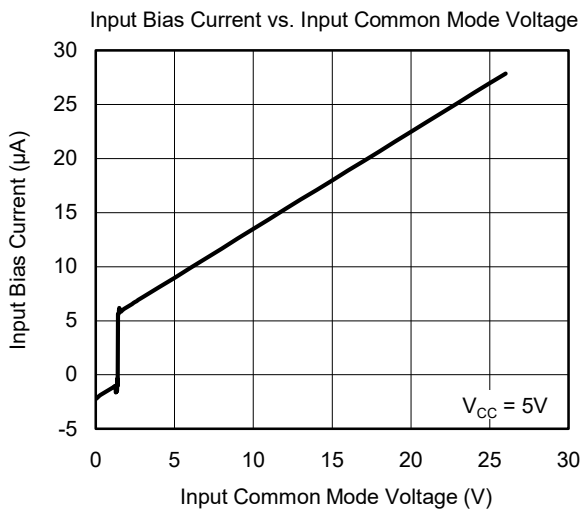
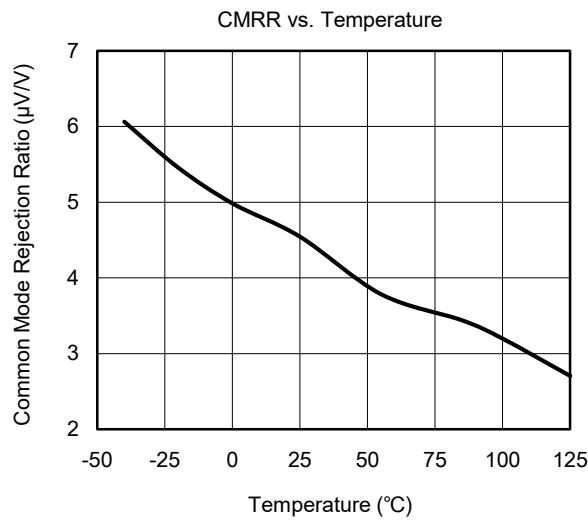
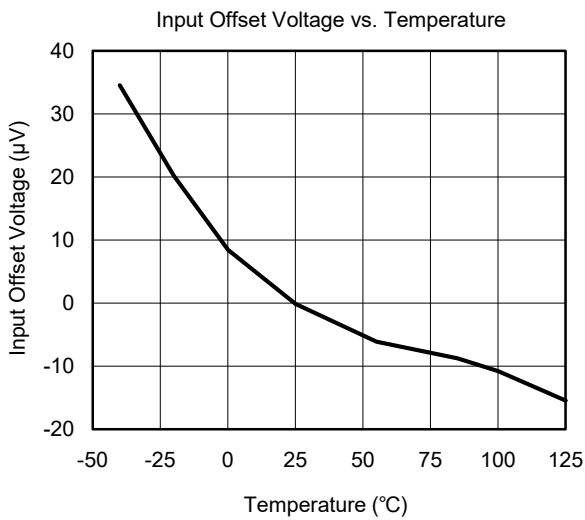
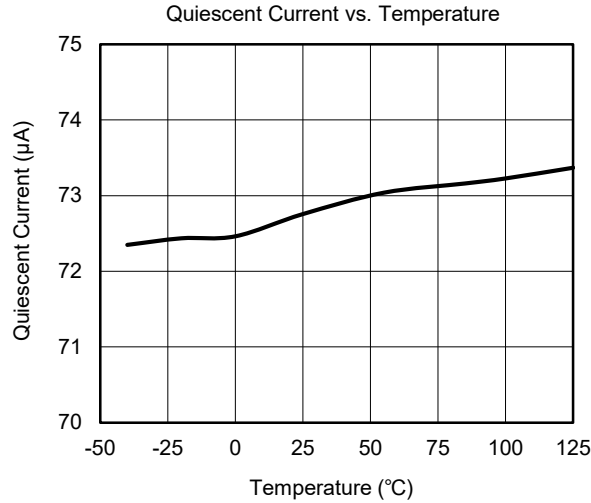
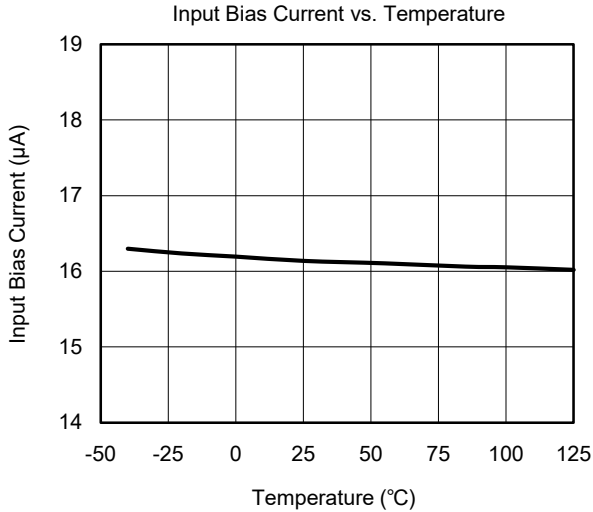

# SGM8199 Voltage Output, High-side or Low-side Measurement, Bi-Directional Current Shunt Monitor

## TYPICAL PERFORMANCE CHARACTERISTICS (continued)

Performance measured with the SGM8199A1 at  $T_A = +25^\circ\text{C}$ ,  $V_{CC} = 5\text{V}$ ,  $\text{GND} = 0\text{V}$ ,  $V_{IN+} = 12\text{V}$ ,  $V_{SENSE} = V_{IN+} - V_{IN-}$  and  $V_{REF} = V_{CC}/2$ , unless otherwise noted.

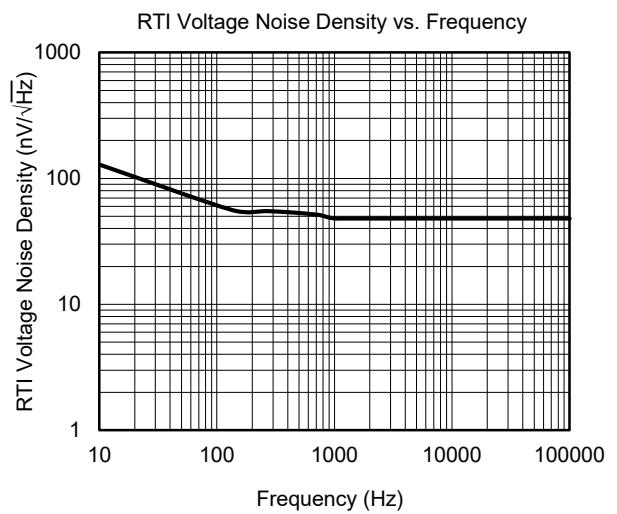
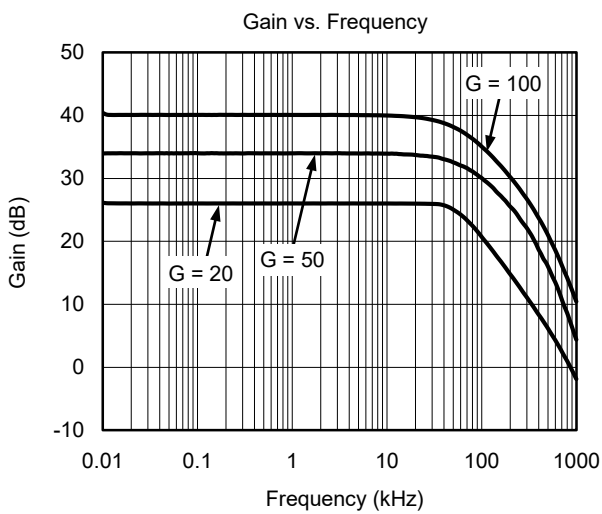
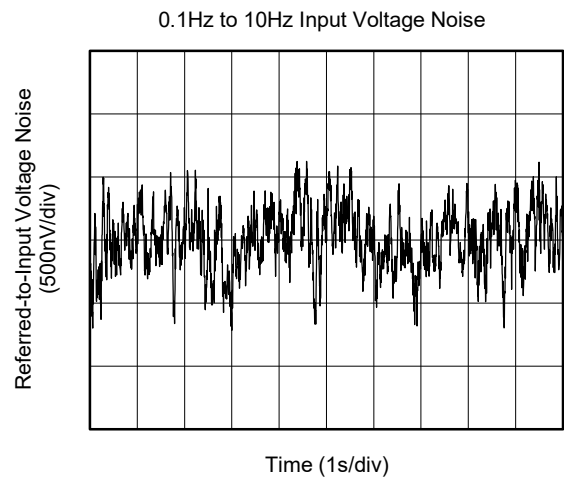
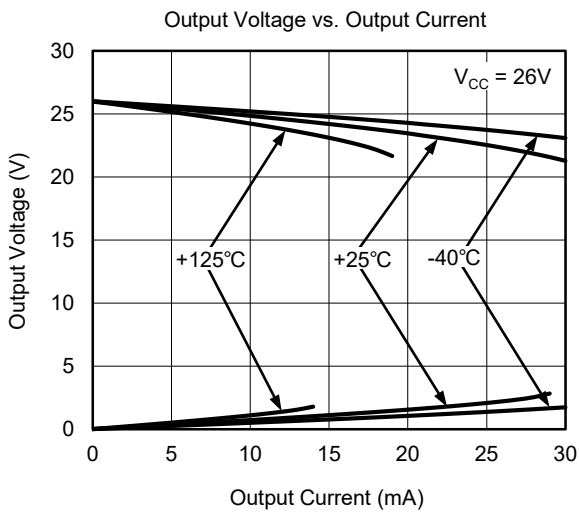
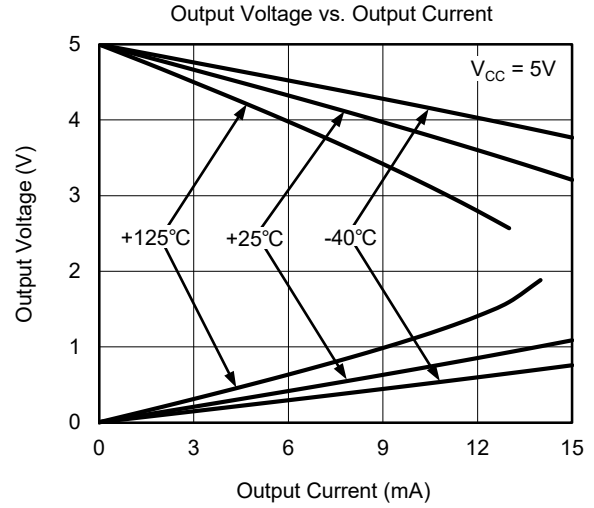
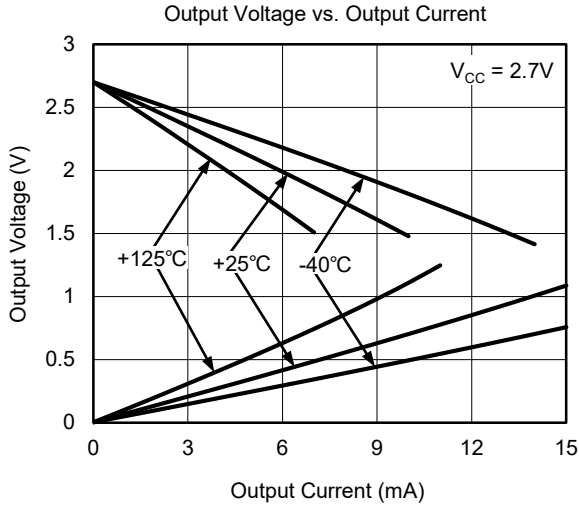

# SGM8199 Voltage Output, High-side or Low-side Measurement, Bi-Directional Current Shunt Monitor

## TYPICAL PERFORMANCE CHARACTERISTICS (continued)

Performance measured with the SGM8199A1 at  $T_A = +25^\circ\text{C}$ ,  $V_{CC} = 5\text{V}$ ,  $\text{GND} = 0\text{V}$ ,  $V_{IN+} = 12\text{V}$ ,  $V_{SENSE} = V_{IN+} - V_{IN-}$  and  $V_{REF} = V_{CC}/2$ , unless otherwise noted.

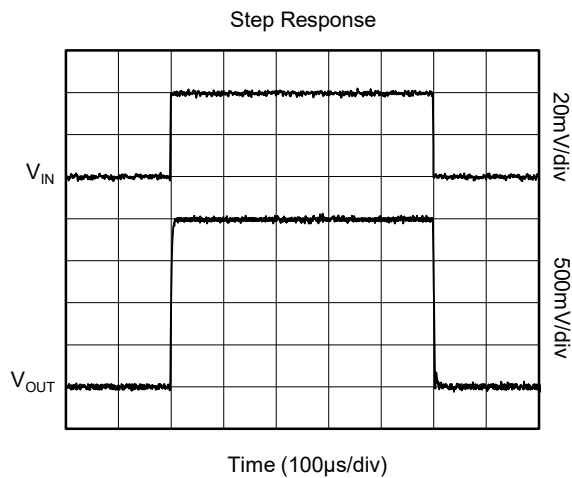
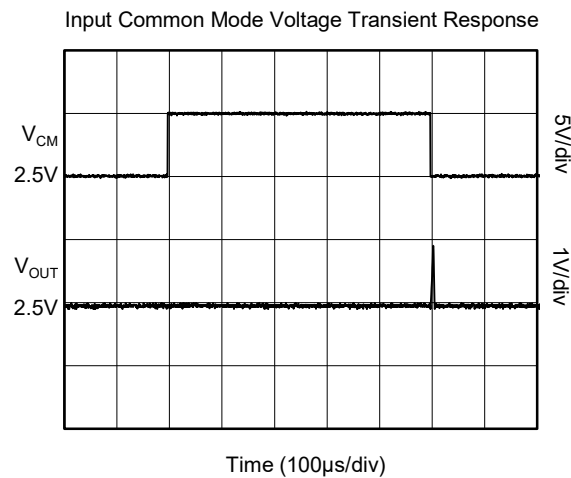
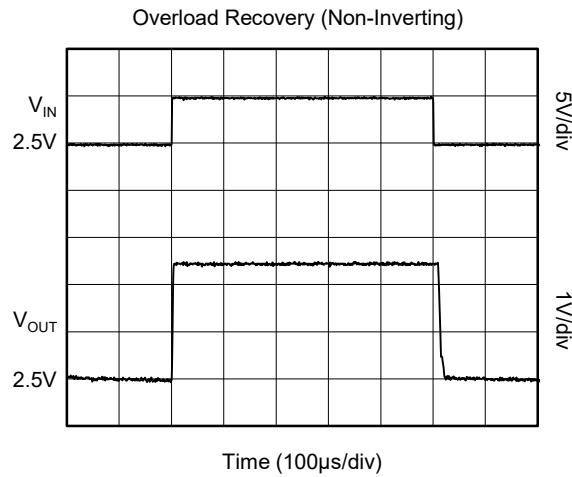
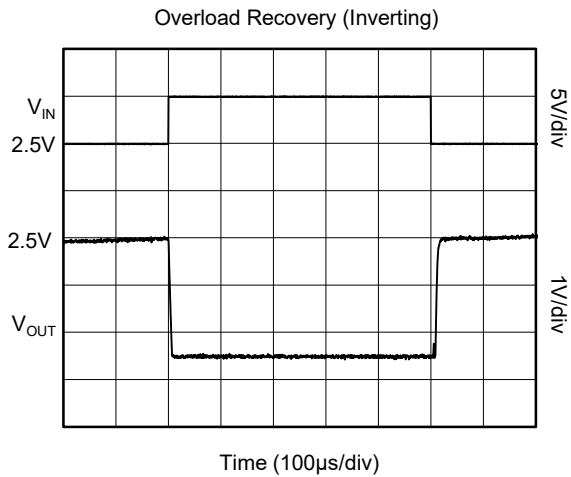
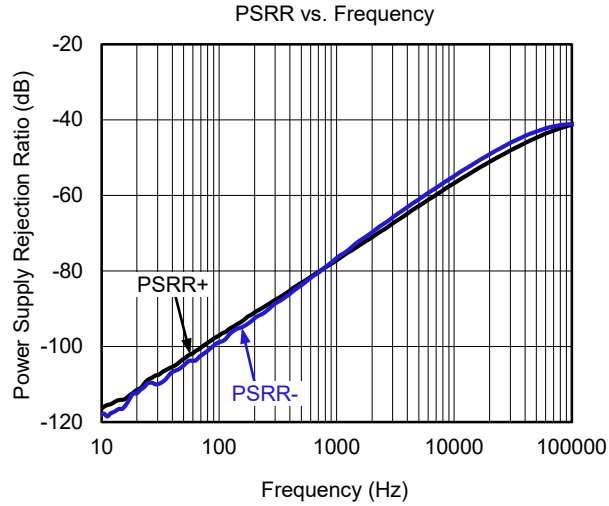
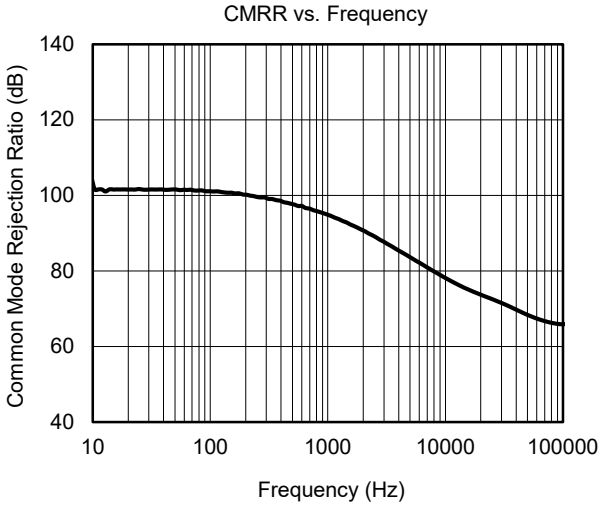

# SGM8199 Voltage Output, High-side or Low-side Measurement, Bi-Directional Current Shunt Monitor

## TYPICAL PERFORMANCE CHARACTERISTICS (continued)

Performance measured with the SGM8199A1 at  $T_A = +25^\circ\text{C}$ ,  $V_{CC} = 5\text{V}$ ,  $\text{GND} = 0\text{V}$ ,  $V_{IN+} = 12\text{V}$ ,  $V_{SENSE} = V_{IN+} - V_{IN-}$  and  $V_{REF} = V_{CC}/2$ , unless otherwise noted.

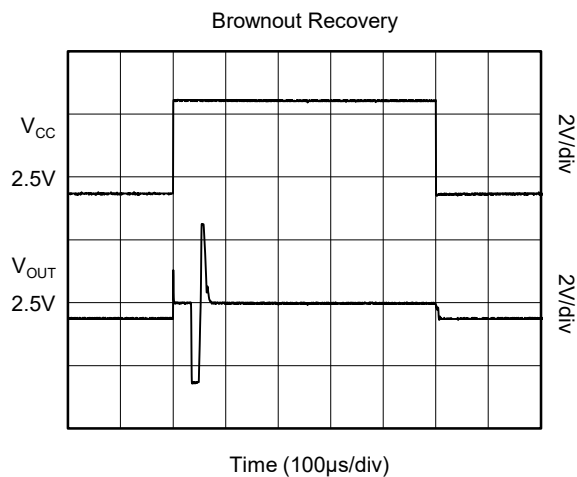
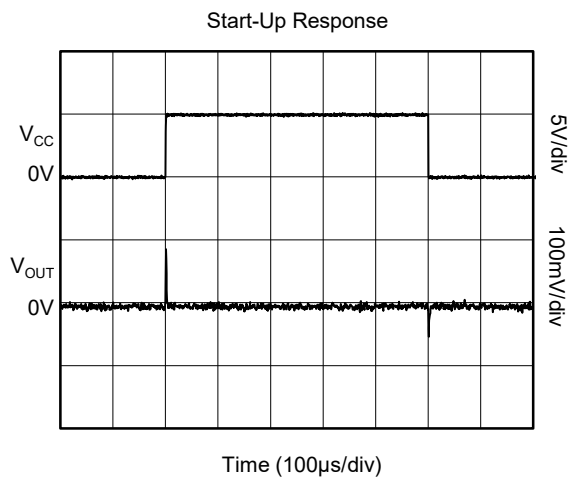



# SGM8199 Voltage Output, High-side or Low-side Measurement, Bi-Directional Current Shunt Monitor

---

## REVISION HISTORY

NOTE: Page numbers for previous revisions may differ from page numbers in the current version.

OCTOBER 2020 – REV.A to REV.A.1	Page
Updated Typical Performance Characteristics section .....	7, 8

---

Changes from Original (SEPTEMBER 2018) to REV.A	Page
Changed from product preview to production data.....	All

---

PACKAGE OUTLINE DIMENSIONS

SC70-6

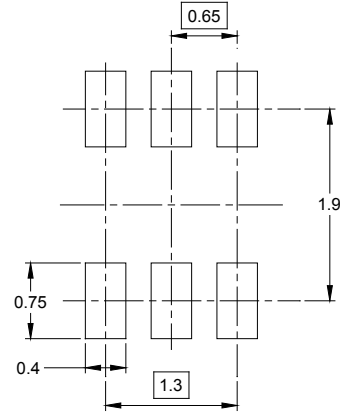
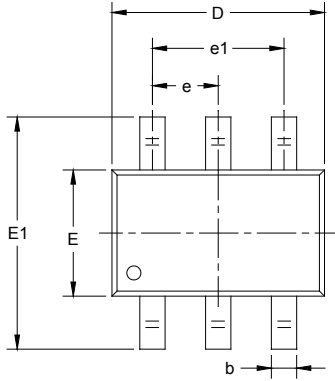

RECOMMENDED LAND PATTERN (Unit: mm)

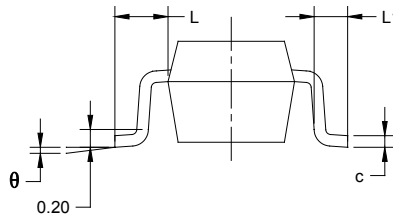
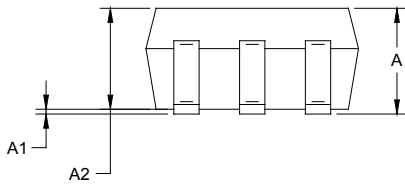

Symbol	Dimensions In Millimeters		Dimensions In Inches	
	MIN	MAX	MIN	MAX
A	0.900	1.100	0.035	0.043
A1	0.000	0.100	0.000	0.004
A2	0.900	1.000	0.035	0.039
b	0.150	0.350	0.006	0.014
c	0.080	0.150	0.003	0.006
D	2.000	2.200	0.079	0.087
E	1.150	1.350	0.045	0.053
E1	2.150	2.450	0.085	0.096
e	0.65 TYP		0.026 TYP	
e1	1.300 BSC		0.051 BSC	
L	0.525 REF		0.021 REF	
L1	0.260	0.460	0.010	0.018
$\theta$	0°	8°	0°	8°

# PACKAGE INFORMATION

## TAPE AND REEL INFORMATION

### REEL DIMENSIONS

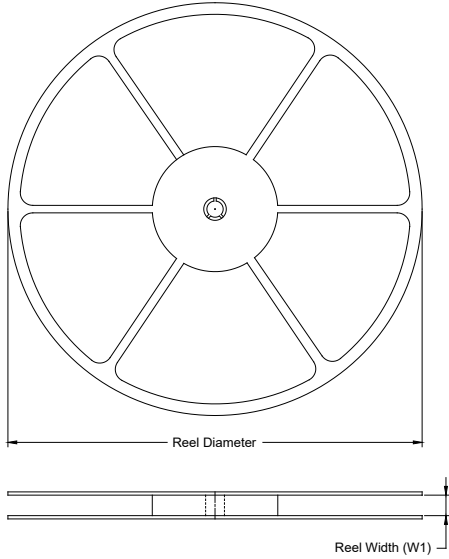

### TAPE DIMENSIONS

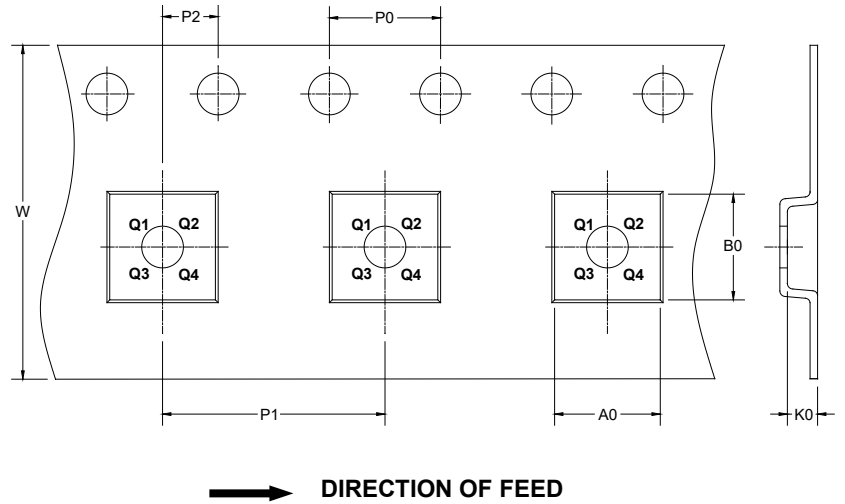

NOTE: The picture is only for reference. Please make the object as the standard.

### KEY PARAMETER LIST OF TAPE AND REEL

Package Type	Reel Diameter	Reel Width W1 (mm)	A0 (mm)	B0 (mm)	K0 (mm)	P0 (mm)	P1 (mm)	P2 (mm)	W (mm)	Pin1 Quadrant
SC70-6	7"	9.5	2.40	2.50	1.20	4.0	4.0	2.0	8.0	Q3

000001

# PACKAGE INFORMATION

## CARTON BOX DIMENSIONS

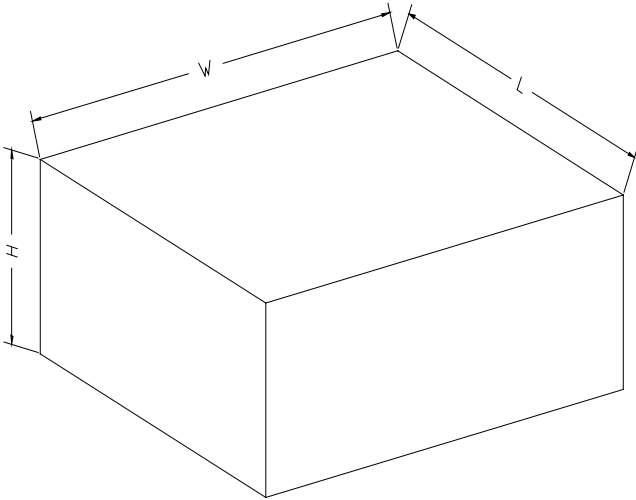

NOTE: The picture is only for reference. Please make the object as the standard.

## KEY PARAMETER LIST OF CARTON BOX

Reel Type	Length (mm)	Width (mm)	Height (mm)	Pizza/Carton
7" (Option)	368	227	224	8
7"	442	410	224	18

DD0002

单击下面可查看定价，库存，交付和生命周期等信息

[>>SGMICRO\(圣邦微电子\)](#)