



SGM8608-2

11MHz, Rail-to-Rail I/O CMOS Operational Amplifier

GENERAL DESCRIPTION

The SGM8608-2 is a low noise, low power operational amplifier optimized for low voltage operation. The device can operate from 2.1V to 5.5V single supply, and consumes only 1.1mA quiescent current per amplifier at 5V.

The SGM8608-2 features a 1.7mV maximum input offset voltage. The minimum input common mode voltage is within 0.1V below the negative rail, and the output swing is rail-to-rail with heavy loads. It exhibits a high gain-bandwidth product of 11MHz and a slew rate of 6.6V/ μ s. These specifications make the operational amplifier appropriate for a wide range of applications.

The SGM8608-2 is available in Green SOIC-8, MSOP-8, TSSOP-8 and UTDFN-2 \times 2-8BL packages. It is specified over the extended industrial temperature range (-40°C to +125°C).

FEATURES

- **Input Offset Voltage: 1.7mV (MAX)**
- **High Gain-Bandwidth Product: 11MHz**
- **High Slew Rate: 6.6V/ μ s**
- **Settling Time to 0.1% with 2V Step: 500ns**
- **Overload Recovery Time: 0.16 μ s**
- **Low Noise: 12nV/ $\sqrt{\text{Hz}}$ at 10kHz**
- **Rail-to-Rail Input and Output**
- **Supply Voltage Range: 2.1V to 5.5V**
- **Input Voltage Range: -0.1V to 5.6V with $V_S = 5.5V$**
- **Low Power: 1.1mA/Amplifier (TYP)**
- **-40°C to +125°C Operating Temperature Range**
- **Available in Green SOIC-8, MSOP-8, TSSOP-8 and UTDFN-2 \times 2-8BL Packages**

APPLICATIONS

Sensors
Audio
Active Filters
A/D Converters
Communications
Test Equipment
Cellular and Cordless Phones
Laptops and PDAs
Photodiode Amplification
Battery-Powered Instrumentation

PACKAGE/ORDERING INFORMATION

MODEL	PACKAGE DESCRIPTION	SPECIFIED TEMPERATURE RANGE	ORDERING NUMBER	PACKAGE MARKING	PACKING OPTION
SGM8608-2	SOIC-8	-40°C to +125°C	SGM8608-2XS8G/TR	SGM 86082XS8 XXXXX	Tape and Reel, 4000
	MSOP-8	-40°C to +125°C	SGM8608-2XMS8G/TR	SGMG3K XMS8 XXXXX	Tape and Reel, 4000
	TSSOP-8	-40°C to +125°C	SGM8608-2XTS8G/TR	SGMG3J XTS8 XXXXX	Tape and Reel, 4000
	UTDFN-2x2-8BL	-40°C to +125°C	SGM8608-2XUGD8G/TR	MDP XXXX	Tape and Reel, 3000

MARKING INFORMATION

NOTE: XXXX = Date Code, Trace Code and Vendor Code.

SOIC-8/MSOP-8/TSSOP-8

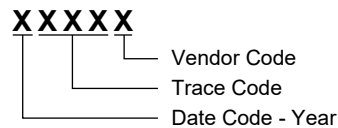

UTDFN-2x2-8BL

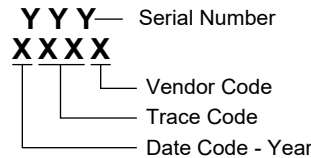

Green (RoHS & HSF): SG Micro Corp defines "Green" to mean Pb-Free (RoHS compatible) and free of halogen substances. If you have additional comments or questions, please contact your SGMICRO representative directly.

ABSOLUTE MAXIMUM RATINGS

- Supply Voltage, +Vs to -Vs6V
- Input Common Mode Voltage Range (-Vs) - 0.3V to (+Vs) + 0.3V
- Junction Temperature+150°C
- Storage Temperature Range-65°C to +150°C
- Lead Temperature (Soldering, 10s).....+260°C
- ESD Susceptibility
- HBM..... 8000V
- CDM 1000V

RECOMMENDED OPERATING CONDITIONS

- Operating Temperature Range-40°C to +125°C

OVERSTRESS CAUTION

Stresses beyond those listed in Absolute Maximum Ratings may cause permanent damage to the device. Exposure to absolute maximum rating conditions for extended periods may affect reliability. Functional operation of the device at any conditions beyond those indicated in the Recommended Operating Conditions section is not implied.

ESD SENSITIVITY CAUTION

This integrated circuit can be damaged if ESD protections are not considered carefully. SGMICRO recommends that all integrated circuits be handled with appropriate precautions. Failure to observe proper handling and installation procedures can cause damage. ESD damage can range from subtle performance degradation to complete device failure. Precision integrated circuits may be more susceptible to damage because even small parametric changes could cause the device not to meet the published specifications.

DISCLAIMER

SG Micro Corp reserves the right to make any change in circuit design, or specifications without prior notice.

PIN CONFIGURATIONS

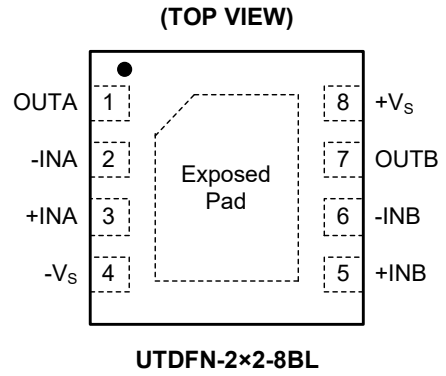
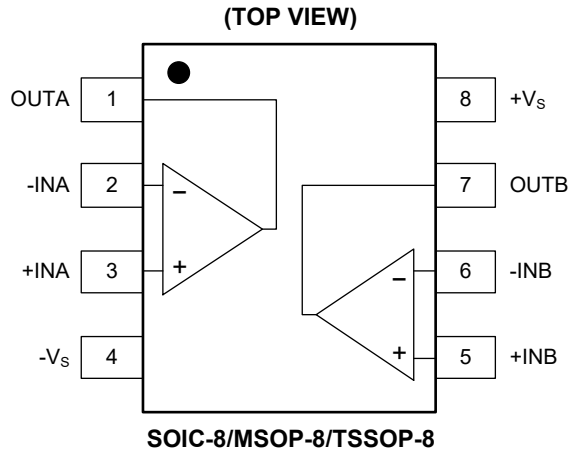

NOTE: For the UTDFN-2x2-8BL package, the exposed pad is not internally connected and can be set to ground or left floating.

ELECTRICAL CHARACTERISTICS

(For V_S (Total Supply Voltage) = $(+V_S) - (-V_S) = 2.1V$ to $5.5V$, $V_{CM} = V_S/2$, $V_{OUT} = V_S/2$, and $R_L = 600\Omega$ connected to $V_S/2$, Full = $-40^\circ C$ to $+125^\circ C$, typical values are at $T_A = +25^\circ C$, unless otherwise noted.)

PARAMETER	SYMBOL	CONDITIONS	TEMP	MIN	TYP	MAX	UNITS
Input Characteristics							
Input Offset Voltage	V_{OS}	$V_S = 5V$	+25°C		±0.4	±1.7	mV
			Full			±1.9	
Input Offset Voltage Drift	$\Delta V_{OS}/\Delta T$	$V_S = 5V$	Full		0.9		$\mu V/^\circ C$
Input Bias Current	I_B		+25°C		10	150	pA
			Full			5000	
Input Offset Current	I_{OS}		+25°C		10	150	pA
			Full			1500	
Input Common Mode Voltage Range	V_{CM}		Full	$(-V_S) - 0.1$		$(+V_S) + 0.1$	V
Common Mode Rejection Ratio	CMRR	$V_S = 2.1V$, $(-V_S) - 0.1V < V_{CM} < (+V_S) - 1.7V$	+25°C	74	91		dB
			Full	71			
		$V_S = 2.1V$, $(-V_S) - 0.1V < V_{CM} < (+V_S) + 0.1V$	+25°C	60	74		
			Full	57			
		$V_S = 5.5V$, $(-V_S) - 0.1V < V_{CM} < (+V_S) - 1.7V$	+25°C	80	96		
			Full	77			
		$V_S = 5.5V$, $(-V_S) - 0.1V < V_{CM} < (+V_S) + 0.1V$	+25°C	68	82		
			Full	65			
Input Common Mode Capacitance	C_{IC}		+25°C		26		pF
Input Differential Capacitance	C_{ID}		+25°C		2		pF
Open-Loop Voltage Gain	A_{OL}	$V_S = 2.1V$, $R_L = 600\Omega$, $(-V_S) + 0.4V < V_{OUT} < (+V_S) - 0.4V$	+25°C	89	112		dB
			Full	86			
		$V_S = 2.1V$, $R_L = 10k\Omega$, $(-V_S) + 0.2V < V_{OUT} < (+V_S) - 0.2V$	+25°C	90	115		
			Full	87			
		$V_S = 5.5V$, $R_L = 600\Omega$, $(-V_S) + 0.4V < V_{OUT} < (+V_S) - 0.4V$	+25°C	95	120		
			Full	86			
		$V_S = 5.5V$, $R_L = 10k\Omega$, $(-V_S) + 0.2V < V_{OUT} < (+V_S) - 0.2V$	+25°C	98	140		
			Full	86			
Output Characteristics							
Output Voltage Swing from Rail	V_{OUT}	$V_S = 5.5V$, $R_L = 10k\Omega$	+25°C		4	10	mV
			Full			20	
		$V_S = 5.5V$, $R_L = 600\Omega$	+25°C		55	75	
			Full			90	
Output Short-Circuit Current	I_{SC}	$V_S = 5V$	+25°C	50	62		mA
			Full	35			
Open-Loop Output Impedance	Z_{OUT}	$V_S = 5V$, $f = 10MHz$	+25°C		95		Ω

ELECTRICAL CHARACTERISTICS (continued)

(For V_S (Total Supply Voltage) = $(+V_S) - (-V_S) = 2.1V$ to $5.5V$, $V_{CM} = V_S/2$, $V_{OUT} = V_S/2$, and $R_L = 600\Omega$ connected to $V_S/2$, Full = $-40^\circ C$ to $+125^\circ C$, typical values are at $T_A = +25^\circ C$, unless otherwise noted.)

PARAMETER	SYMBOL	CONDITIONS	TEMP	MIN	TYP	MAX	UNITS
Power Supply							
Operating Voltage Range	V_S		Full	2.1		5.5	V
Power Supply Rejection Ratio	PSRR	$V_{CM} = (-V_S) + 0.4V$	+25°C		2	25	$\mu V/V$
			Full			28	
Quiescent Current/Amplifier	I_Q	$V_S = 5V$	+25°C		1.1	1.45	mA
			Full			1.8	
Dynamic Performance							
Gain-Bandwidth Product	GBP	$V_S = 5V$, $G = +1$, $R_L = 600\Omega$, $C_L = 100pF$	+25°C		11		MHz
Phase Margin	PM	$V_S = 5V$, $G = +1$, $R_L = 600\Omega$, $C_L = 100pF$	+25°C		45		°
Slew Rate	SR	$V_S = 5V$, $G = +1$, $R_L = 600\Omega$, $V_{OUT} = 2V_{P,P}$, $V_{CM} = 1/2V_S$ (10%~90%)	+25°C		6.6		V/ μs
Settling Time to 0.1%	t_s	$V_S = 5V$, $G = +1$, 2V step, $R_L = 600\Omega$, $C_L = 100pF$	+25°C		500		ns
Overload Recovery Time	ORT	$V_S = 5V$, $V_{IN} \times G > V_S$, $R_L = 600\Omega$	+25°C		0.16		μs
Total Harmonic Distortion + Noise	THD+N	$V_S = 5.5V$, $V_{CM} = 2.5V$, $V_{OUT} = 0.5V_{RMS}$, $G = +1$, $f = 1kHz$, $BW = 10Hz$ to $90kHz$	+25°C		0.0008		%
Full-Power Bandwidth	BWP	< 1% distortion	+25°C		120		kHz
Noise							
Input Voltage Noise		$f = 0.1Hz$ to $10Hz$	+25°C		8		$\mu V_{P,P}$
Input Voltage Noise Density	e_n	$f = 1kHz$	+25°C		30		nV/\sqrt{Hz}
		$f = 10kHz$	+25°C		12		
Input Current Noise Density	i_n	$f = 1kHz$	+25°C		31		fA/\sqrt{Hz}

TYPICAL PERFORMANCE CHARACTERISTICS

At $T_A = +25^\circ\text{C}$, $V_S = 5.5\text{V}$, unless otherwise noted.

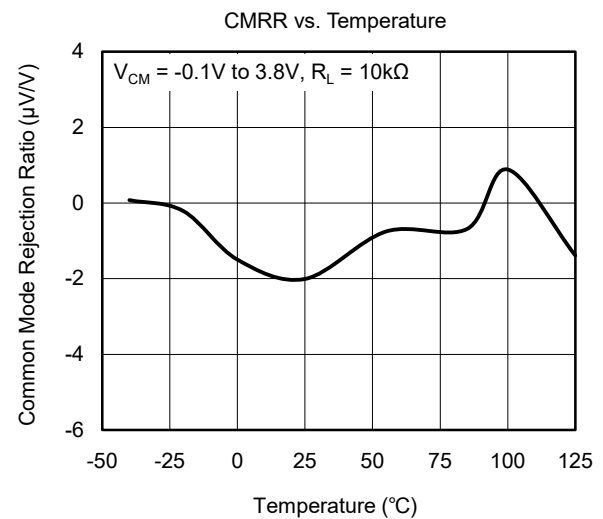
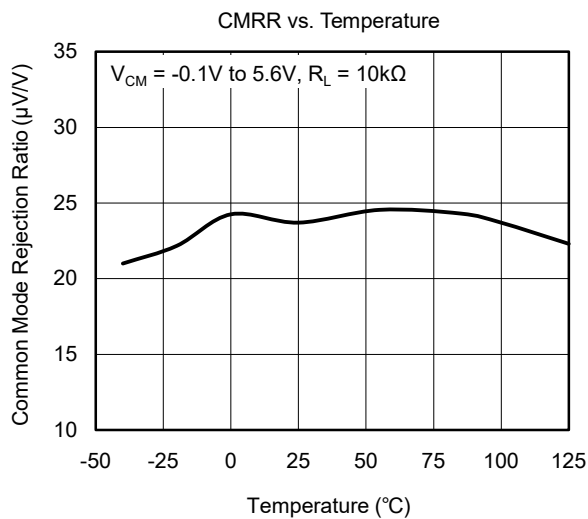
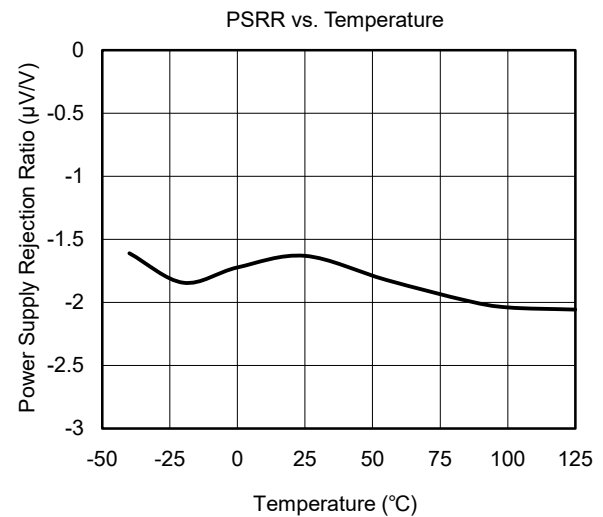
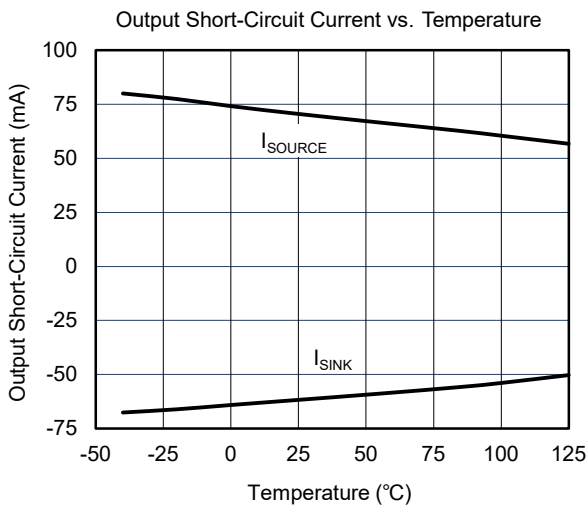
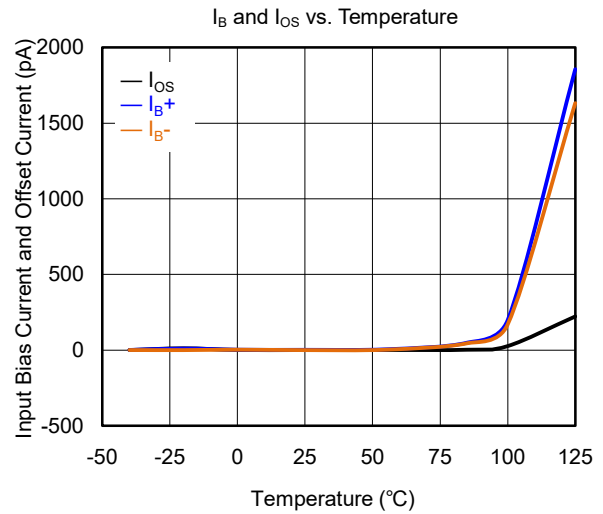
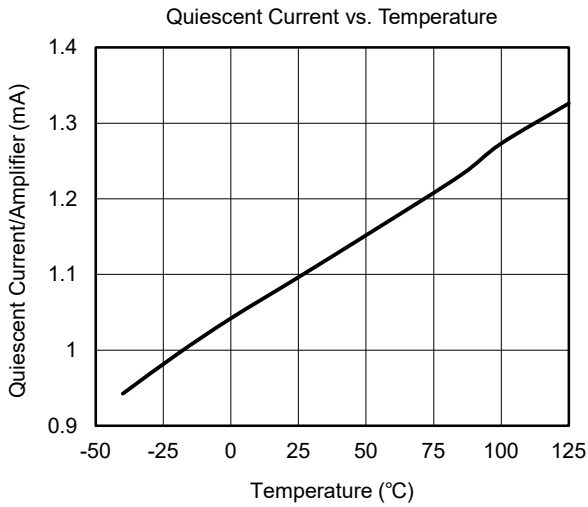

TYPICAL PERFORMANCE CHARACTERISTICS (continued)

At $T_A = +25^\circ\text{C}$, $V_S = 5.5\text{V}$, unless otherwise noted.

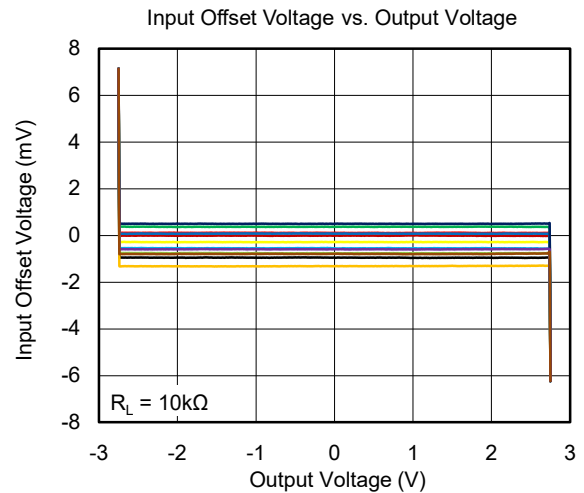
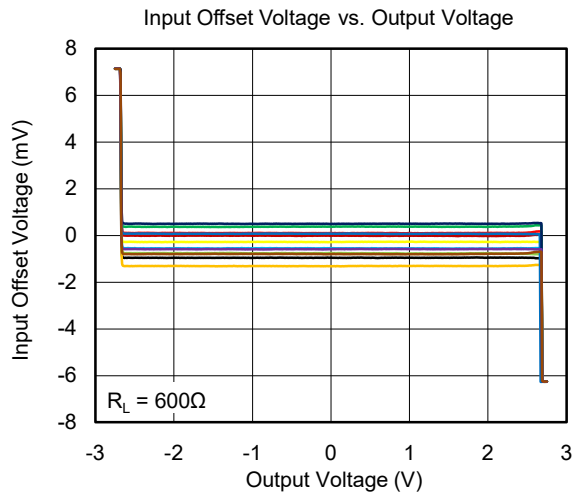
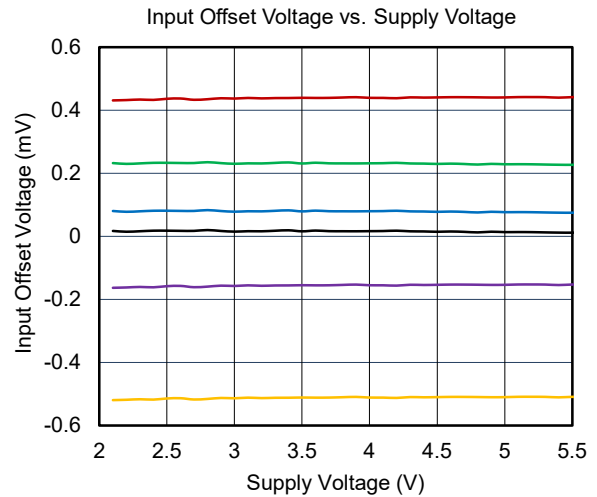
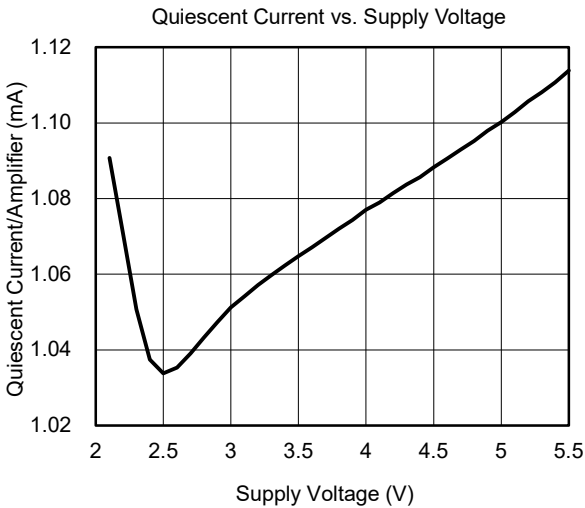
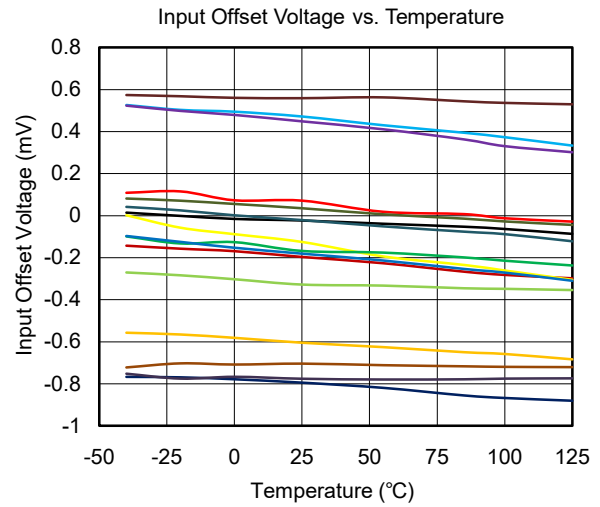
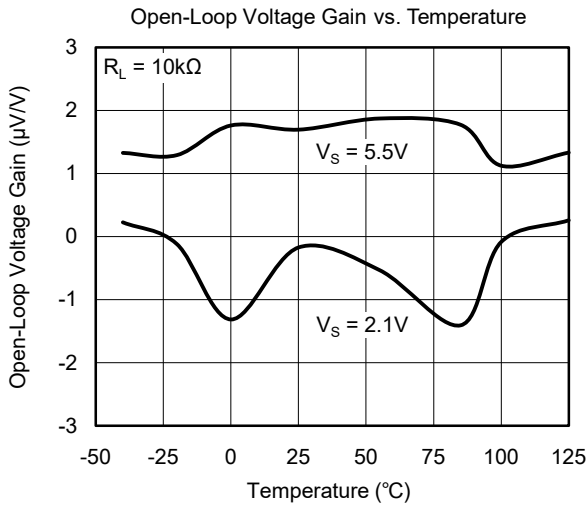

TYPICAL PERFORMANCE CHARACTERISTICS (continued)

At $T_A = +25^\circ\text{C}$, $V_S = 5.5\text{V}$, unless otherwise noted.

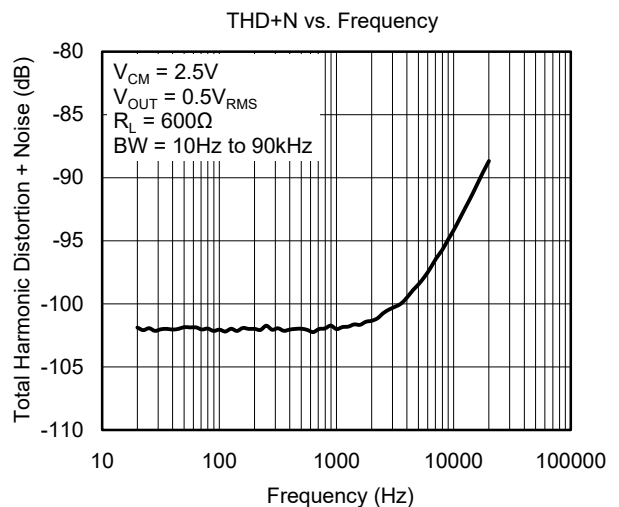
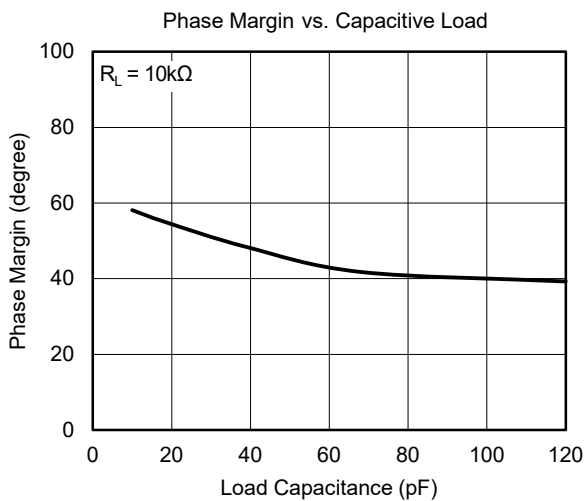
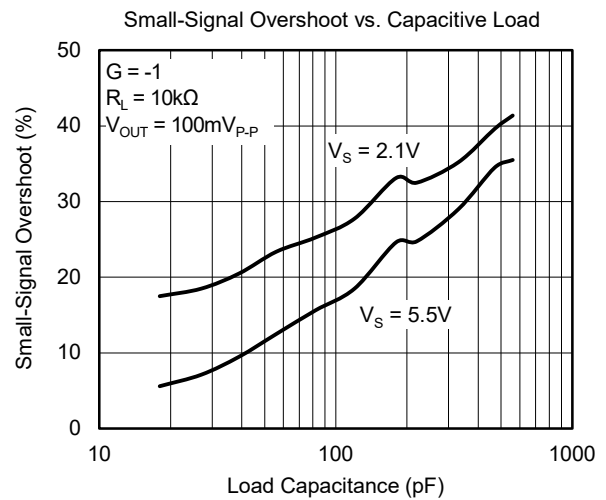
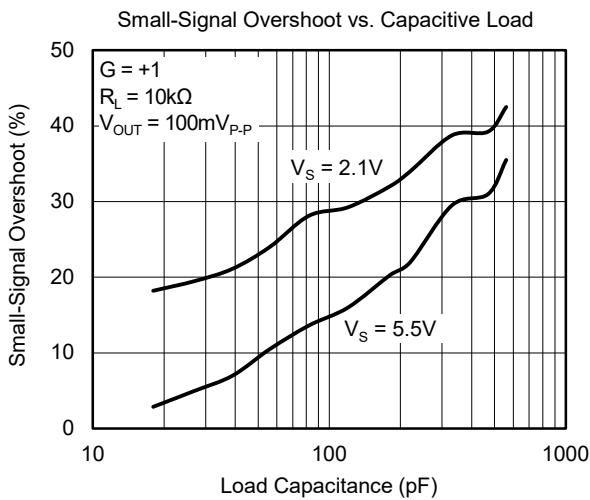
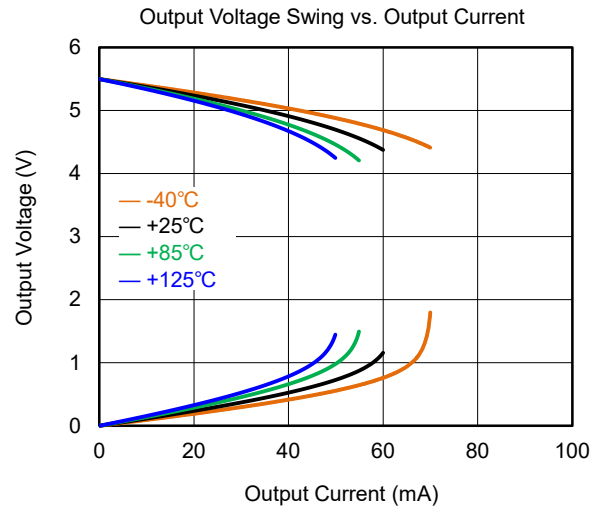
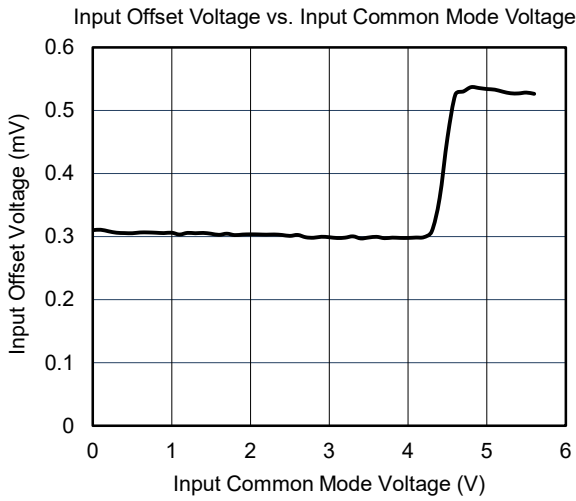

TYPICAL PERFORMANCE CHARACTERISTICS (continued)

At $T_A = +25^\circ\text{C}$, $V_S = 5.5\text{V}$, unless otherwise noted.

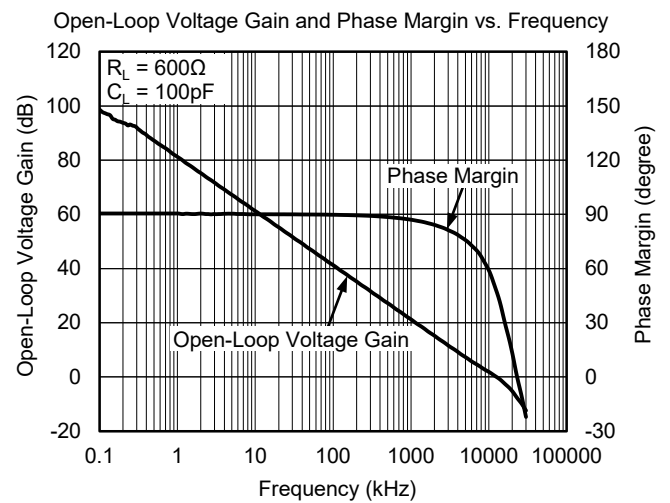
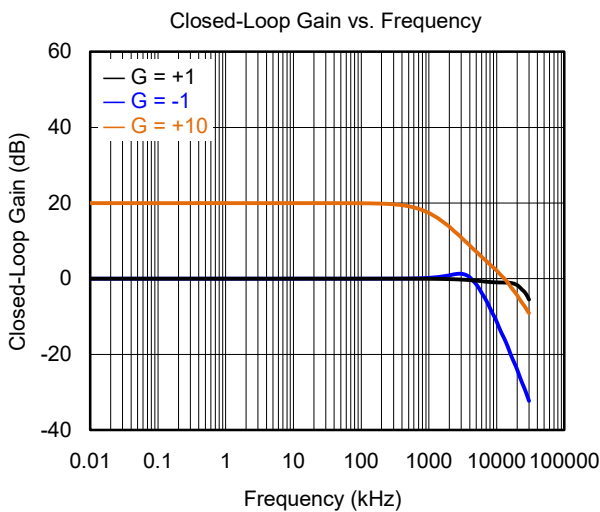
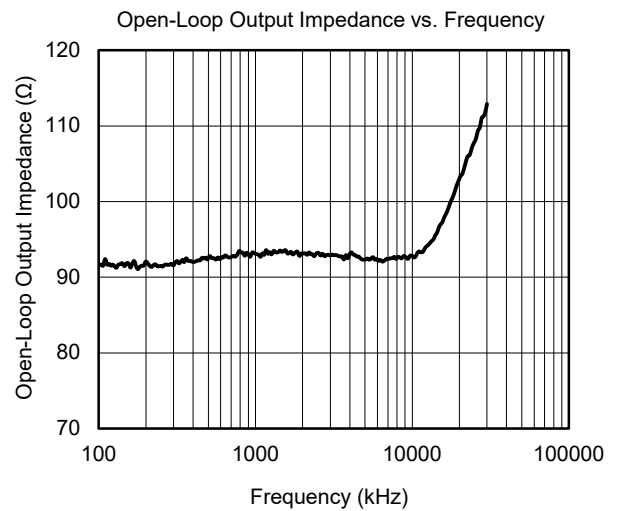
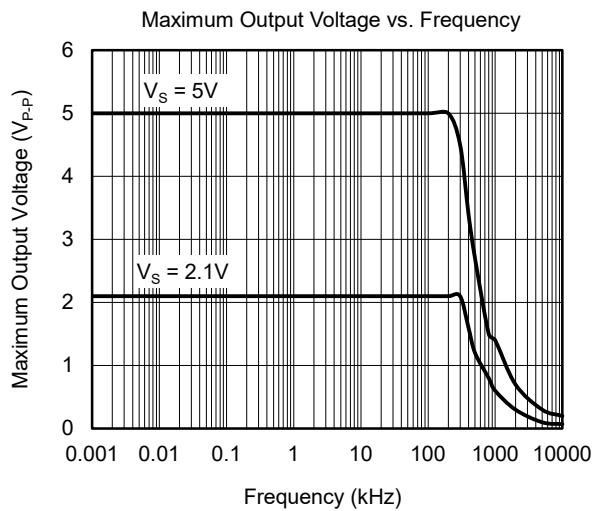
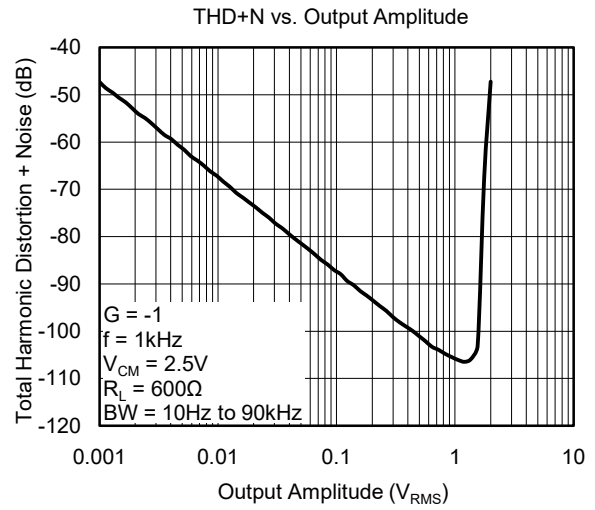
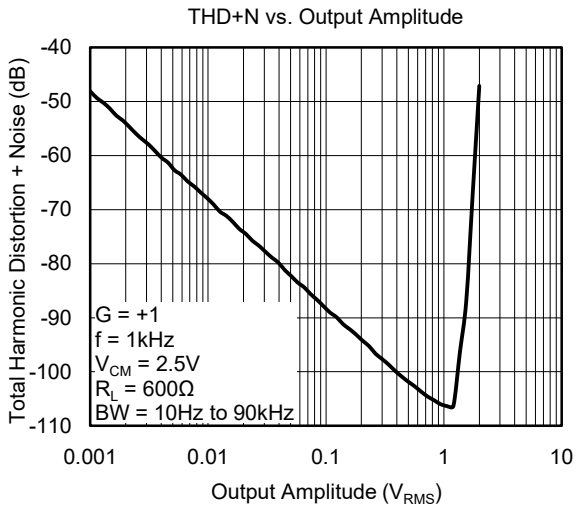

TYPICAL PERFORMANCE CHARACTERISTICS (continued)

At $T_A = +25^\circ\text{C}$, $V_S = 5.5\text{V}$, unless otherwise noted.

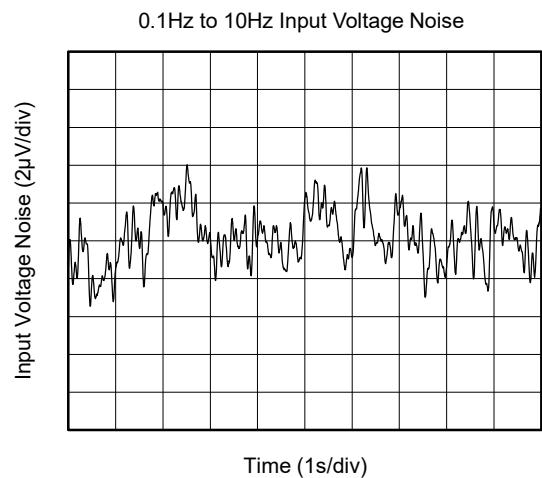
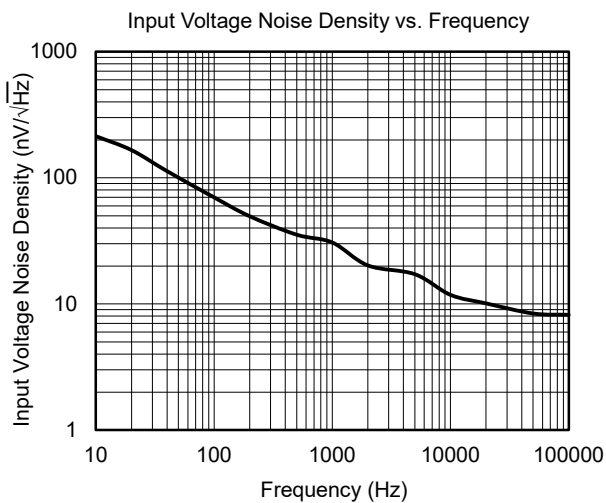
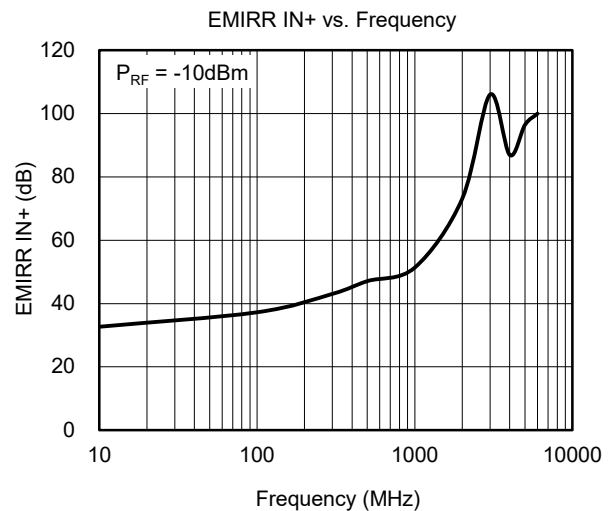
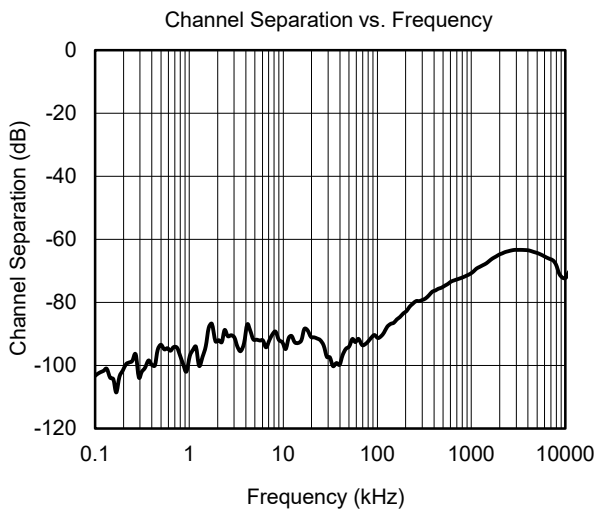
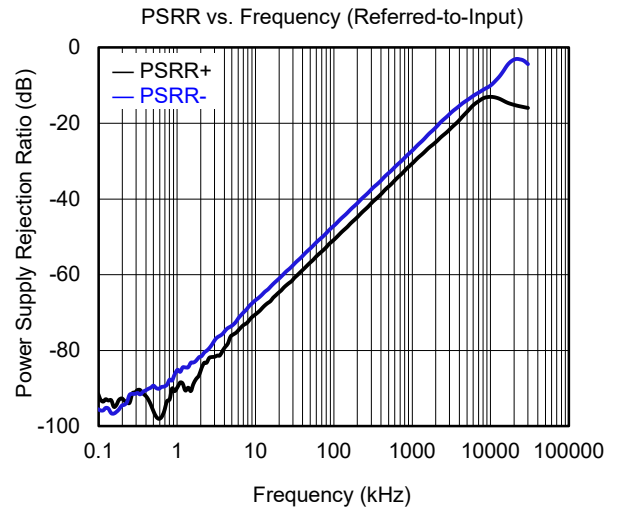
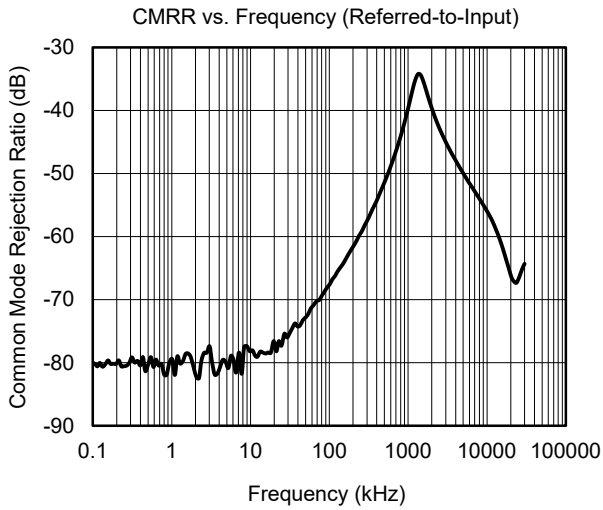

TYPICAL PERFORMANCE CHARACTERISTICS (continued)

At $T_A = +25^\circ\text{C}$, $V_S = 5.5\text{V}$, unless otherwise noted.

Positive Overload Recovery

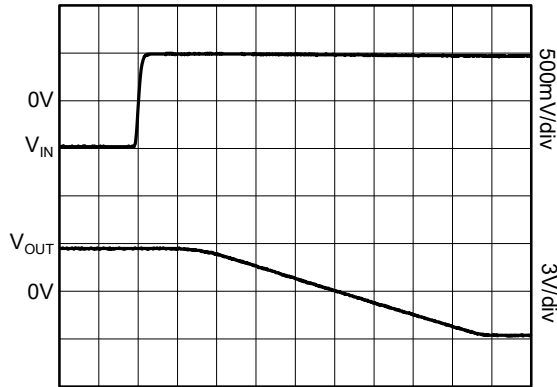

Time (100ns/div)

Negative Overload Recovery

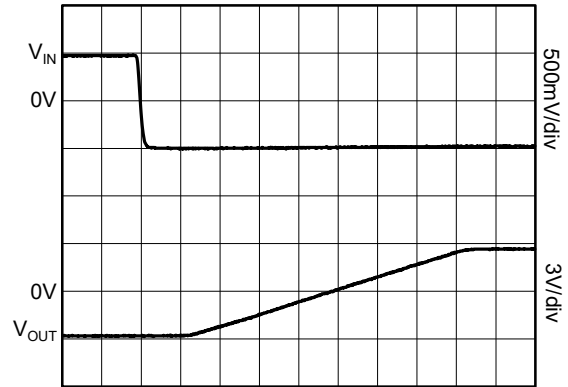

Time (100ns/div)

Small-Signal Step Response

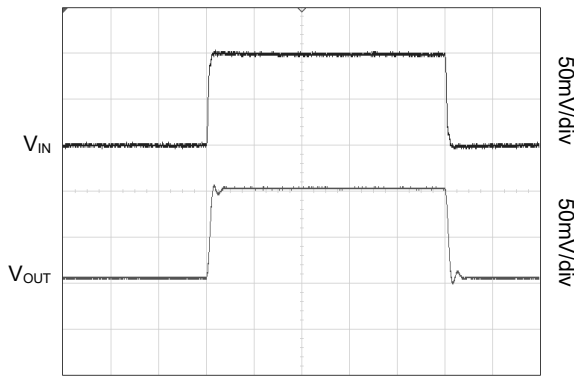

Time (200ns/div)

Large-Signal Step Response

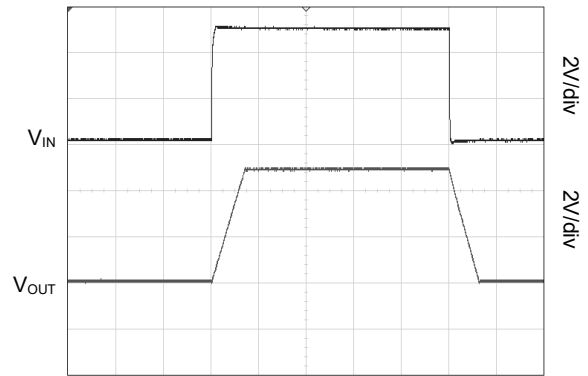

Time (1μs/div)

No Phase Reversal

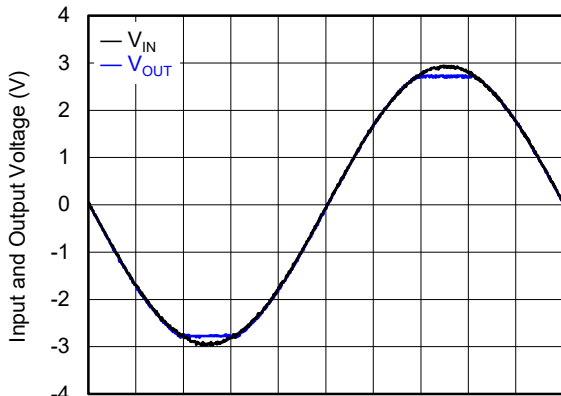

Time (100μs/div)

Input Offset Voltage Production Distribution

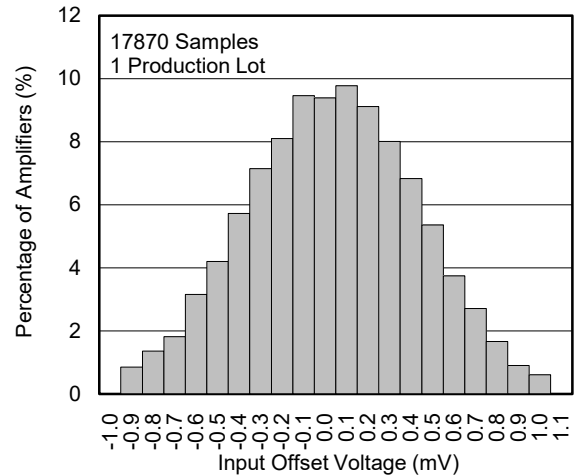

TYPICAL PERFORMANCE CHARACTERISTICS (continued)

At $T_A = +25^\circ\text{C}$, $V_S = 5.5\text{V}$, unless otherwise noted.

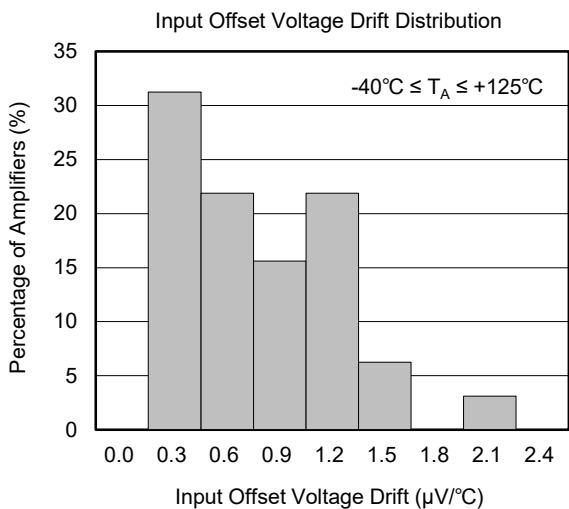

APPLICATION INFORMATION

Rail-to-Rail Output

The SGM8608-2 supports rail-to-rail output operation. In single power supply application, for example, when $+V_S = 5.5V$, $-V_S = GND$, $10k\Omega$ load resistor is tied from OUT pin to $V_S/2$, the typical output swing range is from $0.004V$ to $5.496V$.

Driving Capacitive Loads

The SGM8608-2 is designed for unity-gain stable for capacitive load up to $2200pF$. If greater capacitive load must be driven in application, the circuit in Figure 1 can be used. In this circuit, the IR drop voltage generated by R_{ISO} is compensated by feedback loop.

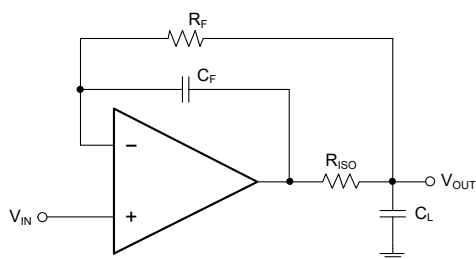

Figure 1. Circuit to Drive Heavy Capacitive Load

Power Supply Decoupling and Layout

A clean and low noise power supply is very important in amplifier circuit design, besides of input signal noise, the power supply is one of important source of noise to the amplifier through $+V_S$ and $-V_S$ pins. Power supply bypassing is an effective method to clear up the noise at power supply, and the low impedance path to ground of decoupling capacitor will bypass the noise to GND. In application, $10\mu F$ ceramic capacitor paralleled with $0.1\mu F$ or $0.01\mu F$ ceramic capacitor is used in Figure 2. The ceramic capacitors should be placed as close as possible to $+V_S$ and $-V_S$ power supply pins.

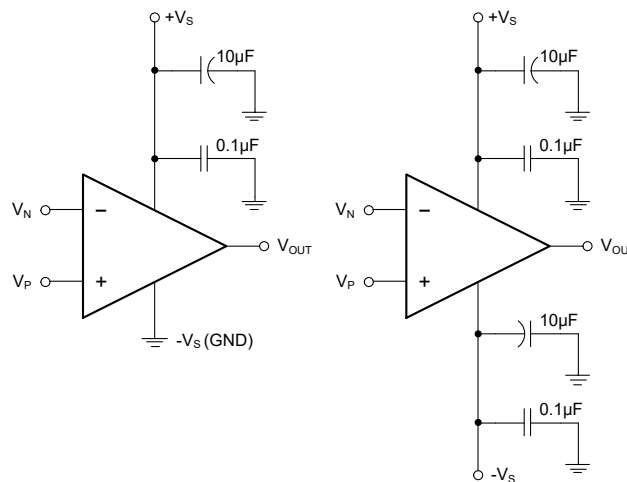

Figure 2. Amplifier Power Supply Bypassing

Grounding

In low speed application, one node grounding technique is the simplest and most effective method to eliminate the noise generated by grounding. In high speed application, the general method to eliminate noise is to use a complete ground plane technique, and the whole ground plane will help distribute heat and reduce EMI noise pickup.

Reduce Input-to-Output Coupling

To reduce the input-to-output coupling, the input traces must be placed as far away from the power supply or output traces as possible. The sensitive trace must not be placed in parallel with the noisy trace in same layer. They must be placed perpendicularly in different layers to reduce the crosstalk. These PCB layout techniques will help to reduce unwanted positive feedback and noise.

APPLICATION INFORMATION (continued)

Typical Application Circuits

Difference Amplifier

The circuit in Figure 3 is a design example of classical difference amplifier. If $R_4/R_3 = R_2/R_1$, then $V_{OUT} = (V_P - V_N) \times R_2/R_1 + V_{REF}$.

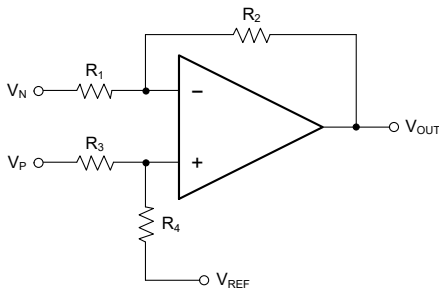

Figure 3. Difference Amplifier

High Input Impedance Difference Amplifier

The circuit in Figure 4 is a design example of high input impedance difference amplifier, the added amplifiers at the input are used to increase the input impedance and eliminate drawback of low input impedance in Figure 3.

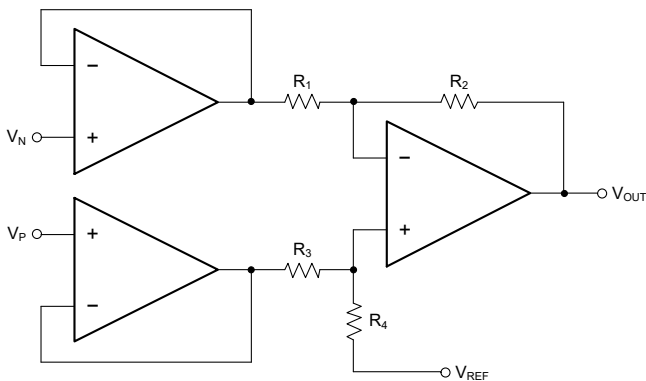

Figure 4. High Input Impedance Difference Amplifier

Active Low-Pass Filter

The circuit in Figure 5 is a design example of active low-pass filter, the DC gain is equal to $-R_2/R_1$ and the -3dB corner frequency is equal to $1/2\pi R_2 C$. In this design, the filter bandwidth must be less than the bandwidth of the amplifier, the resistor values must be selected as low as possible to reduce ringing or oscillation generated by the parasitic parameters in PCB layout.

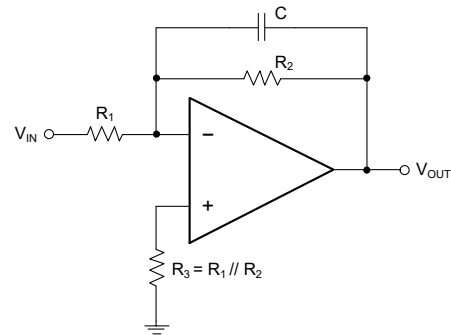

Figure 5. Active Low-Pass Filter

REVISION HISTORY

NOTE: Page numbers for previous revisions may differ from page numbers in the current version.

Changes from Original (NOVEMBER 2022) to REV.A	Page
Changed from product preview to production data.....	All

PACKAGE OUTLINE DIMENSIONS

UTDFN-2x2-8BL

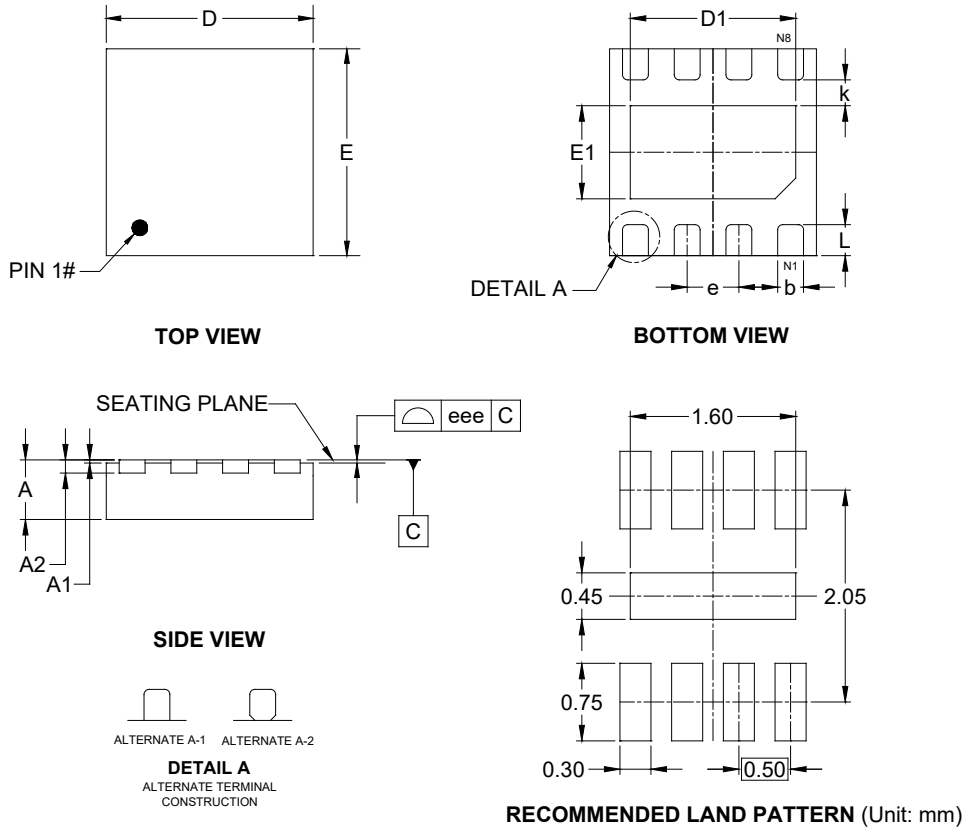

Symbol	Dimensions In Millimeters		
	MIN	MOD	MAX
A	0.500	-	0.600
A1	0.000	-	0.050
A2	0.127 REF		
b	0.200	-	0.300
D	1.900	-	2.100
E	1.900	-	2.100
D1	1.500	1.600	1.700
E1	0.800	0.900	1.000
e	0.500 BSC		
k	0.250 REF		
L	0.200	-	0.400
eee	0.050		

NOTE: This drawing is subject to change without notice.

PACKAGE OUTLINE DIMENSIONS

SOIC-8

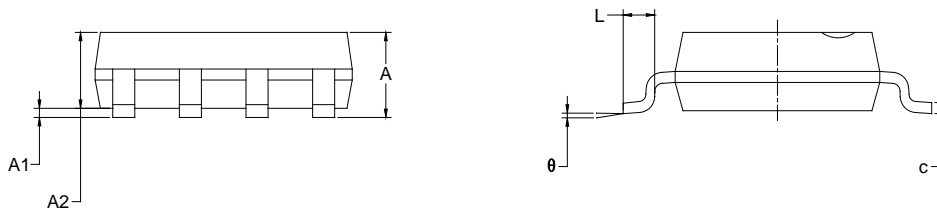
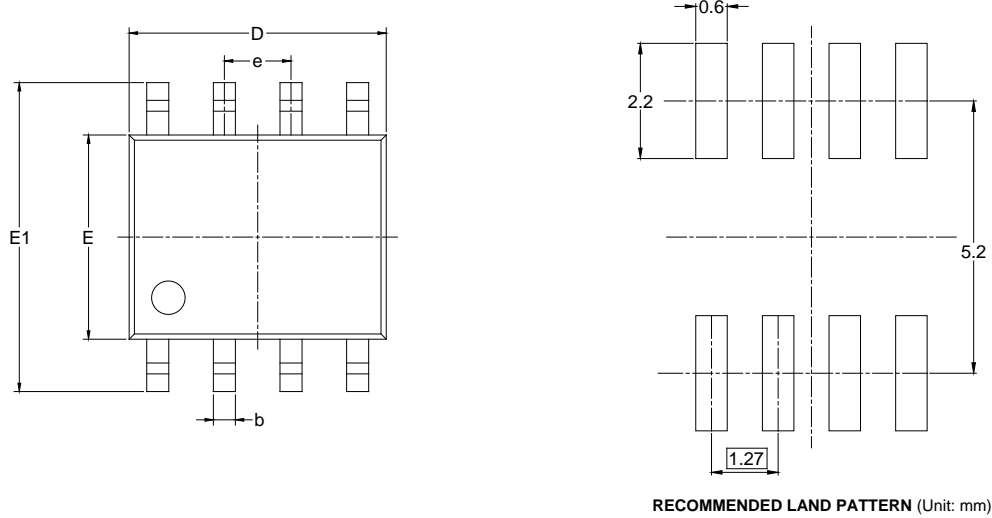

Symbol	Dimensions In Millimeters		Dimensions In Inches	
	MIN	MAX	MIN	MAX
A	1.350	1.750	0.053	0.069
A1	0.100	0.250	0.004	0.010
A2	1.350	1.550	0.053	0.061
b	0.330	0.510	0.013	0.020
c	0.170	0.250	0.006	0.010
D	4.700	5.100	0.185	0.200
E	3.800	4.000	0.150	0.157
E1	5.800	6.200	0.228	0.244
e	1.27 BSC		0.050 BSC	
L	0.400	1.270	0.016	0.050
θ	0°	8°	0°	8°

NOTES:
 1. Body dimensions do not include mode flash or protrusion.
 2. This drawing is subject to change without notice.

PACKAGE OUTLINE DIMENSIONS

MSOP-8

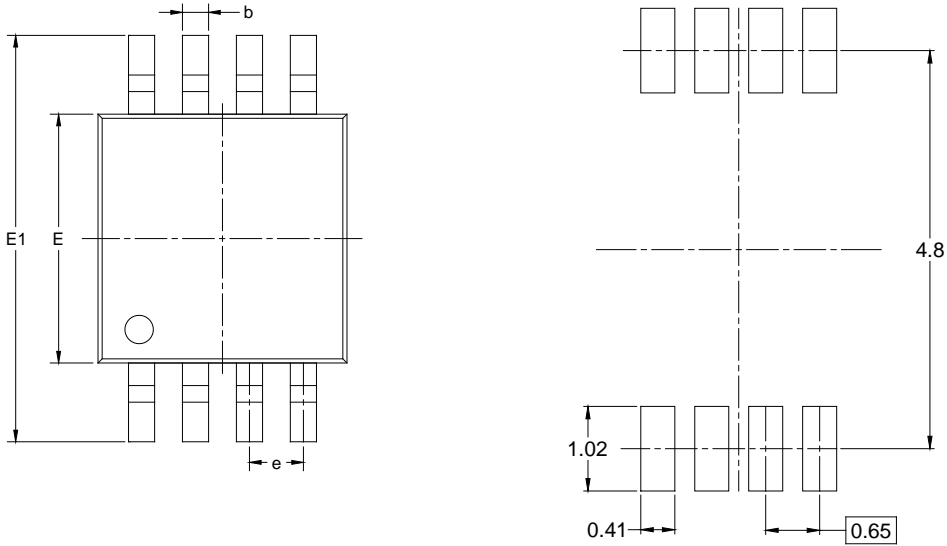

RECOMMENDED LAND PATTERN (Unit: mm)

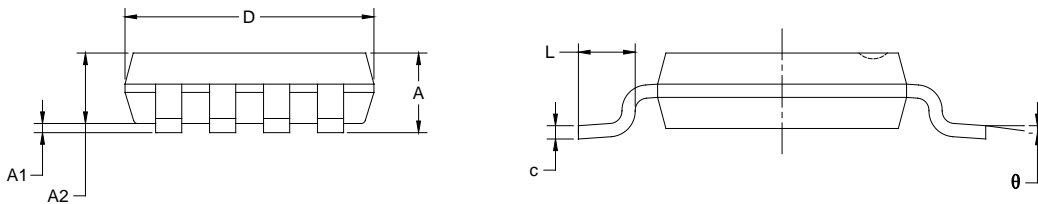

Symbol	Dimensions In Millimeters		Dimensions In Inches	
	MIN	MAX	MIN	MAX
A	0.820	1.100	0.032	0.043
A1	0.020	0.150	0.001	0.006
A2	0.750	0.950	0.030	0.037
b	0.250	0.380	0.010	0.015
c	0.090	0.230	0.004	0.009
D	2.900	3.100	0.114	0.122
E	2.900	3.100	0.114	0.122
E1	4.750	5.050	0.187	0.199
e	0.650 BSC		0.026 BSC	
L	0.400	0.800	0.016	0.031
θ	0°	6°	0°	6°

- NOTES:
1. Body dimensions do not include mode flash or protrusion.
 2. This drawing is subject to change without notice.

PACKAGE OUTLINE DIMENSIONS

TSSOP-8

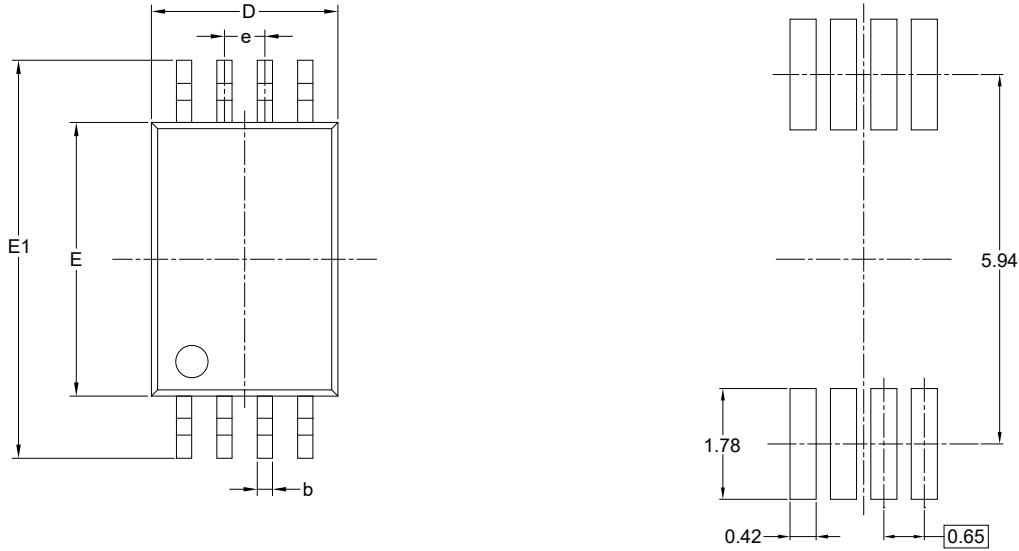

RECOMMENDED LAND PATTERN (Unit: mm)

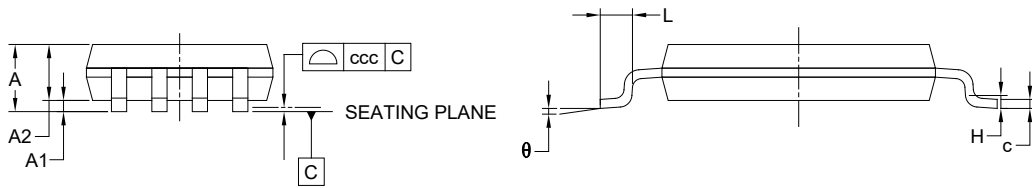

Symbol	Dimensions In Millimeters		
	MIN	MOD	MAX
A	-	-	1.200
A1	0.050	-	0.150
A2	0.800	-	1.050
b	0.190	-	0.300
c	0.090	-	0.200
D	2.900	-	3.100
E	4.300	-	4.500
E1	6.200	-	6.600
e	0.650 BSC		
L	0.450	-	0.750
H	0.250 TYP		
θ	0°	-	8°
ccc	0.100		

NOTES:

1. This drawing is subject to change without notice.
2. The dimensions do not include mold flashes, protrusions or gate burrs.
3. Reference JEDEC MO-153.

PACKAGE INFORMATION

TAPE AND REEL INFORMATION

REEL DIMENSIONS

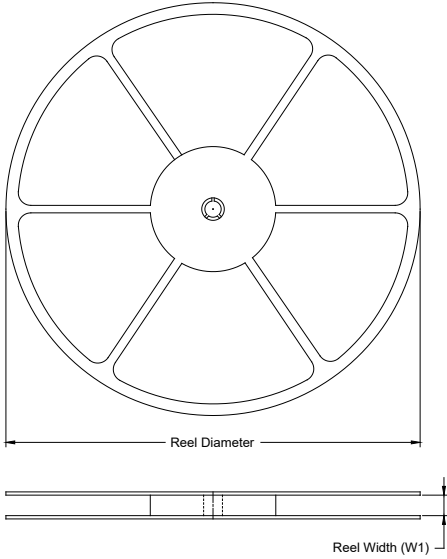

TAPE DIMENSIONS

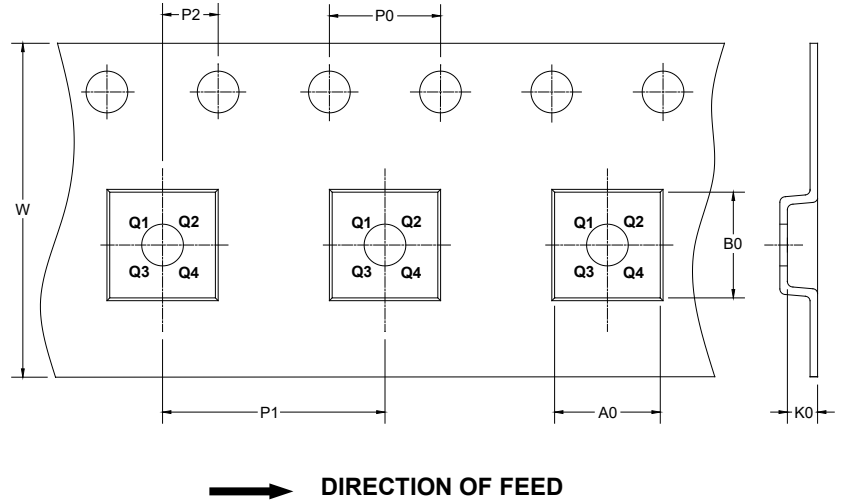

NOTE: The picture is only for reference. Please make the object as the standard.

KEY PARAMETER LIST OF TAPE AND REEL

Package Type	Reel Diameter	Reel Width W1 (mm)	A0 (mm)	B0 (mm)	K0 (mm)	P0 (mm)	P1 (mm)	P2 (mm)	W (mm)	Pin1 Quadrant
UTDFN-2x2-8BL	7"	9.5	2.25	2.25	0.75	4.0	4.0	2.0	8.0	Q1
SOIC-8	13"	12.4	6.40	5.40	2.10	4.0	8.0	2.0	12.0	Q1
MSOP-8	13"	12.4	5.20	3.30	1.50	4.0	8.0	2.0	12.0	Q1
TSSOP-8	13"	12.4	6.76	3.30	1.80	4.0	8.0	2.0	12.0	Q1

DD0001

PACKAGE INFORMATION

CARTON BOX DIMENSIONS



NOTE: The picture is only for reference. Please make the object as the standard.

KEY PARAMETER LIST OF CARTON BOX

Reel Type	Length (mm)	Width (mm)	Height (mm)	Pizza/Carton
7" (Option)	368	227	224	8
7"	442	410	224	18
13"	386	280	370	5

DD0002

单击下面可查看定价，库存，交付和生命周期等信息

[>>SGMICRO\(圣邦微电子\)](#)