

P-Channel Enhancement Mode MOSFET

Feature

- 30V/-4.1A, $R_{DS(ON)} = 80\text{m}\Omega(\text{MAX}) @ V_{GS} = -10\text{V}$.
 $R_{DS(ON)} = 100\text{m}\Omega(\text{MAX}) @ V_{GS} = -4.5\text{V}$.
- Super High dense cell design for extremely low $R_{DS(ON)}$
- Reliable and Rugged
- SC-59 for Surface Mount Package
- Marking:A7XA

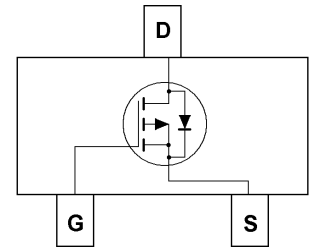

SC-59

Applications

- Power Management
- Portable Equipment and Battery Powered Systems.

Absolute Maximum Ratings $T_A=25^\circ\text{C}$ Unless Otherwise noted

Parameter	Symbol	Limit	Units
Drain-Source Voltage	V_{DS}	-30	V
Gate-Source Voltage	V_{GS}	± 20	V
Drain Current-Continuous	I_D	-4.1	A

Electrical Characteristics $T_A=25^\circ\text{C}$ Unless Otherwise noted

Parameter	Symbol	Test Conditions	Min	Typ.	Max	Units
Off Characteristics						
Drain to Source Breakdown Voltage	BVDSS	$V_{GS}=0\text{V}, I_D=-250\mu\text{A}$	-30	-	-	V
Zero-Gate Voltage Drain Current	I_{DSS}	$V_{DS}=-30\text{V}, V_{GS}=0\text{V}$	-	-	-1	μA
Gate Body Leakage Current, Forward	I_{GSSF}	$V_{GS}=20\text{V}, V_{DS}=0\text{V}$	-	-	100	nA
Gate Body Leakage Current, Reverse	I_{GSSR}	$V_{GS}=-20\text{V}, V_{DS}=0\text{V}$	-	-	-100	nA
On Characteristics						
Gate Threshold Voltage	$V_{GS(th)}$	$V_{GS}=V_{DS}, I_D=-250\mu\text{A}$	-1.0	-	-3.0	V
Static Drain-source On-Resistance	$R_{DS(ON)}$	$V_{GS}=-10\text{V}, I_D=-4.1\text{A}$	-	65	80	$\text{m}\Omega$
		$V_{GS}=-4.5\text{V}, I_D=-4.0\text{A}$	-	85	100	$\text{m}\Omega$
Drain-Source Diode Characteristics and Maximum Ratings						
Drain-Source Diode Forward Voltage	VSD	$V_{GS}=0\text{V}, I_S=-1.0\text{A}$			-1.2	V

Typical Characteristics

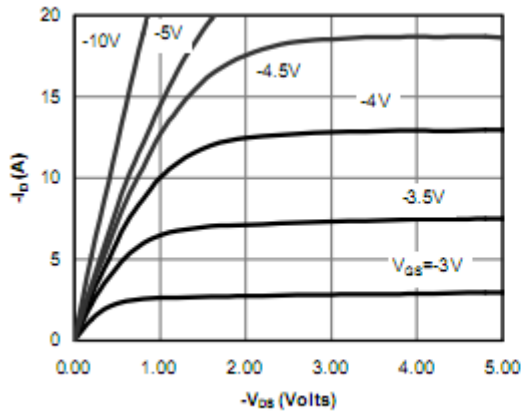

Figure 1: On-Region Characteristics

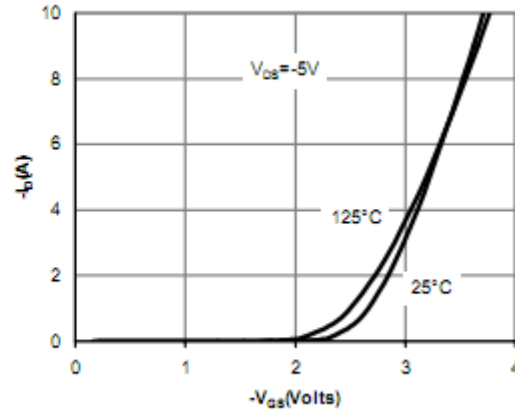

Figure 2: Transfer Characteristics

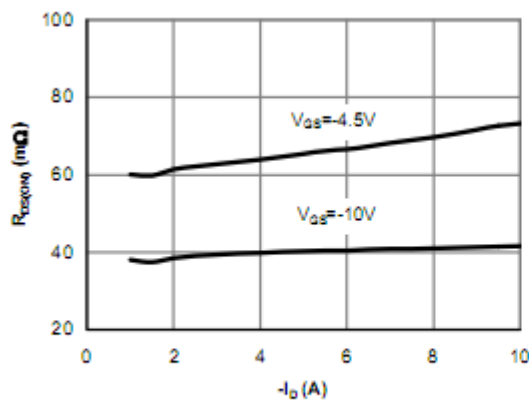

Figure 3: On-Resistance vs. Drain Current and Gate Voltage

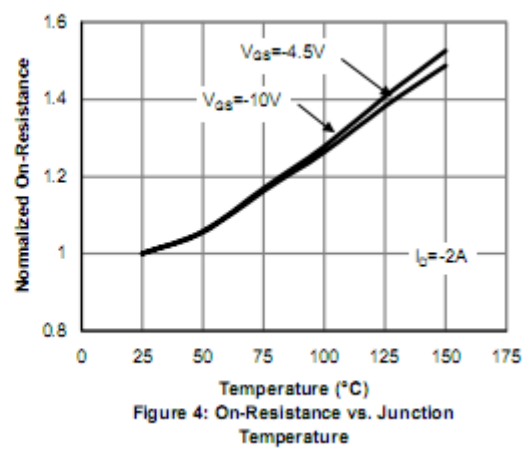

Figure 4: On-Resistance vs. Junction Temperature

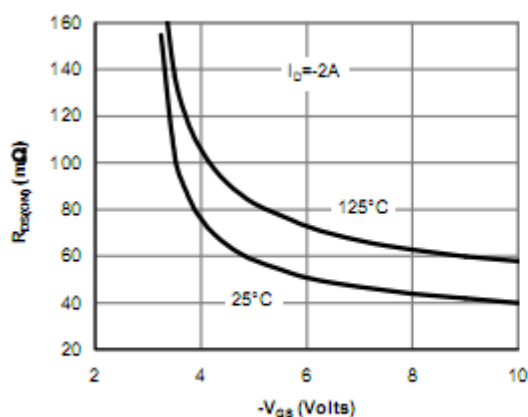

Figure 5: On-Resistance vs. Gate-Source Voltage

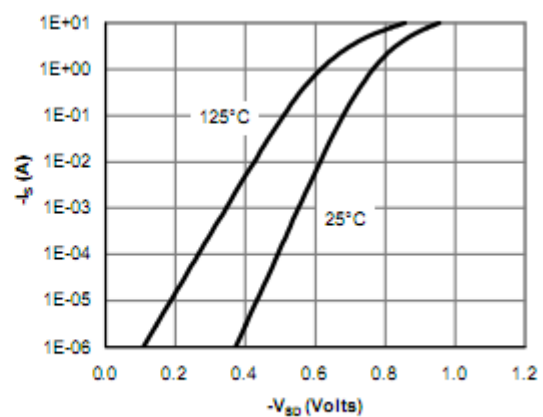

Figure 6: Body-Diode Characteristics

Typical Characteristics

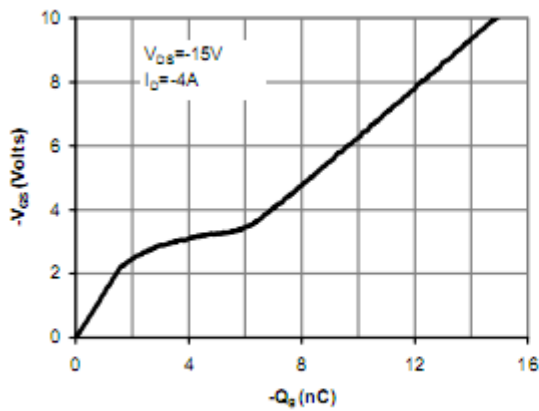

Figure 7: Gate-Charge Characteristics

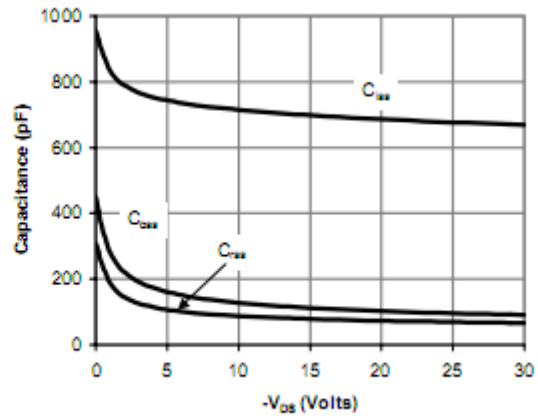

Figure 8: Capacitance Characteristics

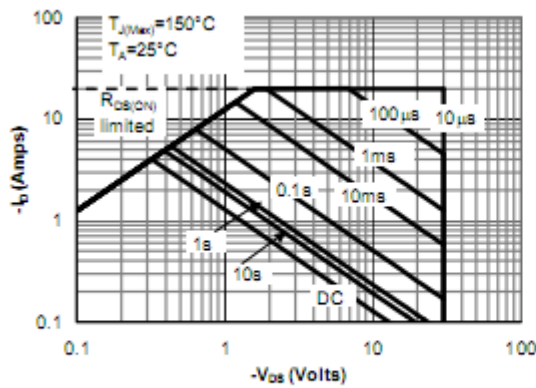

Figure 9: Maximum Forward Biased Safe Operating Area (Note E)

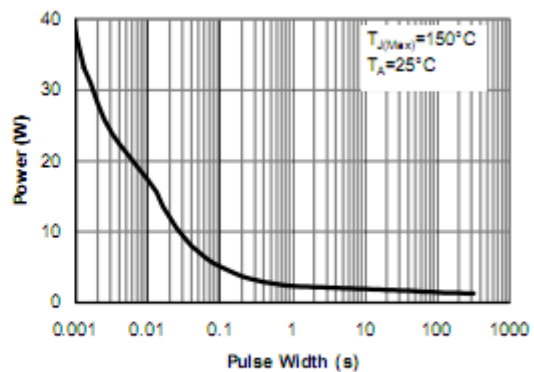

Figure 10: Single Pulse Power Rating Junction-to-Ambient (Note E)

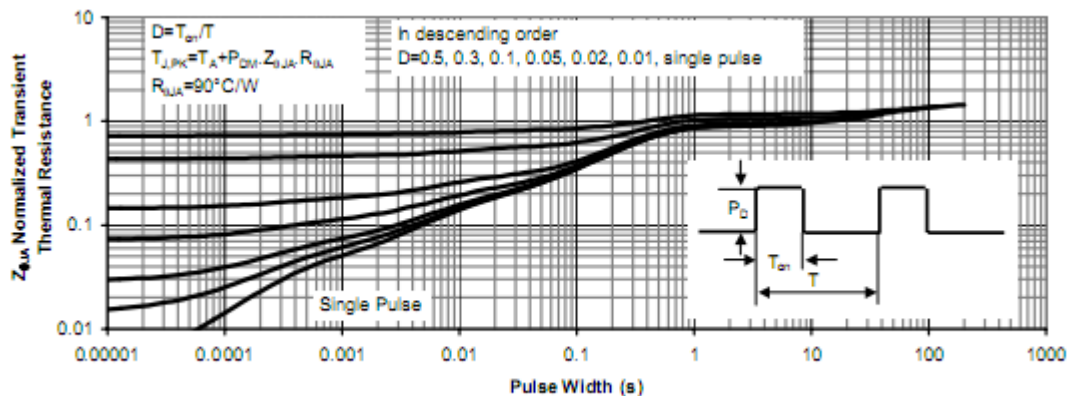
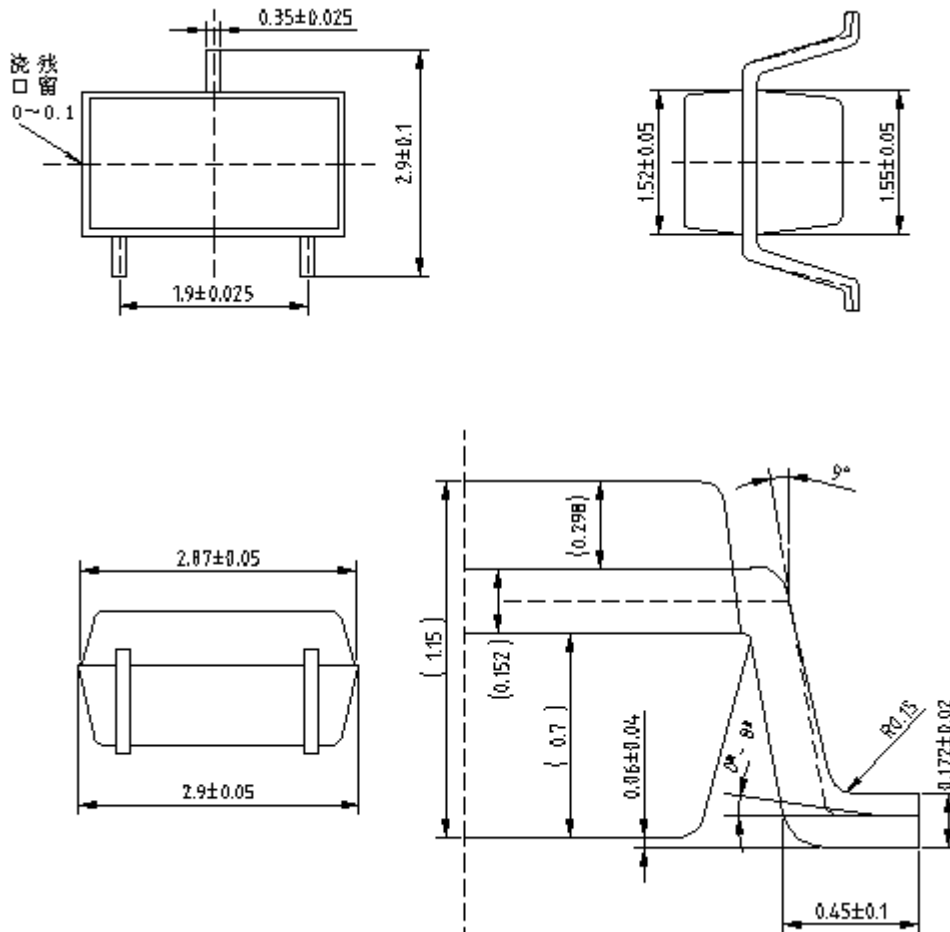

Figure 11: Normalized Maximum Transient Thermal Impedance

Package Outline Dimensions (UNIT: mm)

SC-59



单击下面可查看定价，库存，交付和生命周期等信息

[>>SHIKUES\(时科\)](#)