

N-Channel Enhancement Mode MOSFET

Features

- Surface-mounted package
- Extremely low threshold voltage
- Advanced trench cell design
- ESD protected (HBM > 2KV)

Applications

- Portable appliances

Quick reference

- $BV \cong 60\text{ V}$ $P_{tot} \cong 0.83\text{ W}$ $ID \cong 0.43\text{ A}$
- $R_{DS(ON)} \cong 3\ \Omega @ V_{GS} = 10\text{ V}$
- $R_{DS(ON)} \cong 4\ \Omega @ V_{GS} = 4.5\text{ V}$

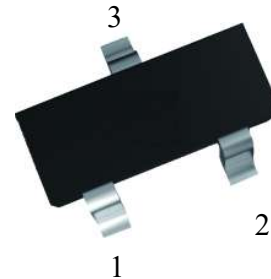

Pin Description

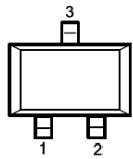
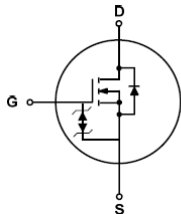
Pin Description	Simplified Outline	Symbol
1 Gate(G)		
2 Source(S)		
3 Drain(D)		

Limiting Values

Symbol	Parameter	Conditions	Min	Max	Unit
V_{DS}	Drain-Source Voltage	$T_A = 25\text{ }^\circ\text{C}$	-	60	V
V_{GS}	Gate-Source Voltage	$T_A = 25\text{ }^\circ\text{C}$	-	± 20	V
I_D^*	Drain Current	$T_A = 25\text{ }^\circ\text{C}, V_{GS} = 10\text{ V}$	-	0.43	A
I_{DM}^{***}	Pulsed Drain Current	$T_A = 25\text{ }^\circ\text{C}, V_{GS} = 10\text{ V}$	-	1.7	A
P_{tot}^*	Total Power Dissipation	$T_A = 25\text{ }^\circ\text{C}$	-	0.83	W
		$T_A = 100\text{ }^\circ\text{C}$	-	0.33	
T_{stg}	Storage Temperature		- 55	150	$^\circ\text{C}$
T_J	Junction Temperature		-	150	$^\circ\text{C}$
I_S^*	Diode Forward Current	$T_A = 25\text{ }^\circ\text{C}$	-	0.4	A
$R_{\theta JA}^*$	Thermal Resistance- Junction to Ambient		-	150	$^\circ\text{C} / \text{W}$

Notes : * Surface Mounted on 1 in² pad area, t ≤ 10 sec ** Pulse width ≤ 300 μs, duty cycle ≤ 2 %

Electrical Characteristics (TA = 25 ° C Unless Otherwise Noted)

Symbol	Parameter	Conditions	Min	Typ	Max	Unit
Static Characteristics						
BV_{DSS}	Drain-Source Breakdown Voltage	$V_{GS} = 0\text{ V}, I_{DS} = 250\ \mu\text{A}$	60	-	-	V
$V_{GS(th)}$	Gate Threshold Voltage	$V_{DS} = V_{GS}, I_{DS} = 250\ \mu\text{A}$	0.9	1.6	2.5	V
I_{DSS}	Drain Leakage Current	$V_{DS} = 48\text{ V}, V_{GS} = 0\text{ V}$	-	-	1	μA
		$T_J = 85\text{ }^\circ\text{C}$	-	-	30	μA
I_{GSS}	Gate Leakage Current	$V_{GS} = \pm 20\text{ V}, V_{DS} = 0\text{ V}$	-	-	± 10	μA
$R_{DS(ON)}^a$	On-State Resistance	$V_{GS} = 10\text{ V}, I_{DS} = 0.4\text{ A}$	-	1.9	3.0	Ω
		$V_{GS} = 4.5\text{ V}, I_{DS} = 0.3\text{ A}$	-	2.4	4.0	
Diode Characteristics						
V_{SD}^a	Diode Forward Voltage	$I_{SD} = 0.4\text{ A}, V_{GS} = 0\text{ V}$	-	0.7	1.3	V
t_{rr}	Reverse Recovery Time	$I_{SD} = 0.4\text{ A}, dI_{SD}/dt = 100\text{ A}/\mu\text{s}$	-	40	-	ns
Q_{rr}	Reverse Recovery Charge		-	40	-	nC
Dynamic Characteristics^b						
R_G	Gate Resistance	$V_{GS} = V_{DS} = 0\text{ V}, F = 1\text{ MHz}$	-	130	-	Ω
C_{iss}	Input Capacitance	$V_{GS} = 0\text{ V}, V_{DS} = 25\text{ V}$ Frequency = 1 MHz	-	30	-	pF
C_{oss}	Output Capacitance		-	4.2	-	
C_{rss}	Reverse Transfer Capacitance		-	3	-	
$t_{d(on)}$	Turn-on Delay Time	$V_{DS} = 30\text{ V}, V_{GEN} = 10\text{ V},$ $R_G = 25\ \Omega, R_L = 150\ \Omega,$ $I_{DS} = 0.2\text{ A}$	-	3.9	9	ns
t_r	Turn-on Rise Time		-	3.5	8	
$t_{d(off)}$	Turn-off Delay Time		-	16	40	
t_f	Turn-off Fall Time		-	10	20	
Q_g	Total Gate Charge	$V_{GS} = 4.5\text{ V}, V_{DS} = 10\text{ V},$ $I_{DS} = 0.4\text{ A}$	-	305	-	pC
Q_{gs}	Gate-Source Charge		-	85	-	
Q_{gd}	Gate-Drain Charge		-	205	-	

 Notes : a : Pulse test ; pulse width $\leq 300\ \mu\text{s}$, duty cycle $\leq 2\%$

b : Guaranteed by design, not subject to production testing

Typical Characteristics

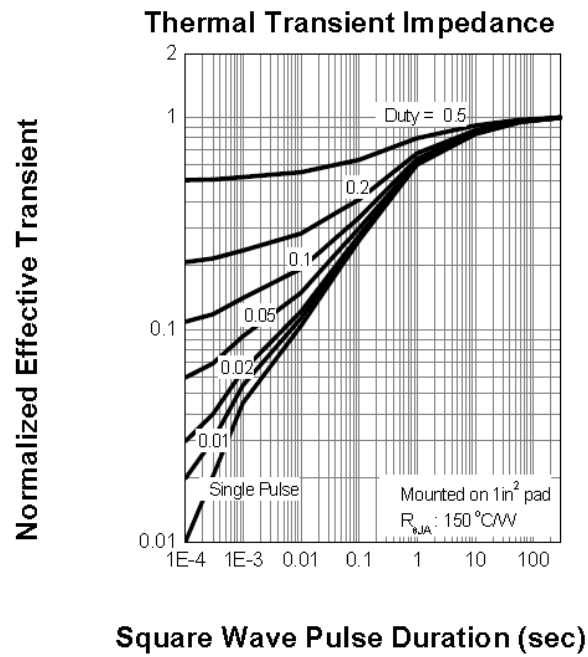
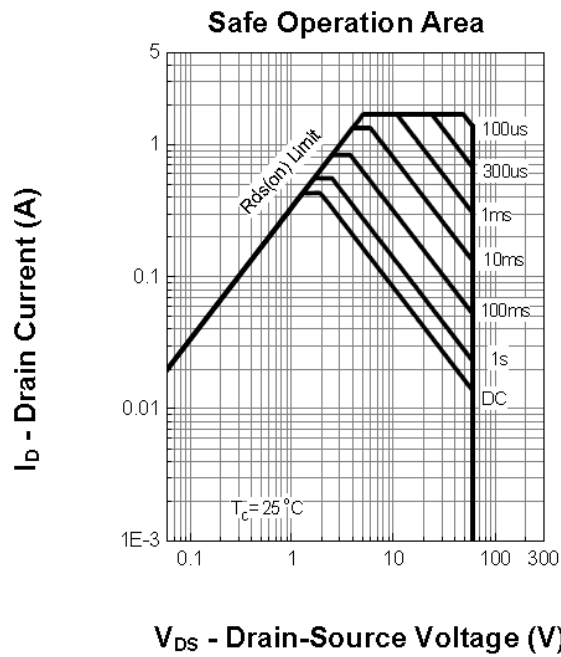
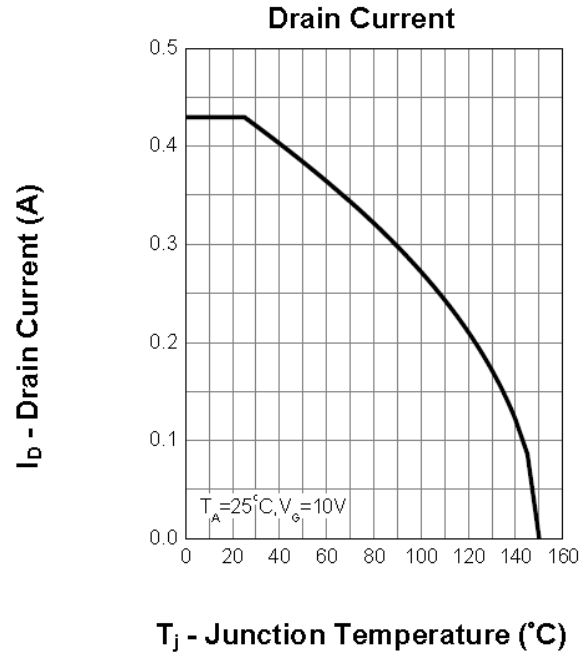
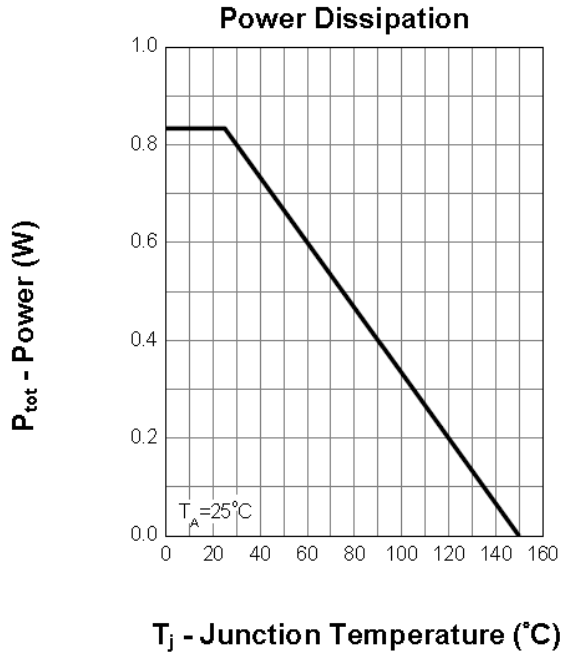

Output Characteristics

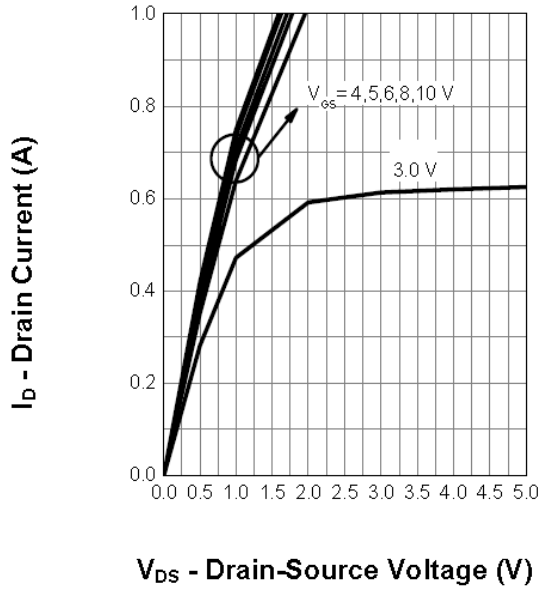

Drain-Source On Resistance

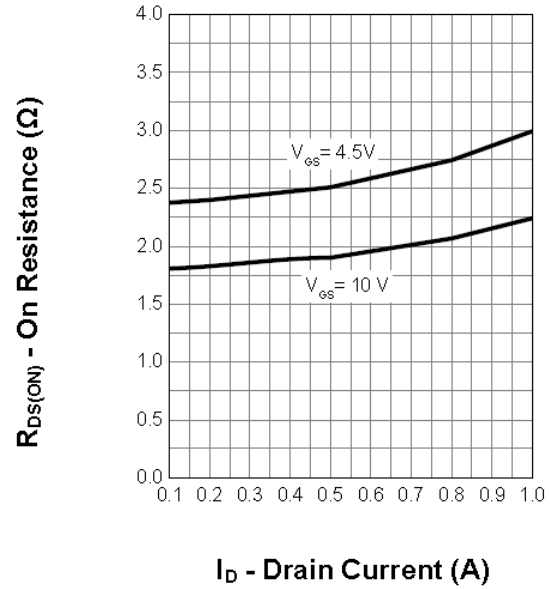

Transfer Characteristics

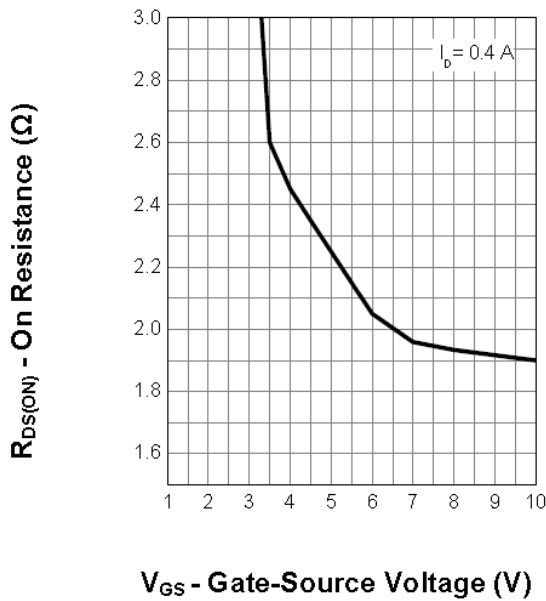

Gate Threshold Voltage

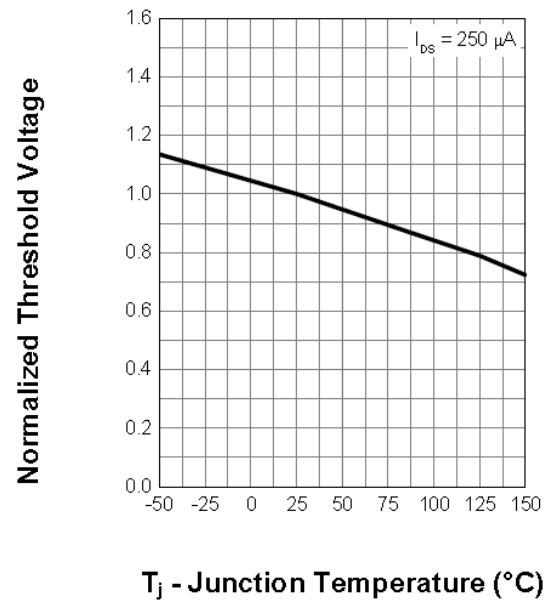

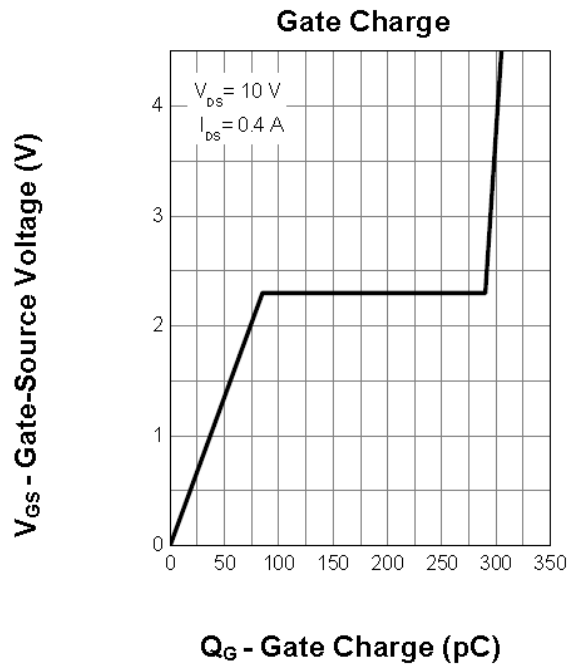
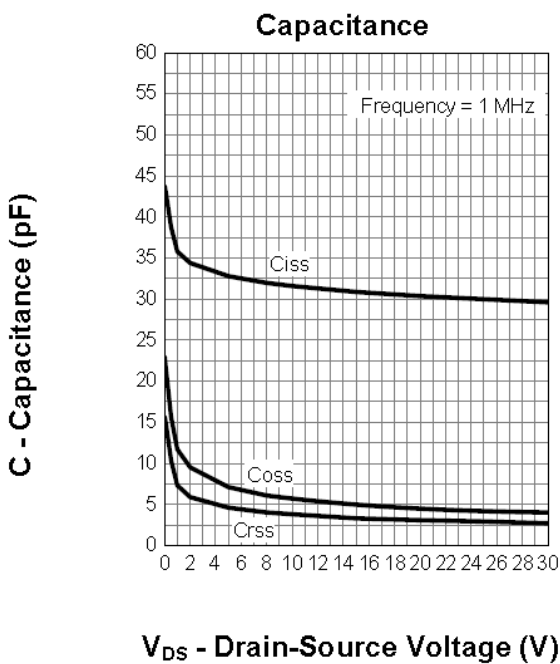
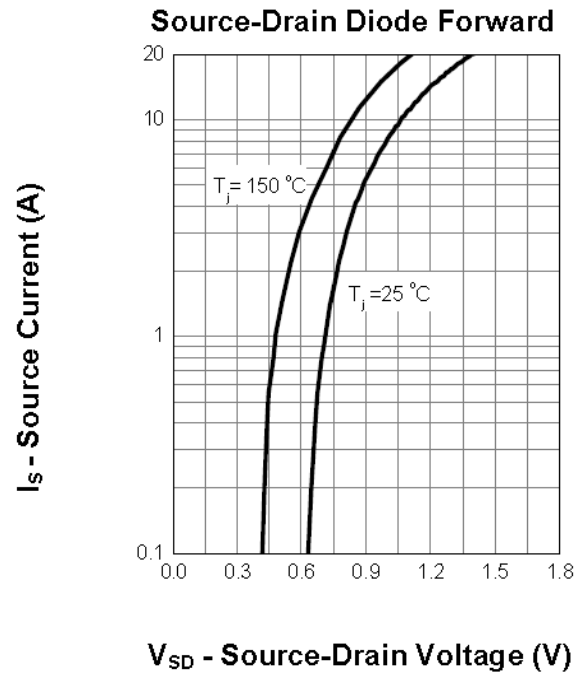
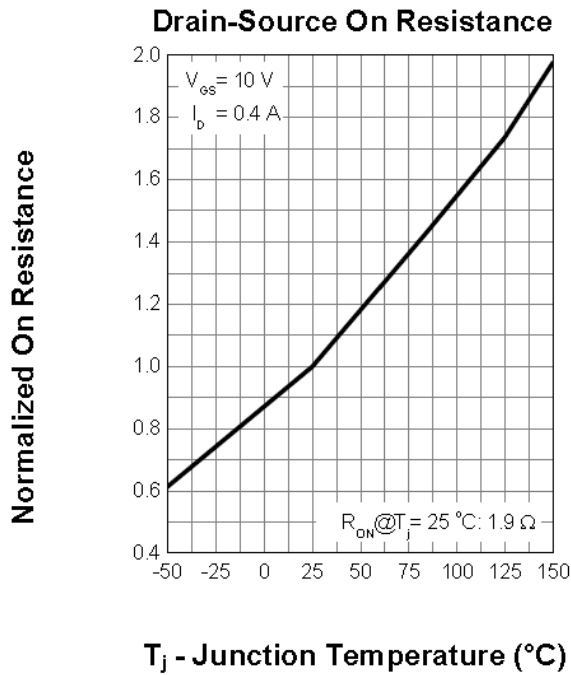

Package Dimensions
SOT-23

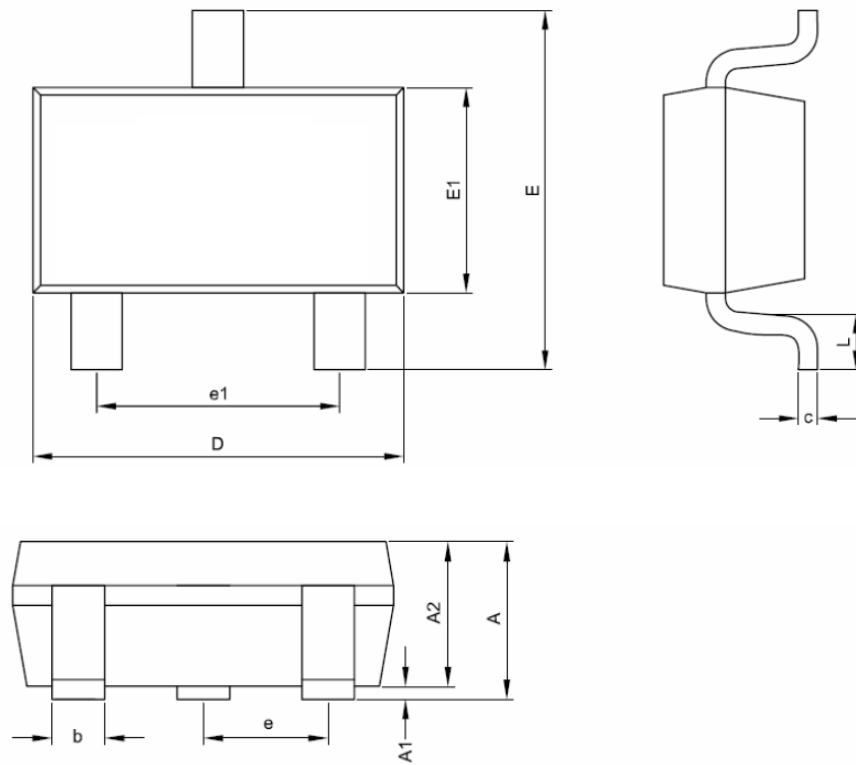

Symbol	Dimensions In Millimeters	
	MIN.	MAX.
A	—	1.12
A1	0.00	0.1
A2	0.90	1.02
D	2.90 BSC	
E	2.40 BSC	
E1	1.20	1.40
c	0.08	0.25
b	0.30	0.50
e	0.95 BSC	
e1	1.90 BSC	
L	0.20	0.60

单击下面可查看定价，库存，交付和生命周期等信息

[>>SHIKUES\(时科\)](#)