

650V N-ch Planar MOSFET

| | | |
|------------|-------------------|-------|
| BV_{DSS} | $R_{DS(ON),typ.}$ | I_D |
| 650V | 0.60Ω | 12A |

General Features

- RoHS Compliant
- $R_{DS(ON),typ.}=0.60\ \Omega@V_{GS}=10V$
- Low Gate Charge Minimize Switching Loss
- Fast Recovery Body Diode

Applications

- Adaptor
- Charger
- SMPS Standby Power

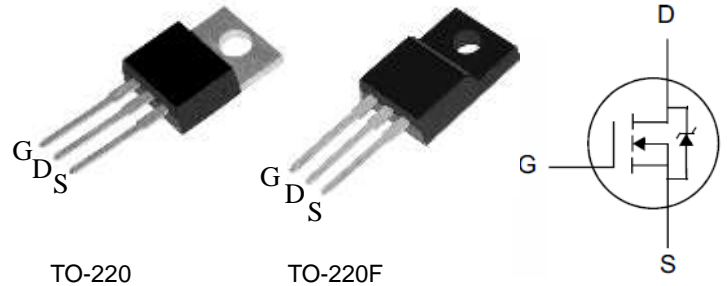

Ordering Information

| | | |
|------------|------------|-------------|
| PART NUMBE | SK12N65B-T | SK12N65B-TF |
| PACKAGE | TO-220 | TO-220F |

Package No to Scale

Absolute Maximum Ratings

$T_C=25^\circ\text{C}$ unless otherwise specified

| Symbol | Parameter | SK12N65B-T | SK12N65B-TF | Unit |
|-------------------|---|------------|-------------|------|
| V_{DSS} | Drain-to-Source Voltage | 650 | | V |
| V_{GSS} | Gate-to-Source Voltage | ±30 | | |
| I_D | Continuous Drain Current | 12 | | A |
| I_{DM} | Pulsed Drain Current at $V_{GS}=10V$ | 48 | | |
| E_{AS} | Single Pulse Avalanche Energy | 450 | | mJ |
| P_D | Power Dissipation | 125 | 73 | W |
| | Derating Factor above 25°C | 1.0 | 0.58 | W/°C |
| T_L | Soldering Temperature Distance of 1.6mm from case for 10 seconds | 300 | | °C |
| T_J & T_{STG} | Operating and Storage Temperature Range | -55 to 150 | | |

Caution: Stresses greater than those listed in the "Absolute Maximum Ratings" may cause permanent damage to the device.

Thermal Characteristics

| Symbol | Parameter | SK12N65B-T | SK12N65B-TF | Unit |
|-----------------|---|------------|-------------|------|
| $R_{\theta JC}$ | Thermal Resistance, Junction-to-Case | 1.0 | 1.71 | °C/W |
| $R_{\theta JA}$ | Thermal Resistance, Junction-to-Ambient | 62 | 100 | |

Electrical Characteristics

OFF Characteristics

$T_J = 25^\circ\text{C}$ unless otherwise specified

| Symbol | Parameter | Min. | Typ. | Max. | Unit | Test Conditions |
|------------|-----------------------------------|------|------|------|------|---|
| BV_{DSS} | Drain-to-Source Breakdown Voltage | 650 | -- | -- | V | $V_{GS}=0V, I_D=250\mu A$ |
| I_{DSS} | Drain-to-Source Leakage Current | -- | -- | 1 | uA | $V_{DS}=650V, V_{GS}=0V$ |
| | | -- | -- | 100 | | $V_{DS}=520V, V_{GS}=0V, T_J=125^\circ\text{C}$ |
| I_{GSS} | Gate-to-Source Leakage Current | -- | -- | +100 | nA | $V_{GS}=+30V, V_{DS}=0V$ |
| | | -- | -- | -100 | | $V_{GS}=-30V, V_{DS}=0V$ |

ON Characteristics

$T_J = 25^\circ\text{C}$ unless otherwise specified

| Symbol | Parameter | Min. | Typ. | Max. | Unit | Test Conditions |
|--------------|--------------------------------------|------|------|------|----------|-------------------------------|
| $R_{DS(ON)}$ | Static Drain-to-Source On-Resistance | -- | 0.60 | 0.75 | Ω | $V_{GS}=10V, I_D=6.0A$ |
| $V_{GS(TH)}$ | Gate Threshold Voltage | 2.0 | -- | 4.0 | V | $V_{DS}=V_{GS}, I_D=250\mu A$ |
| gfs | Forward Transconductance | -- | 5.2 | -- | S | $V_{DS}=15V, I_D=6.0A$ |

Dynamic Characteristics

Essentially independent of operating temperature

| Symbol | Parameter | Min. | Typ. | Max. | Unit | Test Conditions |
|-----------|-------------------------------|------|------|------|------|--|
| C_{iss} | Input Capacitance | -- | 1900 | -- | pF | $V_{GS}=0V, V_{DS}=25V, f=1.0\text{MHz}$ |
| C_{rSS} | Reverse Transfer Capacitance | -- | 33 | -- | | |
| C_{oss} | Output Capacitance | -- | 150 | -- | | |
| Q_g | Total Gate Charge | -- | 52 | -- | nC | $V_{DD}=480V, I_D=12A, V_{GS}=0 \text{ to } 10V$ |
| Q_{gs} | Gate-to-Source Charge | -- | 9 | -- | | |
| Q_{gd} | Gate-to-Drain (Miller) Charge | -- | 20 | -- | | |

Resistive Switching Characteristics

Essentially independent of operating temperature

| Symbol | Parameter | Min. | Typ. | Max. | Unit | Test Conditions |
|--------------|---------------------|------|------|------|------|--|
| $t_{d(ON)}$ | Turn-on Delay Time | -- | 25 | -- | nS | $V_{DD}=300V, I_D=12A, V_{GS}=10V, R_g=25\Omega$ |
| t_{rise} | Rise Time | -- | 40 | -- | | |
| $t_{d(OFF)}$ | Turn-Off Delay Time | -- | 150 | -- | | |
| t_{fall} | Fall Time | -- | 60 | -- | | |

Source-Drain Body Diode Characteristics $T_J=25^\circ\text{C}$ unless otherwise specified

| Symbol | Parameter | Min | Typ. | Max. | Unit | Test Conditions |
|----------|--|-----|------|------|---------------|---|
| I_{SD} | Continuous Source Current ^[2] | -- | -- | 12 | A | Integral pn-diode in MOSFET |
| I_{SM} | Pulsed Source Current ^[2] | -- | -- | 48 | | |
| V_{SD} | Diode Forward Voltage | -- | -- | 1.4 | V | $I_S=12\text{A}$, $V_{GS}=0\text{V}$ |
| t_{rr} | Reverse Recovery Time | -- | 420 | -- | ns | $V_{GS}=0\text{V}$ $I_F=I_S$, $di/dt=100\text{A}/\mu\text{s}$ |
| Q_{rr} | Reverse Recovery Charge | -- | 6.0 | -- | μC | |

Note:

[1] $T_J=+25^\circ\text{C}$ to $+150^\circ\text{C}$

[2] Pulse width $\leq 380\mu\text{s}$; duty cycle $\leq 2\%$.

Typical Characteristics

Figure 1. Output Characteristics ($T_J = 25^\circ\text{C}$)

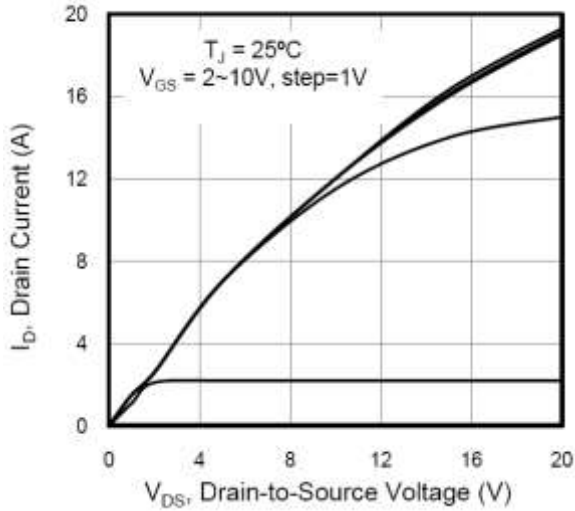

Figure 2. On-Resistance vs. Drain Current

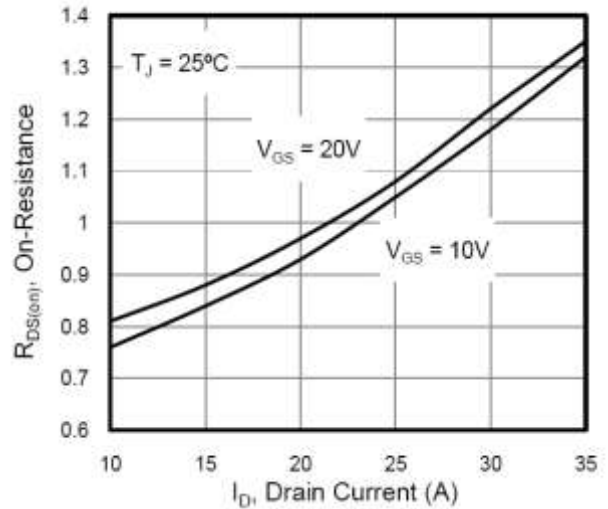

Figure 3. BV_{DSS} vs. Temperature

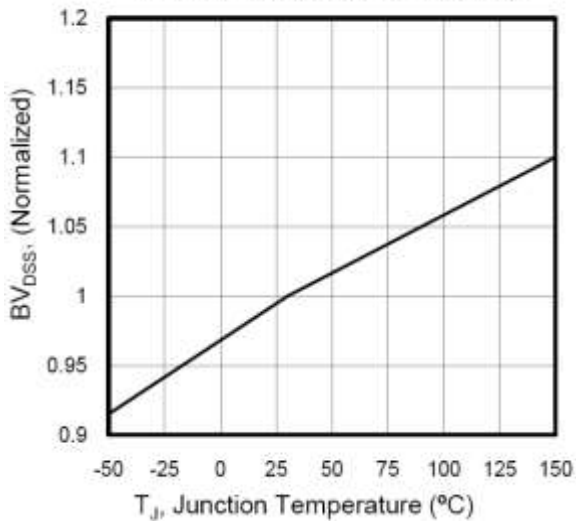

Figure 4. On-Resistance vs. Temperature

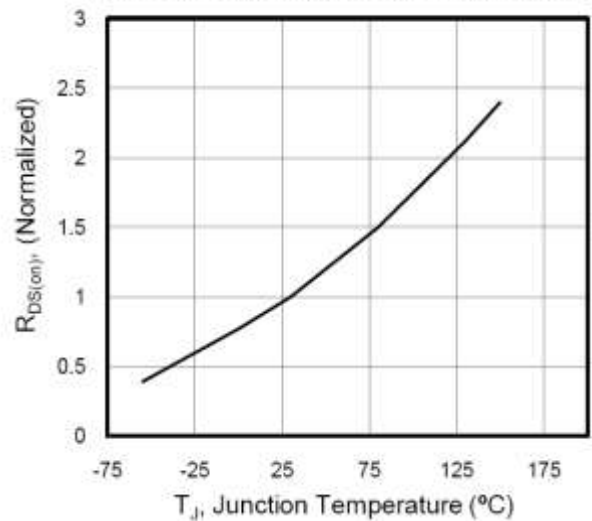

Figure 5. Gate Charge

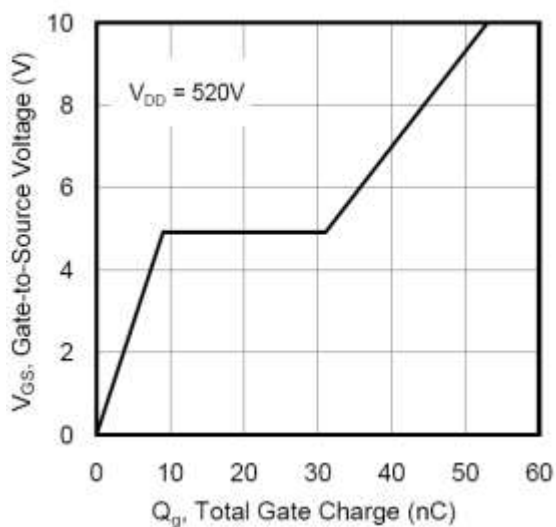
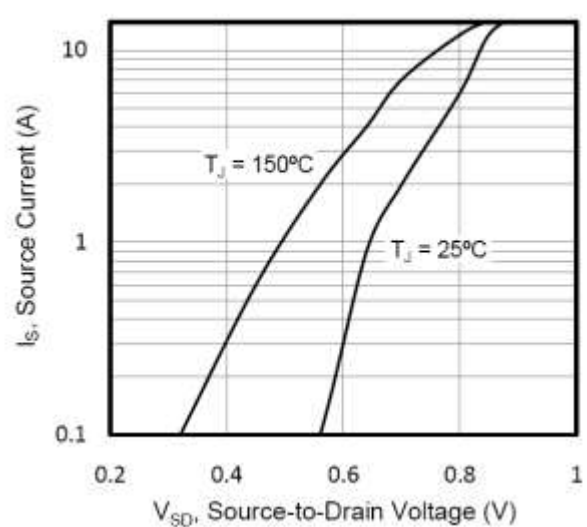

Figure 6. Body Diode Forward Voltage



Typical Characteristics

Figure 7. Safe Operating Area

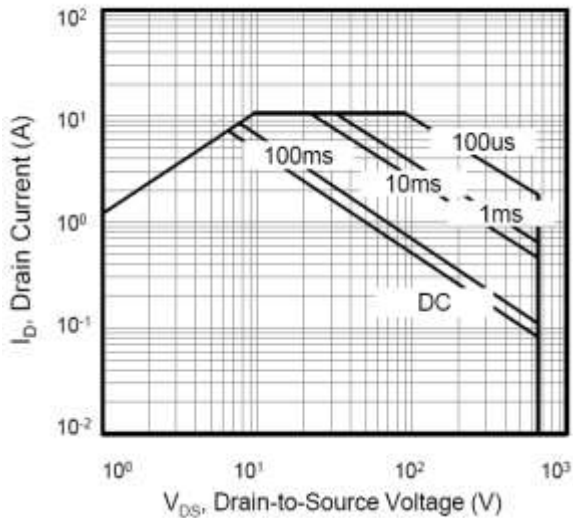

Figure 8. Transient Thermal Impedance

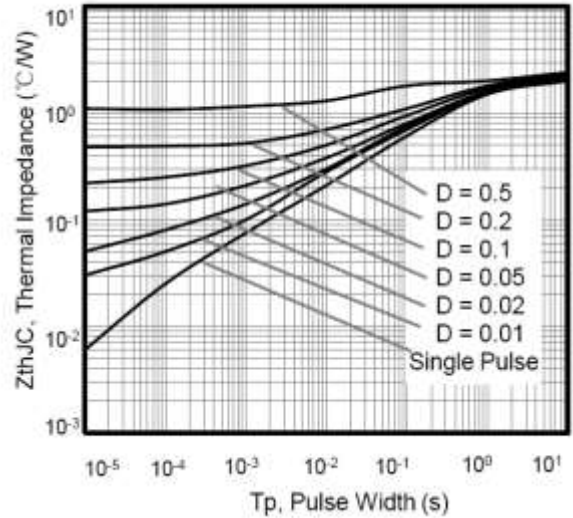

Figure 9. Maximum Continuous Drain Current vs Tc

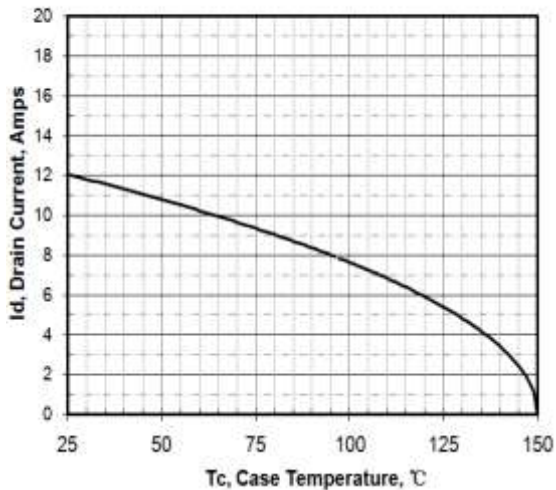

Figure 10. Max. Power Dissipation vs Tc

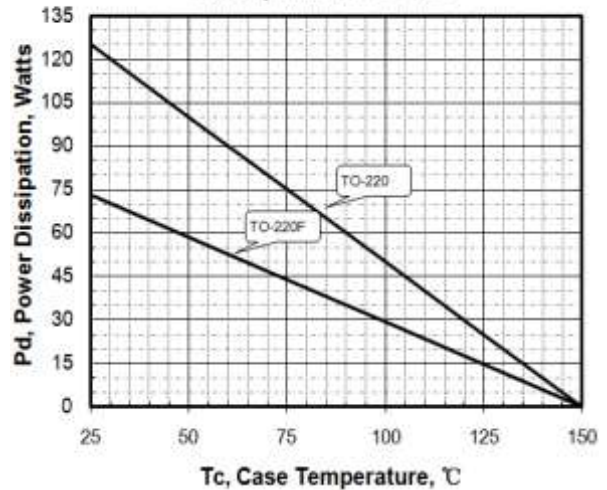
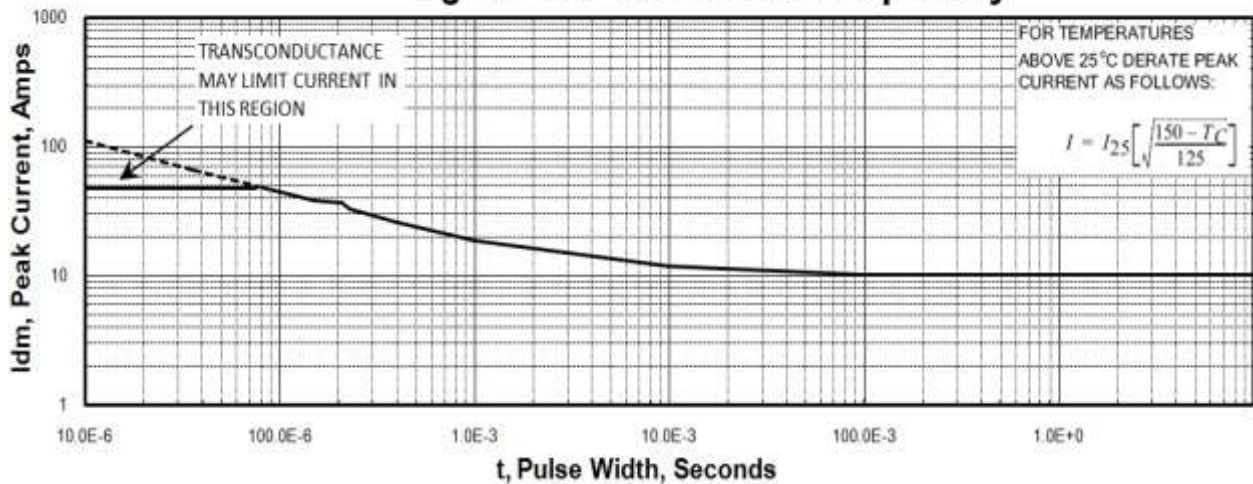

Figure 11. Peak Current Capability



Test Circuits and Waveforms

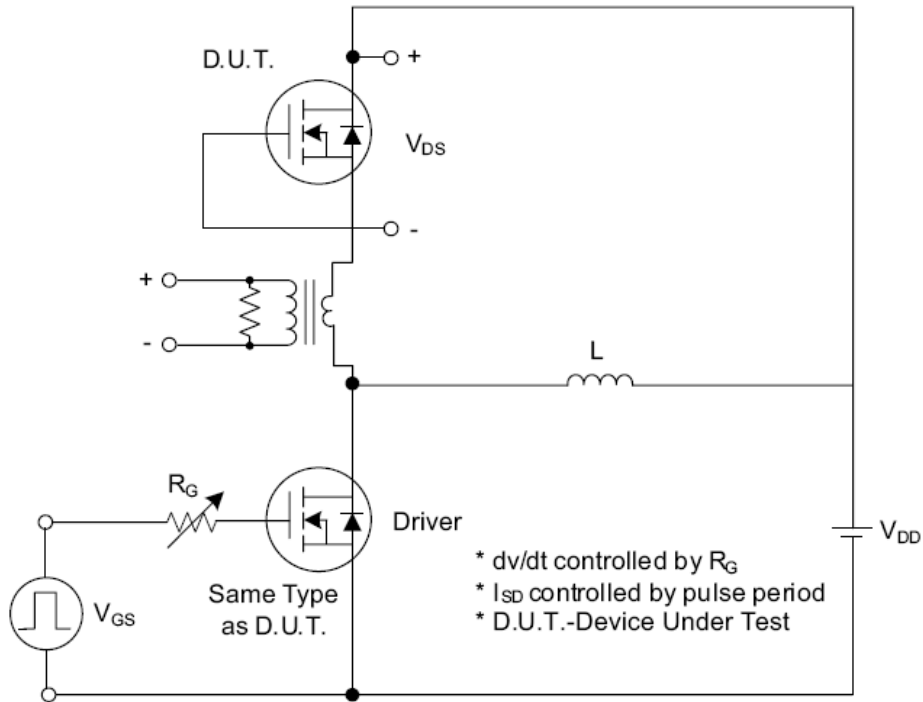

Fig. 1.1 Peak Diode Recovery dv/dt Test Circuit

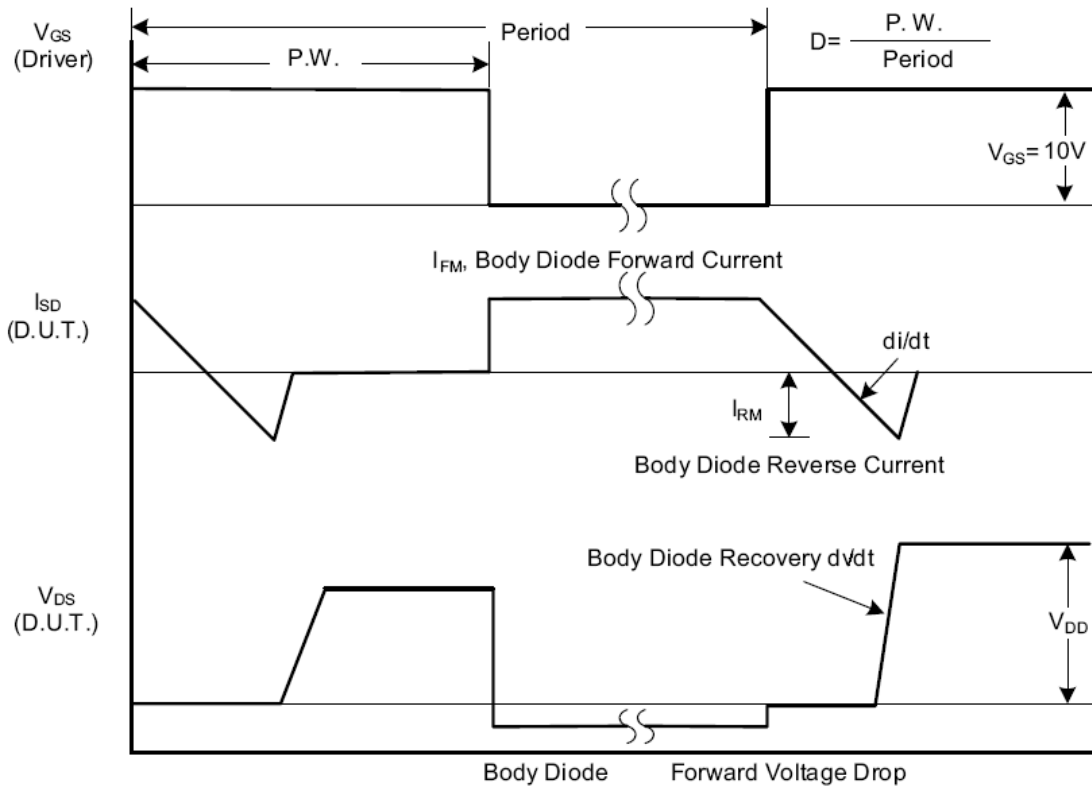

Fig. 1.2 Peak Diode Recovery dv/dt Waveforms

Test Circuits and Waveforms (Cont.)

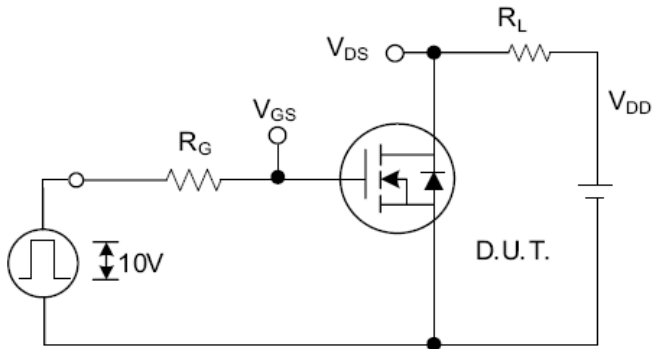

Fig. 2.1 Switching Test Circuit

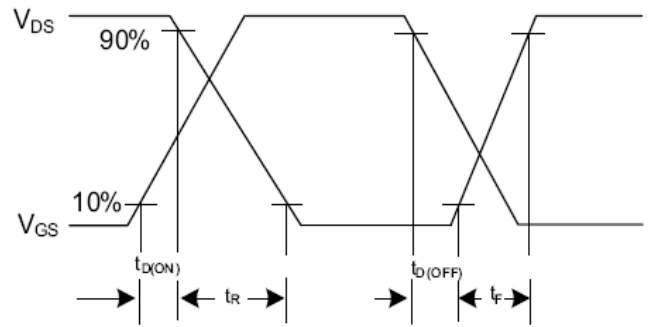

Fig. 2.2 Switching Waveforms

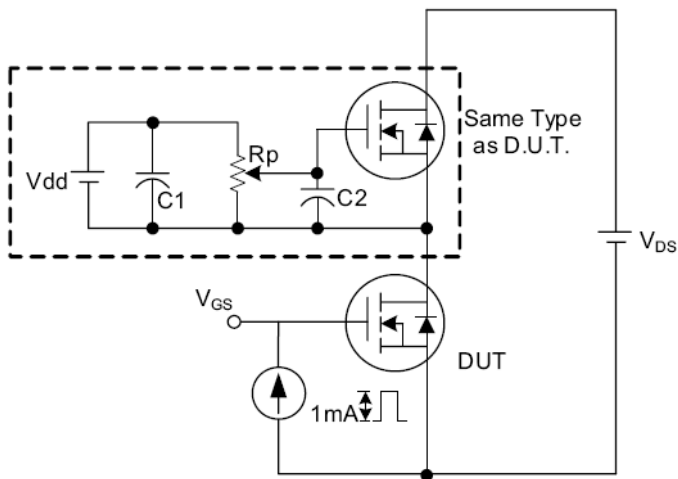

Fig. 3.1 Gate Charge Test Circuit

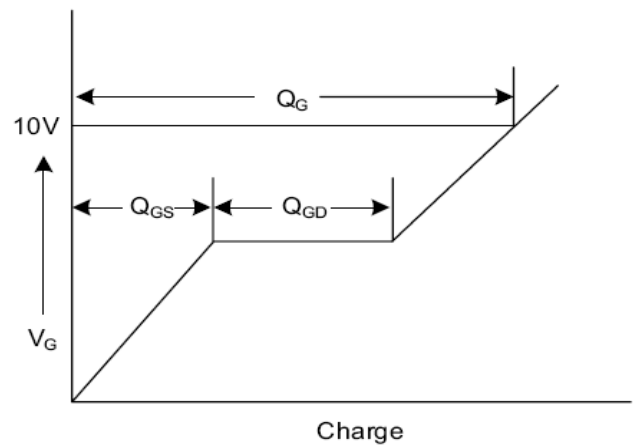

Fig. 3.2 Gate Charge Waveform

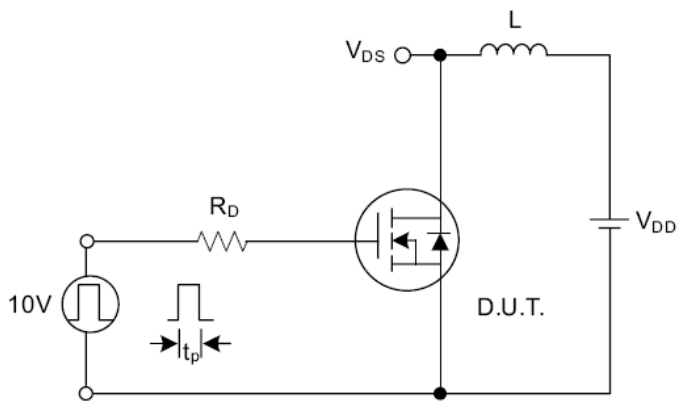

Fig. 4.1 Unclamped Inductive Switching Test Circuit

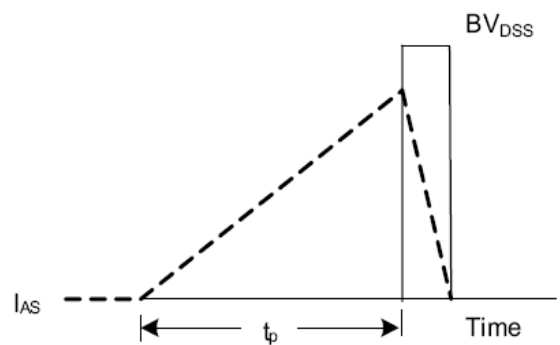
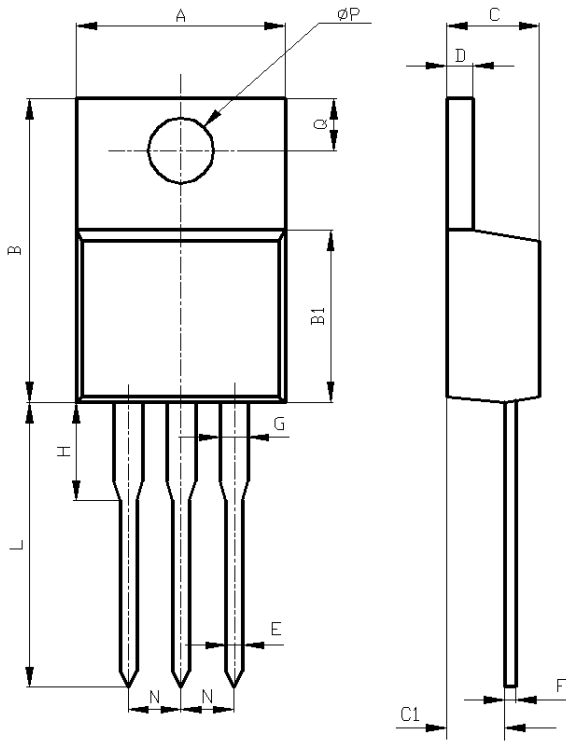

Fig. 4.2 Unclamped Inductive Switching Waveforms

PACKAGE OUTLINE

TO-220



: mm

| | Unit (mm) | |
|-----|-----------|------|
| | MIN | MAX |
| A | 10.1 | 10.5 |
| B | 15.2 | 15.6 |
| B1 | 9.00 | 9.40 |
| C | 4.40 | 4.60 |
| C1 | 2.40 | 3.00 |
| D | 1.20 | 1.40 |
| E | 0.70 | 0.90 |
| F | 0.40 | 0.60 |
| G | 1.17 | 1.37 |
| H | 3.30 | 3.80 |
| L | 13.1 | 13.7 |
| N | 2.34 | 2.74 |
| Q | 2.40 | 3.00 |
| φ P | 3.70 | 3.90 |

PACKAGE OUTLINE

TO-220F

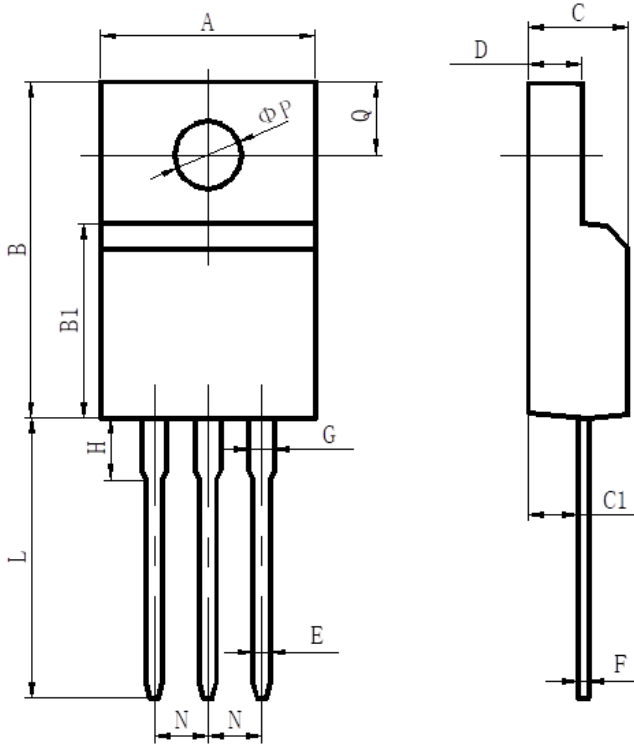

| | Unit (mm) | |
|----------|-----------|-------|
| | MIN | MAX |
| A | 9.70 | 10.30 |
| B | 15.50 | 16.10 |
| B1 | 8.99 | 9.39 |
| C | 4.40 | 4.80 |
| C1 | 2.15 | 2.55 |
| D | 2.50 | 2.90 |
| E | 0.70 | 0.90 |
| F | 0.40 | 0.60 |
| G | 1.12 | 1.42 |
| H | 3.40 | 3.80 |
| L | 12.6 | 13.6 |
| N | 2.34 | 2.74 |
| Q | 3.15 | 3.55 |
| ϕP | 3.00 | 3.30 |

单击下面可查看定价，库存，交付和生命周期等信息

[>>SHIKUES\(时科\)](#)