

## ● Applications

- Strobe DC-DC converters, relay drivers, hammer drivers, lamp drivers, motor drovers

## ● Features

- Low saturation voltage
- Large current capacity
- Very small size making it easy to provide high density, small-sized hybrid IC's
- Halogen free compliance
- High  $\beta$

## ● Specifications

Absolute Maximum Ratings at  $T_a=25^\circ\text{C}$

Parameter	Symbol	Conditions	Ratings	Unit
Collector-to-Base Voltage	$V_{CB0}$		60	V
Collector-to-Emitter Voltage	$V_{CE0}$		20	V
Emitter-to-Base Voltage	$V_{EB0}$		6	V
Collector Current	$I_C$		5	A
Collector Current (Pulse)	$I_{CP}$		8	A

Continued on next page.

## ● Package Dimensions

unit : mm (typ)

7007B-004

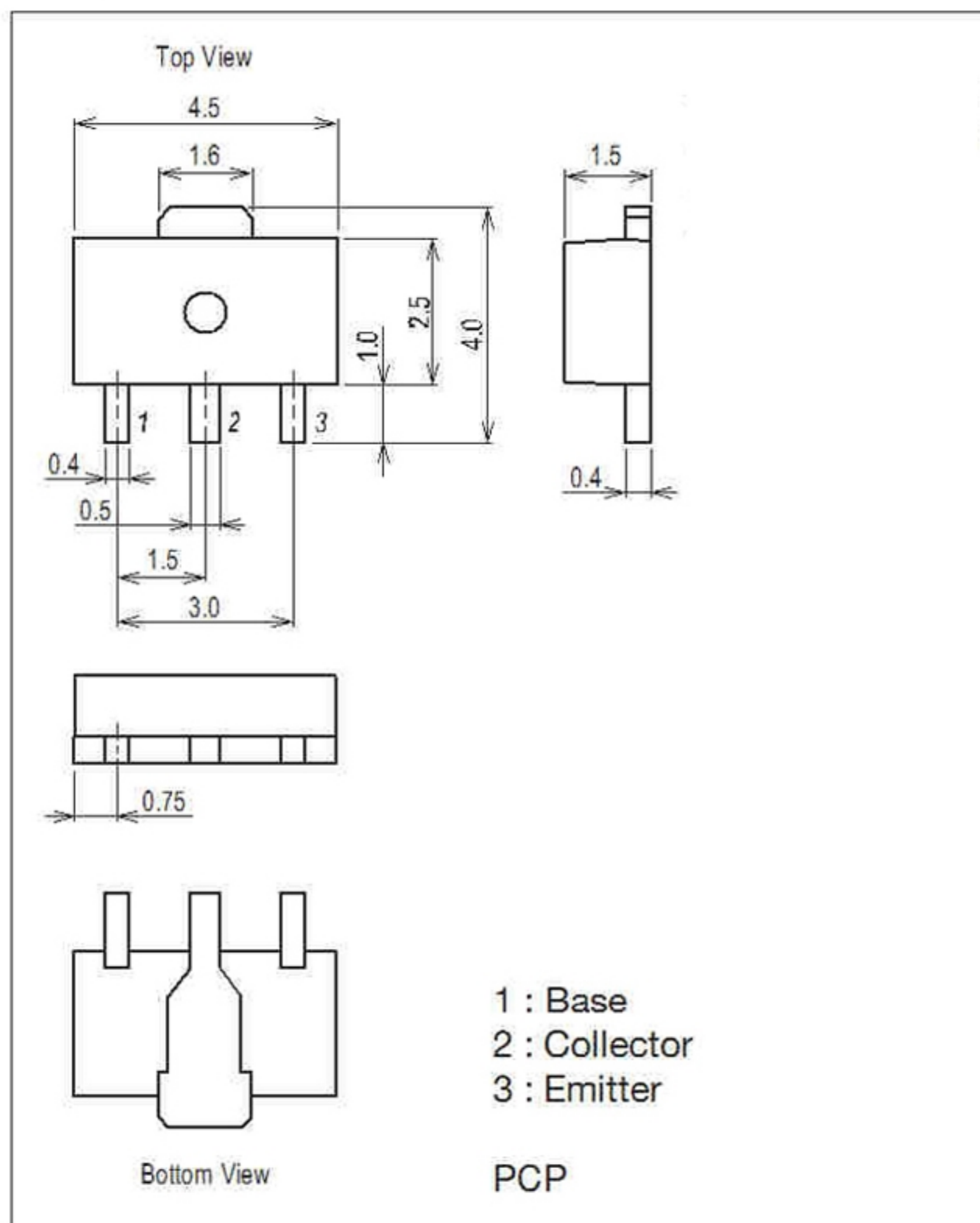

Continued from preceding page.

Parameter	Symbol	Conditions	Ratings	Unit
Collector Dissipation	PC		500	mW
		When mounted on ceramic substrate (250mm <sup>2</sup> ×0.8mm)	1.5	W
Junction Temperature	T <sub>J</sub>		150	°C
Storage Temperature	T <sub>stg</sub>		-55 to +150	°C

Stresses exceeding Maximum Ratings may damage the device. Maximum Ratings are stress ratings only. Functional operation above the Recommended Operating Conditions is not implied. Extended exposure to stresses above the Recommended Operating Conditions may affect device reliability.

### Electrical Characteristics at Ta=25°C

Parameter	Symbol	Conditions	Ratings			Unit
			min	typ	max	
Collector Cutoff Current	I <sub>CBO</sub>	V <sub>CB</sub> =50V, I <sub>E</sub> =0A			100	nA
Emitter Cutoff Current	I <sub>EBO</sub>	V <sub>EB</sub> =5V, I <sub>C</sub> =0A			100	nA
DC Current Gain	h <sub>FE1</sub>	V <sub>CE</sub> =2V, I <sub>C</sub> =0.5A	120*		560*	
	h <sub>FE2</sub>	V <sub>CE</sub> =2V, I <sub>C</sub> =3A	95			
Gain-Bandwidth Product	f <sub>T</sub>	V <sub>CE</sub> =10V, I <sub>C</sub> =50mA		120		MHz
Output Capacitance	C <sub>ob</sub>	V <sub>CB</sub> =10V, f=1MHz		45		pF
Collector-to-Emitter Saturation Voltage	V <sub>CE(sat)</sub>	I <sub>C</sub> =3A, I <sub>B</sub> =60mA			500	mV
Base-to-Emitter Saturation Voltage	V <sub>BE(sat)</sub>	I <sub>C</sub> =3A, I <sub>B</sub> =60mA			1.5	V
Turn-ON Time	t <sub>on</sub>	See specified Test Circuit.		30		ns
Storage Time	t <sub>stg</sub>			300		ns
Fall Time	t <sub>f</sub>			40		ns

\* : The 2SD1628 is classified by 0.5A h<sub>FE</sub> as follows:

Rank	E	F	H	G
h <sub>FE</sub>	120 to 200	160 to 320	200 to 400	280 to 560

### Switching Time Test Circuit

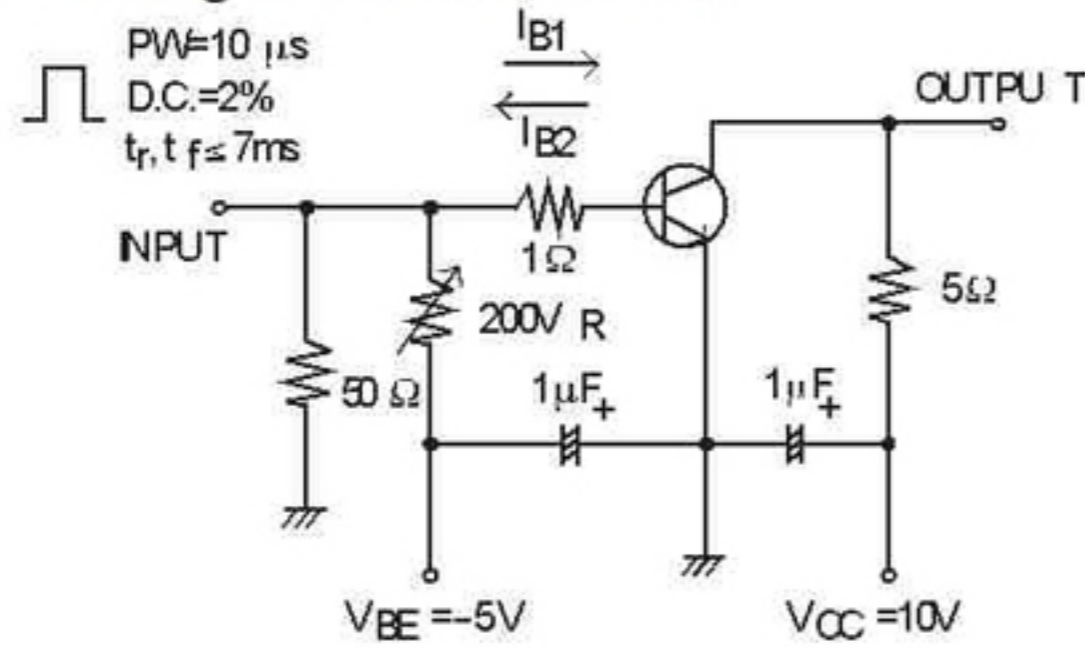

$$I_C = 10I_B, I_B = -10I_{B2} = 2A$$

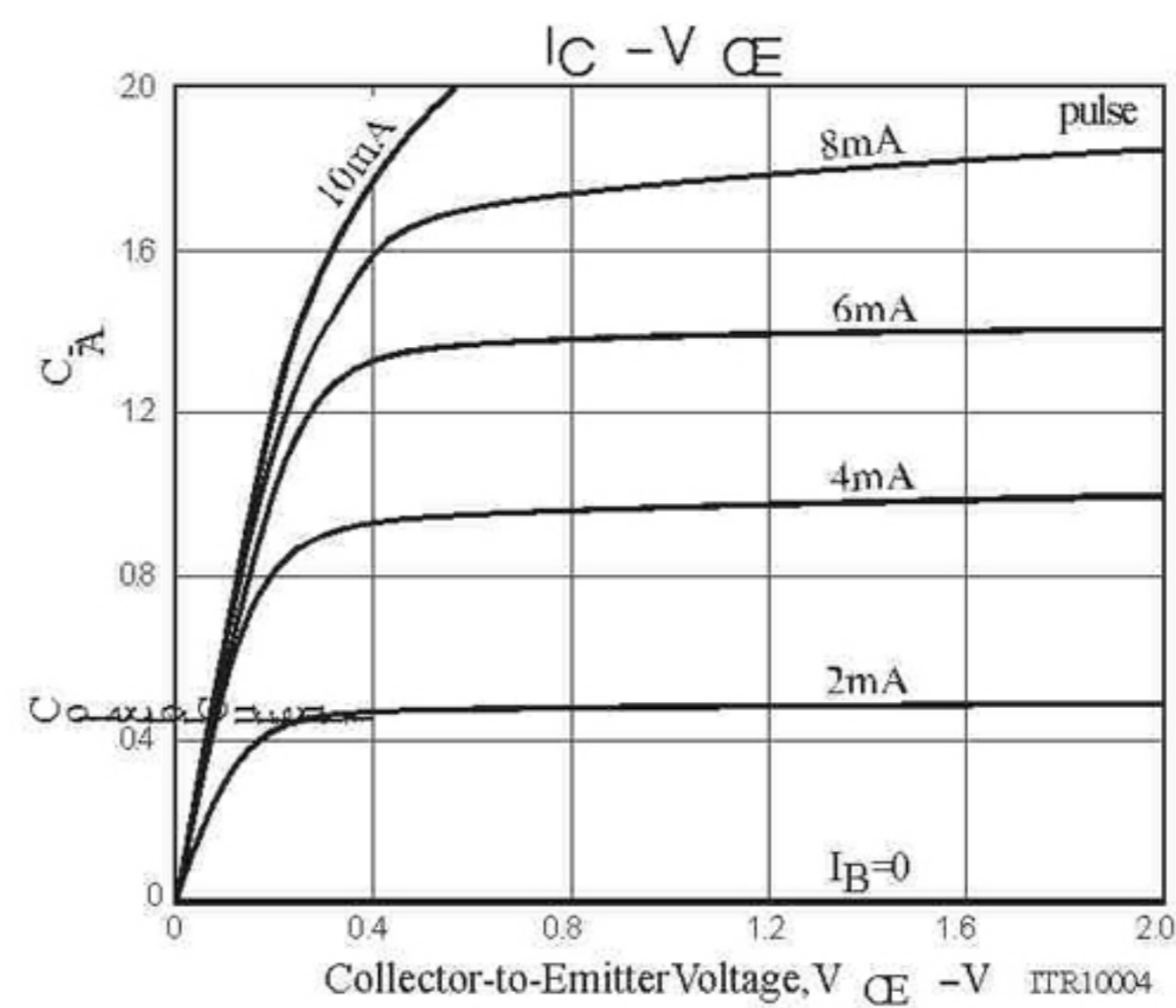
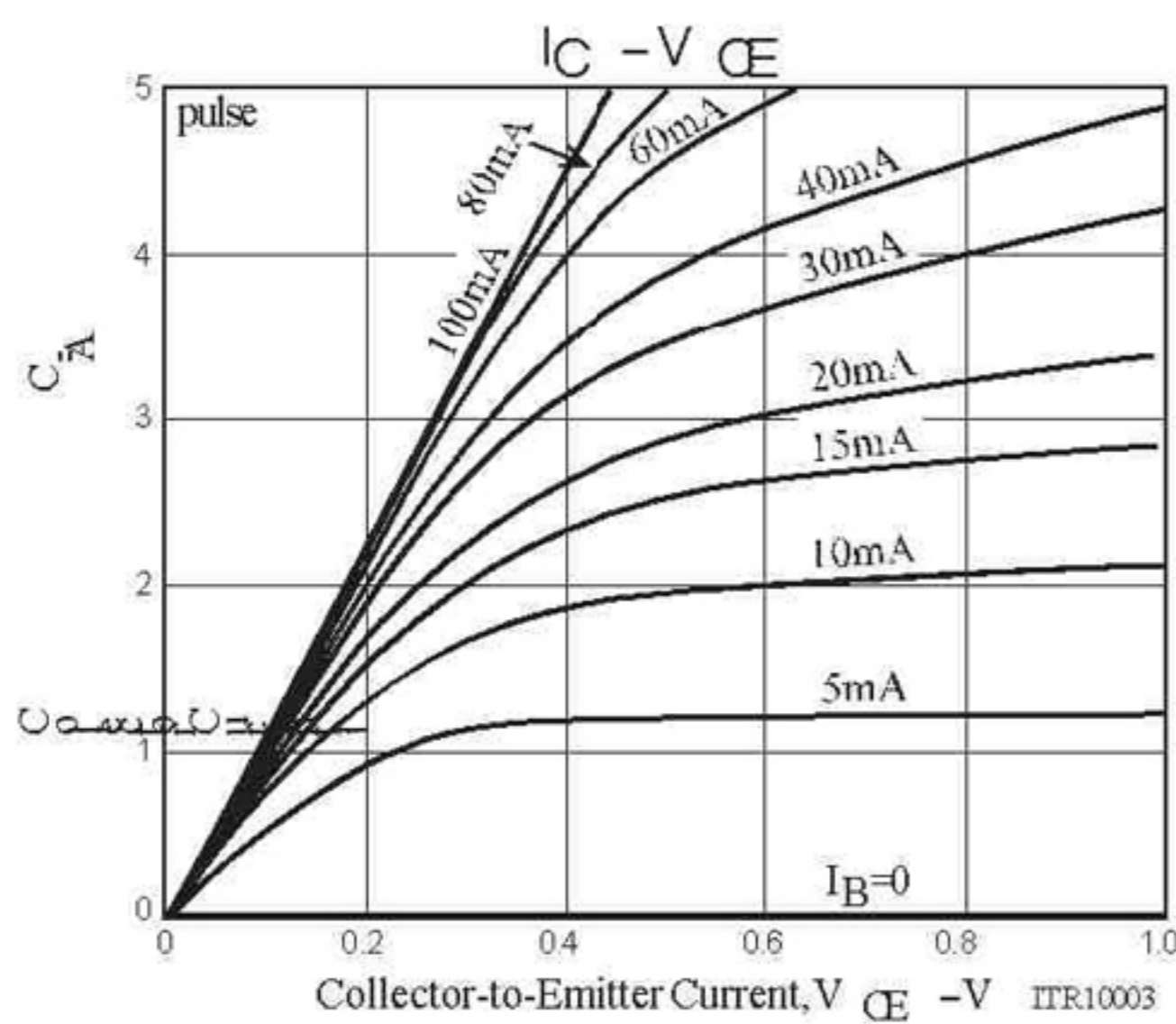

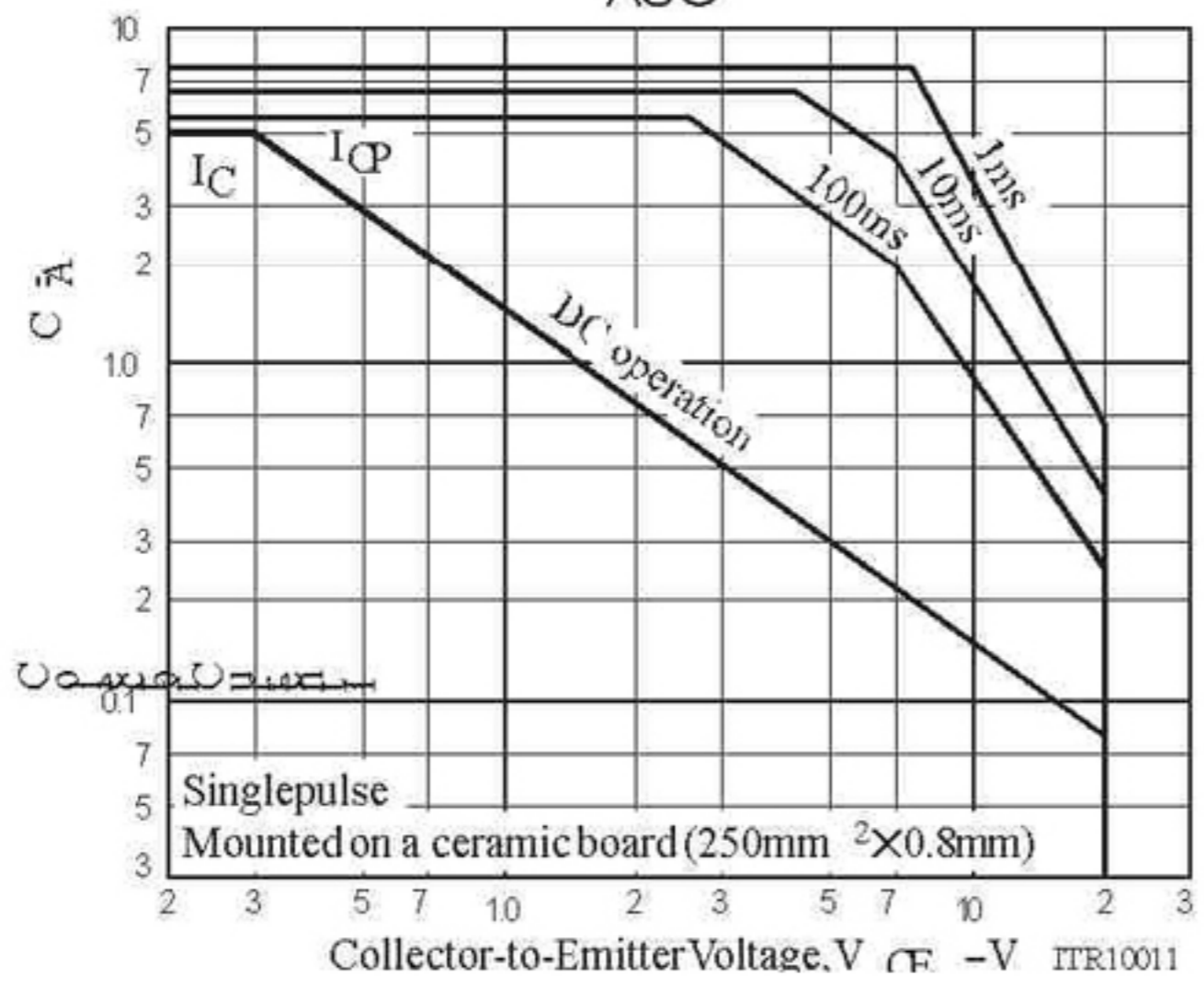
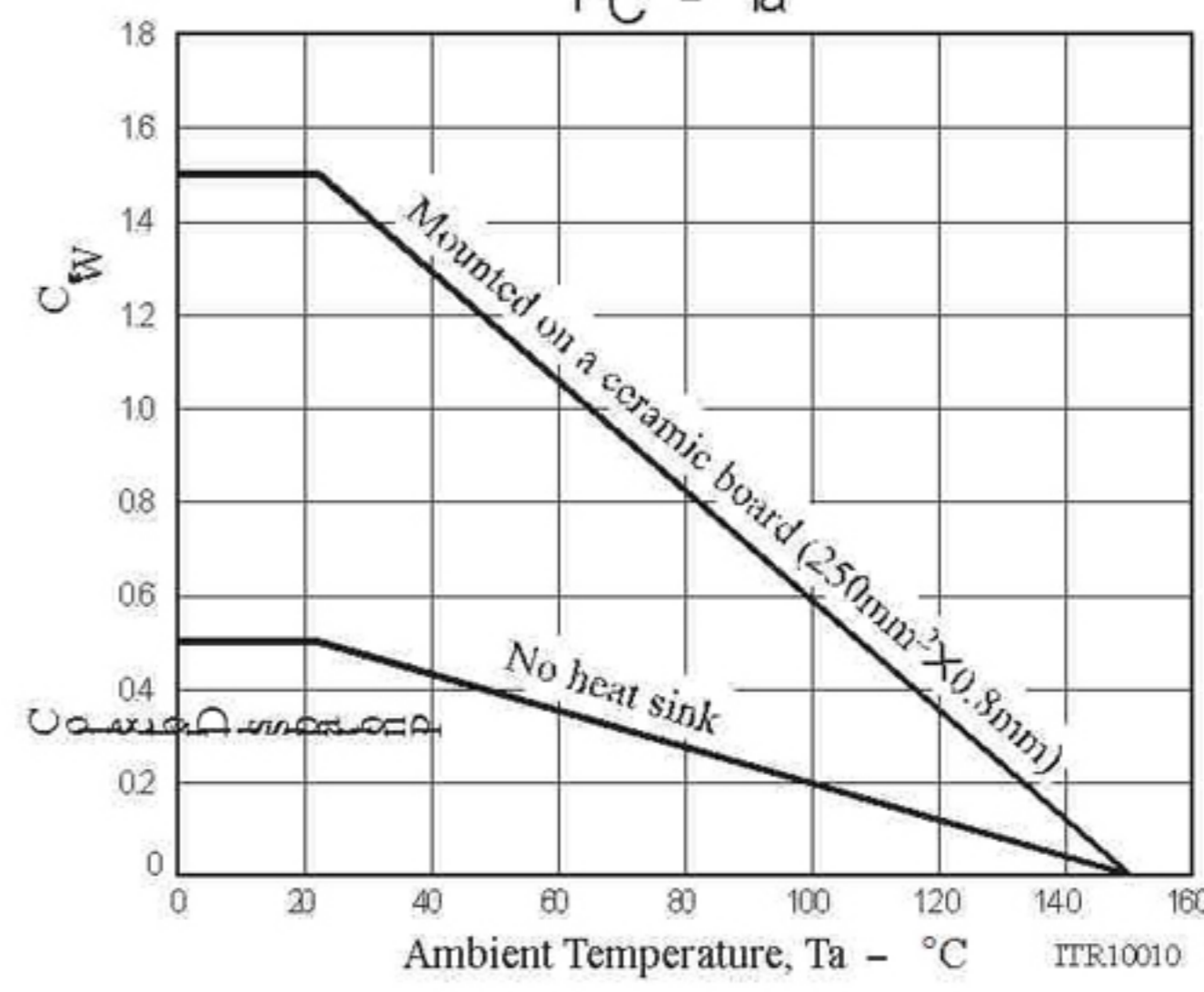
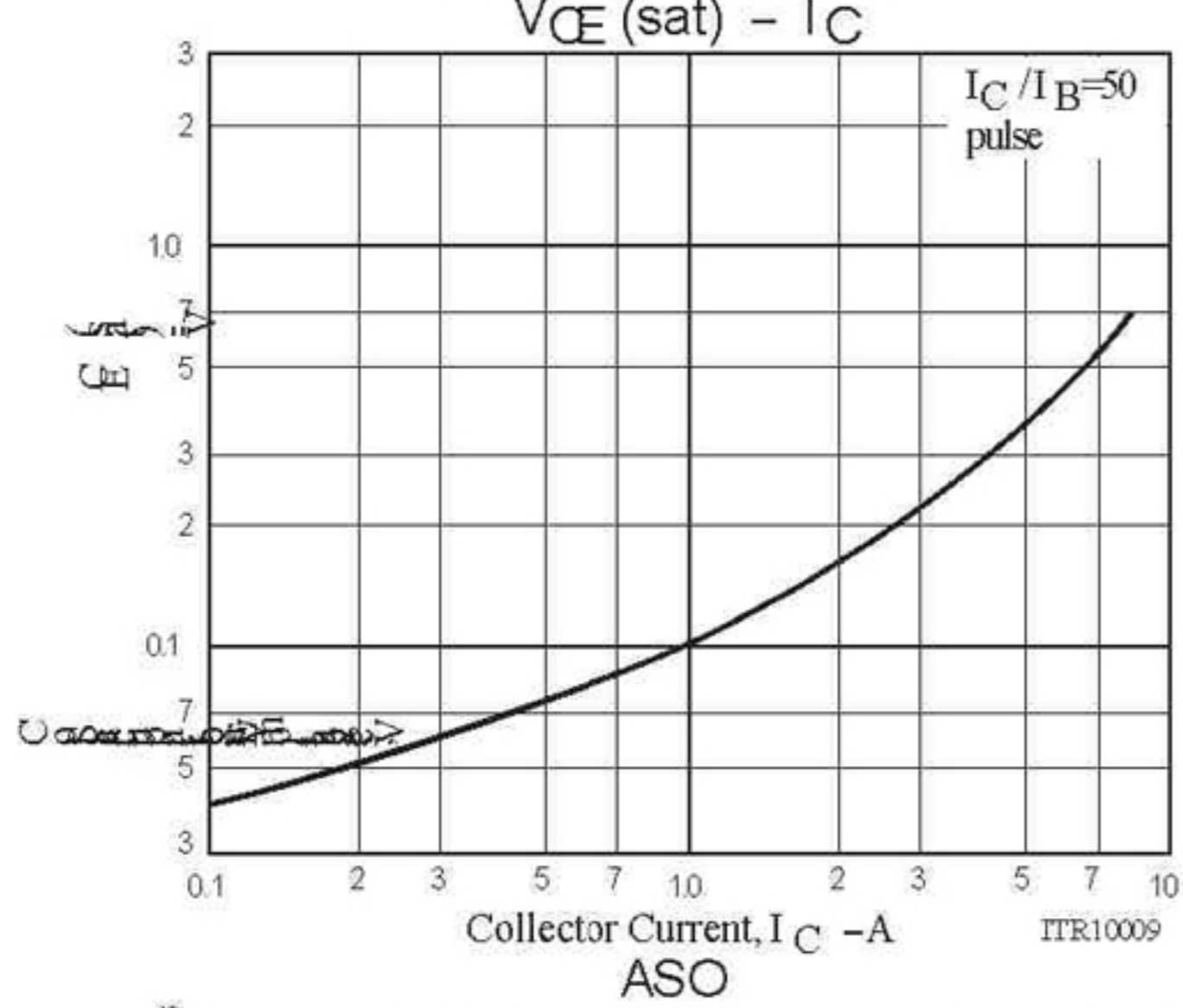
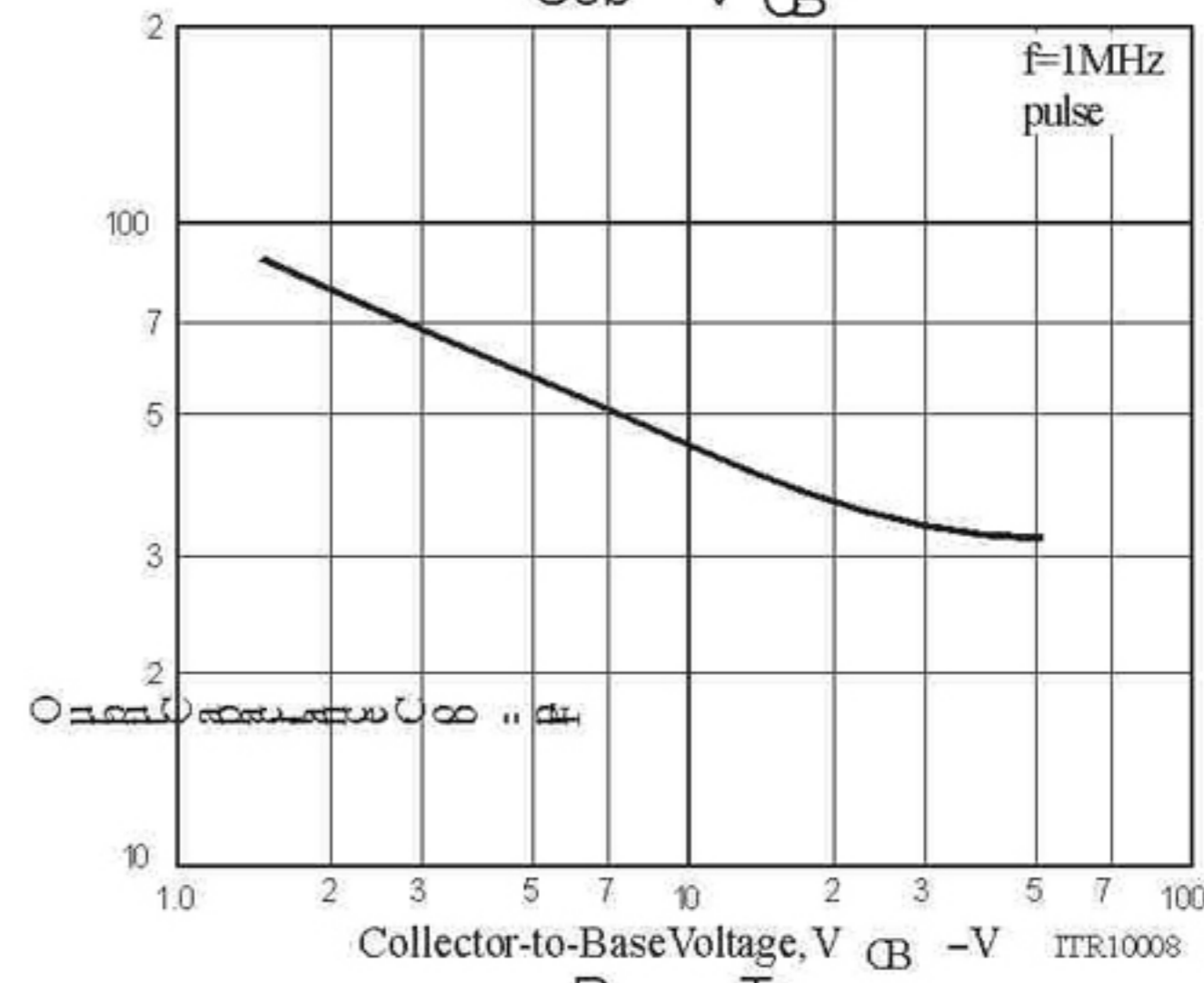
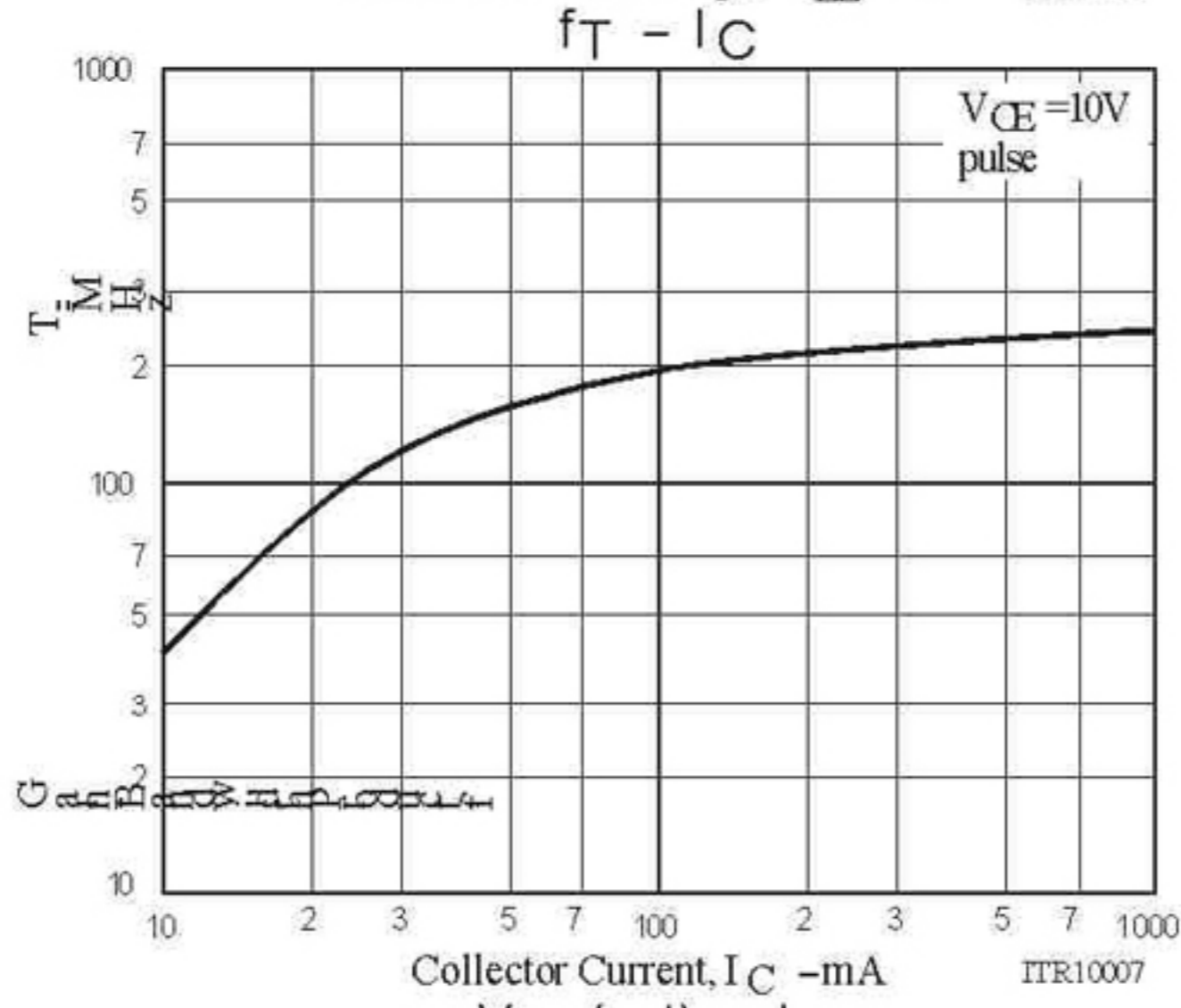
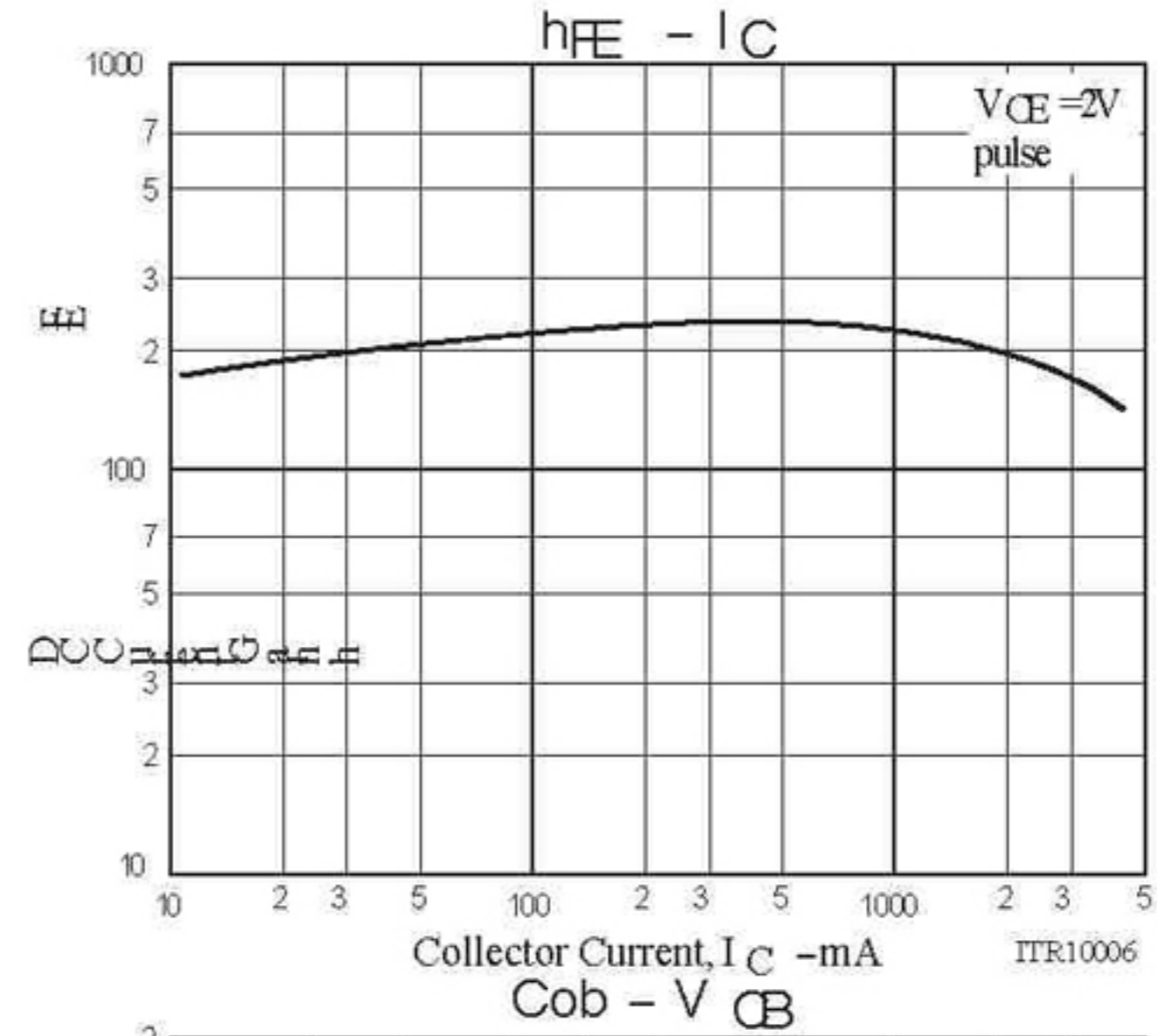
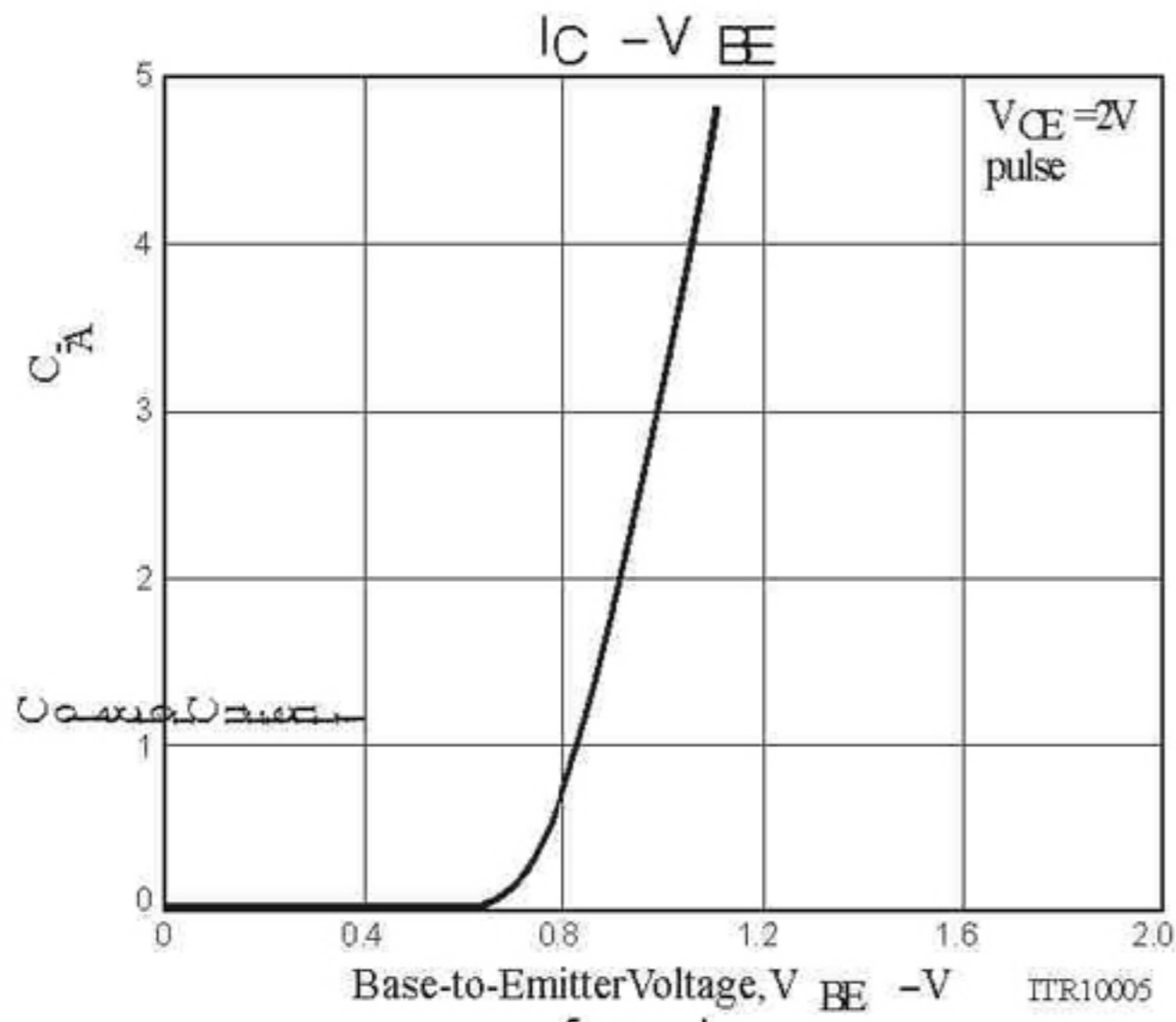

单击下面可查看定价，库存，交付和生命周期等信息

[>>SHIKUES\(时科\)](#)