

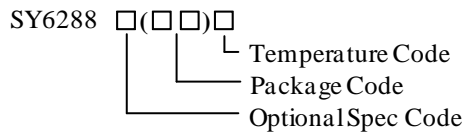

### General Description

The SY6288F1/F2 is an ultra-low  $R_{DS(ON)}$ , 3A Low Loss Power Distribution switch with current limit to protect the power source from over current and short circuit conditions. It incorporates over temperature protection and reverse blocking function.

### Ordering Information



Ordering Number	Package type	UL certified
SY6288F1ABC	SOT23-6	YES
SY6288F2ABC	SOT23-6	YES

### Features

- Input Voltage: 2.5V to 5.5V
- Extremely Low Power Path Resistance: 45mΩ (typ.)
- 3A Load Current Capability
- Two Enable Polarities:
  - SY6288F1ABC: Active High
  - SY6288F2ABC: Active Low
- Over Temperature Shutdown and Automatic Retry
- Reverse Blocking (No Body Diode)
- Fault Flag (OCB) Output for Over Current and Fault Conditions
- Programmable Current Limitation
- At Shutdown, OUT Can be Forced Higher than IN
- Built-in Soft-start
- Compact Package Minimizes the Board Space: SOT23-6
- RoHS Compliant and Halogen Free
- UL Certification NO. E491480
- CB Certification by IEC 62368-1

### Applications

- USB 3.1 Application
- USB 3G Datacard
- USB Dongle
- MiniPCI Accessories
- USB Charger
- Public Place Multi-USB Charger

### Typical Application Circuit

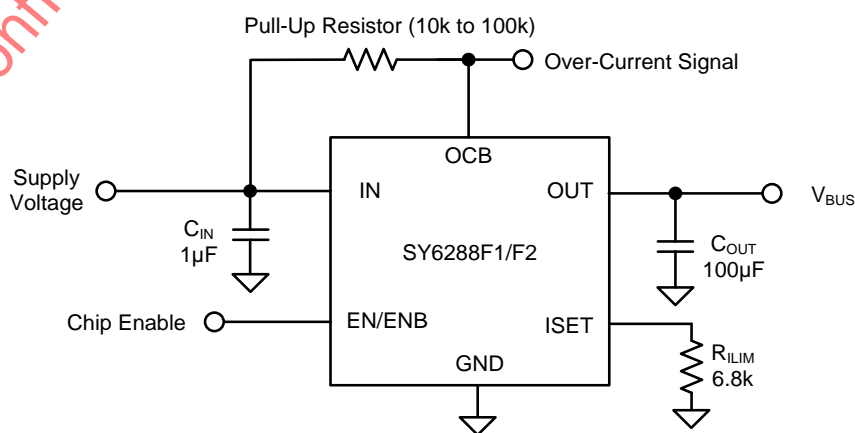

Note: If 1uF input cap will lead to large  $V_{in}$  voltage spike, it is strongly recommended to add additional 10uF ceramic cap.

Figure 1. Schematic Diagram

**Pinout (Top View)**

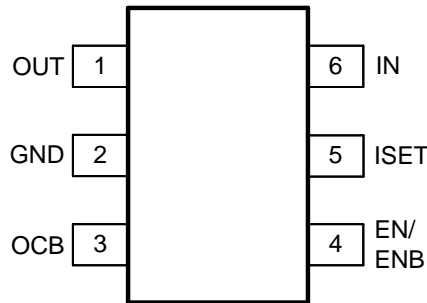

Part Number	Package type	Top Mark <sup>Ⓞ</sup>
SY6288F1ABC	SOT23-6	<b>Kxyz</b>
SY6288F2ABC	SOT23-6	<b>Nxyz</b>

Note ①: x=year code, y=week code, z= lot number code.

Pin Name	Pin number	Pin Description
	SOT23-6	
OUT	1	Output pin, decoupled with a 10μF capacitor to GND.
GND	2	Ground pin.
OCB	3	Open Drain Fault Flag.
EN/ENB	4	ON/OFF control. Do not leave it floating. EN: Active high; ENB: Active low.
ISET	5	Current limit programming pin. Connect a resistor R <sub>SET</sub> from this pin to ground to program the current limit: I <sub>LIM</sub> (A)=6800/R <sub>SET</sub> (Ω)
IN	6	Input pin, decoupled with a 10μF capacitor to GND

Silergy Confidential-For Internal Use Only

### Block Diagram

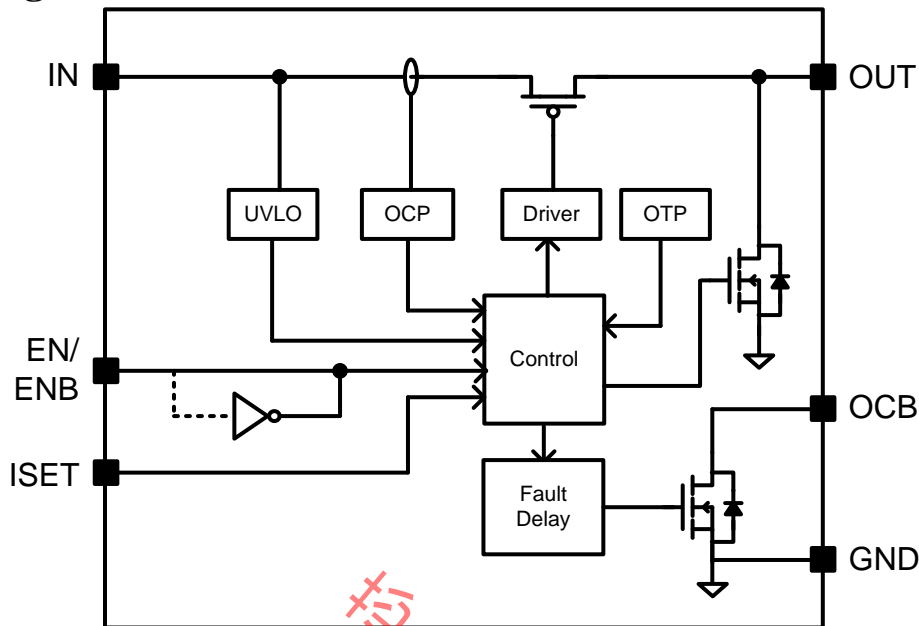

### Absolute Maximum Ratings (Note 1)

All pins-----	6V
Power Dissipation, P <sub>D</sub> @ T <sub>A</sub> = 25°C SOT23-6 -----	1.7W
Package Thermal Resistance (Note 2)	
θ <sub>JA</sub> -----	61°C/W
θ <sub>JC</sub> -----	22°C/W
Junction Temperature-----	150°C
Lead Temperature (Soldering, 10 sec.) -----	260°C
Storage Temperature Range -----	-65°C to 150°C

### Recommended Operating Conditions (Note 3)

IN-----	2.5V to 5.5V
All other pins -----	0V to 5.5V
Junction Temperature Range -----	-40°C to 125°C
Ambient Temperature Range -----	-40°C to 85°C

## Electrical Characteristics

( $V_{IN} = 5V$ ,  $C_{OUT} = 10\mu F$ ,  $T_A = 25^\circ C$  unless otherwise specified)

Parameter	Symbol	Test Conditions	Min	Typ	Max	Unit
Input Voltage Range	$V_{IN}$		2.5		5.5	V
Shutdown Input Current	$I_{SHDN}$	Open load, switch off		0.1	1	$\mu A$
		Output grounded, switch off		0.1	1	$\mu A$
Quiescent Supply Current	$I_Q$	Open load, switch on		35		$\mu A$
FET $R_{DS(ON)}$	$R_{DS(ON)}$	$V_{IN} = 5V$ , $I_{OUT} = 0.5A$	38	45	50	m $\Omega$
Current Limit	$I_{LIM}$	$R_{SET} = 6.8k$	0.75	1	1.25	A
Fold back Current	$I_{FBC}$	$V_{IN} > 3.5V$ , $V_{OUT} < 1V$		0.6	0.75	A
Programmable Current Limit Range	$I_{LIM\_RANGE}$		0.4		4	A
EN/ENB Threshold	Logic-Low Voltage	$V_{IL}$			0.5	V
	Logic-High Voltage	$V_{IH}$	1.0			V
IN UVLO Threshold	$V_{IN,UVLO}$				2.45	V
IN UVLO Hysteresis	$V_{IN,HYS}$			0.1		V
Rise Time	$t_{RISE}$	$V_{IN} = 3.3V$ , $R_L = 3\ \Omega$ , $C_L = 1\mu F$	1	1.5	2	ms
		$V_{IN} = 5.0V$ , $R_L = 5\ \Omega$ , $C_L = 1\mu F$	1.6	2.3	3	ms
OCB Low Resistance	$R_{OCB}$			65		$\Omega$
OCB Delay Time	$t_{OCB\_Delay}$			10		ms
OUT Shutdown Discharge Resistance	$R_{DIS}$	SY6288F1/F2	50	63	76	$\Omega$
Thermal Shutdown Temperature	$T_{SD}$			150		$^\circ C$
Thermal Shutdown Hysteresis	$T_{HYS}$			20		$^\circ C$

**Note 1:** Stresses beyond “Absolute Maximum Ratings” may cause permanent damage to the device. These are for stress ratings. Functional operation of the device at these or any other conditions beyond those indicated in the operational sections of the specifications is not implied. Exposure to absolute maximum rating conditions for extended periods may affect device reliability.

**Note 2:**  $\theta_{JA}$  is measured in the natural convection at  $T_A = 25^\circ C$  on a Silergy test board. Pin 2 of SOT23 package is the case position for  $\theta_{JC}$  measurement.

**Note 3:** The device is not guaranteed to function outside its operating conditions.

**SOT23-6 Package outline & PCB layout design**

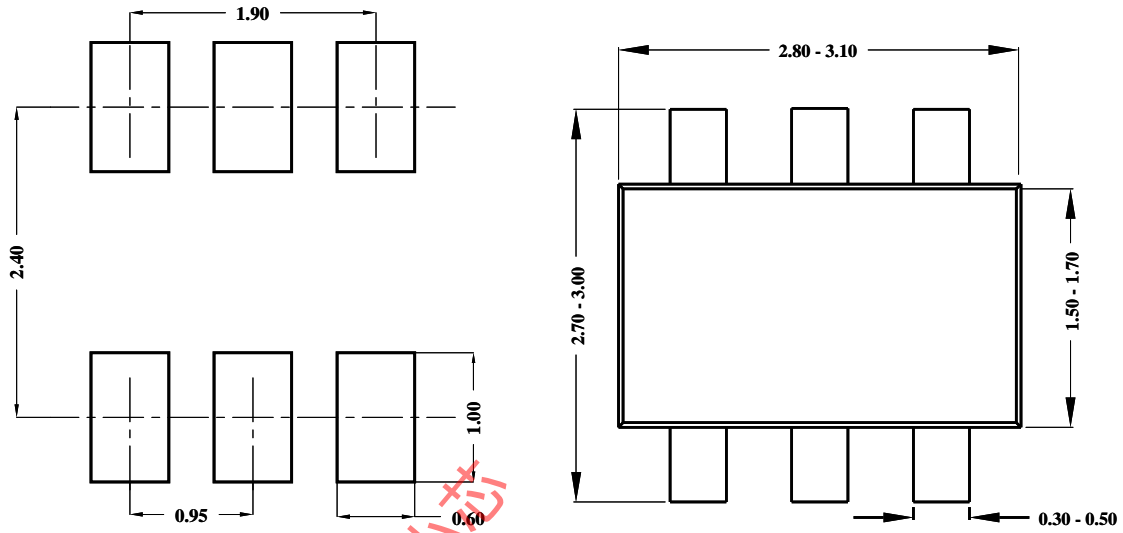

**Recommended Pad Layout**

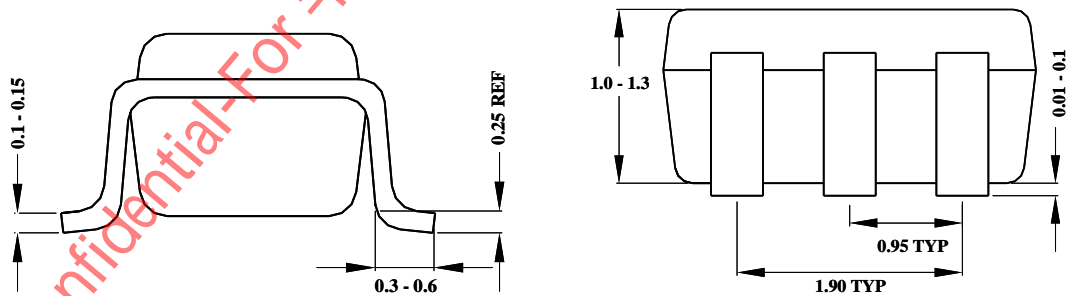

**Notes:** All dimensions are in millimeters.  
All dimensions don't include mold flash & metal burr.

## Taping & Reel Specification

### 1. Taping orientation

SOT23-6

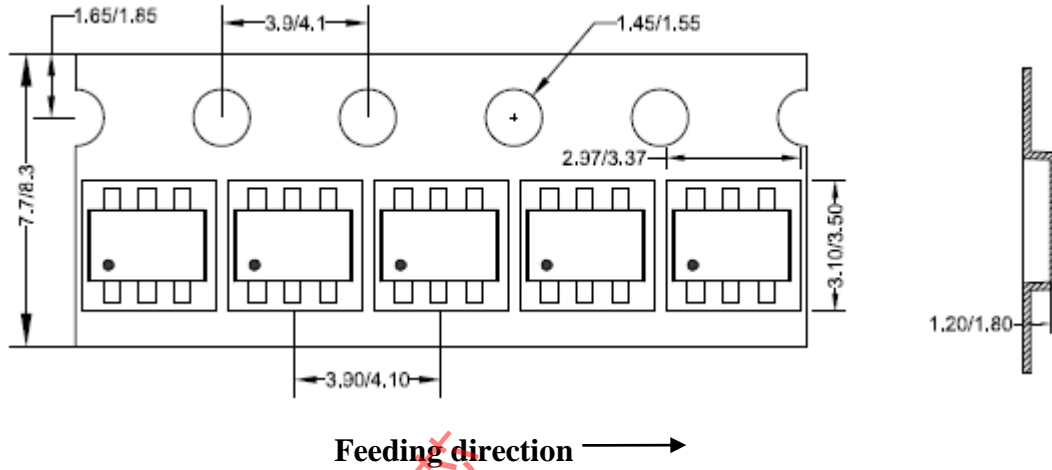

### 2. Carrier Tape & Reel specification for packages

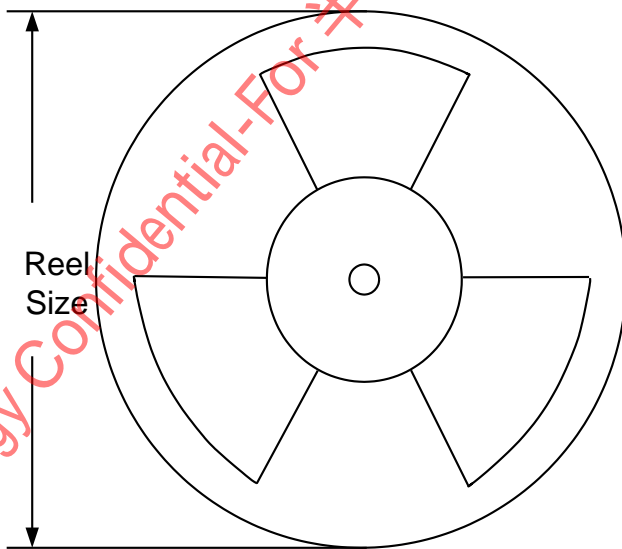

Package types	Tape width (mm)	Pocket pitch(mm)	Reel size (Inch)	Trailer length(mm)	Leader length (mm)	Qty per reel
SOT23-6	8	4	7"	280	160	3000

### 3. Others: NA

单击下面可查看定价，库存，交付和生命周期等信息

[>>SILERGY\(矽力杰\)](#)