

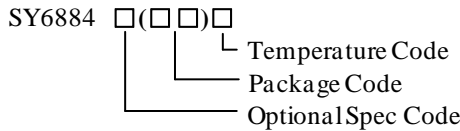

General Description

SY6884 is a programmable over voltage protection switch with 5A current capability to prevent damage to the downstream system with low voltage rating. It achieves wide input voltage range from 2.5V_{DC} to 25V_{DC}. Extremely low power path on resistance R_{PWPT} helps to reduce power loss during the normal operation. It integrates the over-temperature protection and auto-recovery with hysteresis to protect against over current events. This IC along with small CSP (0.89mm×1.43mm) footprint provides small PCB area application.

Ordering Information



Ordering Number	Package Type	Note
SY6884PYC	CSP0.89×1.43-6	

Features

- V_{IN}=2.5V to 25V, Absolute Maximum V_{IN}=28V
- Extremely Low Power Path on Resistance R_{PWPT}: 30mΩ Typ.
- Fast OVP Response Time: 100 ns.
- Auto-enabled Switch with 15ms Debounce Time
- Programmable Over Voltage Threshold From +4V to +20V
- Internal Soft-start to Prevent Inrush Current
- Thermal Shutdown Protection & Auto Recovery
- Short Circuit Protection
- Compact Package: CSP 0.89×1.43-6

Applications

- Smart Phone
- Tablet PCs
- Mobile Device

Typical Applications

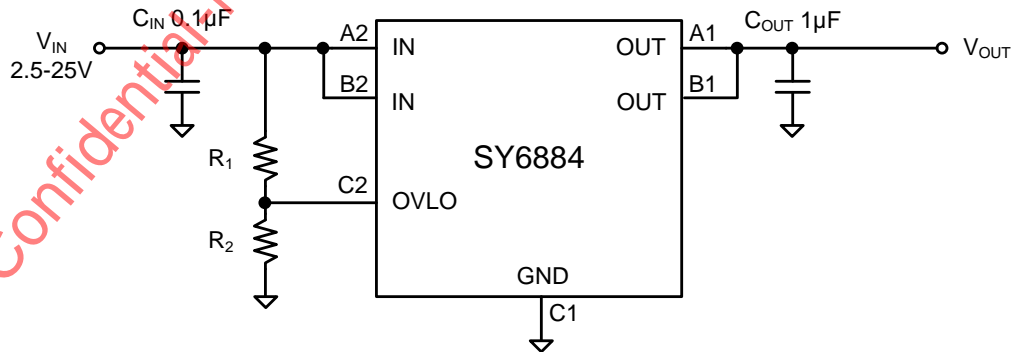
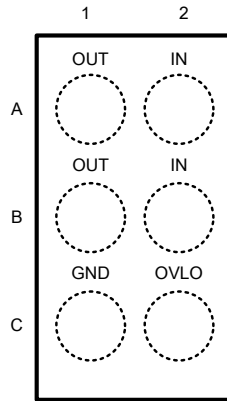

Figure1. Schematic Diagram

Pinout (top view)



(CSP0.89×1.43-6)

Top Mark: **cExyz**, (Device code: cE; **x=year code**, **y=week code**, **z=lot number code**)

Pin Name	Pin Number	Pin Description
IN	A2, B2	Power input pin. Connect IN pins together. Decouple high frequency noise by connecting at least a 0.1μF MLCC to ground.
OUT	A1, B1	Output voltage pin. Source side of the internal FET. Connect OUT pins together for normal operation.
OVLO	C2	External OVLO program pin. Connect resistor divider to this pin to program the OVLO threshold. Make sure V_{OVLO} is higher than external OVLO select threshold 0.28V; otherwise the internal default OVP threshold 6.75V (typ.) is active. Pull down this pin to ground to disable external program function.
GND	C1	Power ground pin.

Block Diagram

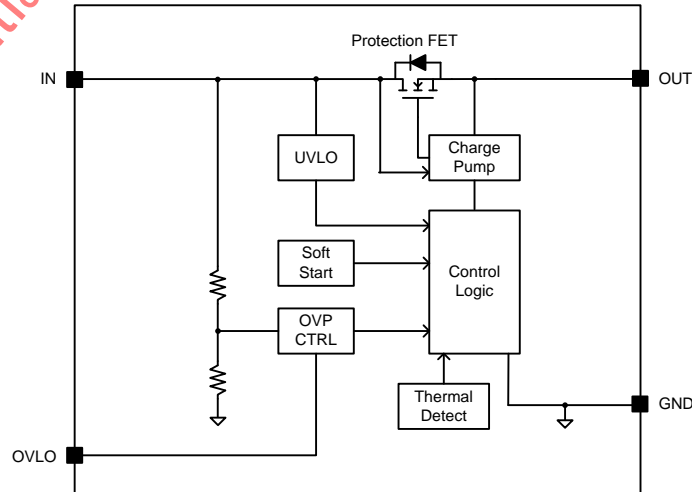

Figure2. Block Diagram

Absolute Maximum Ratings (Note 1)

IN	-----	-0.3 to 28V
OUT	-----	-0.3 to IN + 0.3V
OVLO	-----	-0.3 to 28V
Continues IN, OUT Current	-----	5 A
Power Dissipation, P _D @ T _A = 25°C CSP	-----	1.1W
Package Thermal Resistance (Note 2)		
θ _{JA}	-----	91.1°C/W
θ _{JC}	-----	35.5°C/W
Junction Temperature Range	-----	150°C
Lead Temperature (Soldering, 10 sec.)	-----	260°C
Storage Temperature Range	-----	-65°C to 150°C

Recommended Operating Conditions (Note 3)

IN	-----	2.5 to 25V
OUT	-----	0 to 25V
OVLO	-----	0 to 25V
Junction Temperature Range	-----	-40°C to 125°C
Ambient Temperature Range	-----	-40°C to 85°C

Silergy Confidential-For 公司

Electrical Characteristics

($V_{IN} = 2.5V$ to $28V$, $C_{IN}=1\mu F$, $C_{OUT}=1\mu F$, $T_A = 25^\circ C$, unless otherwise specified.)

Parameter	Symbol	Test Conditions	Min	Typ	Max	Unit
Input Voltage Range	V_{IN}		2.5		25	V
Input UVLO Rising Threshold	V_{UVLO}				2.45	V
UVLO Hysteresis	V_{HYS}			0.15		V
Bias Current	I_{BIAS}	$V_{IN}=5V, V_{IN}<V_{IN_OVLO}$		110		μA
OVLO Input Leakage Current	I_{OVLO}	$V_{OVLO}=V_{OVLO_TH}$	-100		100	nA
Internal Default OVP threshold	V_{OV_INTL}	$V_{OVLO}=0V, V_{IN}$ rise from 5.5V to 7V	6.5	6.75	7.0	V
Internal Default OVP Hysteresis	V_{OV_HYS}	$V_{OVLO}=0V, V_{IN}$ fall from 7V to 5.5V		0.2		V
OVLO Preset Threshold	V_{OVLO_TH}	$V_{IN}=5V, V_{OVLO}$ rise from 1V to 1.4V	1.14	1.20	1.26	V
External OVLO Select Threshold	V_{OVLO_SEL}	$V_{IN}=8V, V_{OVLO}$ fall from 0.4V to 0V		0.2	0.28	V
Programmable OVLO Range	V_{OV_EXTNL}		4		20	V
On Resistance of Power Path	R_{PWPT}	$V_{IN}=5V, I_{OUT}=500mA$, from IN to OUT		30	39	m Ω
Debounce Time	t_{DEB}	Time from $2.5V < V_{IN} < V_{IN_OVLO}$ to $V_{OUT}=10\%$ of V_{IN}		15		ms
Switch Turn-On Time	t_{ON}	$V_{IN}=5V, R_L=100, C_{OUT}=100\mu F$; $V_{OUT}=10\%$ of V_{IN} to 90% of V_{IN}		245		μs
Switch Turn-Off Time	t_{OFF}	$V_{IN} > V_{IN_OVLO}$ to V_{OUT} stop rising		100		ns
Thermal Shutdown Temperature	T_{SD}			150		$^\circ C$
Thermal Shutdown Hysteresis	T_{HYS}			20		$^\circ C$

Note 1: Stresses beyond the “Absolute Maximum Ratings” may cause permanent damage to the device. These are stress ratings only. Functional operation of the device at these or any other conditions beyond those indicated in the operational sections of the specification is not implied. Exposure to absolute maximum rating conditions for extended periods may affect device reliability.

Note 2: θ_{JA} is measured in the natural convection at $T_A = 25^\circ C$ on a Silergy’s test board.

Note 3: The device is not guaranteed to function outside its operating conditions.

Note 4: $R1=1M\Omega$ is a good starting value for minimum current consumption. Since V_{IN_OVLO} , V_{OVLO_TH} , and $R1$ are known, $R2$ can be calculated from the following formula:

$$V_{IN_OVLO} = V_{OVLO_TH} \times (1 + R1/R2) = 1.2V \times (1 + R1/R2)$$

CSP0.89*1.43-6 Package Outline Drawing

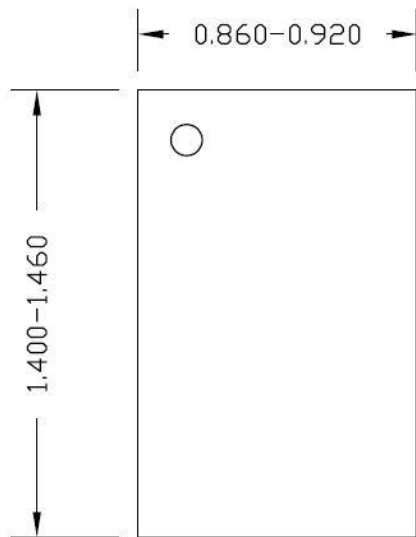

Top view

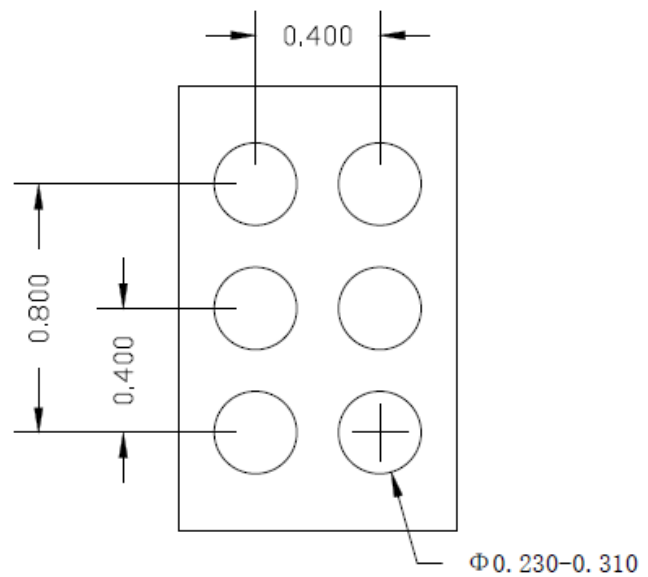

Bottom view

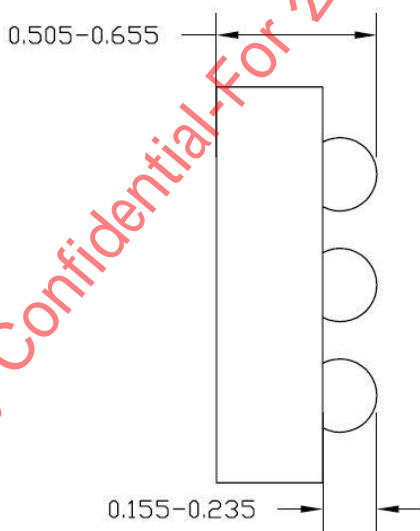

Side view

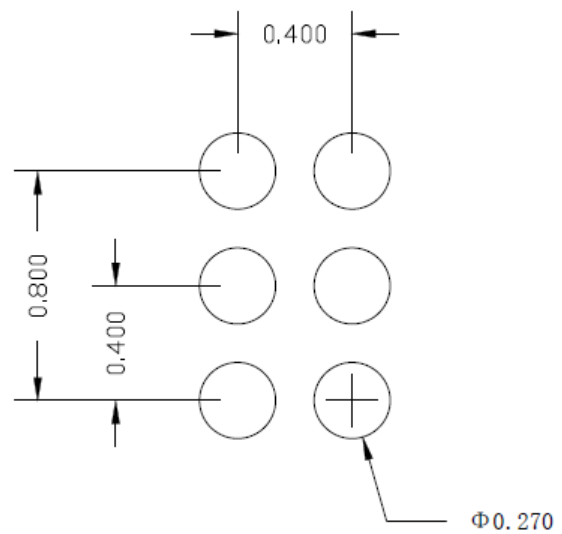

Recommended PCB layout
(Reference only)

Notes: All dimension in millimeter and exclude mold flash & metal burr.

Taping & Reel Specification

1. CSP0.89×1.43 Taping Orientation

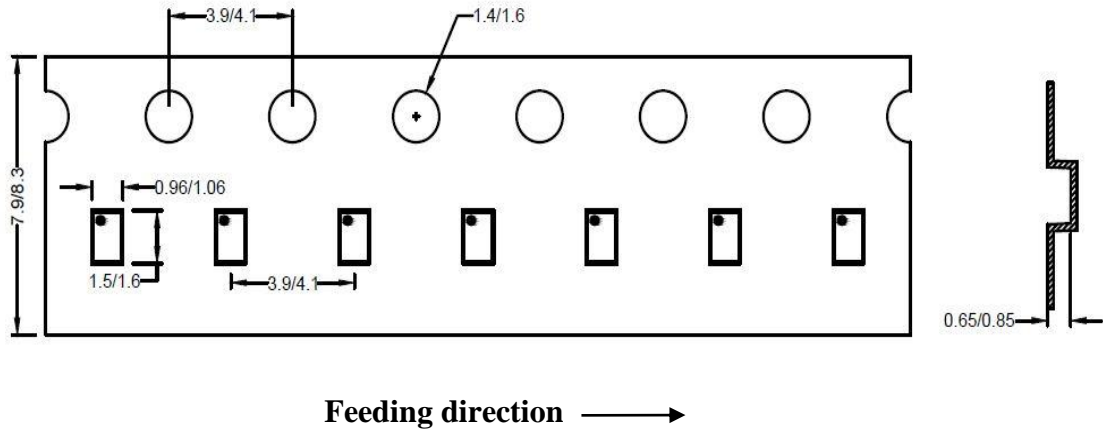

2. Carrier Tape & Reel specification for packages

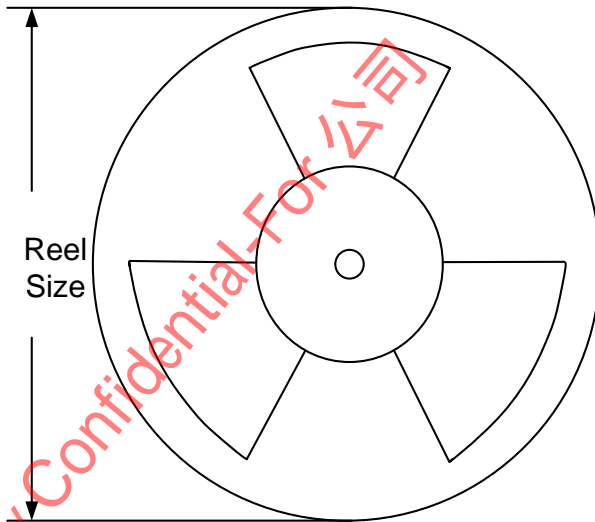

Package type	Tape width (mm)	Pocket pitch(mm)	Reel size (Inch)	Trailer length(mm)	Leader length (mm)	Qty per reel
CSP0.89×1.43	8	4	7"	400	160	3000

3. Others: NA

单击下面可查看定价，库存，交付和生命周期等信息

[>>SILERGY\(矽力杰\)](#)