

General Description

The SM80592E is a high efficiency 1.5MHz synchronous step down DC/DC regulator capable of delivering up to 2A output current. It can operate over a wide input voltage range from 2.5V to 5.5V and integrate main switch and synchronous switch with very low $R_{DS(ON)}$ to minimize the conduction loss.

The low output voltage ripple, the small external inductor and the capacitor sizes are achieved with 1.5MHz switching frequency.

Ordering Information

SM80592 □(□□□)

Package Code

Optional Spec Code

| Ordering Number | Package type | Note |
|-----------------|--------------|------|
| SM80592EIHD | DFN1.3×0.9-6 | -- |

Features

- 2.5V to 5.5V Input Voltage Range
- Low $R_{DS(ON)}$ for Internal Switches (Top/Bottom) 125mΩ /75mΩ
- High Switching Frequency 1.5MHz Minimizes the External Components
- Internal Soft-start Limits the Inrush Current
- 100% Dropout Operation
- Forced PWM Operation
- Power Good Indicator
- Hic-cup for Short Circuit Protection
- Output Auto Discharge Function
- RoHS Compliant and Halogen Free
- Compact Package: DFN1.3×0.9-6

Applications

- Set Top Box
- USB Dongle
- Media Player
- Smart Phone

Typical Applications

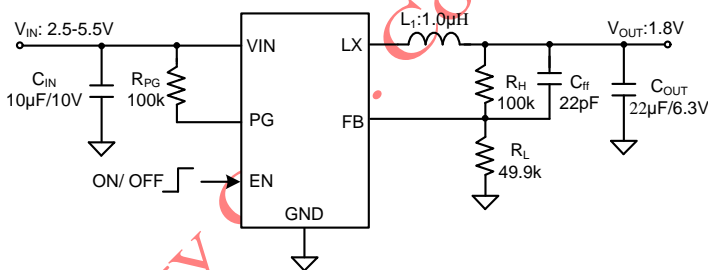

Inductor and C_{OUT} Selection Table

| V_{OUT} [V] | L [µH] | C_{OUT} [µF] | | | |
|---------------|--------|----------------|----|----|------|
| | | 4.7 | 10 | 22 | 22×2 |
| 1.2 | 1.0 | | ✓ | ☆ | ✓ |
| | 1.5 | | ✓ | ✓ | ✓ |
| 1.8/3.3 | 1.0 | | | ☆ | ✓ |
| | 1.5 | | | ✓ | ✓ |

Note: '☆' means recommended for most applications.

Figure1. Schematic Diagram

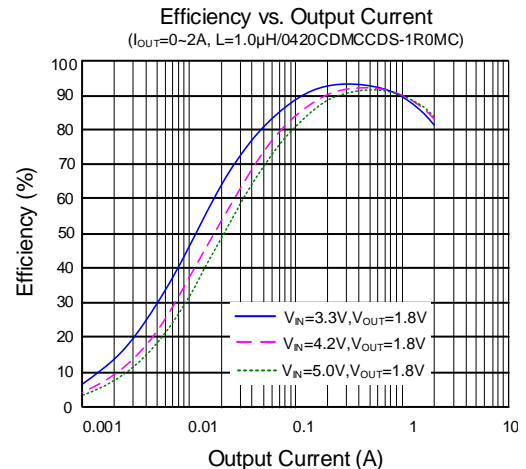
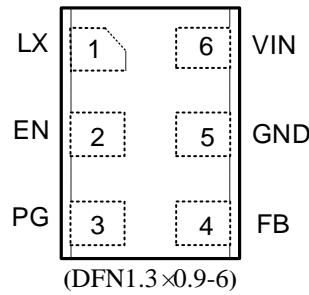

Figure2. Efficiency vs. Output Current

Pinout (Top View)



Top Mark: N2xyz (device code: N2, x=year code, y=week code, z=lot number code)

| Pin Name | Pin Number | Pin Description |
|----------|------------|---|
| LX | 1 | Inductor pin. Connect this pin to the switching node of the inductor. |
| EN | 2 | Enable control. Pull high to turn on. Do not leave it floating. |
| PG | 3 | Power good indicator. Power good indicator (open drain output). Low if the output < 90% or the output >120% of regulation voltage; High otherwise. Connect a pull-up resistor to the input. |
| FB | 4 | Output feedback pin. Connect this pin to the center point of the output resistor divider (as shown in Figure 1) to program the output voltage: $V_{OUT}=0.6 \times (1+R_H/R_L)$. |
| GND | 5 | Ground pin. |
| VIN | 6 | Input pin. Decouple this pin to the GND pin with at least a 10 μ F ceramic capacitor. |

Function Block

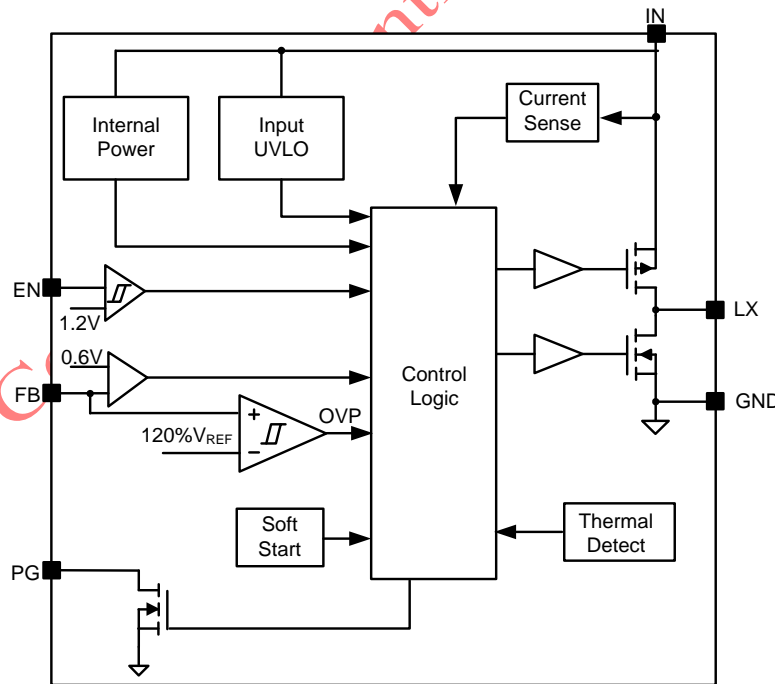

Figure3. Block Diagram



Absolute Maximum Ratings (Note 1)

| | | |
|---|-------|---|
| Supply Input Voltage | ----- | -0.3V to 6.0V |
| FB, EN, PG Voltage | ----- | -0.3V to $V_{IN}+0.6V$ |
| LX Voltage | ----- | -0.3V ^(*1) to 6.0V ^(*2) |
| Power Dissipation, P_D @ $T_A = 25\text{ }^\circ\text{C}$ | ----- | 1.1W |
| Package Thermal Resistance (Note 2) | | |
| θ_{JA} | ----- | 90 $^\circ\text{C/W}$ |
| θ_{JC} | ----- | 20 $^\circ\text{C/W}$ |
| Junction Temperature Range | ----- | -40 $^\circ\text{C}$ to 150 $^\circ\text{C}$ |
| Lead Temperature (Soldering, 10 sec.) | ----- | 260 $^\circ\text{C}$ |
| Storage Temperature Range | ----- | -65 $^\circ\text{C}$ to 150 $^\circ\text{C}$ |
| (*1) LX Voltage Tested Down to -3V<40ns | | |
| (*2) LX Voltage Tested Up to +7V<40ns | | |

Recommended Operating Conditions (Note 3)

| | | |
|----------------------------|-------|--|
| Supply Input Voltage | ----- | 2.5V to 5.5V |
| Junction Temperature Range | ----- | -40 $^\circ\text{C}$ to 125 $^\circ\text{C}$ |
| Ambient Temperature Range | ----- | -40 $^\circ\text{C}$ to 85 $^\circ\text{C}$ |

Silergy Corp. Confidential Prepared for PST



Electrical Characteristics

($V_{IN} = 5V$, $V_{OUT} = 1.8V$, $L = 1.0\mu H$, $C_{OUT} = 22\mu F$, $T_A = 25^\circ C$, unless otherwise specified)

| Parameter | Symbol | Test Conditions | Min | Typ | Max | Unit |
|---|----------------|------------------------------------|-------|------|-------|-------------|
| Input Voltage Range | V_{IN} | | 2.5 | | 5.5 | V |
| Input UVLO Threshold | V_{UVLO} | | | 2.45 | 2.5 | V |
| Input UVLO Hysteresis | V_{YST} | | | 150 | | mV |
| Shutdown Current | I_{SHDN} | $V_{EN}=0V$ | | 0.1 | 1 | μA |
| Feedback Reference Voltage | V_{REF} | $I_{OUT}=0A$, CCM | 0.591 | 0.6 | 0.609 | V |
| LX Node Discharge Resistance | R_{DIS} | | | 50 | | Ω |
| Top FET R_{ON} | $R_{DS(ON)1}$ | | | 125 | | m Ω |
| Bottom FET R_{ON} | $R_{DS(ON)2}$ | | | 75 | | m Ω |
| EN Input Voltage High | $V_{EN,H}$ | | 1.2 | | | V |
| EN Input Voltage Low | $V_{EN,L}$ | | | | 0.4 | V |
| PG Threshold for Under Voltage Detection | $V_{PG,UVP}$ | | | 90 | | % |
| PG Low Delay Time for Under Voltage Detection | $t_{UVP,DLY}$ | | | 15 | | μs |
| PG Threshold for Over Voltage Detection | $V_{PG,OVDP}$ | | | 120 | | % |
| PG Low Delay Time for Over Voltage Detection | $t_{OVP,DLY}$ | | | 15 | | μs |
| Min ON Time | $t_{ON,MIN}$ | | | 50 | | ns |
| Maximum Duty Cycle | D_{MAX} | | 100 | | | % |
| Turn On Delay Time | $t_{ON,DLY}$ | from EN high to LX start switching | | 0.25 | | ms |
| Soft-start Time | t_{SS} | V_{OUT} from 0% to 100% | | 0.75 | | ms |
| Switching Frequency | f_{SW} | $I_{OUT}=0A$, CCM | | 1.5 | | MHz |
| Top FET Current Limit | $I_{LMT, TOP}$ | | 3 | | | A |
| Bottom FET Reverse Current Limit | $I_{LMT, RVS}$ | | 0.55 | | 1.2 | A |
| Output Under Voltage Protection Threshold | V_{UVP} | | | 50 | | % V_{REF} |
| Output UVP Delay | $t_{UVP,DLY}$ | | | 10 | | μs |
| UVP Hiccup ON Time | $t_{UVP, ON}$ | | | 1.45 | | ms |
| UVP Hiccup OFF Time | $t_{UVP, OFF}$ | | | 1.45 | | ms |
| Thermal Shutdown Temperature | T_{SD} | | | 160 | | $^\circ C$ |
| Thermal Shutdown Hysteresis | T_{HYS} | | | 20 | | $^\circ C$ |

Note 1: Stresses beyond the “Absolute Maximum Ratings” may cause permanent damage to the device. These are stress ratings only. Functional operation of the device at these or any other conditions beyond those indicated in the operational sections of the specification is not implied. Exposure to absolute maximum rating conditions for extended periods may affect device reliability.

Note 2: θ_{JA} of SM80592E is measured in the natural convection at $T_A = 25^\circ C$ on a 2-oz two-layer Silergy evaluation board. Pin 1 is the case position for θ_{JC} measurement.

Note 3: The device is not guaranteed to function outside its operating conditions.



Typical Performance Characteristics

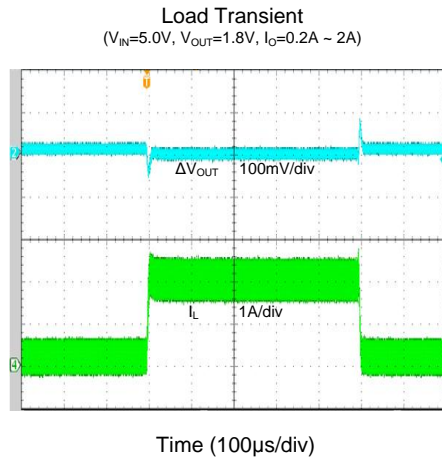
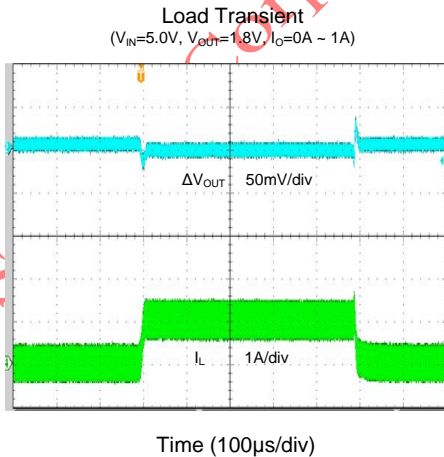
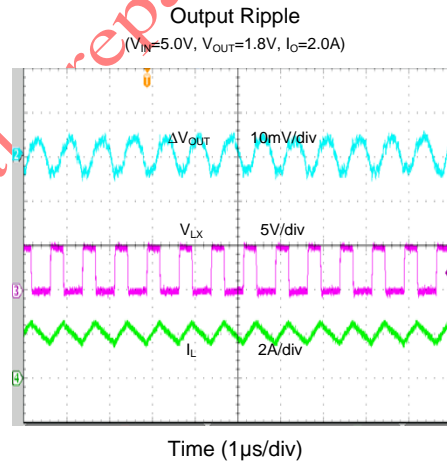
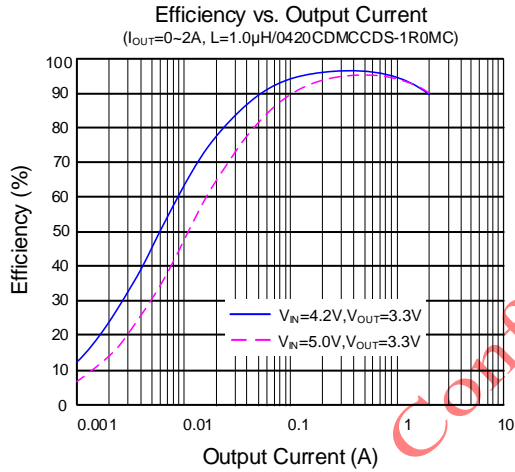
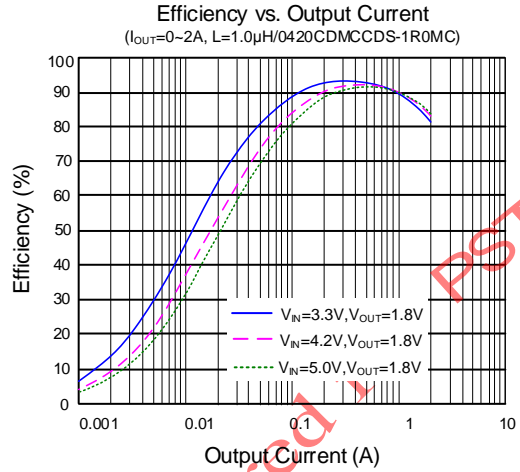
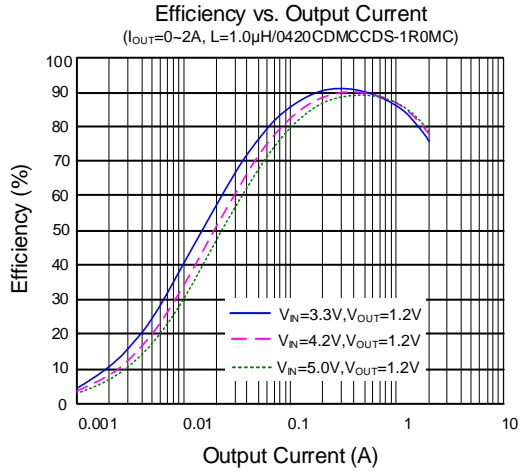

Startup from Enable
 ($V_{IN}=5.0V, V_{OUT}=1.8V, R_{LOAD}=0.9\Omega$)

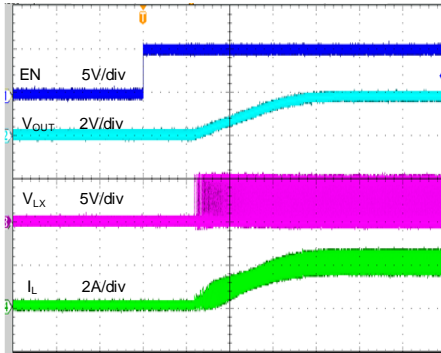

Time (200µs/div)

Shutdown from Enable
 ($V_{IN}=5.0V, V_{OUT}=1.8V, R_{LOAD}=0.9\Omega$)

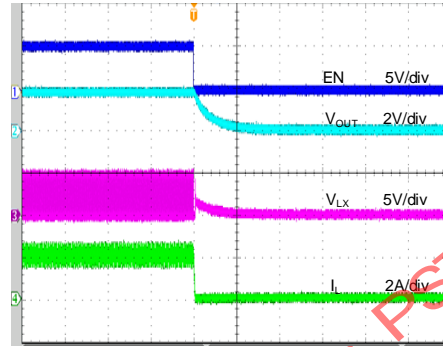

Time (40µs/div)

Short Circuit Protection
 ($V_{IN}=5.0V, V_{OUT}=1.8V, I_O=0A \sim$ Short)

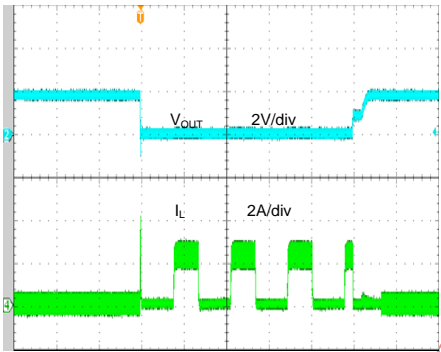

Time (2ms/div)

Short Circuit Protection
 ($V_{IN}=5.0V, V_{OUT}=1.8V, I_O=2A \sim$ Short)

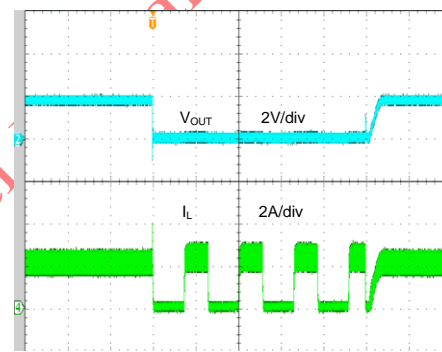

Time (2ms/div)

Silergy Corp. Confidential. Prepared for PST

Operation

The SM80592E is a high efficiency 1.5MHz synchronous step down DC/DC regulator capable of delivering up to 2A output current. It can operate over a wide input voltage range from 2.5V to 5.5V and integrate main switch and synchronous switch with very low $R_{DS(ON)}$ to minimize the conduction loss.

The low output voltage ripple, the small external inductor and the capacitor sizes are achieved with 1.5MHz switching frequency.

Applications Information

Because of the high integration in the SM80592E, the application circuit based on this regulator is rather simple. Only the input capacitor C_{IN} , the output capacitor C_{OUT} , the output inductor L and the feedback resistors (R_H and R_L) need to be selected for the targeted application specifications.

Feedback Resistor Dividers R_H and R_L

Choose R_H and R_L to program the proper output voltage. A value of between $1k\Omega$ and $1M\Omega$ is recommended for both resistors. If $R_L = 120k\Omega$ is chosen, then R_H can be calculated to be:

$$R_H = \frac{(V_{OUT} - 0.6V) \times R_L}{0.6V}$$

Input Capacitor C_{IN}

A typical X5R or better grade ceramic capacitor with 6.3V rating and greater than $10\mu F$ capacitance is recommended. To minimize the potential noise problem, this ceramic capacitor should be placed really close to the IN and GND pins. Care should be taken to minimize the loop area formed by C_{IN} and the IN/GND pins.

Output Inductor L

There are several considerations in choosing this inductor.

- 1) Choose the inductance to provide the desired ripple current. It is suggested to choose the ripple current to be about 40% of the maximum output current. The inductance is calculated as:

$$L = \frac{V_{OUT}(1 - V_{OUT}/V_{IN,MAX})}{f_{SW} \times I_{OUT,MAX} \times 40\%}$$

Where f_{SW} is the switching frequency and $I_{OUT,MAX}$ is the maximum load current.

- 2) For FCCM mode converter, in order to avoid the reverse current limit (0.55A min) being triggered

at open load condition, when choosing the inductance, the 1/2 inductor ripple current (ΔI) should be smaller than the reverse current limit threshold. Otherwise the output voltage will be charged to higher value. The 1/2 inductor ripple current is calculated as:

$$\frac{1}{2} \Delta I = \frac{V_{OUT}(V_{IN} - V_{OUT})}{2 \times L \times f_{SW} \times V_{IN}} \leq 0.55$$

Where f_{sw} is the switching frequency and 0.55 is the bottom FET reverse current limit. So the inductance can be calculated as:

$$L \geq \frac{V_{OUT}(V_{IN} - V_{OUT})}{1.1 \times V_{IN} \times f_{SW}}$$

- 3) The saturation current rating of the inductor must be selected to be greater than the peak inductor current under full load conditions.

$$I_{SAT,MIN} > I_{OUT,MAX} + \frac{V_{OUT}(1 - V_{OUT}/V_{IN,MAX})}{2 \times f_{SW} \times L}$$

- 4) The DCR of the inductor and the core loss at the switching frequency must be low enough to achieve the desired efficiency requirement. It is desirable to choose an inductor with $DCR < 50m\Omega$ to achieve a good overall efficiency.

Load Transient Considerations

The SM80592E regulator integrates the compensation components to achieve good stability and fast transient responses. In some applications, adding a 22pF ceramic capacitor in parallel with R_H may further speed up the load transient responses and is thus recommended for applications with large load transient step requirements.

Layout Design

The layout design of the SM80592E is relatively simple. For the best efficiency and to minimize noise problems, the following components should be placed close to the IC: C_{IN} , L , R_H and R_L .

- 1) It is desirable to maximize the PCB copper area connecting to the GND pin to achieve the best thermal and noise performance. If the board space allowed, a ground plane is highly desirable. Reasonable paths are suggested to be placed underneath the ground pad to enhance the soldering quality and thermal performance.



- 2) C_{IN} must be close to pins IN and GND. The loop area formed by C_{IN} and GND must be minimized.
- 3) The PCB copper area associated with the LX pin must be minimized to avoid the potential noise problem.
- 4) The components R_H and R_L and the trace connecting to the FB pin must NOT be adjacent to the LX net on the PCB layout to avoid the noise problem.

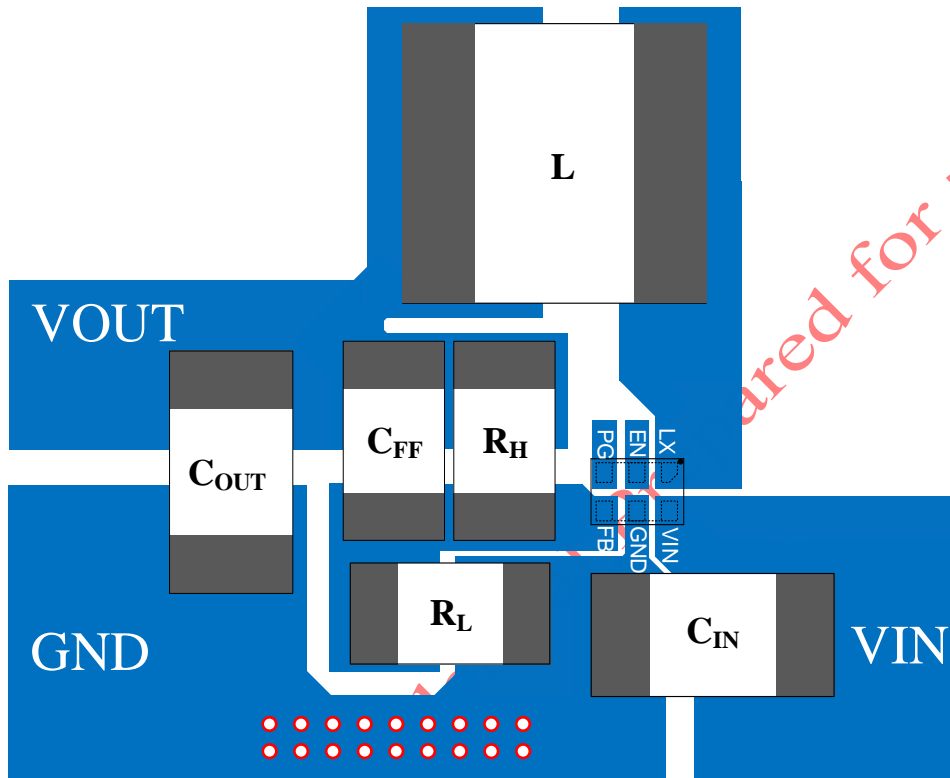
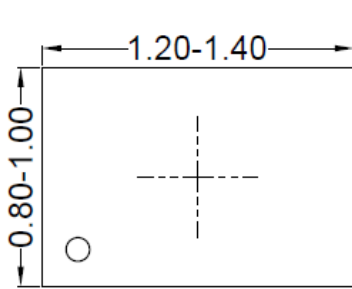
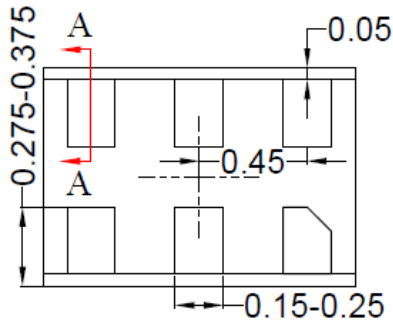

Figure4. PCB Layout Suggestion

DFN1.3×0.9-6 Package Outline Drawing



Top View



Bottom View

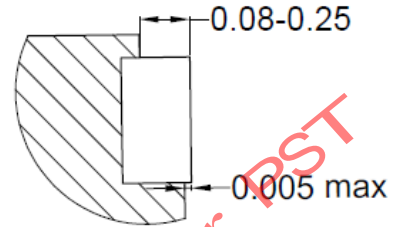

A-A

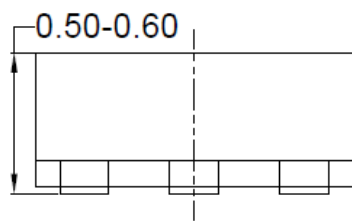

Front View

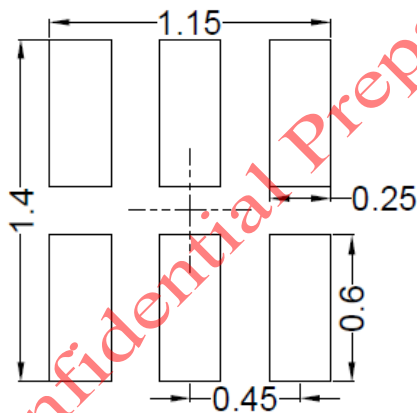

**Recommended PCB layout
(Reference only)**

**Notes: 1, All dimension in millimeter and exclude mold flash & metal burr
2, center line refers chip body center**

单击下面可查看定价，库存，交付和生命周期等信息

[>>SILERGY\(矽力杰\)](#)