



30V Single N-Channel Enhancement-Mode MOSFET

General Description

- Low gate charge.
- Use as a load switch.
- Use in PWM applications

Product Summary

- BV_{DSS} 30V
- $R_{DS(on)}$ @VGS = 10V < 14.0mΩ
- $R_{DS(on)}$ @VGS = 4.5V < 18mΩ

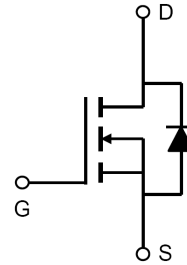
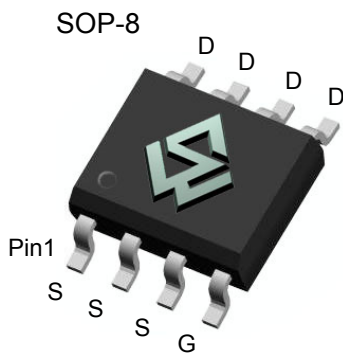

Absolute Maximum Ratings ($T_A = 25^\circ\text{C}$ unless otherwise noted)

Parameter	Symbol	Maximum	Units
Drain-Source Voltage	V_{DS}	30	V
Gate-Source Voltage	V_{GS}	± 20	V
Drain Current ($T_A=25^\circ\text{C}$)	I_D	14	A
Drain Current ($T_A=75^\circ\text{C}$)		8	A
Pulsed Drain Current ^a	I_{DM}	50	A
Avalanche Energy (L= 0.1 mH)	E_{AS}	50	mJ
Power Dissipation ^b ($T_A=25^\circ\text{C}$)	P_D	2.5	W
Power Dissipation ^b ($T_A=75^\circ\text{C}$)		1.8	W
Junction and Storage Temperature Range	T_J, T_{STG}	-55 ~ +150	$^\circ\text{C}$

Thermal Characteristics

Parameter	Symbol	Maximum	Units
Junction-to-Ambient ^a ($t \leq 10\text{s}$)	$R_{\theta JA}$	50	$^\circ\text{C/W}$
Junction-to-Ambient ^{a,d} (Steady-State)		90	$^\circ\text{C/W}$
Junction-to-Lead (Steady-State)	$R_{\theta JL}$	25	$^\circ\text{C/W}$



Electrical Characteristics (T _A = 25°C unless otherwise noted)						
Symbol	Parameter	Conditions	Min	Typ	Max	Units
Off Characteristics						
BV _{DSS}	Drain-Source Breakdown Voltage	V _{GS} = 0V , I _D = 250uA	30			V
I _{DSS}	Zero Gate Voltage Drain Current	V _{DS} = 30V , V _{GS} = 0V			1	uA
I _{GSS}	Gate-Body Leakage Current	V _{GS} = ±20V , V _{DS} = 0V			±100	nA
On Characteristics						
V _{GS(th)}	Gate Threshold Voltage	V _{DS} = V _{GS} , I _D = 250uA	1		3	V
R _{DS(ON)}	Drain-Source On-State Resistance	V _{GS} = 10V , I _D = 14A		10	14	mΩ
		V _{GS} = 4.5V , I _D = 11A		14	18	mΩ
g _{FS}	Forward Transconductance	V _{DS} = 5.0V , I _D = 14A		40		S
Drain-Source Diode Characteristics						
V _{SD}	Diode Forward Voltage	V _{GS} = 0V , I _S = 1.0A			1.1	V
I _S	Maximum Body-Diode Continuous Current				2.5	A
Dynamic Characteristics						
C _{iss}	Input Capacitance	V _{DS} = 15V , V _{GS} = 0V f = 1.0MHz		1190		pF
C _{oss}	Output Capacitance			285		pF
C _{rss}	Reverse Transfer Capacitance			170		pF
Switching Characteristics						
Q _g	Total Gate Charge	V _{DS} = 15V , I _D = 15A V _{GS} = 10V		23		nC
Q _{gs}	Gate-Source Charge			5.2		nC
Q _{gd}	Gate-Drain Charge			5.6		nC
t _{D(ON)}	Turn-On Delay Time	V _{DD} = 15V , I _D = 1A V _{GS} = 10 V R _{GEN} = 6 ohm		10		ns
t _r	Turn-On Rise Time			6		ns
t _{D(OFF)}	Turn-Off Delay Time			32		ns
t _f	Turn-Off Fall Time			7		ns

- a. Repetitive rating, Pulse width limited by junction temperature T_{J(MAX)}=150 °C. Ratings are based on low frequency and duty cycles to keep initial T_J=25 °C
- b. The power dissipation P_D is based on T_{J(MAX)}=150 °C , using ≤10s junction-to-ambient thermal resistance.
- c. The value of R_{θJA} is measured with the device mounted on 1in² FR-4 board with 2oz. Copper, in a still air environment with T_A = 25°C. The value in any given application depends on the user's specific board design.
- d. The R_{θJA} is the sum of the thermal impedance from junction to lead R_{θJL} and lead to ambient.



SOP-8 Package Outline

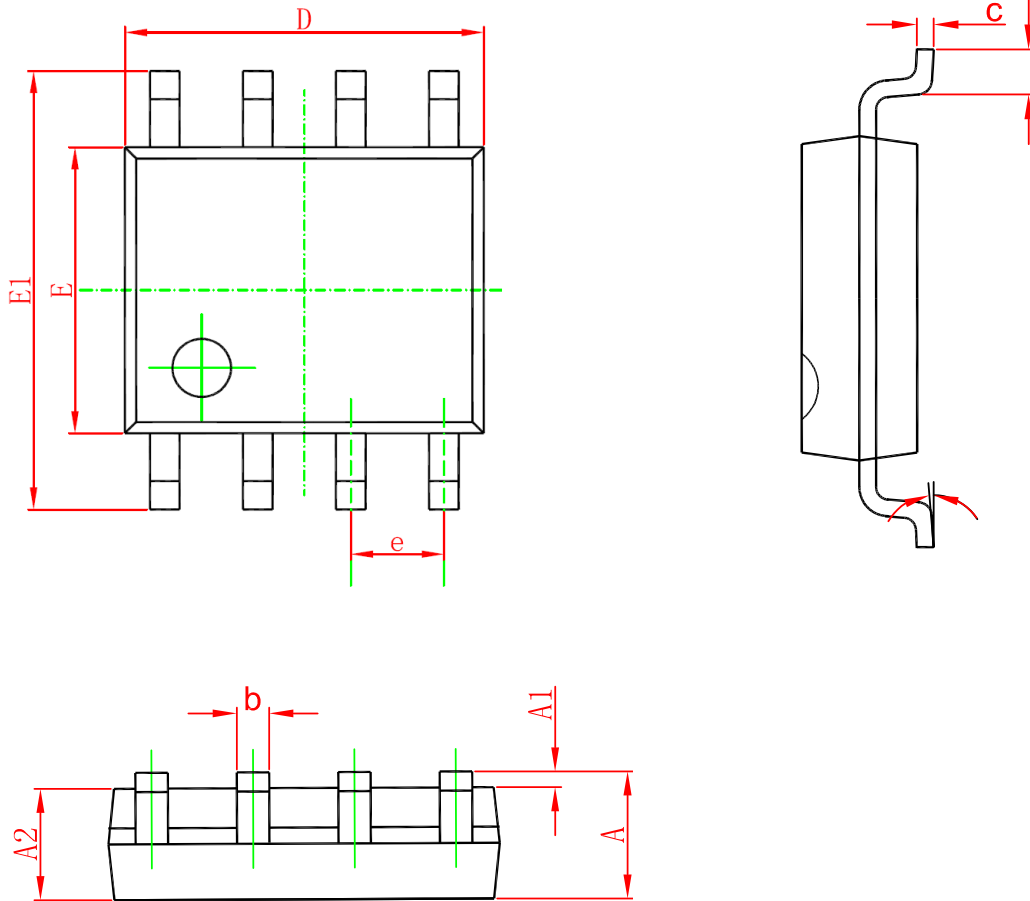

Symbol	Dimensions In Millimeters		Dimensions In Inches	
	Min.	Max.	Min.	Max.
A	1.350	1.750	0.053	0.069
A1	0.100	0.250	0.004	0.010
A2	1.350	1.550	0.053	0.061
b	0.330	0.510	0.013	0.020
c	0.170	0.250	0.006	0.010
D	4.700	5.100	0.185	0.200
E	3.800	4.000	0.150	0.157
E1	5.800	6.200	0.228	0.244
e	1.270(BSC)		0.050(BSC)	
L	0.400	1.270	0.016	0.050
θ	0°	8°	0°	8°

单击下面可查看定价，库存，交付和生命周期等信息

[>>SiliconWisdom\(矽睿半导体\)](#)