



30V Single P-Channel Enhancement-Mode MOSFET

General Description

- Low gate charge.
- Use as a load switch.
- Use in PWM applications

Product Summary

- BV_{DSS} -30V
- $R_{DS(on)}$ @VGS = -10V < 11mΩ
- $R_{DS(on)}$ @VGS = -4.5V < 18mΩ

PDFN3X3-8L

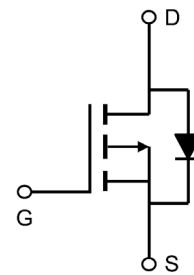
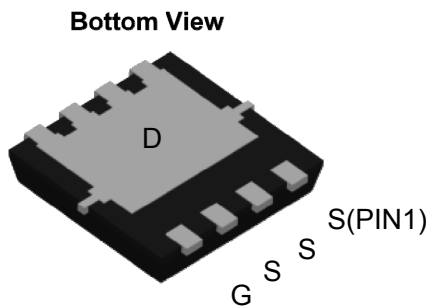
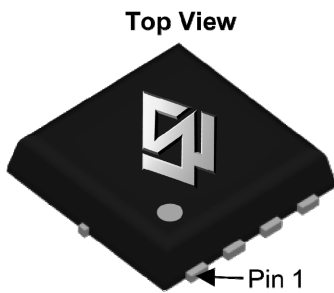

Absolute Maximum Ratings ($T_A = 25^\circ\text{C}$ unless otherwise noted)

Parameter	Symbol	Maximum	Units
Drain-Source Voltage	V_{DS}	-30	V
Gate-Source Voltage	V_{GS}	± 20	V
Drain Current ($T_A=25^\circ\text{C}$)	I_D	-50	A
Drain Current ($T_A=75^\circ\text{C}$)		-21	A
Pulsed Drain Current ^a	I_{DM}	-120	A
Avalanche Energy (L= 0.5 mH, -17A)	E_{AS}	78	mJ
Power Dissipation ^b ($T_C=25^\circ\text{C}$)	P_D	21	W
Power Dissipation ^b ($T_A=25^\circ\text{C}$)		5.5	W
Junction and Storage Temperature Range	T_J, T_{STG}	-55 ~ +150	$^\circ\text{C}$

Thermal Characteristics

Parameter	Symbol	Maximum	Units
Junction-to-Ambient ^a ($t \leq 10\text{s}$)	$R_{\theta JA}$	75	$^\circ\text{C/W}$
Junction-to-Ambient ^{a,d} (Steady-State)		30	$^\circ\text{C/W}$
Junction-to-Lead (Steady-State)	$R_{\theta JL}$	3.36	$^\circ\text{C/W}$



Electrical Characteristics (T _A = 25°C unless otherwise noted)						
Symbol	Parameter	Conditions	Min	Typ	Max	Units
Off Characteristics						
B _V DSS	Drain-Source Breakdown Voltage	V _{GS} = 0V , I _D = -250uA	-30			V
I _{DSS}	Zero Gate Voltage Drain Current	V _{DS} = -30V , V _{GS} = 0V			-1	uA
I _{GSS}	Gate-Body Leakage Current	V _{GS} = ±20V, V _{DS} = 0V			±100	nA
On Characteristics						
V _{GS(th)}	Gate Threshold Voltage	V _{DS} = V _{GS} , I _D = -250uA	-1.0	-1.8	-2.5	V
R _{DS(ON)}	Drain-Source On-State Resistance	V _{GS} = -10V , I _D = -20A		8.4	11	mΩ
		V _{GS} = -4.5V , I _D = -10A		13	18	mΩ
g _{FS}	Forward Transconductance	V _{DS} = -10V , I _D = -15A		30		S
Drain-Source Diode Characteristics						
V _{SD}	Diode Forward Voltage	V _{GS} = 0V , I _S = -1.0A			-1.0	V
I _S	Maximum Body-Diode Continuous Current				-55	A
Dynamic Characteristics						
C _{iss}	Input Capacitance	V _{DS} = -15V , V _{GS} = 0V f = 1.0MHz		2820		pF
C _{oss}	Output Capacitance			335		pF
C _{rss}	Reverse Transfer Capacitance			322		pF
Switching Characteristics						
Q _g	Total Gate Charge	V _{DS} = -15V , I _D = -20A V _{GS} = -4.5V		33		nC
Q _{gs}	Gate-Source Charge			5.9		nC
Q _{gd}	Gate-Drain Charge			7.4		nC
t _{D(ON)}	Turn-On Delay Time	V _{DD} = -15V , I _D = -20A V _{GS} = -10 V R _{GEN} = -3.3 ohm		13.5		ns
t _r	Turn-On Rise Time			22		ns
t _{D(OFF)}	Turn-Off Delay Time			92.3		ns
t _f	Turn-Off Fall Time			65		ns

- Repetitive rating, Pulse width limited by junction temperature T_{J(MAX)}=150 °C. Ratings are based on low frequency and duty cycles to keep initial T_J=25 °C
- The power dissipation P_D is based on T_{J(MAX)}=150 °C , using ≤10s junction-to-ambient thermal resistance.
- The value of R_{θJA} is measured with the device mounted on 1in² FR-4 board with 2oz. Copper, in a still air environment with T_A = 25°C. The value in any given application depends on the user's specific board design.
- The R_{θJA} is the sum of the thermal impedance from junction to lead R_{θJL} and lead to ambient.



PDFN3x3-8L Package

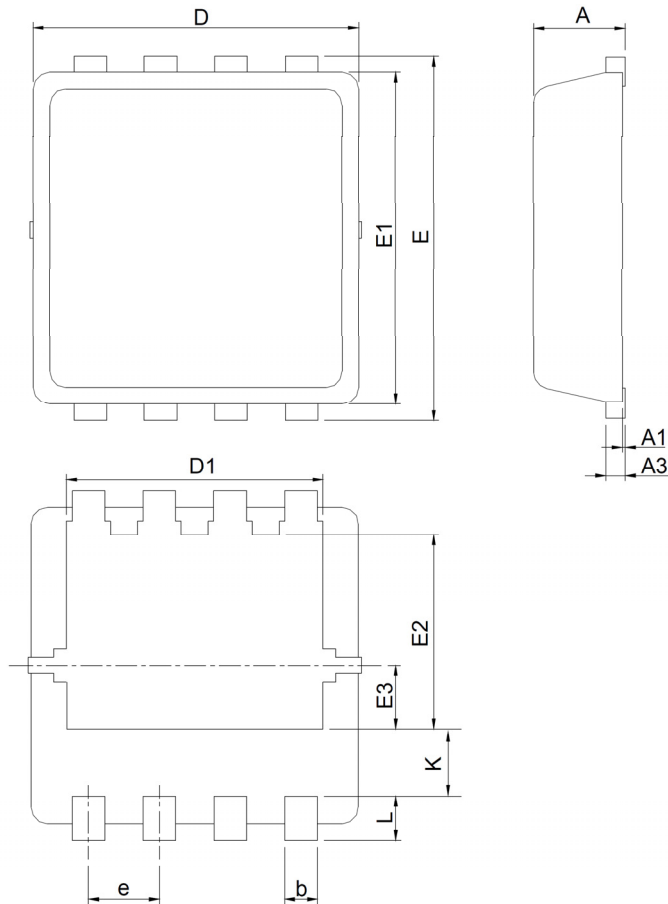

SYMBOL	DFN3x3-8			
	MILLIMETERS		INCHES	
	MIN.	MAX.	MIN.	MAX.
A	0.80	1.00	0.031	0.039
A1	0.00	0.05	0.000	0.002
A3	0.10	0.25	0.004	0.010
b	0.24	0.35	0.009	0.014
D	2.90	3.10	0.114	0.122
D1	2.25	2.45	0.089	0.096
E	3.10	3.30	0.122	0.130
E1	2.90	3.10	0.114	0.122
E2	1.65	1.85	0.065	0.073
E3	0.56	0.58	0.022	0.023
e	0.65 BSC		0.026 BSC	
K	0.475	0.775	0.019	0.031
L	0.30	0.50	0.012	0.020

RECOMMENDED LAND PATTERN

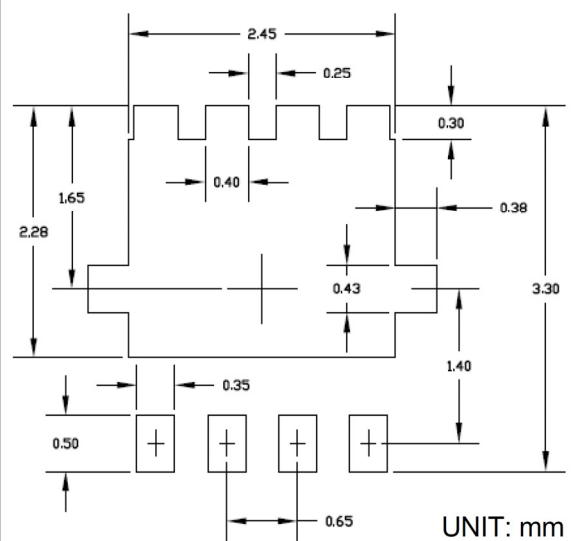

单击下面可查看定价，库存，交付和生命周期等信息

[>>SiliconWisdom\(矽睿半导体\)](#)