

1. General Description

SWF1828A is single-cell lithium-ion/lithium polymer rechargeable battery protection IC. Integrated low R_{dson} power MOSFET and only two external components make the protection board highly compact. SWF1828A has full protection including over charging voltage protection, over discharging voltage protection, over current protection, short protection and over temperature protection. SWF1828A is available in SOT-23 package

2. Features

1. Integrate 50 mΩ R_{dson} Power MOSFET
2. Ultra-small SOT-23 Package
3. Over-temperature Protection
4. Three steps Over current protection
5. Low Current Consumption
 - Operation Mode: 1.5 μA .
 - Power-down Mode: 0.5 μA .
6. RoHS Compliant and Lead (Pb) Free

3. Applications

- 1-cell lithium-ion rechargeable battery packs
- 1-cell lithium polymer rechargeable battery packs

4. Package and Pin Description

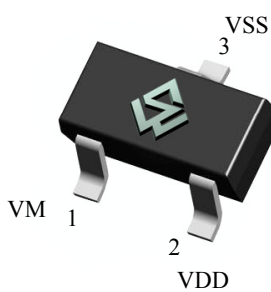
Pin	Symbol	Description	SOT-23
1	VM	Connect to Output Ground	
2	VDD	Power Supply	
3	VSS	Battery Ground	
-	-	-	
-	-	-	

5. Absolute Maximum Ratings

(Note: Do not exceed these limits to prevent damage to the device. Exposure to absolute maximum rating conditions for long periods may affect device reliability.)

Parameter	Symbol	Value	Unit
VDD input pin voltage	V_{DD}	$V_{SS}-0.3 \sim V_{SS}+6$	V
VDD input pin voltage	V_{VM}	-8~ +10	V
Operating Ambient Temperature	T_{OP}	-40~+85	°C
Maximum Junction Temperature	T_{ST}	-40~+125	°C
Power Dissipation at T=25°C	P_D	200	mW
ESD (HBM)	ESD	4000	V



6. Electrical Characteristics

(VSS=0V, Ta=25°C, unless otherwise specified)

Parameter	Symbol	Condition	Min	Typ.	Max	Unit
Input Voltage						
VDD input pin voltage	V _{DSOP1}	-	0	-	6.0	V
VM input pin voltage	V _{DSOP2}	-	-6.0	-	6.0	V
Current Consumption						
Operating Current	I _{DD}	VDD=3.9V		1.5	5.0	μA
Power Down Current	I _{PD}	VDD=2.0V		0.5	1.0	μA
Detection Voltage						
Overcharge Protection Voltage	V _{CO}	R1=100Ω	4.250	4.300	4.350	V
Overcharge Protection Release Voltage	V _{CR}	R1=100Ω	4.080	4.150	4.220	V
Overdischarge Protection Voltage	V _{DL}	R1=100Ω	2.700	2.800	2.900	V
Overdischarge Protection Release Voltage	V _{DR}	R1=100Ω	2.900	3.000	3.100	V
Overdischarge Protection Current	I _{IOV}	V _{DD} =3.5V	0.4	0.8	1.3	A
Load Short-Circuiting Detection	I _{Short}	V _{DD} =3.5V	1.0	1.5	2.0	A
Overcharge Protection Current	I _{COV}	V _{DD} =3.5V	0.3	0.8	1.3	A
Detection Delay Time						
Overcharge Voltage Detection Delay Time	T _{OC}	V _{DD} =3.8V → 4.5V		100		ms
Overdischarge Voltage Detection Delay Time	T _{OD}	V _{DD} =3.2V → 2.2V		100		ms
Overdischarge Current Delay Time	T _{DIP}	V _{DD} =3.0V		50		ms
Load Short-Circuiting Detection Delay Time	T _{SIP}	V _{DD} =3.6V		150		μs
FET on Resistance						
Equivalent FET on Resistance	R _{ds(on)}	V _{DD} =3.6V, I _{VM} =1.0A,	45	50	60	mΩ
0V Charging						
0V Charge Voltage	V _{0CH}	Can Be Charged	-	-	-	V

7. Typical Application Circuit

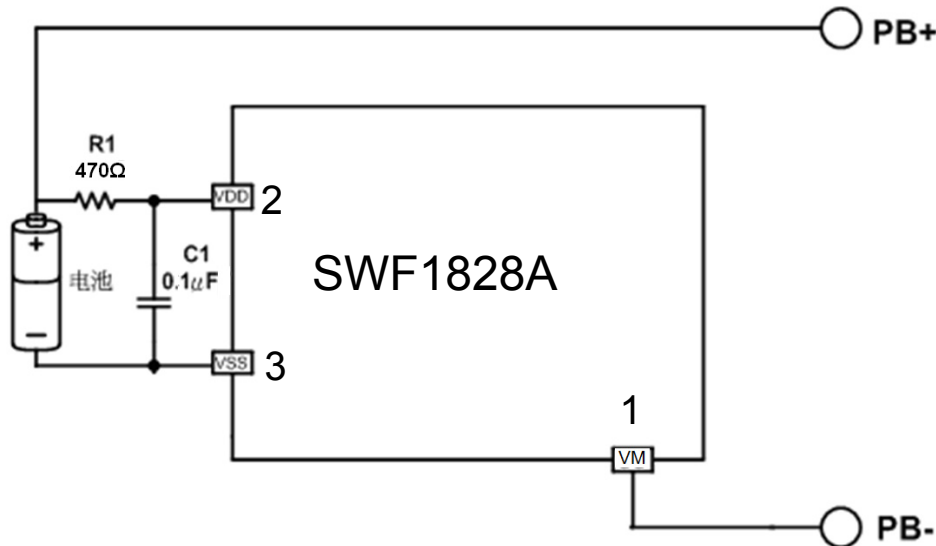

8. Description of Operation

8.1. Normal Status

SWF1828A monitors the battery voltage VDD and VM pin voltage to control charging and discharging. When VDD voltage is between overdischarge detection voltage and overcharge detection voltage, and VM voltage is in the range from the charger detection voltage to discharge overcurrent detection voltage, the IC turns MOSFET on. This condition is called the normal status. Under this condition, charging and discharging can both be carried out freely.

8.2. Overcharge Protection

When the voltage of the battery cell exceeds the overcharge protection voltage (VOCV) beyond the overcharge delay time (TOCV) period, charging is inhibited by turning off power MOSFET. The overcharge condition is released in two cases:

1. The voltage of the battery cell becomes lower than the overcharge release voltage (VOCR) through self-discharge.
2. The voltage of the battery cell falls below the overcharge protection voltage (VOCV) and a load is connected. When the battery voltage is above VOCV, the overcharge condition will not release even a load is connected to the pack.

8.3. Over Charging Current Protection

When the charging current becomes higher than discharge protection Current (ICHA) and beyond over discharge current delay time period, charging is inhibited. Inhibition of charging is immediately released when the charger is removed.

8.4. Overdischarge Protection

When the voltage of the battery cell goes below the overdischarge protection voltage (VODV) beyond the overdischarge delay time (TODV) period, discharging is inhibited. Inhibition of discharging is immediately released when the voltage of the battery cell becomes higher than overdischarge release voltage (VODR).

8.5. Overcurrent Protection

When the discharging current becomes higher than a specified Overdischarge Current and beyond over discharge current delay time period, discharging is inhibited. Inhibition of discharging is immediately released when the load is released or the impedance between EB+ and EB- is larger than 500kΩ. The SWF1828A provides three over current detection levels with three over current delay time corresponding to each over current detection level.

8.6. Over Temperature Protection

When IC temperature becomes higher than a specified value, SWF1828A will turn off Power MOSFET whatever in discharging or charging condition. In discharging condition, Inhibition of discharging is released when temperature lower than Over Temperature Recovery Degree and load also released. In charging condition, Inhibition of charging is released when temperature lower than over temperature recovery degree and charger also removed.

8.7. Charger detection

When over discharge occurs, discharging is inhibited. However, charging is still permitted through the parasitic diode of MOSFET. Once the charger is connected to the battery pack, SWF1828A detects the voltage between VM and GND is below charge detection threshold voltage (VCHA), Power MOSFET will turn on when Battery cell voltage is higher than Overdischarge Protection Voltage.

8.8. Power Saving after Overdischarge

When overdischarge occurs, the SWF1828A will enter into power-down mode.



SiliconWisdom

Lithium-ion/Polymer Battery Protection IC SWF1828A

9. SOT-23 Package Outline Dimensions

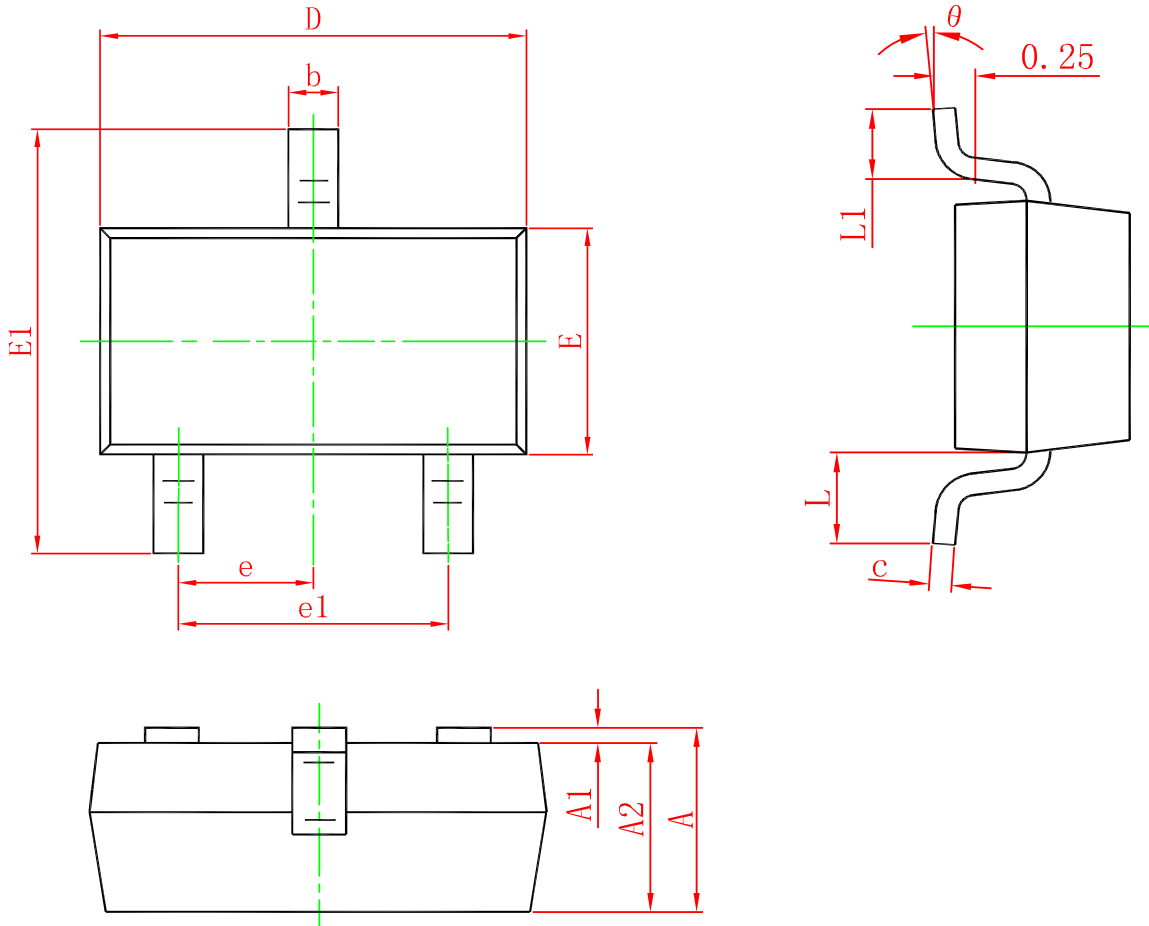

Symbol	Dimensions In Millimeters		Dimensions In Inches	
	Min.	Max	Min.	Max.
A	0.900	1.150	0.035	0.045
A1	0.000	0.100	0.000	0.004
A2	0.900	1.050	0.035	0.041
b	0.300	0.500	0.012	0.020
c	0.080	0.150	0.003	0.006
D	2.800	3.000	0.110	0.118
E	1.200	1.400	0.047	0.055
E1	2.250	2.550	0.089	0.100
e	0.950 TYP.		0.037 TYP.	
e1	1.800	2.000	0.071	0.079
L	0.550 REF.	0.022 REF.		
theta	0.300	0.500	0.012	0.020

单击下面可查看定价，库存，交付和生命周期等信息

[>>SiliconWisdom\(矽睿半导体\)](#)