

# Surface Mount Auto Surge Suppressor

## Working Peak Reverse Voltage - 22 to 42 Volts

## 10000 Watt Peak Pulse Power

### Features

- Glass passivated chip
- 10000 W peak pulse power capability with a 10/1000 $\mu$ s waveform, repetitive rate (duty cycle): 0.01 %
- Meet AEC-Q101 requirement
- Low leakage
- Uni-directional polarity
- Excellent clamping capability
- Very fast response time
- RoHS compliant



### Mechanical Data

- Plastic package DO-218AB/SOD-BLOCK
- Epoxy: UL 94V-0 rate flame retardant
- Polarity: Heatsink is anode

### Maximum Ratings ( $T_A=25^{\circ}\text{C}$ unless otherwise noted )

RATING	SYMBOL	VALUE	UNITS
Peak power dissipation with a 10/1000 $\mu$ s waveform (Note 1)	$P_{PP}$	10000	Watts
Peak pulse current with a 10/1000 $\mu$ s waveform (Note 1)	$I_{PP}$	SEE TABLE 1	Amps
Power dissipation on infinite heatsink at $T_L = 25^{\circ}\text{C}$	$P_D$	8.0	Watts
Peak Forward Surge Current, 8.3ms Single Half Sine-Wave	$I_{FSM}$	700	Amps
Operating junction and storage temperature range	$T_J, T_{STG}$	-55 to +175	$^{\circ}\text{C}$

#### Notes :

1. Non-repetitive current pulse, per Fig. 2 and derated above  $T_A = 25^{\circ}\text{C}$  per Fig. 1.

Dimensions (DO-218AB)

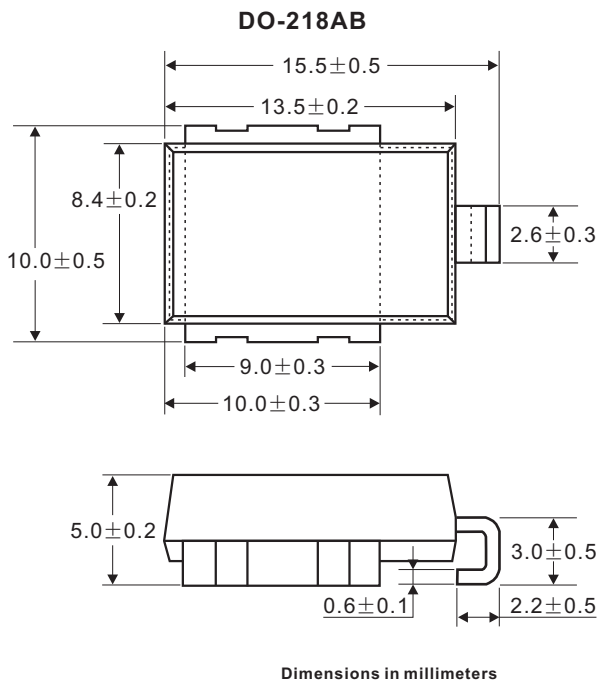

Recommended Mounting Pad Layout

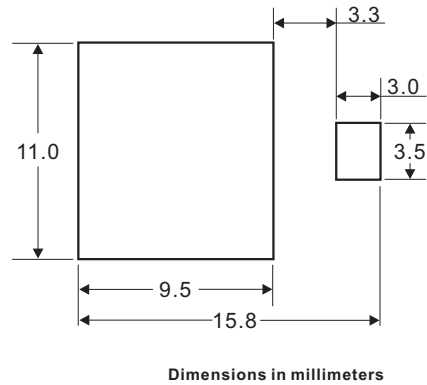

Electrical Characteristics

TABLE 1

\*\*\*Stand for commonly used models

ASC Part Number	Working Peak Reverse Voltage	Breakdown Voltage $V_{BR}@I_T$			Max. Reverse Leakage $I_R$ @ $V_{RWM}$	Max. $I_R$ @ $V_{RWM}$ $T_J=175^\circ C$	Max. Clamping Voltage $V_c$ @ $I_{pp} 10/1000\mu s$	
	$V_{RWM}(V)$	$V_{BR}(V)Min.$	$V_{BR}(V)Max.$	$I_T(mA)$	$I_R(\mu A)$	$I_R(\mu A)$	$V_c(V)$	$I_{pp}(A)$
ASC22A	22	24.4	26.9	5	10	150	35.5	281.6
ASC33A	33	36.7	40.6	5	10	150	53.3	187.6
* ASC36A	36	40.0	44.2	5	10	150	58.1	172.1

IEC Compatibility

ISO16750-2 Test A Test Waveform

ASC Part Number	12V system	24V system	Resistance				
	100V@400ms	202V@350ms	0.5Ω	1Ω	2Ω	4Ω	8Ω
ASC22A	√	-	?	√	√	√	√
ASC33A	-	√	-	×	?	√	√
ASC36A	-	√	-	×	?	√	√

Notes :

- ? :The test results would be different depending on the specific circuit parameters or test environment
- x :Failed

Ratings and Characteristic Curves (TA=25 °C unless otherwise noted)

Fig.1 Power Derating Curve

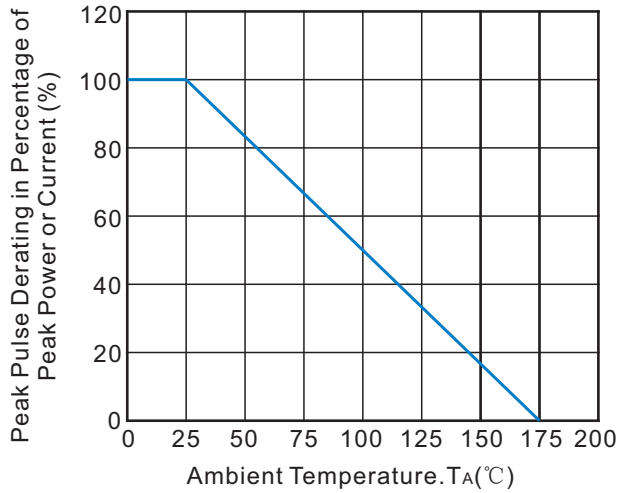

Fig.2 Pulse Waveform

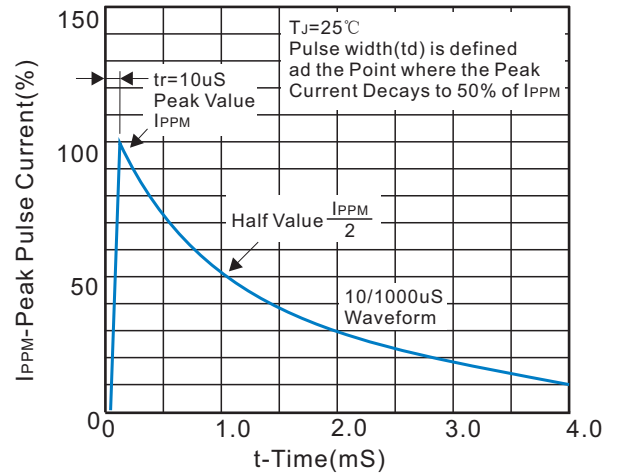

Fig.3 Steady State Power Derating Curve

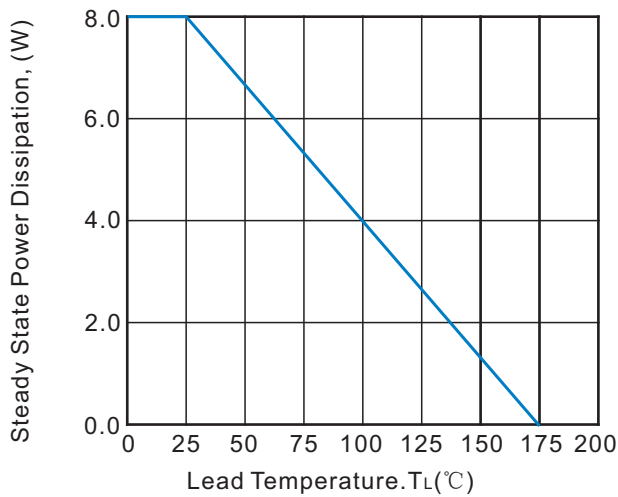

Fig.4 Peak Pulse Power Rating Cure

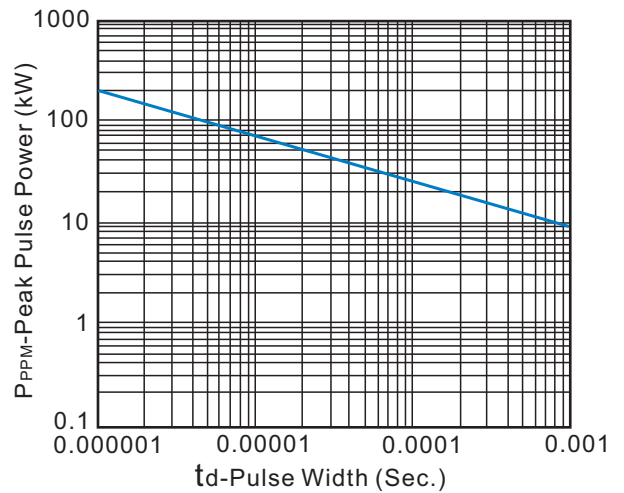
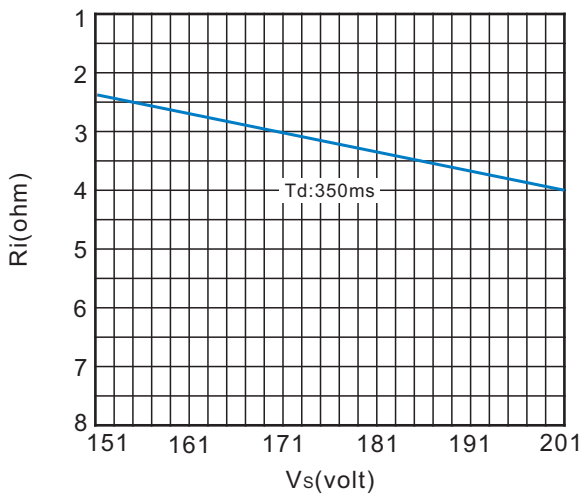

Fig.5 Ri-Vs chart for ISO-16750-2 Test A : 24V System



## Recommended Soldering Conditions

### Recommended Conditions

IR Reflow Condition		
Pre Heat	Temperature Min( $T_{s(min)}$ )	150°C
	Temperature Max( $T_{s(max)}$ )	200°C
	Time(Min to Max)( $t_s$ )	60-180secs
Ramp up rate(150-200°C)		3°C/sec.Max.
Reflow	Temperature( $T_L$ )(Liquidus)	220°C. Min.
	Temperature( $t_L$ )	60-150secs
	Peak Temp( $T_P$ )	245°C
Ramp up rate(220-200°C)		3°C/sec.Max.
Time within actual Peak Temp( $t_P$ )		10-30 secs
Ramp-down Rate		3°C/sec.Max.
Time 25°C to Peak Temp( $T_P$ )		6 min.Max.
Do not exceed		245°C

### Reflow Soldering

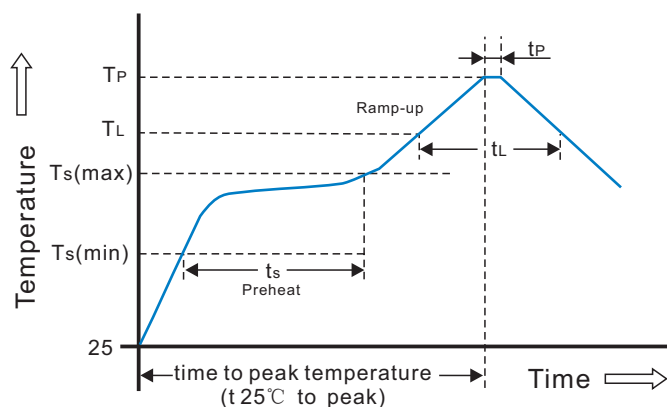

## Marking Code

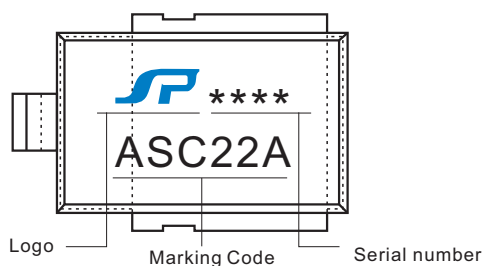

## Tape And Reel Specification

Symbol	Ea Per Reel	REEL DIA (mm)	Industry Standard
ASC***	750	330	EIA RS-481

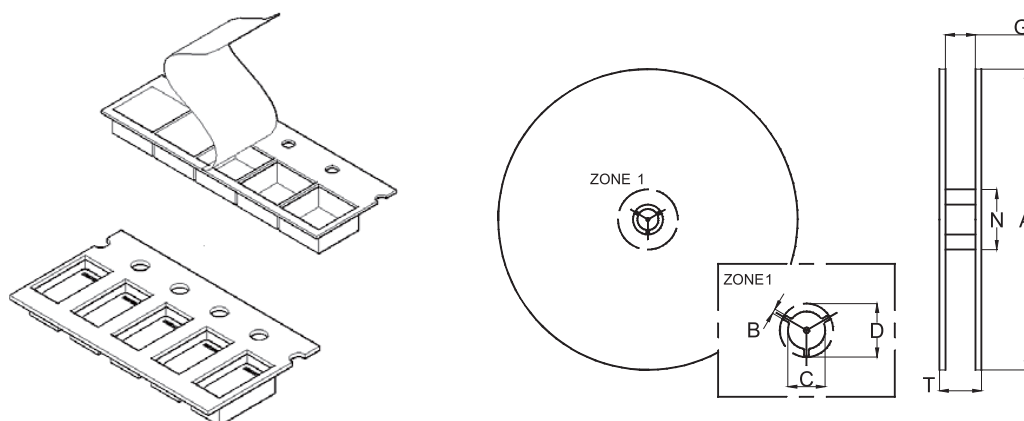

Tape Size	A Max.	B Min.	C	D Min.	N Min.	G Max.	T Max.
24(0.945)	330±2.0 (13.0±0.079)	1.5(0.059)	13.0±0.50 (0.51±0.002)	20.2(0.795)	50(1.97)	26.4(1.039)	30.4(1.197)

单击下面可查看定价，库存，交付和生命周期等信息

[>>SPSEMI](#)