

Electro-Static Discharge TUSD03CBV Bidirectional TVS Diode/Low Clamping Voltage

DFN1006

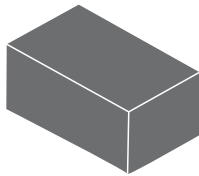

Pin Configuration

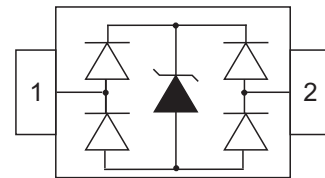

Features

- 34Watts Peak Pulse Power per Line (tp=8/20μs)
- Protects one birectional I/O line
- Low clamping voltage
- Working voltages : 3.3V
- Low leakage current

IEC Compatibility

- IEC61000-4-2 (ESD) ±25kV (air), ±20kV (contact)
- IEC61000-4-4 (EFT) 40A (5/50ns)

Applications

- USB 2.0 and USB 3.0
- HDMI 1.3, HDMI 1.4 and HDMI 2.0
- Personal Digital Assistants (PDA's)
- Notebooks, Desktops, and Servers
- SATA and eSATA interface
- IEEE 1394
- DVI

Mechanical Characteristics

- JEDEC DFN1006 Package
- Molding Compound Flammability Rating : UL 94V-O
- Quantity Per Reel : 10,000pcs
- Reel Size : 7 inch
- Lead Finish : Lead Free

Maximum Ratings($T_A=25^{\circ}\text{C}$ unless otherwise specified)

Parameter	Symbol	Value	Units
Peak Pulse Power($t_p=8/20\mu\text{s}$)	P_{PP}	34	Watts
Lead Soldering Temperature	T_L	260(10 sec.)	$^{\circ}\text{C}$
Operating Temperature Range	T_J	-40~85	$^{\circ}\text{C}$
Storage Temperature Range	T_{STG}	-55~150	$^{\circ}\text{C}$

Electrical Characteristics($T_A=25^{\circ}\text{C}$ unless otherwise specified)
TUSD03CBV(Marking:3U or S1)

Parameter	Symbol	Conditions	Min.	Typ.	Max.	Units
Reverse Stand-off Voltage	V_{RWM}				3.3	V
Breakdown Voltage	V_{BR}	$I_T=1\text{mA}$	7.0			V
Clamping Voltage ¹⁾	V_C	$I_{PP}=1\text{A}, t_p=8/20\mu\text{s}$		4.5	5.5	V
		$I_{PP}=4\text{A}, t_p=8/20\mu\text{s}$		7.0	8.5	V
Clamping Voltage ²⁾	V_C	$V_{ESD}=8\text{kv}$		9		
Reverse Leakage Current	I_R	@ V_{RWM}			1	μA
Junction Capacitance	$C_{I/O}$	0Vdc, f=1MHz Between I/O Pins and GND		0.35	0.5	pF

Notes:

- 1) Non-repetitive current pulse ,accodin to IEC61000-4-5
- 2) Contact discharge mode ,accodin to IEC61000-4-2

Electrical Characteristics ($T_A=25^\circ\text{C}$ unless otherwise specified)

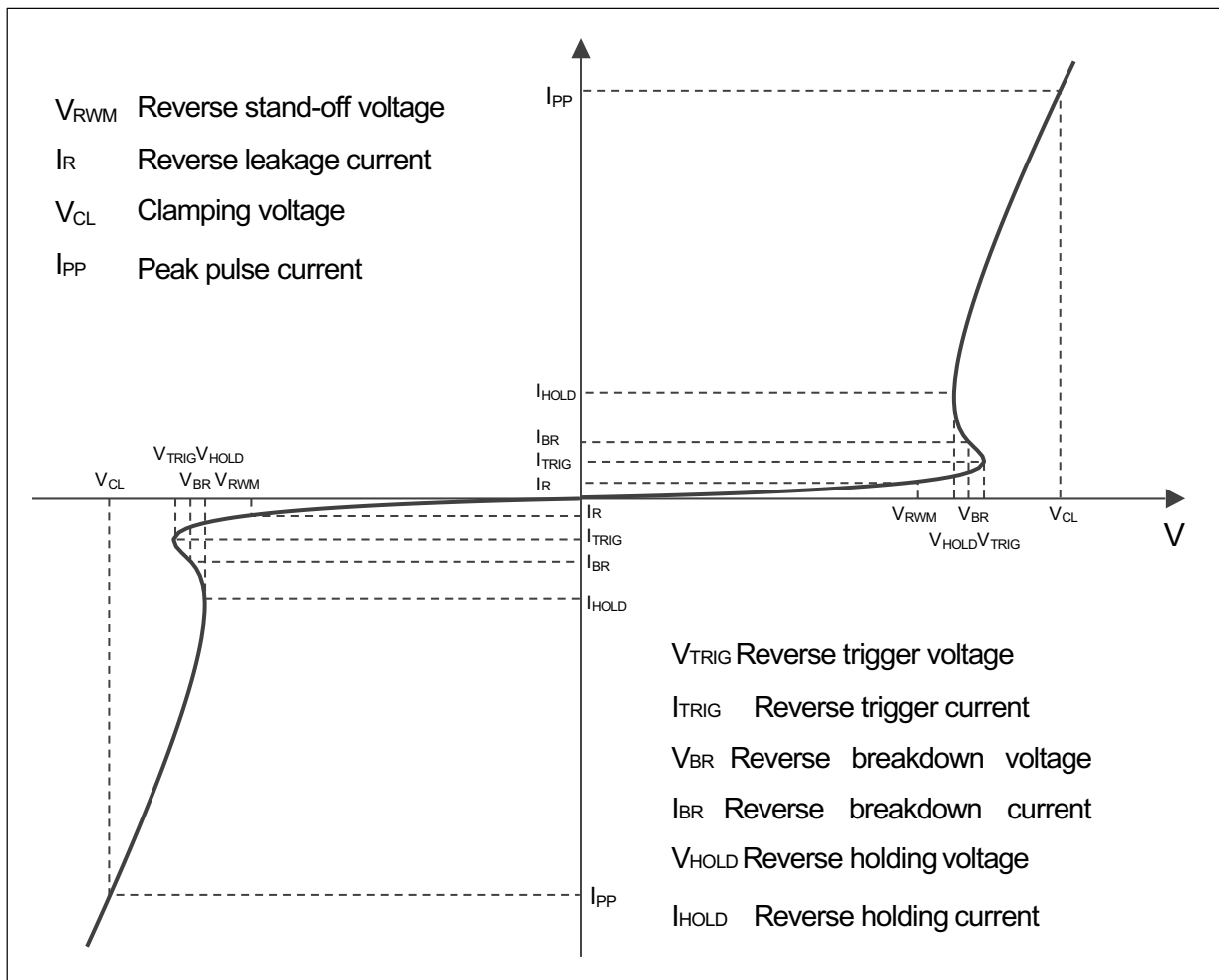

Ratings and Characteristic Curves

Fig.1 Non-Repetitive Pulse Power vs. Pulse Time

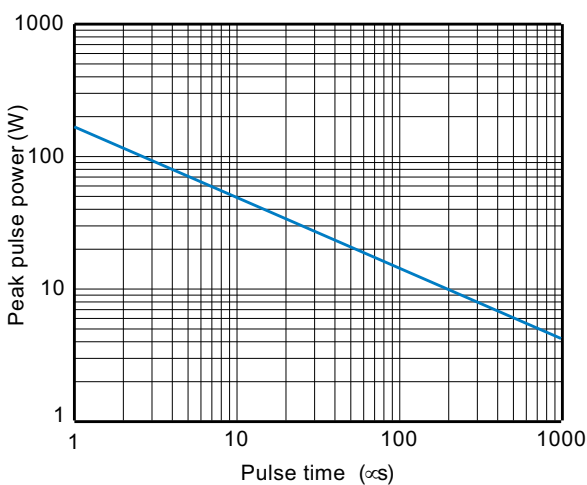

Fig.2 Pulse Waveform

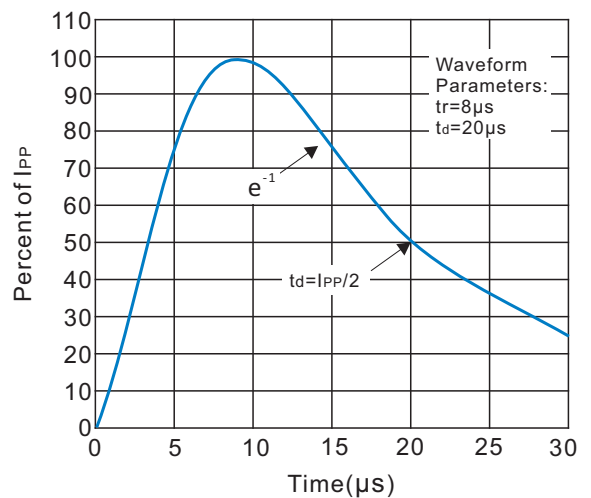

Fig.3 Power Derating Curve

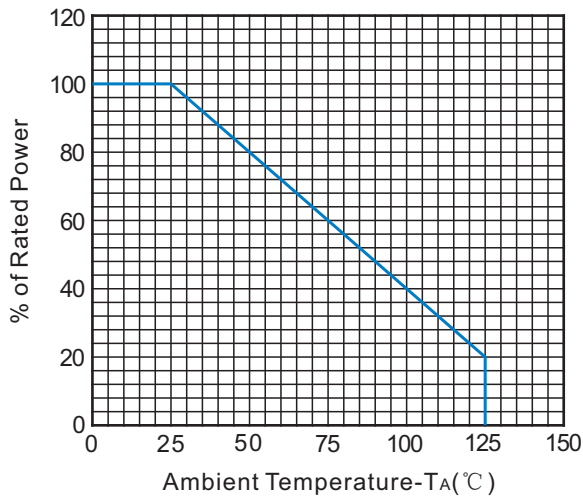
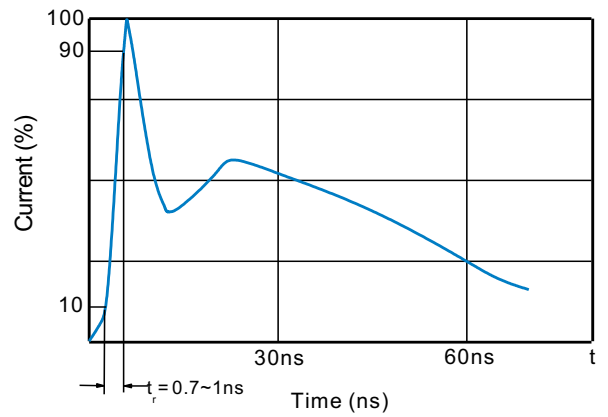
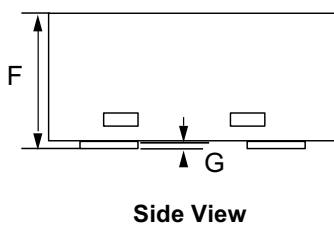
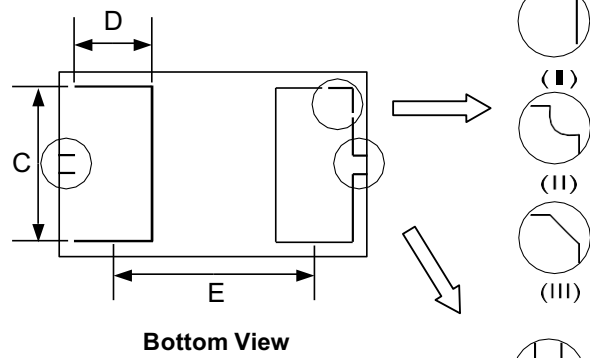
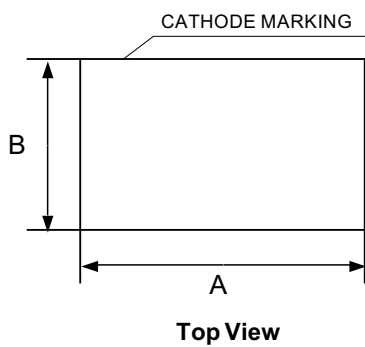

Fig.4 Contact discharge current waveform per IEC61000-4-2



Dimensions(DFN1006)



DIM	Millimeters		Inches	
	Min	Max	Min	Max
A	0.95	1.08	0.037	0.043
B	0.55	0.68	0.022	0.027
C	0.45	0.55	0.017	0.022
D	0.20	0.40	0.008	0.016
E	0.65BSC		0.026BSC	
F	0.34	0.55	0.013	0.022
G	0.00	0.10	0.000	0.004

单击下面可查看定价，库存，交付和生命周期等信息

[>>SPSEMI](#)