

Features

- Low $R_{DS(on)}$ @ $V_{GS}=-4.5V$
- -3.3V Logic Level Control
- P Channel SOT23 Package
- HMB ESD Protection 2KV
- Pb-Free, RoHS Compliant

$V_{(BR)DSS}$	$R_{DS(ON)}$ Typ	I_D Max
-20V	38mΩ @ -4.5V	-4.8A
	43mΩ @ -3.3V	

Applications

- Load Switch
- Switching circuits
- High-speed line driver
- Power Management Functions

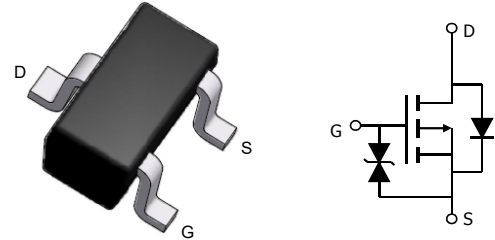

SOT23

Order Information

Product	Package	Marking	Packing
SP4002AES	SOT23	A5E	3000PCS/Reel

Absolute Maximum Ratings

Stresses exceeding Maximum Ratings may damage the device. Maximum Ratings are stress ratings only. Functional operation above the Recommended Operating Conditions is not implied. Extended exposure to stresses above the Recommended Operating Conditions may affect device reliability.

Symbol	Parameter	Rating	Unit
Common Ratings (TA=25°C Unless Otherwise Noted)			
V_{GS}	Gate-Source Voltage	±8	V
$V_{(BR)DSS}$	Drain-Source Breakdown Voltage	-20	V
T_J	Maximum Junction Temperature	150	°C
T_{STG}	Storage Temperature Range	-50 to 150	°C
Mounted on Large Heat Sink			
I_{DM}	Pulse Drain Current Tested①	$T_A=25°C$	-30 A
I_D	Continuous Drain Current	$T_A=25°C$	-4.8 A
		$T_A=70°C$	-3.6 A
P_D	Maximum Power Dissipation	$T_A=25°C$	1.5 W
		$T_A=70°C$	1.0 W
$R_{\theta JA}$	Thermal Resistance Junction-Ambient	80	°C/W

Symbol	Parameter	Condition	Min	Typ	Max	Unit
Static Electrical Characteristics @ T_J = 25°C (unless otherwise stated)						
V _{(BR)DSS}	Drain-Source Breakdown Voltage	V _{GS} =0V I _D =-250μA	-20	--	--	V
I _{DSS}	Zero Gate Voltage Drain Current(T _A =25°C)	V _{DS} =-20V, V _{GS} =0V	--	--	-1	μA
	Zero Gate Voltage Drain Current(T _A =125°C)	V _{DS} =-16V, V _{GS} =0V	--	--	-100	uA
I _{GSS}	Gate-Body Leakage Current	V _{GS} =±8V, V _{DS} =0V	--	--	±10	μA
V _{GS(TH)}	Gate Threshold Voltage	V _{DS} =V _{GS} , I _D =-250μA	-0.4	-0.7	-1.2	V
R _{DS(ON)}	Drain-Source On-State Resistance②	V _{GS} =-4.5V, I _D =-4A	--	38	45	mΩ
R _{DS(ON)}	Drain-Source On-State Resistance②	V _{GS} =-3.3V, I _D =-3A	--	43	55	mΩ
R _{DS(ON)}	Drain-Source On-State Resistance②	V _{GS} =-2.5V, I _D =-2A	--	52	65	mΩ
Dynamic Electrical Characteristics @ T_J = 25°C (unless otherwise stated)						
C _{iss}	Input Capacitance	V _{DS} =-10V, V _{GS} =0V, f=1MHz	--	675	--	pF
C _{oss}	Output Capacitance		--	120	--	pF
C _{rss}	Reverse Transfer Capacitance		--	85	--	pF
Q _g	Total Gate Charge	V _{DS} =-10V I _D =-4A, V _{GS} =-4.5V	--	14.2	--	nC
Q _{gs}	Gate Source Charge		--	3.2	--	nC
Q _{gd}	Gate Drain Charge		--	5.8	--	nC
Switching Characteristics						
t _{d(on)}	Turn on Delay Time	V _{DD} =-10V, I _D =-2A, R _G =3.3Ω, V _{GS} =-4.5V	--	15	--	ns
t _r	Turn on Rise Time		--	11	--	ns
t _{d(off)}	Turn Off Delay Time		-	22	--	ns
t _f	Turn Off Fall Time		--	35	--	ns
Source Drain Diode Characteristics						
I _{SD}	Source drain current(Body Diode)	T _A =25°C	--	--	-2	A
V _{SD}	Forward on voltage②	T _J =25°C, I _{SD} =-2A, V _{GS} =0V	--	-0.83	-1.2	V

Notes:

- ① Pulse width limited by maximum allowable junction temperature
- ② Pulse test ; Pulse width≤300μs, duty cycle≤2%.

Typical Characteristics

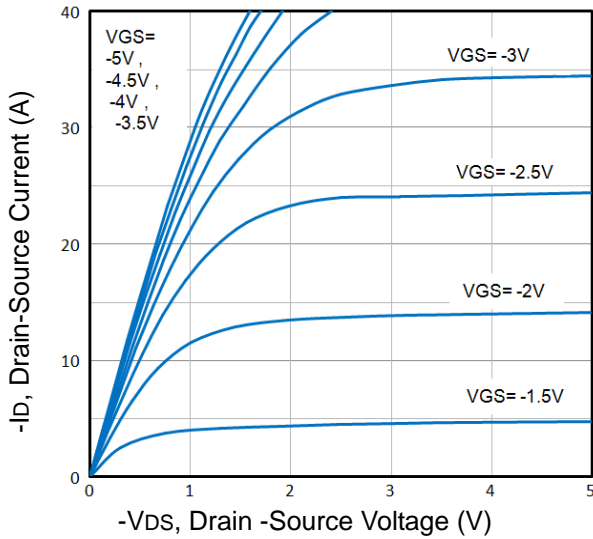

Fig1. Typical Output Characteristics

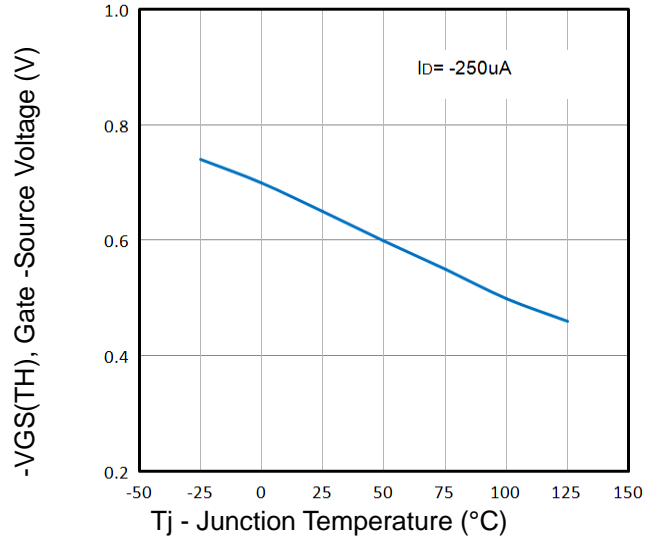

Fig2. Normalized Threshold Voltage Vs. Temperature

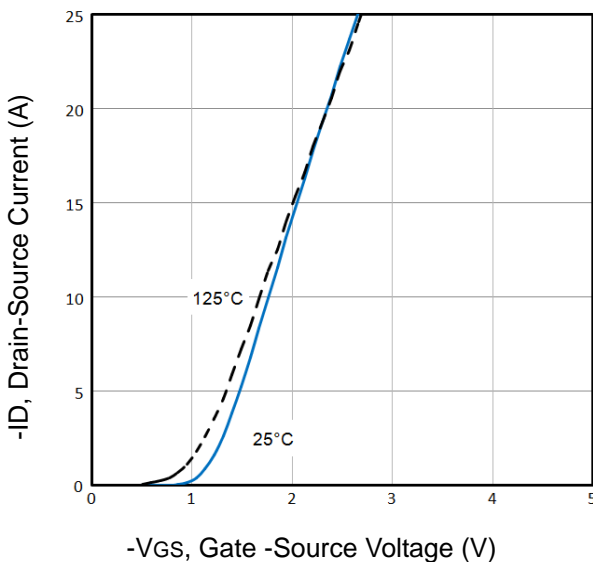

Fig3. Typical Transfer Characteristics

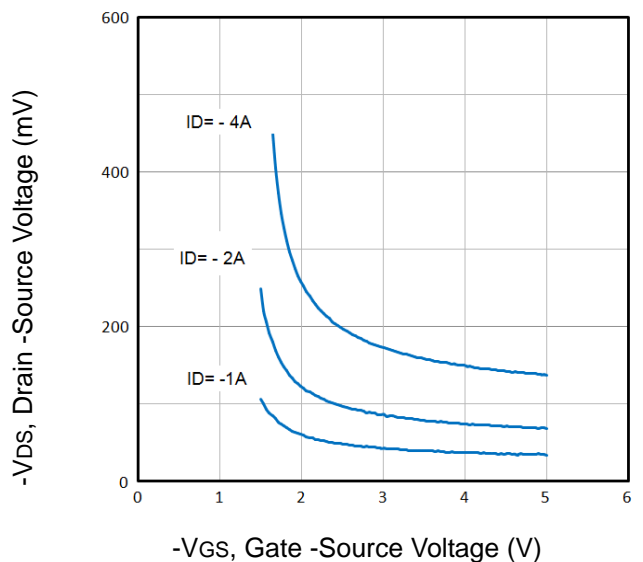

Fig4. Drain-Source Voltage vs Gate-Source Voltage

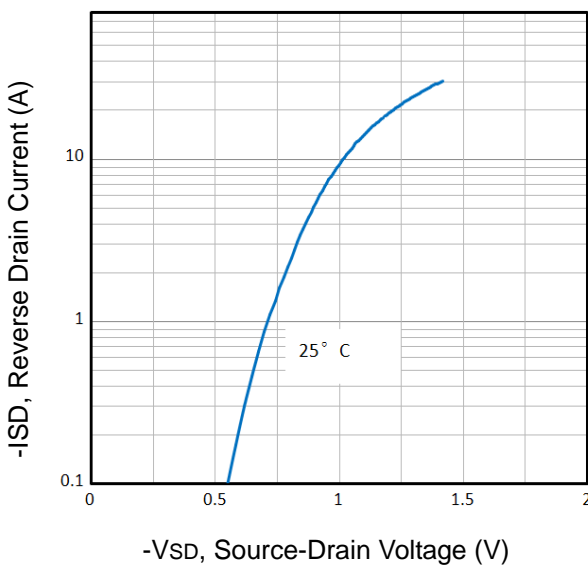

Fig5. Typical Source-Drain Diode Forward Voltage

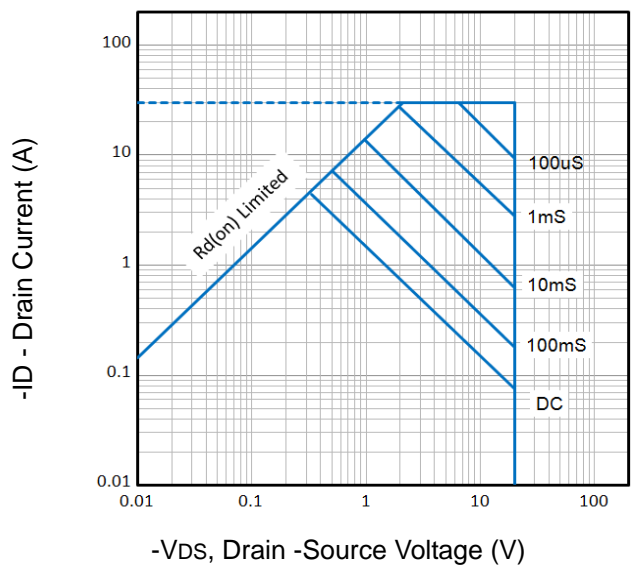

Fig6. Maximum Safe Operating Area

Typical Characteristics

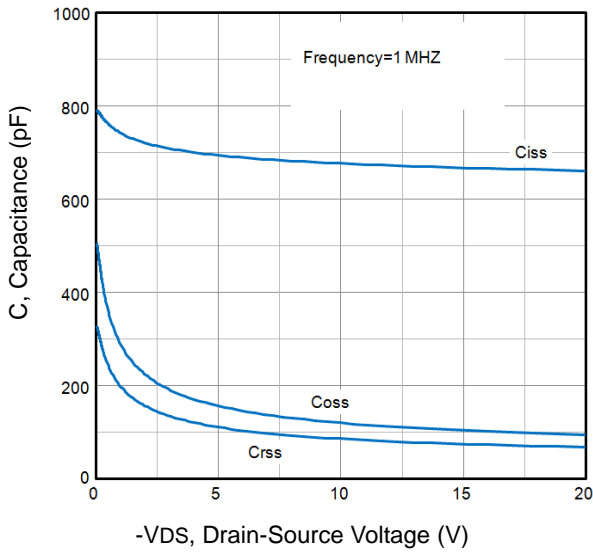

Fig7. Typical Capacitance Vs. Drain-Source Voltage

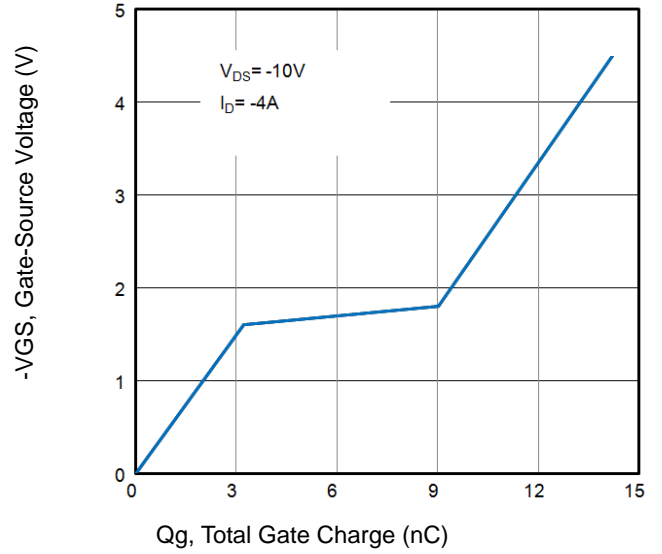

Fig8. Typical Gate Charge Vs. Gate-Source Voltage

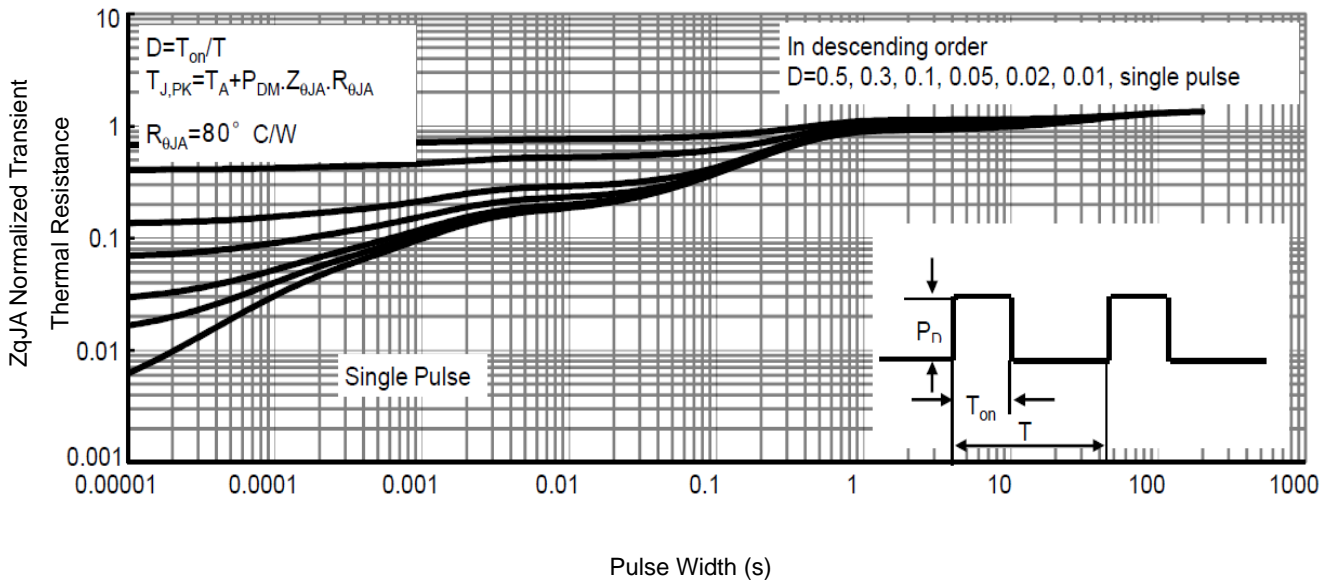

Fig9. Normalized Maximum Transient Thermal Impedance

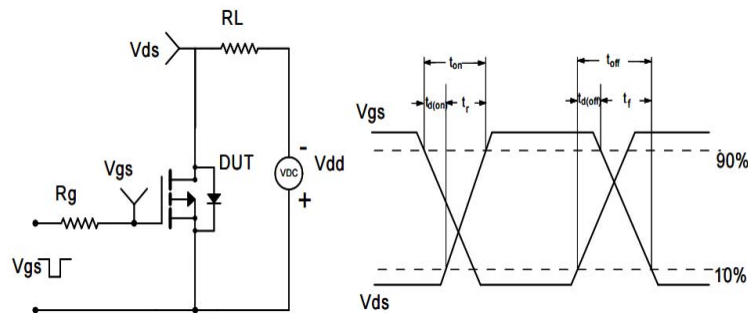
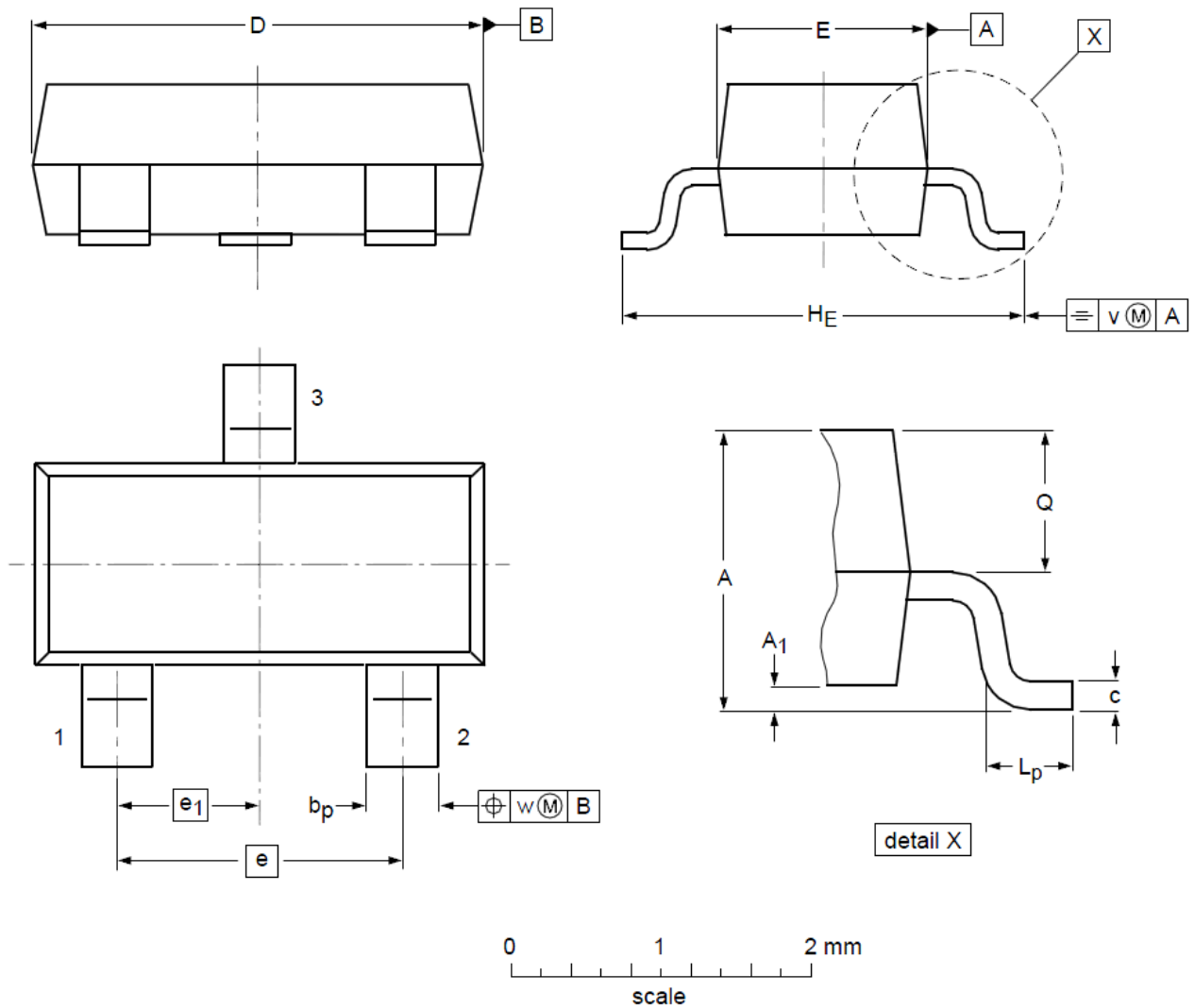

Fig10. Switching Time Test Circuit and waveforms

SOT23 Mechanical Data



DIMENSIONS (unit : mm)

Symbol	Min	Typ	Max	Symbol	Min	Typ	Max
A	0.90	1.01	1.15	A ₁	0.01	0.05	0.10
b _p	0.30	0.42	0.50	c	0.08	0.13	0.15
D	2.80	2.92	3.00	E	1.20	1.33	1.40
e	--	1.90	--	e ₁	--	0.95	--
H _E	2.25	2.40	2.55	L _p	0.30	0.42	0.50
Q	0.45	0.49	0.55	v	--	0.20	--
w	--	0.10	--				

单击下面可查看定价，库存，交付和生命周期等信息

[>>SPSEMI](#)