

STARPOWER

SEMICONDUCTOR

IGBT

GD100PIY120C6SN

Molding Type Module

1200V/100A PIM in one-package

General Description

STARPOWER IGBT Power Module provides ultra low conduction loss as well as short circuit ruggedness. They are designed for the applications such as general inverters and UPS.

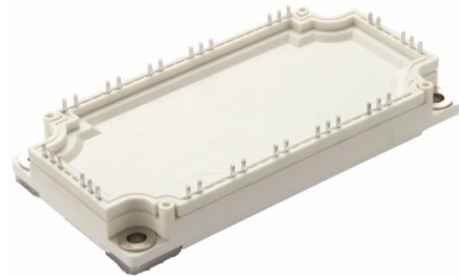

Features

- Low $V_{CE(sat)}$ Trench IGBT technology
- 10 μ s short circuit capability
- $V_{CE(sat)}$ with positive temperature coefficient
- Maximum junction temperature 175 $^{\circ}$ C
- Low inductance case
- Fast & soft reverse recovery anti-parallel FWD
- Isolated copper baseplate using DBC technology

Typical Applications

- Inverter for motor drive
- AC and DC servo drive amplifier
- Uninterruptible power supply

IGBT-inverter $T_c=25^\circ\text{C}$ unless otherwise noted**Maximum Rated Values**

Symbol	Description	GD100PIY120C6SN	Units
V_{CES}	Collector-Emitter Voltage @ $T_j=25^\circ\text{C}$	1200	V
V_{GES}	Gate-Emitter Voltage @ $T_j=25^\circ\text{C}$	± 20	V
I_C	Collector Current @ $T_c=25^\circ\text{C}$ @ $T_c=100^\circ\text{C}$	155 100	A
I_{CM}	Pulsed Collector Current $t_p=1\text{ms}$	200	A
P_{tot}	Total Power Dissipation @ $T_j=175^\circ\text{C}$	508	W

Off Characteristics

Symbol	Parameter	Test Conditions	Min.	Typ.	Max.	Units
$V_{(BR)CES}$	Collector-Emitter Breakdown Voltage	$T_j=25^\circ\text{C}$	1200			V
I_{CES}	Collector Cut-Off Current	$V_{CE}=V_{CES}, V_{GE}=0\text{V},$ $T_j=25^\circ\text{C}$			1.0	mA
I_{GES}	Gate-Emitter Leakage Current	$V_{GE}=V_{GES}, V_{CE}=0\text{V},$ $T_j=25^\circ\text{C}$			100	nA

On Characteristics

Symbol	Parameter	Test Conditions	Min.	Typ.	Max.	Units
$V_{GE(th)}$	Gate-Emitter Threshold Voltage	$I_C=2.5\text{mA}, V_{CE}=V_{GE},$ $T_j=25^\circ\text{C}$	5.2	6.0	6.8	V
$V_{CE(sat)}$	Collector to Emitter Saturation Voltage	$I_C=100\text{A}, V_{GE}=15\text{V},$ $T_j=25^\circ\text{C}$		1.65	2.10	V
		$I_C=100\text{A}, V_{GE}=15\text{V},$ $T_j=125^\circ\text{C}$		1.95		

Switching Characteristics

Symbol	Parameter	Test Conditions	Min.	Typ.	Max.	Units	
$t_{d(on)}$	Turn-On Delay Time	$V_{CC}=600V, I_C=100A,$ $R_G=4.7\Omega, V_{GE}=\pm 15V,$ $T_j=25^\circ C$		280		ns	
t_r	Rise Time			54		ns	
$t_{d(off)}$	Turn-Off Delay Time			31		ns	
t_f	Fall Time			232		ns	
E_{on}	Turn-On Switching Loss				3.50		mJ
E_{off}	Turn-Off Switching Loss				7.35		mJ
$t_{d(on)}$	Turn-On Delay Time	$V_{CC}=600V, I_C=100A,$ $R_G=4.7\Omega, V_{GE}=\pm 15V,$ $T_j=125^\circ C$		281		ns	
t_r	Rise Time			56		ns	
$t_{d(off)}$	Turn-Off Delay Time			33		ns	
t_f	Fall Time			379		ns	
E_{on}	Turn-On Switching Loss				5.15		mJ
E_{off}	Turn-Off Switching Loss				11.3		mJ
C_{ies}	Input Capacitance	$V_{CE}=30V, f=1Mhz,$ $V_{GE}=0V$		9.10		nF	
C_{res}	Reverse Transfer Capacitance			0.28		nF	
Q_G	Gate Charge	$V_{CC}=600V, I_C=100A,$ $V_{GE}=15V$		0.60		μC	
R_{Gint}	Internal Gate Resistor			2.0		Ω	
I_{SC}	SC Data	$t_p \leq 10\mu s, V_{GE}=15V,$ $T_j=125^\circ C, V_{CC}=900V,$ $V_{CEM} \leq 1200V$		400		A	

Diode-inverter $T_C=25^\circ\text{C}$ unless otherwise noted**Maximum Rated Values**

Symbol	Description	GD100PIY120C6SN	Units
V_{RRM}	Repetitive Peak Reverse Voltage @ $T_j=25^\circ\text{C}$	1200	V
I_F	DC Forward Current	100	A
I_{FRM}	Repetitive Peak Forward Current $t_p=1\text{ms}$	200	A

Characteristics Values

Symbol	Parameter	Test Conditions	Min.	Typ.	Max.	Units
V_F	Diode Forward Voltage	$I_F=100\text{A}$, $V_{GE}=0\text{V}$	$T_j=25^\circ\text{C}$	1.70	2.10	V
			$T_j=125^\circ\text{C}$	1.65		
Q_r	Recovered Charge	$I_F=100\text{A}$, $V_R=600\text{V}$, $R_G=4.7\Omega$, $V_{GE}=-15\text{V}$	$T_j=25^\circ\text{C}$	7.7		μC
			$T_j=125^\circ\text{C}$	14.6		
I_{RM}	Peak Reverse Recovery Current	$I_F=100\text{A}$, $V_R=600\text{V}$, $R_G=4.7\Omega$, $V_{GE}=-15\text{V}$	$T_j=25^\circ\text{C}$	98		A
			$T_j=125^\circ\text{C}$	117		
E_{rec}	Reverse Recovery Energy	$I_F=100\text{A}$, $V_R=600\text{V}$, $R_G=4.7\Omega$, $V_{GE}=-15\text{V}$	$T_j=25^\circ\text{C}$	4.36		mJ
			$T_j=125^\circ\text{C}$	7.74		

Diode-rectifier $T_C=25^\circ\text{C}$ unless otherwise noted**Maximum Rated Values**

Symbol	Description	GD100PIY120C6SN	Units
V_{RRM}	Repetitive Peak Reverse Voltage @ $T_j=25^\circ\text{C}$	1600	V
I_F	DC Forward Current @ $T_C=80^\circ\text{C}$	100	A
I_{FSM}	Surge Forward Current $V_R=0\text{V}$, $t_p=10\text{ms}$, $T_j=45^\circ\text{C}$	1100	A
I^2t	I^2t -value, $V_R=0\text{V}$, $t_p=10\text{ms}$, $T_j=45^\circ\text{C}$	6050	A^2s

Characteristics Values

Symbol	Parameter	Test Conditions	Min.	Typ.	Max.	Units
V_F	Diode Forward Voltage	$I_F=100\text{A}$, $T_j=150^\circ\text{C}$		1.17		V
I_R	Reverse Current	$T_j=150^\circ\text{C}$, $V_R=1600\text{V}$			2.0	mA

IGBT-brake-chopper $T_C=25^\circ\text{C}$ unless otherwise noted**Maximum Rated Values**

Symbol	Description	GD100PIY120C6SN	Units
V_{CES}	Collector-Emitter Voltage @ $T_j=25^\circ\text{C}$	1200	V
V_{GES}	Gate-Emitter Voltage @ $T_j=25^\circ\text{C}$	± 20	V
I_C	Collector Current @ $T_C=25^\circ\text{C}$ @ $T_C=100^\circ\text{C}$	100 50	A
I_{CM}	Pulsed Collector Current $t_p=1\text{ms}$	100	A
P_{tot}	Total Power Dissipation @ $T_j=175^\circ\text{C}$	449	W

Off Characteristics

Symbol	Parameter	Test Conditions	Min.	Typ.	Max.	Units
$V_{(BR)CES}$	Collector-Emitter Breakdown Voltage	$T_j=25^\circ\text{C}$	1200			V
I_{CES}	Collector Cut-Off Current	$V_{CE}=V_{CES}, V_{GE}=0\text{V},$ $T_j=25^\circ\text{C}$			5.0	mA
I_{GES}	Gate-Emitter Leakage Current	$V_{GE}=V_{GES}, V_{CE}=0\text{V},$ $T_j=25^\circ\text{C}$			400	nA

On Characteristics

Symbol	Parameter	Test Conditions	Min.	Typ.	Max.	Units
$V_{GE(th)}$	Gate-Emitter Threshold Voltage	$I_C=2.0\text{mA}, V_{CE}=V_{GE},$ $T_j=25^\circ\text{C}$	5.0	6.2	7.0	V
$V_{CE(sat)}$	Collector to Emitter Saturation Voltage	$I_C=50\text{A}, V_{GE}=15\text{V},$ $T_j=25^\circ\text{C}$		1.85	2.30	V
		$I_C=50\text{A}, V_{GE}=15\text{V},$ $T_j=125^\circ\text{C}$		1.95		

Switching Characteristics

Symbol	Parameter	Test Conditions	Min.	Typ.	Max.	Units
$t_{d(on)}$	Turn-On Delay Time	$V_{CC}=600V, I_C=50A,$ $R_G=15\Omega, V_{GE}=\pm 15V,$ $T_j=25^\circ C$		392		ns
t_r	Rise Time			74		ns
$t_{d(off)}$	Turn-Off Delay Time			374		ns
t_f	Fall Time			380		ns
E_{on}	Turn-On Switching Loss			6.28		mJ
E_{off}	Turn-Off Switching Loss			3.22		mJ
$t_{d(on)}$	Turn-On Delay Time	$V_{CC}=600V, I_C=50A,$ $R_G=15\Omega, V_{GE}=\pm 15V,$ $T_j=125^\circ C$		403		ns
t_r	Rise Time			69		ns
$t_{d(off)}$	Turn-Off Delay Time			408		ns
t_f	Fall Time			381		ns
E_{on}	Turn-On Switching Loss			7.30		mJ
E_{off}	Turn-Off Switching Loss			5.22		mJ
C_{ies}	Input Capacitance	$V_{CE}=25V, f=1Mhz,$ $V_{GE}=0V$		4.29		nF
C_{res}	Reverse Transfer Capacitance			0.20		nF
Q_G	Gate Charge	$V_{CC}=600V, I_C=50A,$ $V_{GE}=-15 \dots +15V$		536		nC
R_{Gint}	Internal Gate Resistor			10		Ω
I_{SC}	SC Data	$t_p \leq 10\mu s, V_{GE}=15V,$ $T_j=125^\circ C, V_{CC}=900V,$ $V_{CEM} \leq 1200V$		270		A

Diode-brake-chopper $T_C=25^\circ C$ unless otherwise noted

Maximum Rated Values

Symbol	Description	GD100PIY120C6SN	Units
V_{RRM}	Repetitive Peak Reverse Voltage @ $T_j=25^\circ C$	1200	V
I_F	DC Forward Current	25	A
I_{FRM}	Repetitive Peak Forward Current $t_p=1ms$	50	A

Characteristics Values

Symbol	Parameter	Test Conditions	Min.	Typ.	Max.	Units
V_F	Diode Forward Voltage	$I_F=25A, V_{GE}=0V$	$T_j=25^\circ C$	1.78	2.18	V
			$T_j=125^\circ C$	1.88		
Q_r	Recovered Charge	$I_F=25A,$ $V_R=600V,$ $R_G=33\Omega,$ $V_{GE}=-15V$	$T_j=25^\circ C$	1.1		μC
			$T_j=125^\circ C$	3.2		
I_{RM}	Peak Reverse Recovery Current	$I_F=25A,$ $V_R=600V,$ $R_G=33\Omega,$ $V_{GE}=-15V$	$T_j=25^\circ C$	17		A
			$T_j=125^\circ C$	21		
E_{rec}	Reverse Recovery Energy	$I_F=25A,$ $V_R=600V,$ $R_G=33\Omega,$ $V_{GE}=-15V$	$T_j=25^\circ C$	0.80		mJ
			$T_j=125^\circ C$	1.38		

Electrical Characteristics of NTC $T_C=25^{\circ}\text{C}$ unless otherwise noted

Symbol	Parameter	Test Conditions	Min.	Typ.	Max.	Units
R_{25}	Rated Resistance			5.0		k Ω
$\Delta R/R$	Deviation of R_{100}	$T_C=100^{\circ}\text{C}, R_{100}=493.3\Omega$	-5		5	%
P_{25}	Power Dissipation				20.0	mW
$B_{25/50}$	B-value	$R_2=R_{25}\exp[B_{25/50}(1/T_2-1/(298.15\text{K}))]$		3375		K

IGBT Module

Symbol	Parameter	Min.	Typ.	Max.	Units
V_{ISO}	Isolation Voltage RMS, $f=50\text{Hz}, t=1\text{min}$	4000			V
L_{CE}	Stray Inductance		40		nH
$R_{\theta\text{JC}}$	Junction-to-Case (per IGBT-inverter)			0.295	K/W
	Junction-to-Case (per Diode-inverter)			0.505	
	Junction-to-Case (per Diode-rectifier)			0.560	
	Junction-to-Case (per IGBT-brake-chopper)			0.334	
	Junction-to-Case (per Diode-brake-chopper)			0.946	
$R_{\theta\text{CS}}$	Case-to-Sink (per IGBT-inverter)		0.125		K/W
	Case-to-Sink (per Diode-inverter)		0.214		
	Case-to-Sink (per Diode-rectifier)		0.237		
	Case-to-Sink (per IGBT-brake-chopper)		0.141		
	Case-to-Sink (per Diode-brake-chopper)		0.400		
$R_{\theta\text{CS}}$	Case-to-Sink (Conductive grease applied)		0.009		K/W
T_{jmax}	Maximum Junction Temperature (inverter,brake)			175	$^{\circ}\text{C}$
	Maximum Junction Temperature(rectifier)			150	$^{\circ}\text{C}$
T_{jop}	Operating Junction Temperature	-40		150	$^{\circ}\text{C}$
T_{STG}	Storage Temperature Range	-40		125	$^{\circ}\text{C}$
M	Mounting Torque, Screw:M5	3.0		6.0	N.m
G	Weight of Module		300		g

Equivalent Circuit Schematic

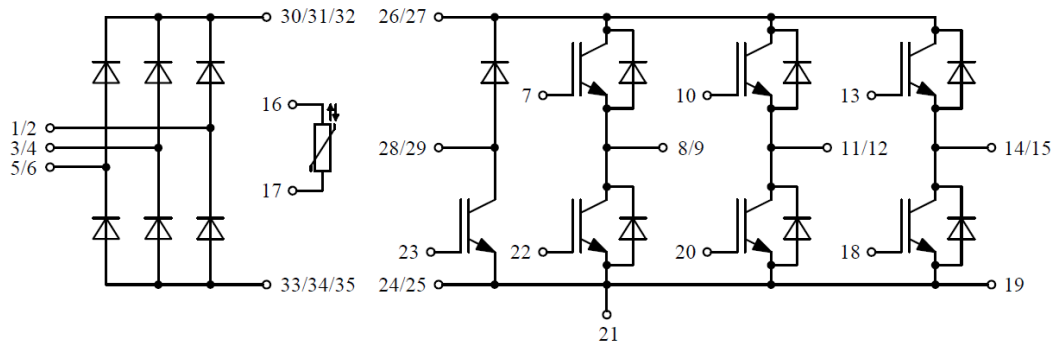

Package Dimensions

Dimensions in Millimeters

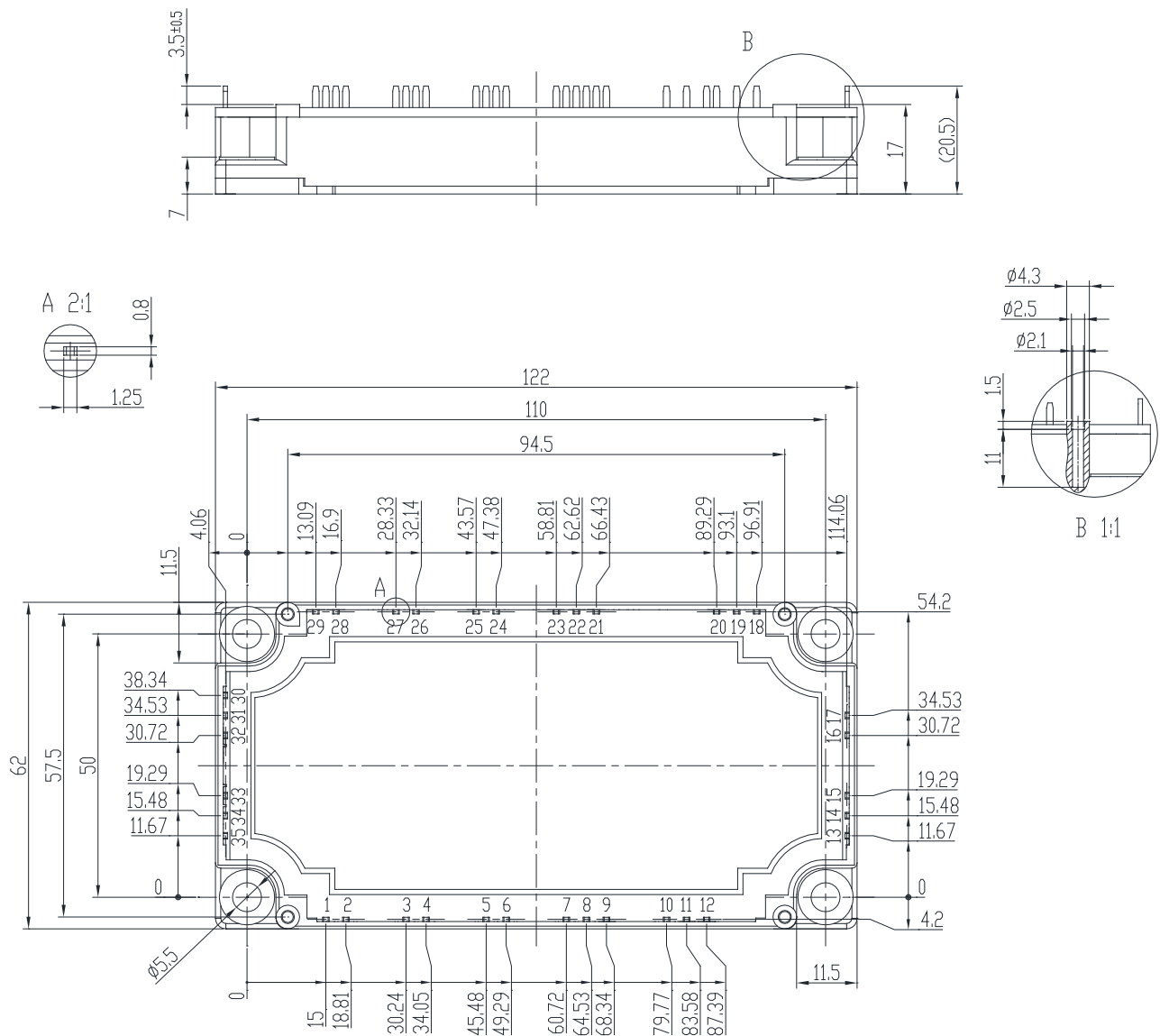

Terms and Conditions of Usage

The data contained in this product datasheet is exclusively intended for technically trained staff. you and your technical departments will have to evaluate the suitability of the product for the intended application and the completeness of the product data with respect to such application.

This product data sheet is describing the characteristics of this product for which a warranty is granted. Any such warranty is granted exclusively pursuant the terms and conditions of the supply agreement. There will be no guarantee of any kind for the product and its characteristics.

Should you require product information in excess of the data given in this product data sheet or which concerns the specific application of our product, please contact the sales office, which is responsible for you (see www.powersemi.cc), For those that are specifically interested we may provide application notes.

Due to technical requirements our product may contain dangerous substances. For information on the types in question please contact the sales office, which is responsible for you.

Should you intend to use the Product in aviation applications, in health or live endangering or life support applications, please notify.

If and to the extent necessary, please forward equivalent notices to your customers.
Changes of this product data sheet are reserved.

单击下面可查看定价，库存，交付和生命周期等信息

[>>STARPOWER\(斯达\)](#)