



STVVGLNA

General-purpose, variable-gain, low-noise, RF amplifier for broadcast receiver applications

Data brief

Features

- 75-Ω single-ended input impedance
- 75-Ω single-ended or 150-Ω differential output impedance
- Dual differential or single-ended outputs
- Single 3.3-V DC supply
- Input frequency range 50 to 2150 MHz
- Fully integrated RF AGC with power monitoring
- Low external component count
- Low power consumption (145 mW typical)
- Temperature range -35 °C to 85 °C
- Compatible with 5-V and 3.3-V I²C bus
- I²C bus control (option)
- Four selectable I²C addresses C8,CA,CC,CE

Applications

- Satellite set-top boxes
- SMATV RF accessories
- LNBS
- DVB-T active indoor antennas

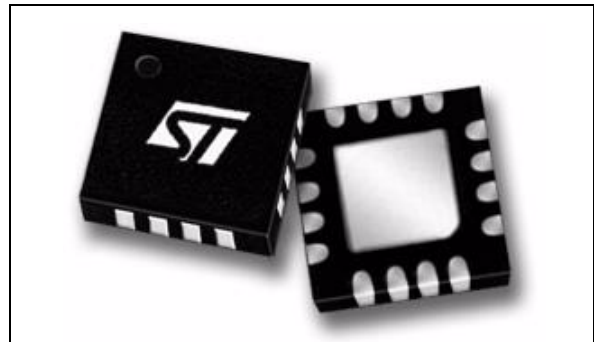

Package

- VFQFPN-16L 3x3x0.85 mm³ with exposed pad down (EPD)
- Environmentally friendly packaging, RoHS (2002/95/EC) compliant.

Description

The STVVGLNA is a general-purpose, low-noise amplifier with a gain range of -17 dB to +15 dB. Its gain is regulated either autonomously by an integrated AGC loop or by software control.

It can be used, for example, as an input amplifier for a satellite set-top box.

Figure 1. STVVGLNA block diagram

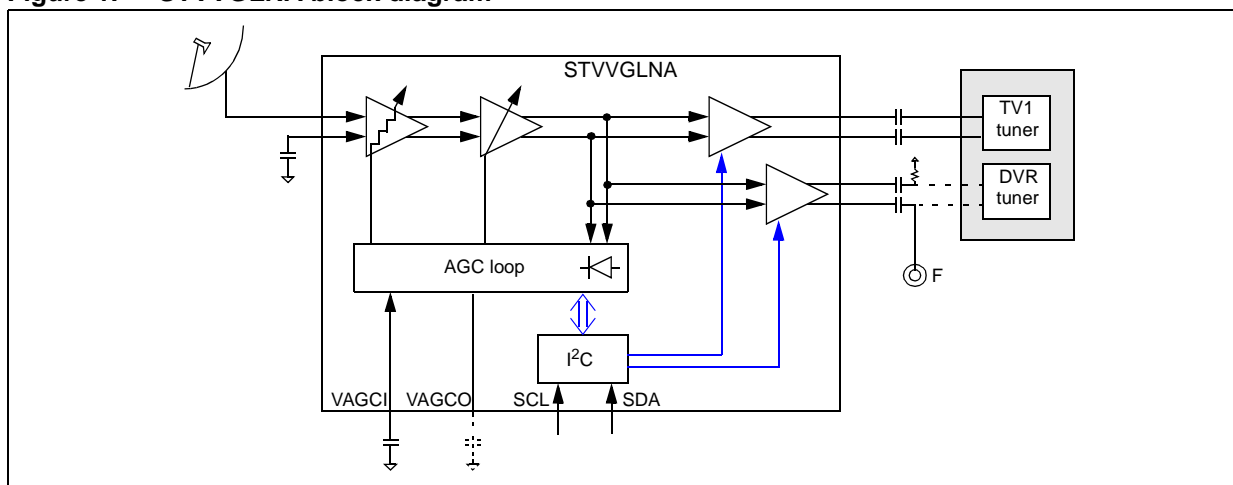

1 Introduction

The STVVGLNA is a front-stage amplifier designed for set-top boxes. It has high input power dynamic range to allow the optimization of sensitivity and linearity requirements.

The STVVGLNA has several operating modes suitable for different signal conditions:

- automatic wide-band mode, internal AGC (the default mode)
- semi-automatic wide-band mode, internal AGC
- fixed gain mode, no AGC
- variable gain with external AGC (driven by demodulator, for example)

The mode of operation is programmable via the I²C bus.

The STVVGLNA also provides a RF-signal-level indication which may be interrogated via the I²C bus. This is useful for installation and status information.

At power-on, the STVVGLNA starts in automatic and autonomous AGC mode so that it can operate in satellite set-top boxes, LNBs or SMATV accessories without any software assistance.

Features	Benefits
Active amplitude compensation and balanced/differential operation.	Simplified RF layout and increased robustness to interference.
Four AGC/Gain programmable operating modes.	Flexible AGC strategy.
Programmable via I2C bus.	The device can be μ P controlled.
Wide range of input frequencies.	Applications range from satellite receivers down to VHF antenna amplifiers.
Low component count plus tiny package with exposed pad.	Small BOM and minimal use of PCB area.
Pre programmed automatic wide-band internal AGC mode.	No micro processor is required if the STVVGLNA is to be used in default mode.

2 Ordering information

Table 1. Device summary

Order code	Temperature range	Package	Packaging
STVVGLNA	-35 to 85 °C	VFQFPN-16L EPD	Tray
STVVGLNAT	-35 to 85 °C	VFQFPN-16L EPD	Reel

3 Revision history

Table 2. Document revision history

Date	Revision	Changes
01-Jun-2011	1	Initial release.

Please Read Carefully:

Information in this document is provided solely in connection with ST products. STMicroelectronics NV and its subsidiaries ("ST") reserve the right to make changes, corrections, modifications or improvements, to this document, and the products and services described herein at any time, without notice.

All ST products are sold pursuant to ST's terms and conditions of sale.

Purchasers are solely responsible for the choice, selection and use of the ST products and services described herein, and ST assumes no liability whatsoever relating to the choice, selection or use of the ST products and services described herein.

No license, express or implied, by estoppel or otherwise, to any intellectual property rights is granted under this document. If any part of this document refers to any third party products or services it shall not be deemed a license grant by ST for the use of such third party products or services, or any intellectual property contained therein or considered as a warranty covering the use in any manner whatsoever of such third party products or services or any intellectual property contained therein.

UNLESS OTHERWISE SET FORTH IN ST'S TERMS AND CONDITIONS OF SALE ST DISCLAIMS ANY EXPRESS OR IMPLIED WARRANTY WITH RESPECT TO THE USE AND/OR SALE OF ST PRODUCTS INCLUDING WITHOUT LIMITATION IMPLIED WARRANTIES OF MERCHANTABILITY, FITNESS FOR A PARTICULAR PURPOSE (AND THEIR EQUIVALENTS UNDER THE LAWS OF ANY JURISDICTION), OR INFRINGEMENT OF ANY PATENT, COPYRIGHT OR OTHER INTELLECTUAL PROPERTY RIGHT.

UNLESS EXPRESSLY APPROVED IN WRITING BY AN AUTHORIZED ST REPRESENTATIVE, ST PRODUCTS ARE NOT RECOMMENDED, AUTHORIZED OR WARRANTED FOR USE IN MILITARY, AIR CRAFT, SPACE, LIFE SAVING, OR LIFE SUSTAINING APPLICATIONS, NOR IN PRODUCTS OR SYSTEMS WHERE FAILURE OR MALFUNCTION MAY RESULT IN PERSONAL INJURY, DEATH, OR SEVERE PROPERTY OR ENVIRONMENTAL DAMAGE. ST PRODUCTS WHICH ARE NOT SPECIFIED AS "AUTOMOTIVE GRADE" MAY ONLY BE USED IN AUTOMOTIVE APPLICATIONS AT USER'S OWN RISK.

Resale of ST products with provisions different from the statements and/or technical features set forth in this document shall immediately void any warranty granted by ST for the ST product or service described herein and shall not create or extend in any manner whatsoever, any liability of ST.

ST and the ST logo are trademarks or registered trademarks of ST in various countries.

Information in this document supersedes and replaces all information previously supplied.

The ST logo is a registered trademark of STMicroelectronics. All other names are the property of their respective owners.

© 2011 STMicroelectronics - All rights reserved

STMicroelectronics group of companies

Australia - Belgium - Brazil - Canada - China - Czech Republic - Finland - France - Germany - Hong Kong - India - Israel - Italy - Japan - Malaysia - Malta - Morocco - Philippines - Singapore - Spain - Sweden - Switzerland - United Kingdom - United States of America

www.st.com

单击下面可查看定价，库存，交付和生命周期等信息

[>>STMicro\(意法半导体\)](#)