

## N-channel 650 V, 0.60 $\Omega$ typ., 7 A MDmesh™ M2 Power MOSFET in DPAK, TO-220 and IPAK packages

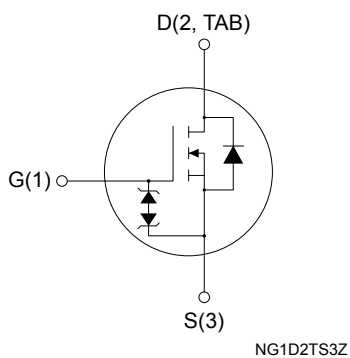
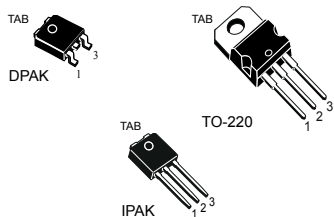

### Features

Order code	$V_{DS}$	$R_{DS(on)}$ max.	$I_D$	$P_{TOT}$	Package
STD11N65M2	650 V	0.68 $\Omega$	7 A	85 W	DPAK
STP11N65M2					TO-220
STU11N65M2					IPAK

- Extremely low gate charge
- Excellent output capacitance ( $C_{OSS}$ ) profile
- 100% avalanche tested
- Zener-protected

### Applications

- Switching applications

### Description

These devices are N-channel Power MOSFETs developed using the MDmesh M2 technology. Thanks to their strip layout and improved vertical structure, these devices exhibit low on-resistance and optimized switching characteristics, rendering them suitable for the most demanding high-efficiency converters.



#### Product status link

[STD11N65M2](#)
[STP11N65M2](#)
[STU11N65M2](#)

# 1 Electrical ratings

**Table 1. Absolute maximum ratings**

Symbol	Parameter	Value	Unit
$V_{GS}$	Gate-source voltage	$\pm 25$	V
$I_D$	Drain current (continuous) at $T_{case} = 25\text{ }^\circ\text{C}$	7	A
	Drain current (continuous) at $T_{case} = 100\text{ }^\circ\text{C}$	4.4	
$I_{DM}^{(1)}$	Drain current (pulsed)	28	A
$P_{TOT}$	Total power dissipation at $T_{case} = 25\text{ }^\circ\text{C}$	85	W
$dv/dt^{(2)}$	Peak diode recovery voltage slope	15	V/ns
$dv/dt^{(3)}$	MOSFET $dv/dt$ ruggedness	50	
$T_{stg}$	Storage temperature range	-55 to 150	$^\circ\text{C}$
$T_j$	Operating junction temperature range		

1. Pulse width limited by  $T_{jmax}$ .
2.  $I_{SD} \leq 7\text{ A}$ ,  $di/dt \leq 400\text{ A}/\mu\text{s}$ ,  $V_{DS} (\text{peak}) \leq V_{(BR)DSS}$ ,  $V_{DS} = 400\text{ V}$
3.  $V_{DS} \leq 520\text{ V}$ .

**Table 2. Thermal data**

Symbol	Parameter	Value			Unit
		DPAK	TO-220	IPAK	
$R_{thj-case}$	Thermal resistance junction-case	1.47			$^\circ\text{C}/\text{W}$
$R_{thj-amb}$	Thermal resistance junction-ambient		62.5	100	
$R_{thj-pcb}^{(1)}$	Thermal resistance junction-pcb	50			

1. When mounted on a 1-inch<sup>2</sup> FR-4, 2 Oz copper board.

**Table 3. Avalanche characteristics**

Symbol	Parameter	Value	Unit
$I_{AR}^{(1)}$	Avalanche current, repetitive or not repetitive	1.5	A
$E_{AS}^{(2)}$	Single pulse avalanche energy	110	mJ

1. Pulse width limited by  $T_{jmax}$ .
2. starting  $T_j = 25\text{ }^\circ\text{C}$ ,  $I_D = I_{AR}$ ,  $V_{DD} = 50\text{ V}$ .

## 2 Electrical characteristics

( $T_{\text{case}} = 25\text{ }^{\circ}\text{C}$  unless otherwise specified)

**Table 4. Static**

Symbol	Parameter	Test conditions	Min.	Typ.	Max.	Unit
$V_{(\text{BR})\text{DSS}}$	Drain-source breakdown voltage	$V_{\text{GS}} = 0\text{ V}$ , $I_{\text{D}} = 1\text{ mA}$	650			V
$I_{\text{DSS}}$	Zero gate voltage drain current	$V_{\text{GS}} = 0\text{ V}$ , $V_{\text{DS}} = 650\text{ V}$			1	$\mu\text{A}$
		$V_{\text{GS}} = 0\text{ V}$ , $V_{\text{DS}} = 650\text{ V}$ , $T_{\text{case}} = 125\text{ }^{\circ}\text{C}^{(1)}$			100	
$I_{\text{GSS}}$	Gate-body leakage current	$V_{\text{DS}} = 0\text{ V}$ , $V_{\text{GS}} = \pm 25\text{ V}$			$\pm 10$	$\mu\text{A}$
$V_{\text{GS}(\text{th})}$	Gate threshold voltage	$V_{\text{DS}} = V_{\text{GS}}$ , $I_{\text{D}} = 250\text{ }\mu\text{A}$	2	3	4	V
$R_{\text{DS}(\text{on})}$	Static drain-source on-resistance	$V_{\text{GS}} = 10\text{ V}$ , $I_{\text{D}} = 3.5\text{ A}$		0.60	0.68	$\Omega$

1. Defined by design, not subject to production test.

**Table 5. Dynamic**

Symbol	Parameter	Test conditions	Min.	Typ.	Max.	Unit
$C_{\text{iSS}}$	Input capacitance	$V_{\text{DS}} = 100\text{ V}$ , $f = 1\text{ MHz}$ , $V_{\text{GS}} = 0\text{ V}$	-	410	-	$\text{pF}$
$C_{\text{oSS}}$	Output capacitance		-	20	-	
$C_{\text{rSS}}$	Reverse transfer capacitance		-	0.9	-	
$C_{\text{oSS eq.}}^{(1)}$	Equivalent output capacitance	$V_{\text{DS}} = 0\text{ to }520\text{ V}$ , $V_{\text{GS}} = 0\text{ V}$	-	43	-	$\text{pF}$
$R_{\text{G}}$	Intrinsic gate resistance	$f = 1\text{ MHz}$ , $I_{\text{D}} = 0\text{ A}$	-	6.4	-	$\Omega$
$Q_{\text{g}}$	Total gate charge	$V_{\text{DD}} = 520\text{ V}$ , $I_{\text{D}} = 7\text{ A}$ , $V_{\text{GS}} = 0\text{ to }10\text{ V}$ (see Figure 16)	-	12.5	-	$\text{nC}$
$Q_{\text{gs}}$	Gate-source charge		-	3.2	-	
$Q_{\text{gd}}$	Gate-drain charge		-	5.8	-	

1.  $C_{\text{oSS eq.}}$  is defined as a constant equivalent capacitance giving the same charging time as  $C_{\text{oSS}}$  when  $V_{\text{DS}}$  increases from 0 to 80%  $V_{\text{DSS}}$ .

**Table 6. Switching times**

Symbol	Parameter	Test conditions	Min.	Typ.	Max.	Unit
$t_{\text{d}(\text{on})}$	Turn-on delay time	$V_{\text{DD}} = 325\text{ V}$ , $I_{\text{D}} = 3.5\text{ A}$ , $R_{\text{G}} = 4.7\text{ }\Omega$ , $V_{\text{GS}} = 10\text{ V}$ (see Figure 15 and Figure 20)	-	9.5	-	$\text{ns}$
$t_{\text{r}}$	Rise time		-	7.5	-	
$t_{\text{d}(\text{off})}$	Turn-off delay time		-	26	-	
$t_{\text{f}}$	Fall time		-	15	-	

**Table 7. Source-drain diode**

Symbol	Parameter	Test conditions	Min.	Typ.	Max.	Unit
$I_{SD}$	Source-drain current		-		7	A
$I_{SDM}^{(1)}$	Source-drain current (pulsed)		-		28	A
$V_{SD}^{(2)}$	Forward on voltage	$V_{GS} = 0\text{ V}$ , $I_{SD} = 7\text{ A}$	-		1.6	V
$t_{rr}$	Reverse recovery time	$I_{SD} = 7\text{ A}$ , $di/dt = 100\text{ A}/\mu\text{s}$ , $V_{DD} = 60\text{ V}$ (see Figure 17)	-	318		ns
$Q_{rr}$	Reverse recovery charge		-	2.5		$\mu\text{C}$
$I_{RRM}$	Reverse recovery current		-	15.5		A
$t_{rr}$	Reverse recovery time	$I_{SD} = 7\text{ A}$ , $di/dt = 100\text{ A}/\mu\text{s}$ , $V_{DD} = 60\text{ V}$ , $T_j = 150\text{ }^\circ\text{C}$ (see Figure 17)	-	437		ns
$Q_{rr}$	Reverse recovery charge		-	3.2		$\mu\text{C}$
$I_{RRM}$	Reverse recovery current		-	15		A

1. Pulse width is limited by safe operating area.

2. Pulse test: pulse duration = 300  $\mu\text{s}$ , duty cycle 1.5%.

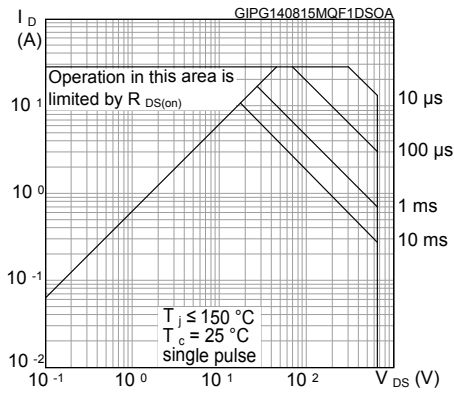
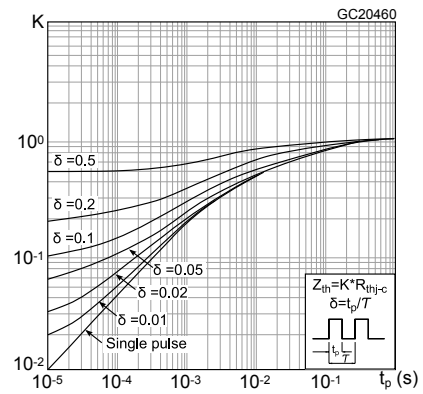
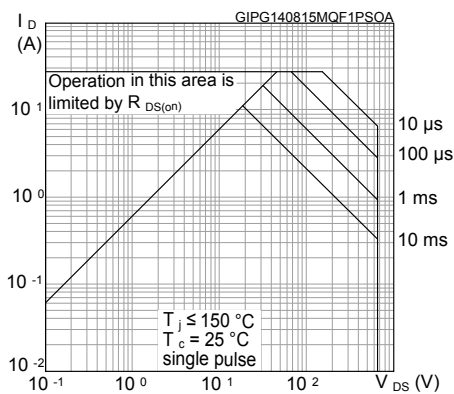
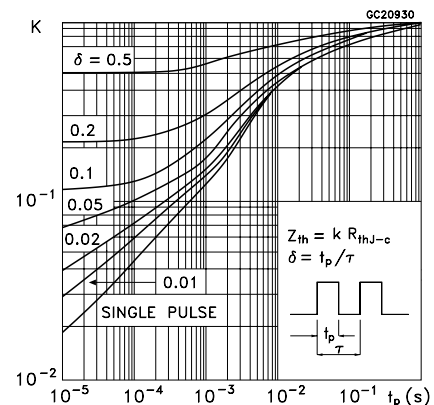
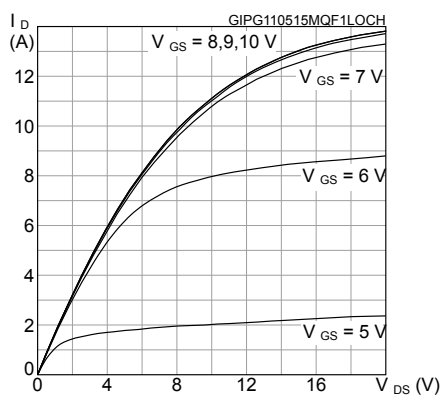
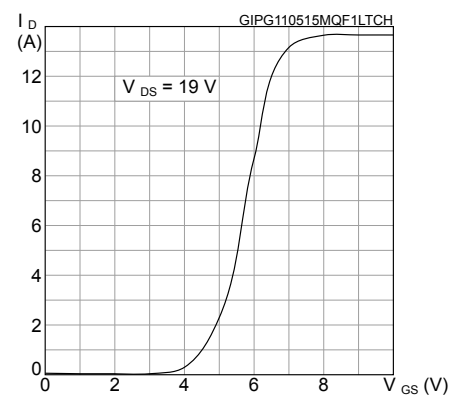
**2.1 Electrical characteristics (curves)**
**Figure 1. Safe operating area for DPAK and IPAK**

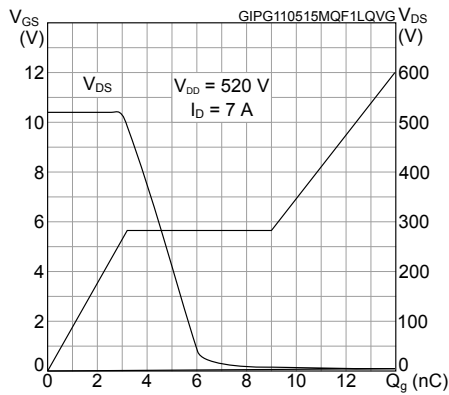
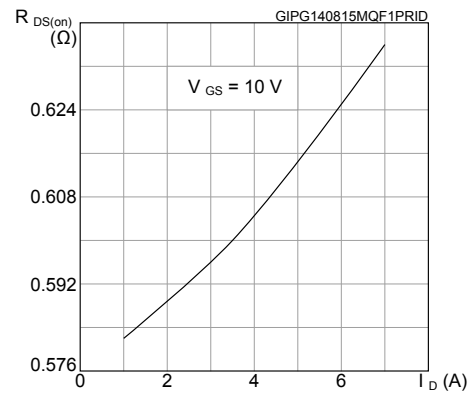
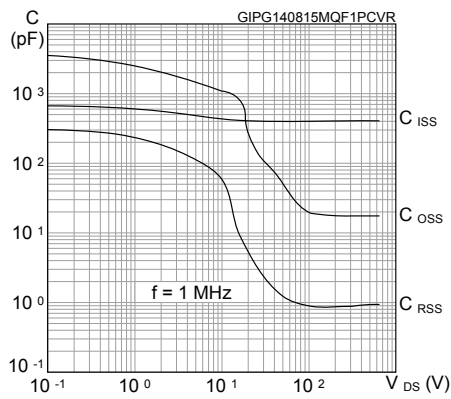
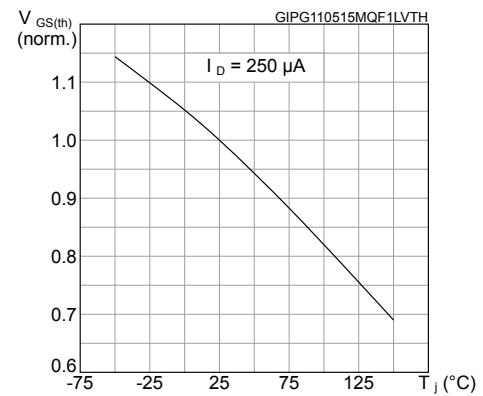
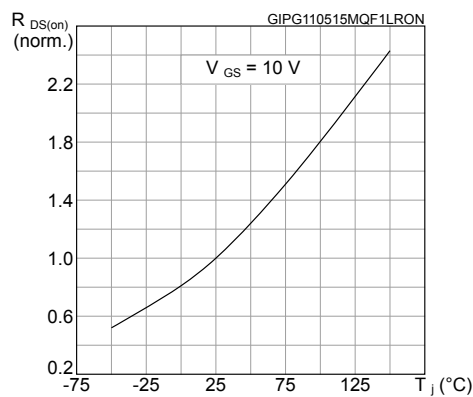
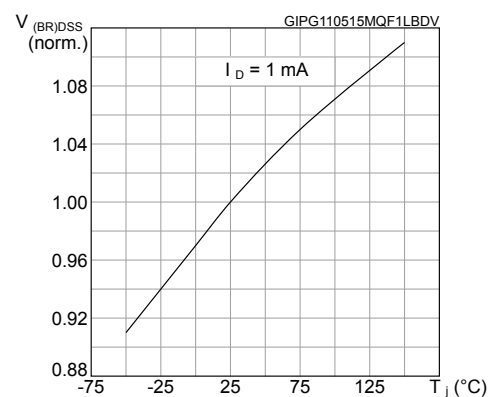
**Figure 2. Thermal impedance for DPAK and IPAK**

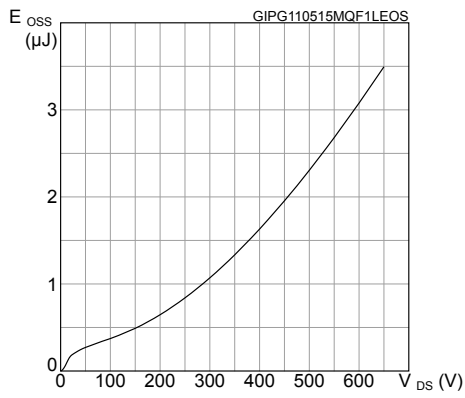
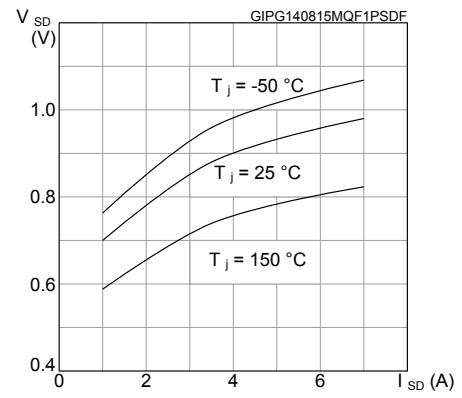
**Figure 3. Safe operating area for TO-220**

**Figure 4. Thermal impedance for TO-220**

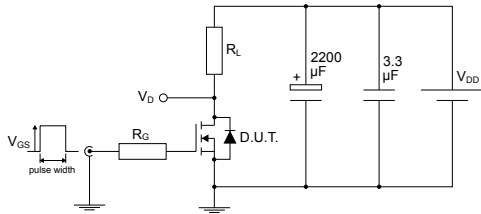
**Figure 5. Output characteristics**

**Figure 6. Transfer characteristics**

**Figure 7. Gate charge vs gate-source voltage**

**Figure 8. Static drain-source on-resistance**

**Figure 9. Capacitance variations**

**Figure 10. Normalized gate threshold voltage vs temperature**

**Figure 11. Normalized on-resistance vs temperature**

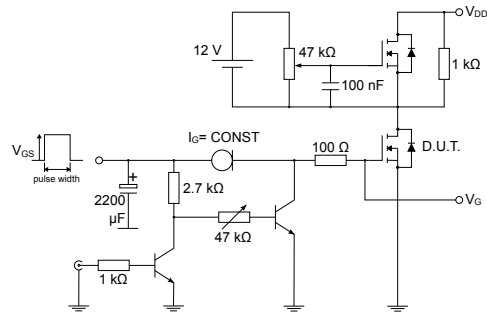
**Figure 12. Normalized V(BR)DSS vs temperature**

**Figure 13. Output capacitance stored energy**

**Figure 14. Source-drain diode forward characteristics**

### 3 Test circuits

**Figure 15. Test circuit for resistive load switching times**

AM01468v1

**Figure 16. Test circuit for gate charge behavior**

AM01469v1

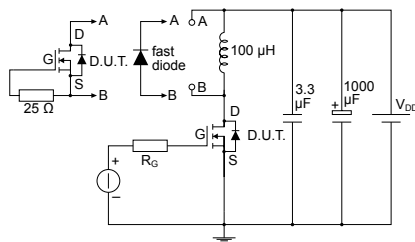
**Figure 17. Test circuit for inductive load switching and diode recovery times**

AM01470v1

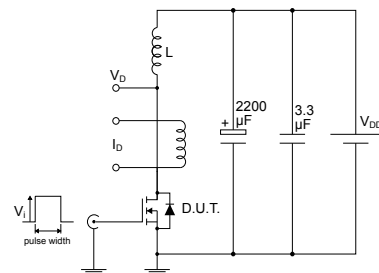
**Figure 18. Unclamped inductive load test circuit**

AM01471v1

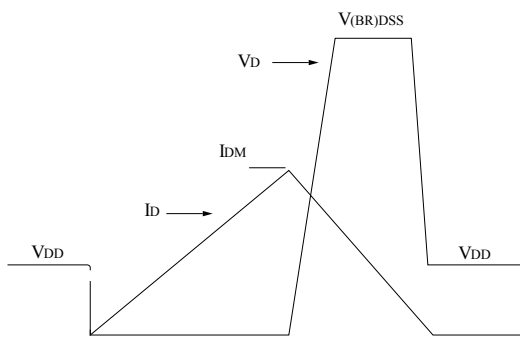
**Figure 19. Unclamped inductive waveform**

AM01472v1

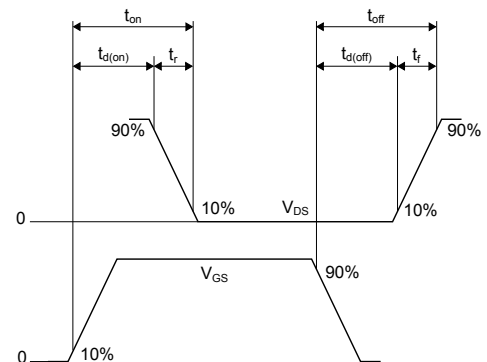
**Figure 20. Switching time waveform**

AM01473v1



## 4 Package information

---

In order to meet environmental requirements, ST offers these devices in different grades of **ECOPACK** packages, depending on their level of environmental compliance. ECOPACK specifications, grade definitions and product status are available at: [www.st.com](http://www.st.com). ECOPACK is an ST trademark.

### 4.1 DPAK (TO-252) type A package information

Figure 21. DPAK (TO-252) type A package outline

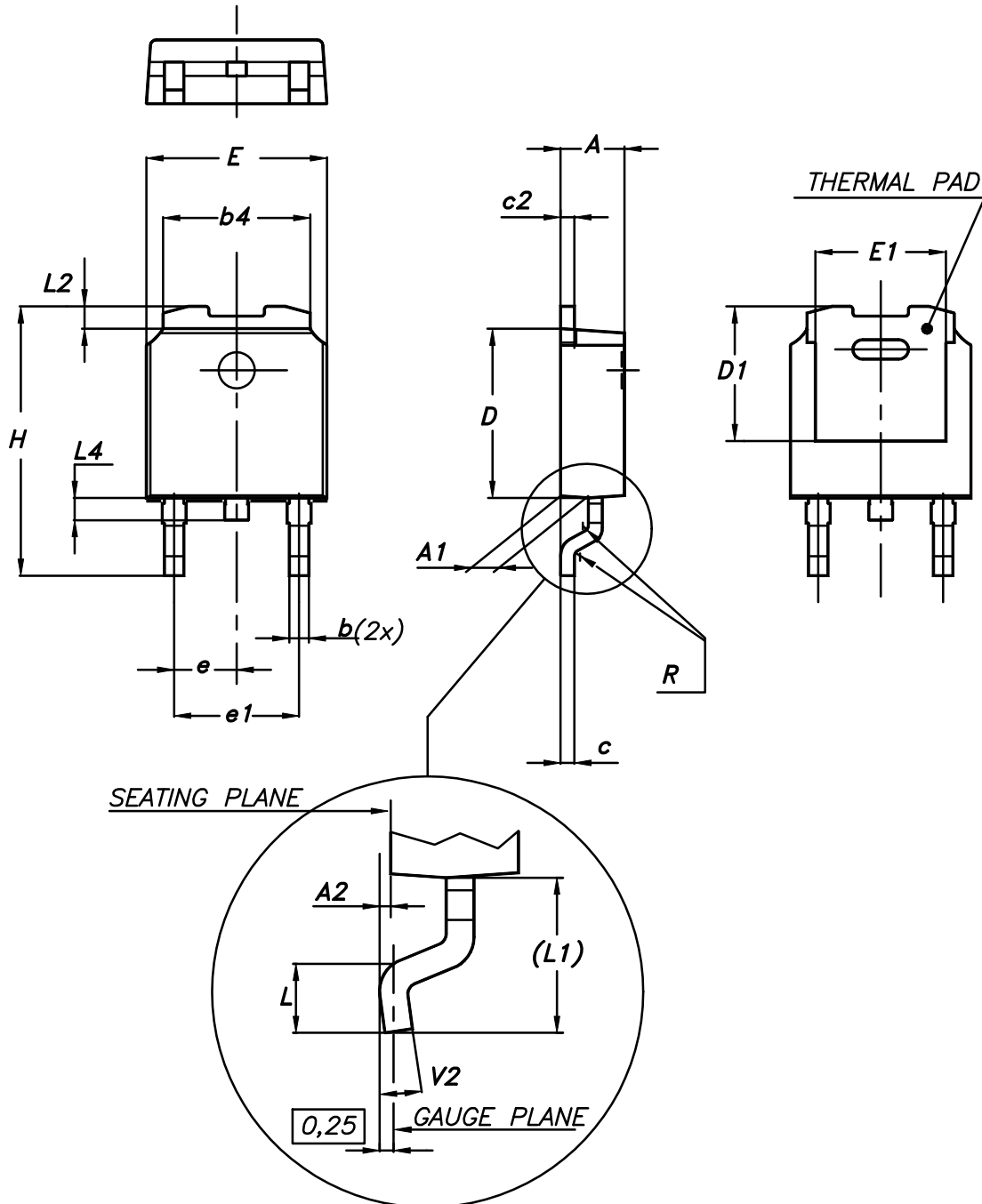

0068772\_A\_26

**Table 8. DPAK (TO-252) type A mechanical data**

Dim.	mm		
	Min.	Typ.	Max.
A	2.20		2.40
A1	0.90		1.10
A2	0.03		0.23
b	0.64		0.90
b4	5.20		5.40
c	0.45		0.60
c2	0.48		0.60
D	6.00		6.20
D1	4.95	5.10	5.25
E	6.40		6.60
E1	4.60	4.70	4.80
e	2.159	2.286	2.413
e1	4.445	4.572	4.699
H	9.35		10.10
L	1.00		1.50
(L1)	2.60	2.80	3.00
L2	0.65	0.80	0.95
L4	0.60		1.00
R		0.20	
V2	0°		8°

## 4.2 DPAK (TO-252) type C package information

Figure 22. DPAK (TO-252) type C package outline

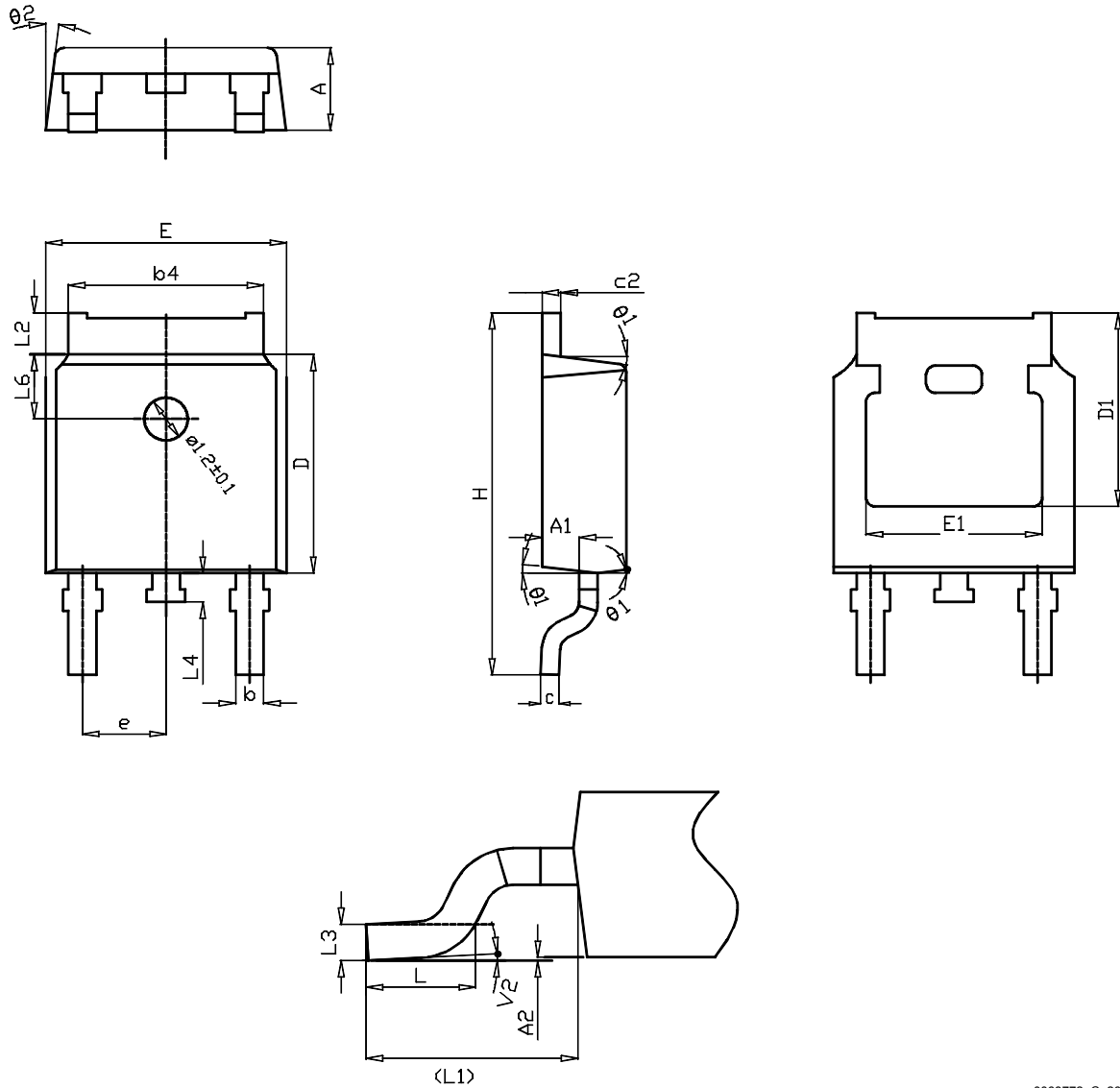

0068772\_C\_26

Table 9. DPAK (TO-252) type C mechanical data

Dim.	mm		
	Min.	Typ.	Max.
A	2.20	2.30	2.38
A1	0.90	1.01	1.10
A2	0.00		0.10
b	0.72		0.85
b4	5.13	5.33	5.46
c	0.47		0.60
c2	0.47		0.60
D	6.00	6.10	6.20
D1	5.25		
E	6.50	6.60	6.70
E1	4.70		
e	2.186	2.286	2.386
H	9.80	10.10	10.40
L	1.40	1.50	1.70
L1	2.90 REF		
L2	0.90		1.25
L3	0.51 BSC		
L4	0.60	0.80	1.00
L6	1.80 BSC		
θ1	5°	7°	9°
θ2	5°	7°	9°
V2	0°		8°

### 4.3 DPAK (TO-252) type E package information

Figure 23. DPAK (TO-252) type E package outline

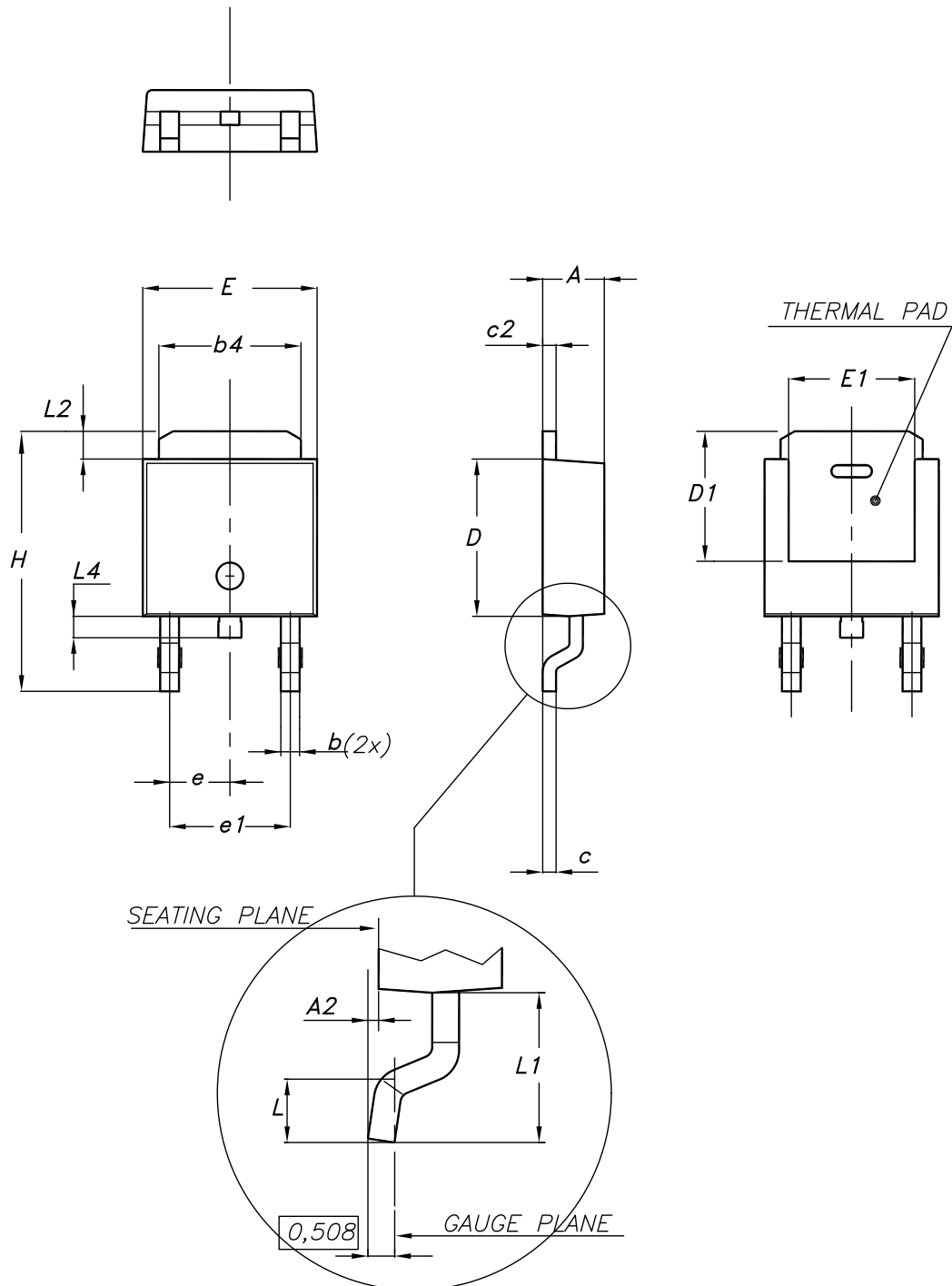

0068772\_type-E\_rev.26

Table 10. DPAK (TO-252) type E mechanical data

Dim.	mm		
	Min.	Typ.	Max.
A	2.18		2.39
A2			0.13
b	0.65		0.884
b4	4.95		5.46
c	0.46		0.61
c2	0.46		0.60
D	5.97		6.22
D1	5.21		
E	6.35		6.73
E1	4.32		
e		2.286	
e1		4.572	
H	9.94		10.34
L	1.50		1.78
L1		2.74	
L2	0.89		1.27
L4			1.02

Figure 24. DPAK (TO-252) recommended footprint (dimensions are in mm)

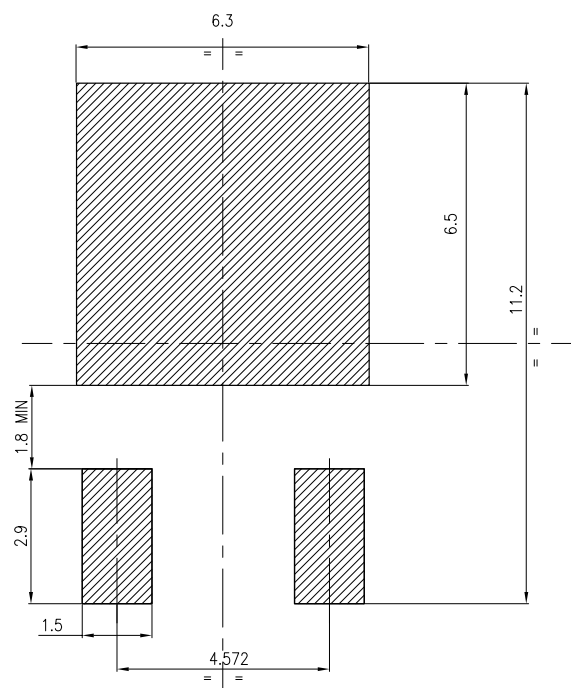

FP\_0068772\_26

#### 4.4 DPAK (TO-252) packing information

Figure 25. DPAK (TO-252) tape outline

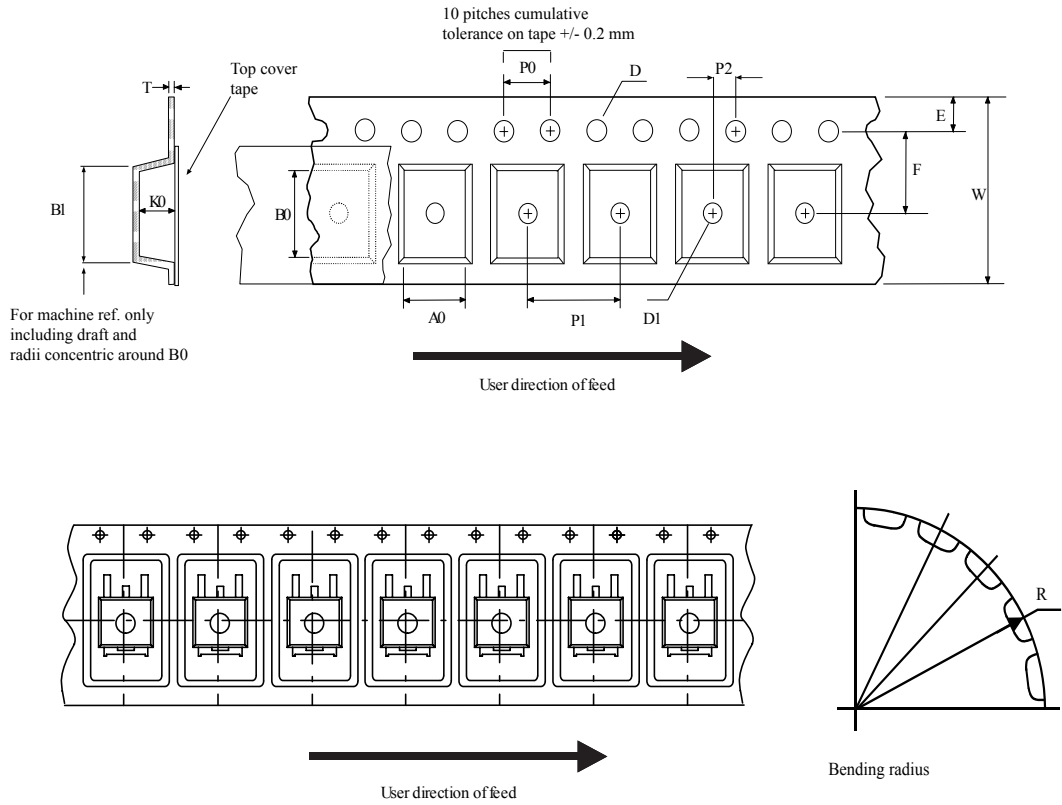

AM08852v1



Figure 26. DPAK (TO-252) reel outline

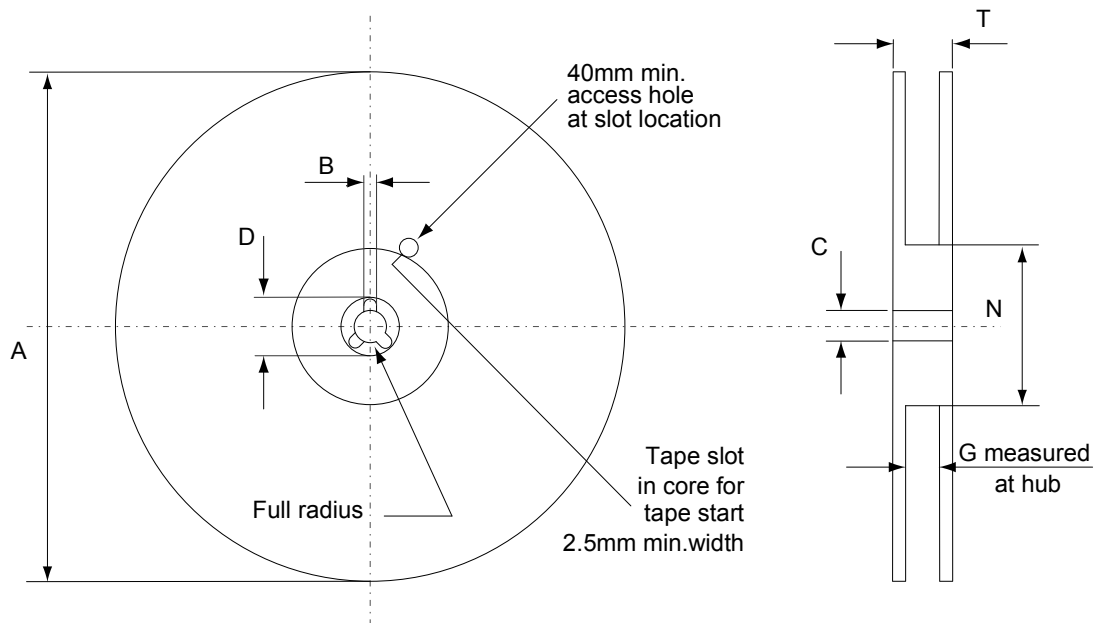

AM06038v1

Table 11. DPAK (TO-252) tape and reel mechanical data

Tape			Reel		
Dim.	mm		Dim.	mm	
	Min.	Max.		Min.	Max.
A0	6.8	7	A		330
B0	10.4	10.6	B	1.5	
B1		12.1	C	12.8	13.2
D	1.5	1.6	D	20.2	
D1	1.5		G	16.4	18.4
E	1.65	1.85	N	50	
F	7.4	7.6	T		22.4
K0	2.55	2.75			
P0	3.9	4.1		Base qty.	2500
P1	7.9	8.1		Bulk qty.	2500
P2	1.9	2.1			
R	40				
T	0.25	0.35			
W	15.7	16.3			

### 4.5 TO-220 type A package information

Figure 27. TO-220 type A package outline

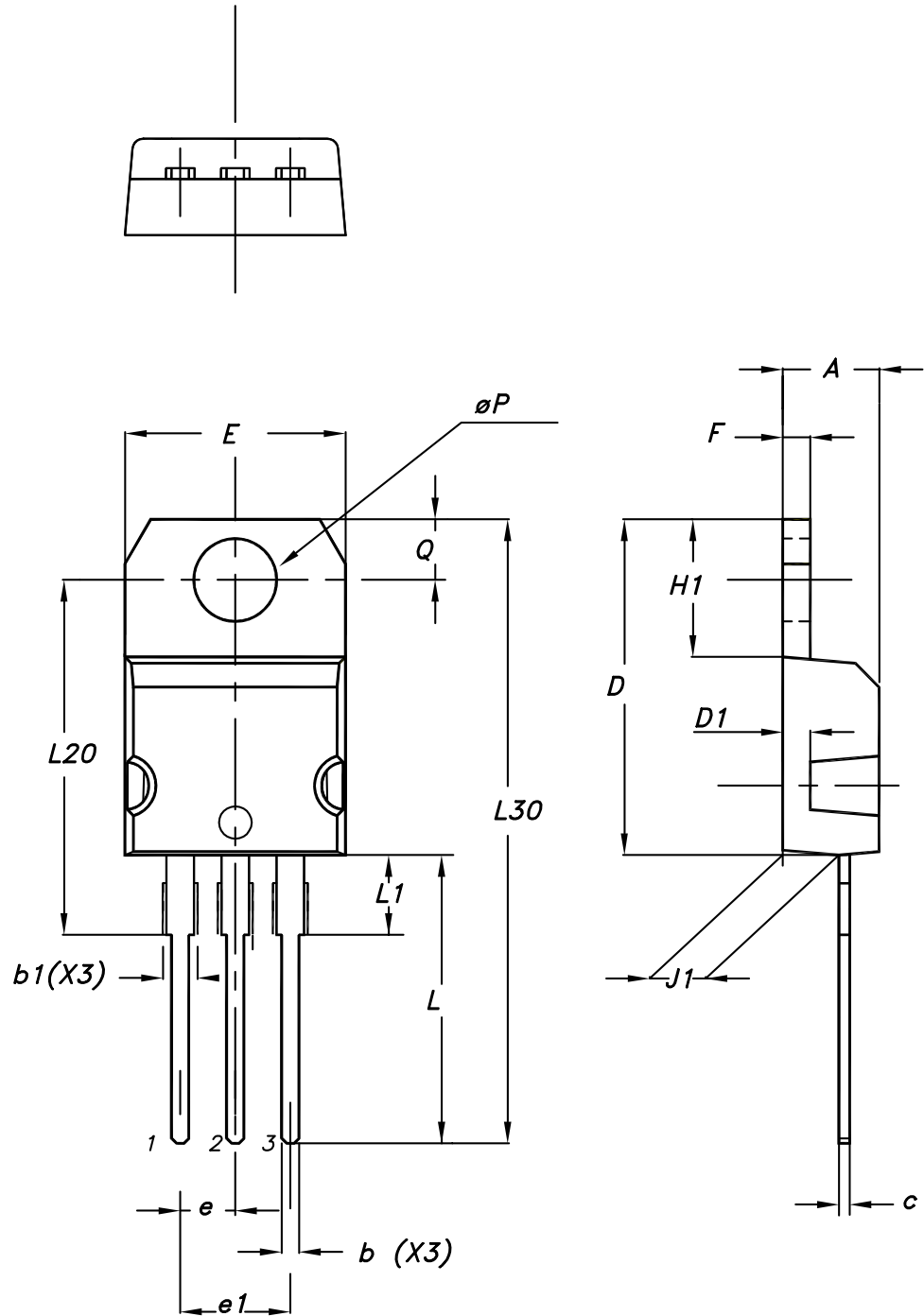

0015988\_typeA\_Rev\_22

**Table 12. TO-220 type A package mechanical data**

Dim.	mm		
	Min.	Typ.	Max.
A	4.40		4.60
b	0.61		0.88
b1	1.14		1.55
c	0.48		0.70
D	15.25		15.75
D1		1.27	
E	10.00		10.40
e	2.40		2.70
e1	4.95		5.15
F	1.23		1.32
H1	6.20		6.60
J1	2.40		2.72
L	13.00		14.00
L1	3.50		3.93
L20		16.40	
L30		28.90	
øP	3.75		3.85
Q	2.65		2.95

#### 4.6 IPAK (TO-251) type A package information

Figure 28. IPAK (TO-251) type A package outline

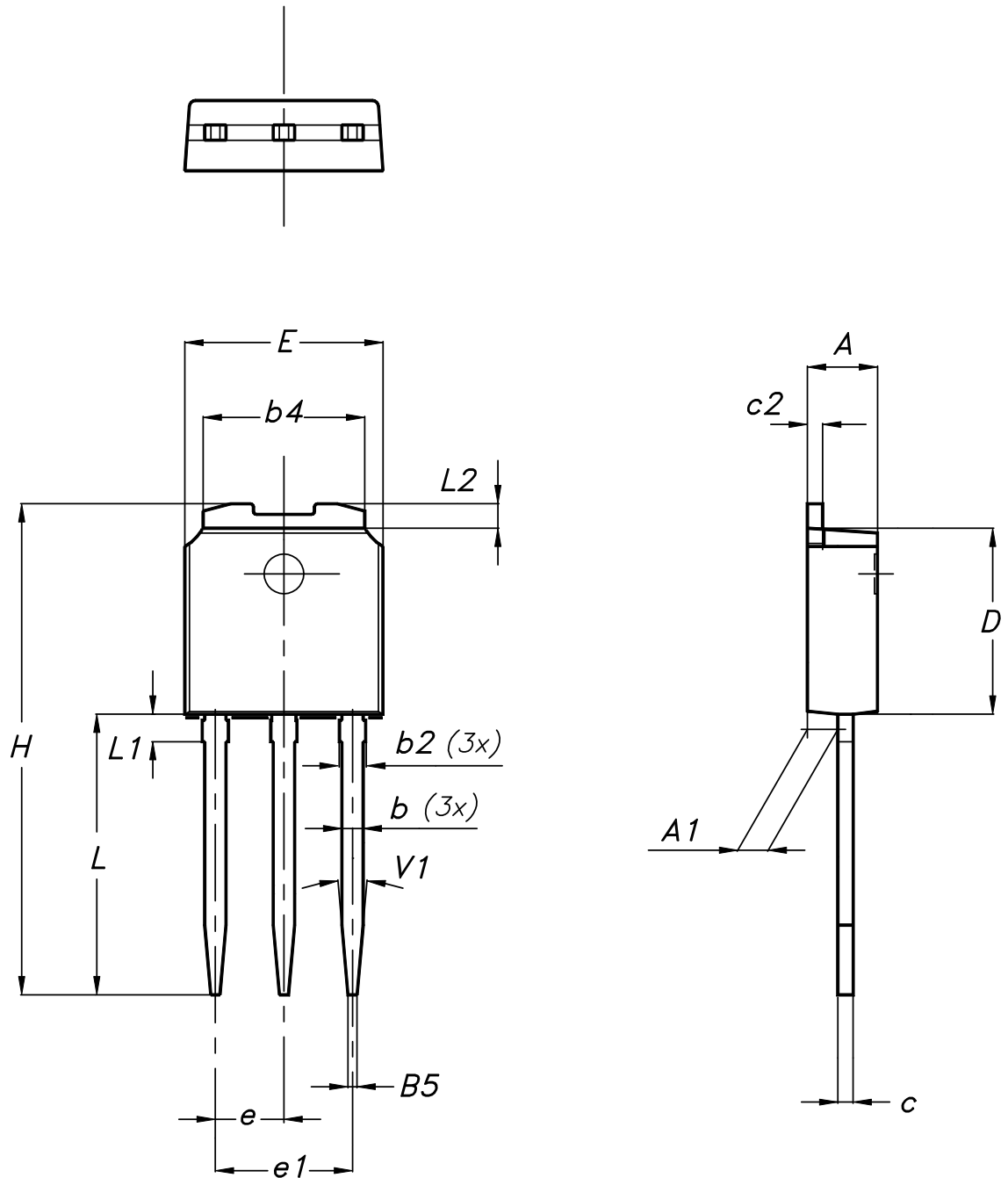

0068771\_IK\_typeA\_rev14

Table 13. IPAK (TO-251) type A package mechanical data

Dim.	mm		
	Min.	Typ.	Max.
A	2.20		2.40
A1	0.90		1.10
b	0.64		0.90
b2			0.95
b4	5.20		5.40
B5		0.30	
c	0.45		0.60
c2	0.48		0.60
D	6.00		6.20
E	6.40		6.60
e		2.28	
e1	4.40		4.60
H		16.10	
L	9.00		9.40
L1	0.80		1.20
L2		0.80	1.00
V1		10°	

#### 4.7 IPAK (TO-251) type C package information

Figure 29. IPAK (TO-251) type C package outline

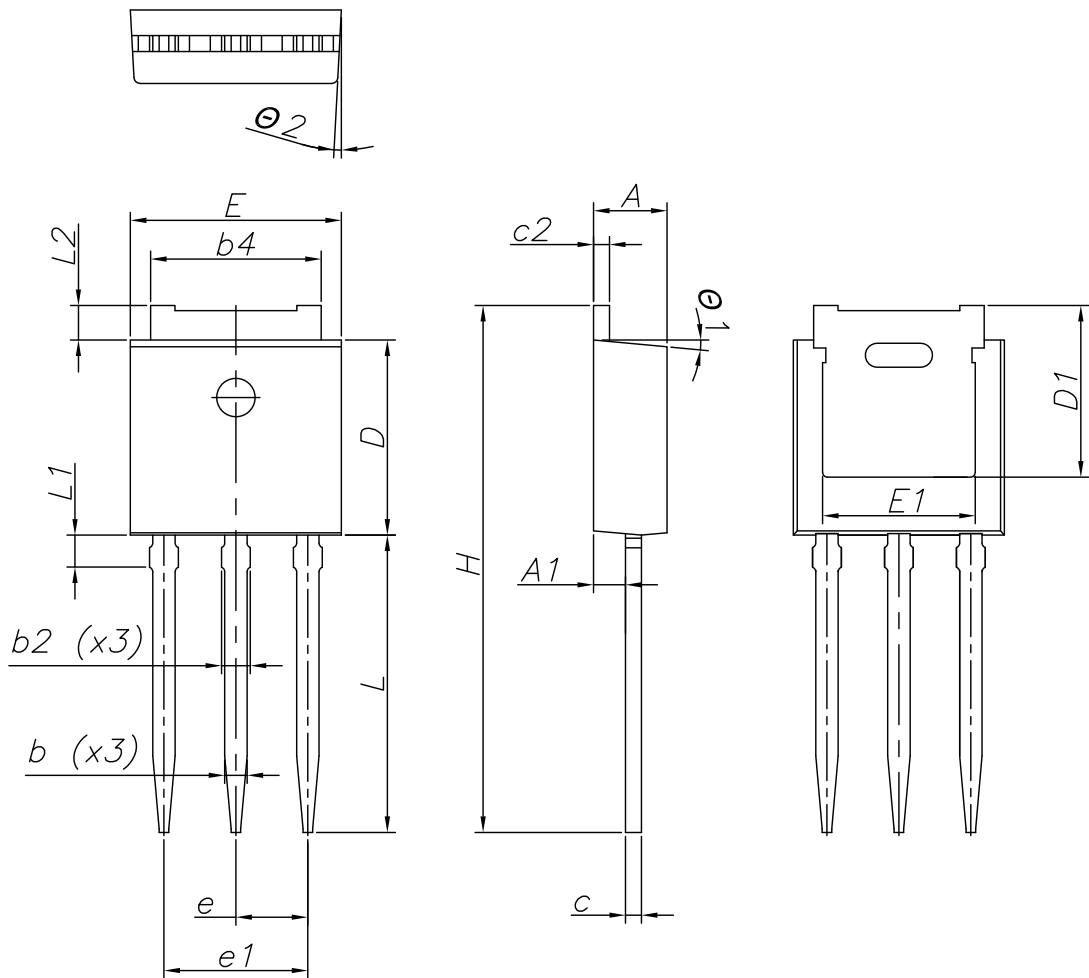

0068771\_IK\_typeC\_rev14

Table 14. IPAK (TO-251) type C package mechanical data

Dim.	mm		
	Min.	Typ.	Max.
A	2.20	2.30	2.35
A1	0.90	1.00	1.10
b	0.66		0.79
b2			0.90
b4	5.23	5.33	5.43
c	0.46		0.59
c2	0.46		0.59
D	6.00	6.10	6.20
D1	5.20	5.37	5.55
E	6.50	6.60	6.70
E1	4.60	4.78	4.95
e	2.20	2.25	2.30
e1	4.40	4.50	4.60
H	16.18	16.48	16.78
L	9.00	9.30	9.60
L1	0.80	1.00	1.20
L2	0.90	1.08	1.25
θ1	3°	5°	7°
θ2	1°	3°	5°

## 5 Ordering information

Table 15. Ordering information

Order code	Marking	Package	Packing
STD11N65M2	11N65M2	DPAK	Tape and reel
STP11N65M2		TO-220	Tube
STU11N65M2		IPAK	



## Revision history

**Table 16. Document revision history**

Date	Revision	Changes
16-May-2014	1	First release.
14-Aug-2015	2	Text and formatting changes throughout document. On cover page: - updated <i>Title, Features and Description</i> In section <i>Electrical characteristics</i> : - updated and renamed table <i>Static</i> (was On /off states) Updated section <i>Electrical characteristics (curves)</i> Updated and renamed section <i>Package information</i> (was Package mechanical data)
17-Aug-2015	3	Datasheet promoted from preliminary data to production data. In section <i>Electrical ratings</i> : - updated and renamed table <i>Absolute maximum ratings</i> In section <i>Electrical characteristics</i> : - updated table <i>Source-drain diode</i> In section <i>Electrical characteristics (curves)</i> - updated figure <i>Thermal impedance for DPAK and IPAK</i> Updated and renamed section <i>IPAK (TO-251) Type C package information</i> (was IPAK (TO-251) Type A package information)
07-Sep-2015	4	Minor text and formatting changes throughout document.
16-Oct-2018	5	Updated <a href="#">Section 4 Package information</a> . Minor text changes.
18-Jun-2019	6	Updated <a href="#">Section 3</a> Minor text changes.

## Contents

<b>1</b>	<b>Electrical ratings</b> .....	<b>2</b>
<b>2</b>	<b>Electrical characteristics</b> .....	<b>3</b>
<b>2.1</b>	Electrical characteristics (curves) .....	5
<b>3</b>	<b>Test circuits</b> .....	<b>8</b>
<b>4</b>	<b>Package information</b> .....	<b>9</b>
<b>4.1</b>	DPAK (TO-252) type A package information .....	9
<b>4.2</b>	DPAK (TO-252) type C package information .....	11
<b>4.3</b>	DPAK (TO-252) type E package information .....	13
<b>4.4</b>	DPAK (TO-252) packing information .....	15
<b>4.5</b>	TO-220 type A package information .....	17
<b>4.6</b>	IPAK (TO-251) type A package information .....	19
<b>4.7</b>	IPAK (TO-251) type C package information .....	21
<b>5</b>	<b>Ordering information</b> .....	<b>24</b>
	<b>Revision history</b> .....	<b>25</b>

**IMPORTANT NOTICE – PLEASE READ CAREFULLY**

STMicroelectronics NV and its subsidiaries (“ST”) reserve the right to make changes, corrections, enhancements, modifications, and improvements to ST products and/or to this document at any time without notice. Purchasers should obtain the latest relevant information on ST products before placing orders. ST products are sold pursuant to ST’s terms and conditions of sale in place at the time of order acknowledgement.

Purchasers are solely responsible for the choice, selection, and use of ST products and ST assumes no liability for application assistance or the design of Purchasers’ products.

No license, express or implied, to any intellectual property right is granted by ST herein.

Resale of ST products with provisions different from the information set forth herein shall void any warranty granted by ST for such product.

ST and the ST logo are trademarks of ST. For additional information about ST trademarks, please refer to [www.st.com/trademarks](http://www.st.com/trademarks). All other product or service names are the property of their respective owners.

Information in this document supersedes and replaces information previously supplied in any prior versions of this document.

© 2019 STMicroelectronics – All rights reserved

单击下面可查看定价，库存，交付和生命周期等信息

[>>STMicro\(意法半导体\)](#)