

## Protection IC for ringing SLICs

Datasheet – production data

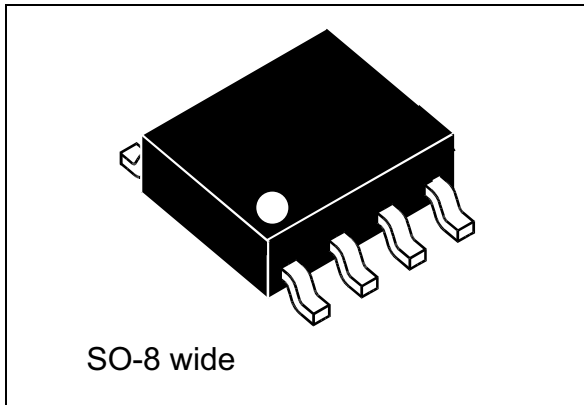

### Features

- Protection IC recommended for ringing SLICs
- Wide firing voltage range: -120 V to +120 V
- Low gate triggering current:  $I_G = 5 \text{ mA max}$
- Peak pulse current:  $I_{PP} = 50 \text{ A (10/1000 } \mu\text{s)}$
- Holding current:  $I_H = 150 \text{ mA min.}$

### Applications

- Dual battery supply voltage SLICs
- Central office (CO)
- Private branch exchange (PBX)
- Digital loop carrier (DLC)
- Digital subscriber line access multiplexer (DSLAM)
- Fiber in the loop (FITL)
- Wireless local loop (WLL)
- Hybrid fiber coax (HFC)
- ISDN terminal adapter
- Cable modem

TM: Trisil is a trademark of STMicroelectronics

### Description

The LCP22 has been developed to protect SLICs operating on both negative and positive battery supplies, as well as high voltage SLICs. It provides crowbar mode protection for both TIP and RING lines. The surge suppression is assumed for each wire by two thyristor structures, one dedicated to positive surges the second one for negative surges. Both positive and negative threshold levels are programmable by two gates.

LCP22 can be used to help equipment to meet various standards such as UL1950, IEC 60950 / CSAC22.2, UL1459 and TIA-968-A. LCP22 pinout and clearance is compatible with UL60950. A Trisil™ meets UL94 V0.

The LCP22 associated with Epcos PTC model B59173C1130A151 is compliant with ITU TK20/K21 (4 kV lightning and AC power fault tests).

Figure 1. Functional diagram

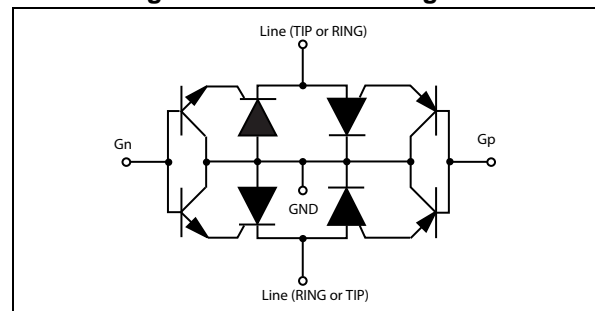
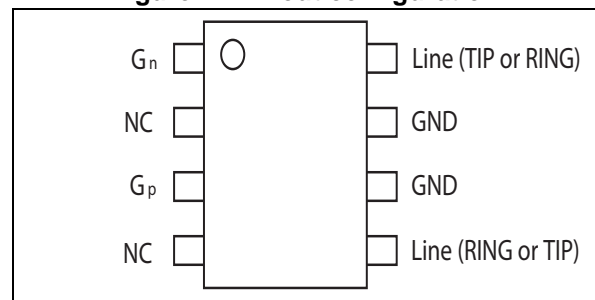

Figure 2. Pin-out configuration



# 1 Characteristics

**Table 1. Compliant with the following standards**

Standard	Peak surge voltage (V)	Voltage waveform	Required peak current (A)	Current waveform	Minimum series resistor Rs to meet standard (Ω)
GR-1089 Core First level	2500	2/10 μs	500	2/10 μs	12
	1000	10/1000 μs	100	10/1000 μs	10
GR-1089 Core Second level	5000	2/10 μs	500	2/10 μs	24
GR-1089 Core Intra-building	1500	2/10 μs	100	2/10 μs	0
ITU-T-K20/K21	6000	10/700 μs	150	5/310 μs	35
	4000		100		10
	1500		37.5		0
ITU-T-K20 (IEC61000-4-2)	8000	1/60 ns	ESD contact discharge		0
	15000		ESD air discharge		0
IEC61000-4-5	4000	10/700 μs	100	5/310 μs	14
	4000	1.2/50 μs	100	8/20 μs	0
TIA-968-A (formerly FCC part 68) type A	1500	10/160 μs	200	10/160 μs	20
	800	10/560 μs	100	10/560 μs	15
TIA-968-A (formerly FCC part 68) type B	1000	9/720 μs	25	5/320 μs	0

**Table 2. Absolute maximum ratings (T<sub>amb</sub> = 25 °C)**

Symbol	Parameter	Value	Unit
I <sub>PP</sub>	Peak pulse current	10/1000 μs	50
		5/310 μs	80
		2/10μs	150
I <sub>TSM</sub>	Non repetitive surge peak on-state current (F = 50 Hz) I <sub>TSM</sub> value specified for each line I <sub>TSM</sub> value can be applied on both lines at the same time (GND capability is twice the line I <sub>TSM</sub> )	t <sub>p</sub> = 0.2 s	11
		t <sub>p</sub> = 1 s	7.5
		t <sub>p</sub> = 15 min.	3
V <sub>Gn</sub> V <sub>Gp</sub>	Negative battery voltage range Positive battery voltage range	-120 to 0 0 to +120	V
T <sub>j</sub>	Operating junction temperature range	-55 to +125	°C
T <sub>stg</sub>	Storage temperature range	-55 to +150	°C
T <sub>L</sub>	Lead solder temperature (10 s duration)	260	°C



Figure 3. Pulse waveform

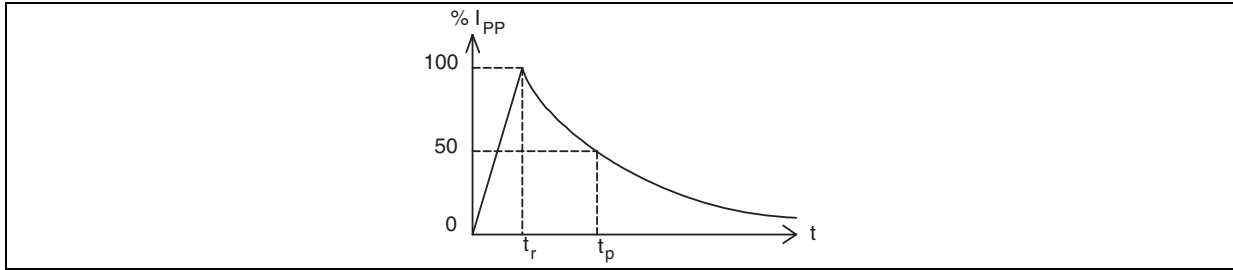

Table 3. Thermal resistance

Symbol	Parameter	Value	Unit
$R_{th(j-a)}$	Junction to ambient	150	°C/W

Table 4. Parameters related to the negative suppressor

Symbol	Parameter	Test conditions	Min.	Max.	Unit
$I_{Gn}$	Negative gate trigger current	$V_{Gn/GND} = -60\text{ V}$ Measured at 50 Hz		5	mA
$I_H$	Holding current (see Figure 4)	$V_{Gn} = -60\text{ V}$	150		mA
$V_{DGL-}$	Dynamic switching voltage $G_n$ / TIP or RING <sup>(1)</sup>	$V_{Gn/GND} = -60\text{ V}$ 10/700 $\mu\text{s}$ 2 kV $R_s = 25\ \Omega$ $I_{PP} = 30\text{ A}$ 1.2/50 $\mu\text{s}$ 2 kV $R_s = 25\ \Omega$ $I_{PP} = 30\text{ A}$		8 12	V
$V_{GnT}$	$G_n$ to TIP voltage	$I_{Gn} = 20\text{ mA}$	0.7	1.7	V

1. The  $V_{DGL}$  value is the difference between the peak line voltage during the surge and the programmed gate voltage.

Table 5. Parameters related to the positive suppressor

Symbol	Parameter	Test conditions	Min.	Max.	Unit
$I_{Gp}$	Positive gate trigger current	$V_{Gp/GND} = 60\text{ V}$ , measured at 50 Hz		5	mA
$V_{DGL+}$	Dynamic switching voltage $G_p$ / TIP or RING <sup>(1)</sup>	$V_{Gp/GND} = 60\text{ V}$ 10/700 $\mu\text{s}$ 2 kV $R_s = 25\ \Omega$ $I_{PP} = 30\text{ A}$ 1.2/50 $\mu\text{s}$ 2 kV $R_s = 25\ \Omega$ $I_{PP} = 30\text{ A}$		8 20	V
$V_{GpR}$	$G_p$ to RING voltage	$I_{Gp} = -20\text{ mA}$	1	2	V

1. The  $V_{DGL}$  value is the difference between the peak line voltage during the surge and the programmed gate voltage.

Table 6. Parameters related to TIP or RING / GND

Symbol	Parameter	Test conditions	Min.	Max.	Unit
$I_R$	Reverse leakage current	$V_{TIP\text{ or RING}} = +120\text{ V}$ $V_{Gp/TIP\text{ or RING}} = +1\text{ V}$ $V_{TIP\text{ or RING}} = -120\text{ V}$ $V_{Gn/TIP\text{ or RING}} = -1\text{ V}$		5 5	$\mu\text{A}$
C	Capacitance TIP or RING / GND	$V_R = -3\text{ V}$ , $F = 1\text{ MHz}$ , $V_{Gp} = 60\text{ V}$ , $V_{Gn} = -60\text{ V}$		60	pF

Table 7. Recommended gate capacitance

Symbol	Component	Min.	Typ.	Max.	Unit
$C_n, C_p$	Gate decoupling capacitance	100	220		nF

Figure 4. Relative variation of holding current versus junction temperature

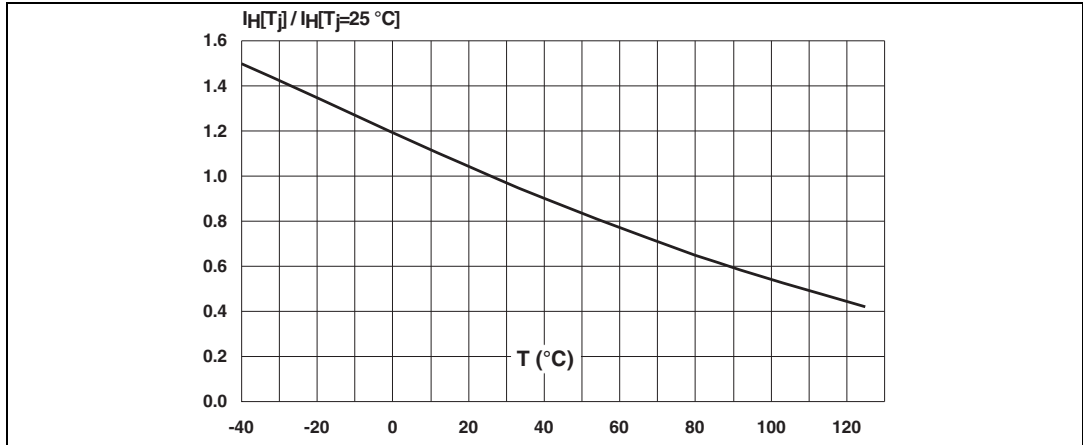

Figure 5. Maximum non repetitive surge peak on state current versus overload duration

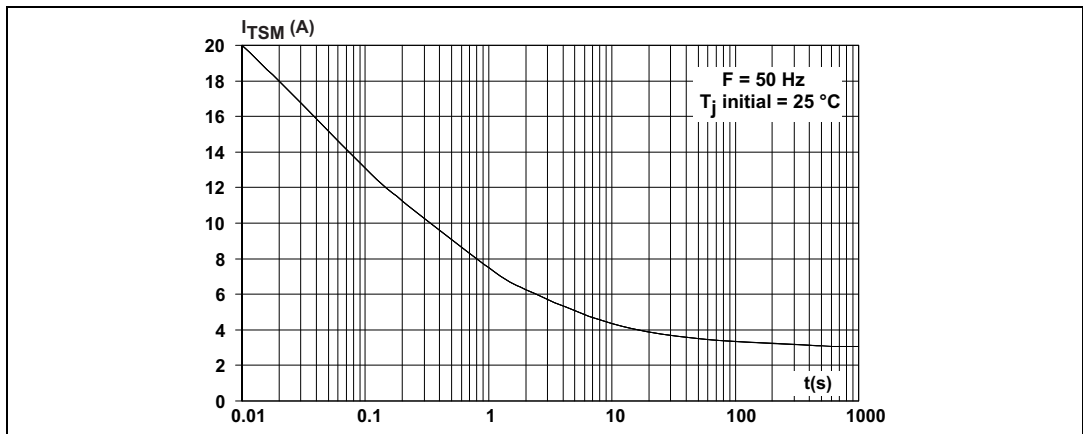
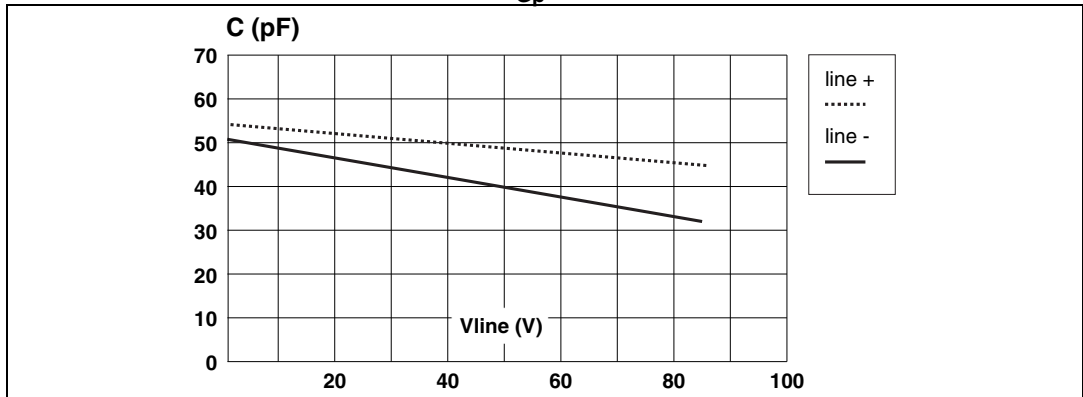

Figure 6. Capacitance versus reverse applied voltage (typical values) with  $V_{Gn} = -90\text{ V}$  and  $V_{Gp} = +90\text{ V}$



## 2 Technical information

Figure 7. LCP22 concept behavior

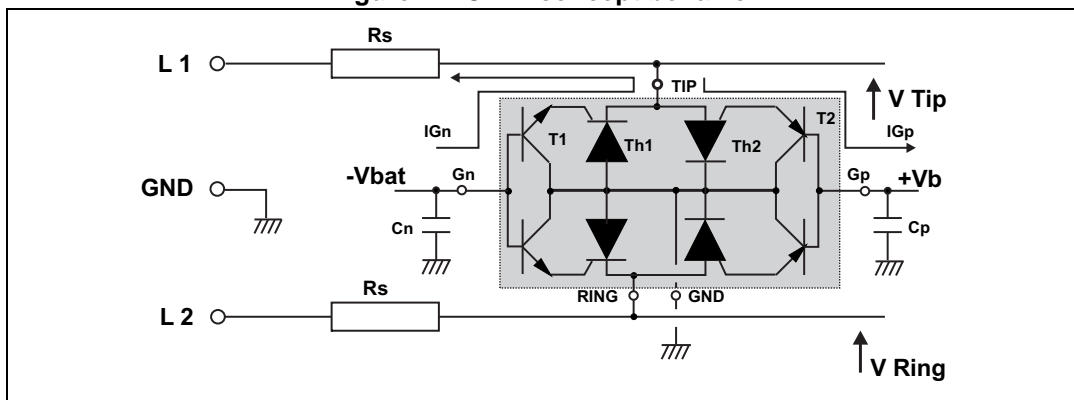

Figure 7 shows the classical protection circuit using the LCP22 crowbar concept. This topology has been developed to protect two-battery voltage SLICs. It allows both positive and negative firing thresholds to be programmed. The LCP22 has two gates (Gn and Gp). Gn is biased to negative battery voltage -Vbat, while Gp is biased to the positive battery voltage +Vb.

When a negative surge occurs on one wire (L1 for example), a current IGn flows through the base of the transistor T1 and then injects a current in the gate of the thyristor Th1 which turns-on. All the surge current flows through the ground. After the surge, when the current flowing through Th1 becomes less negative than the negative holding current IH-, Th1 switches off. This holding current IH- is temperature dependent as per Figure 4

When a positive surge occurs on one wire (L1 for example), a current IGp flows through the base of the transistor T2 and then injects a current in the gate of the thyristor Th2 which fires. All the surge current flows through the ground. After the surge, when the current flowing through Th2 becomes less positive than the positive holding current IH+, Th2 switches off. This holding current IH+, typically 20 mA at 25 °C, is temperature dependent and the same Figure 4 also applies.

The capacitors Cn and Cp are used to speed up the crowbar structure firing during the fast rise or fall edges. This allows minimization of the dynamic breakover voltage at the SLIC TIP and RING inputs during fast surges. Please note that these capacitors are generally available around the SLIC. To be efficient they have to be as close as possible to the LCP22 gate pins (Gn and Gp) and to the reference ground track (or plan). The optimized value for Cn and Cp is 220 nF.

The series resistors Rs shown in Figure 7 represent the fuse resistors or the PTCs which are needed to withstand the power contact or the power induction tests imposed by the country standards. Taking this factor into account, the actual lightning surge current flowing through the LCP22 is equal to:

$$I_{surge} = V_{surge} / (R_g + R_s)$$

With

V surge = peak surge voltage imposed by the standard.

Rg = series resistor of the surge generator

Rs = series resistor of the line card (e.g. PTC)

For a line card with 50 Ω of series resistors which has to be qualified under GR-1089 1000 V 10/1000 μs surge, the present current through the LCP22 is equal to:

$$I_{\text{surge}} = 1000 / (10 + 50) = 17 \text{ A}$$

The LCP22 topology is particularly optimized for the new telecom applications such as fiber in the loop, WLL systems, and decentralized central office, for example.

**Figure 8. Protection of SLIC with positive and negative battery voltages**

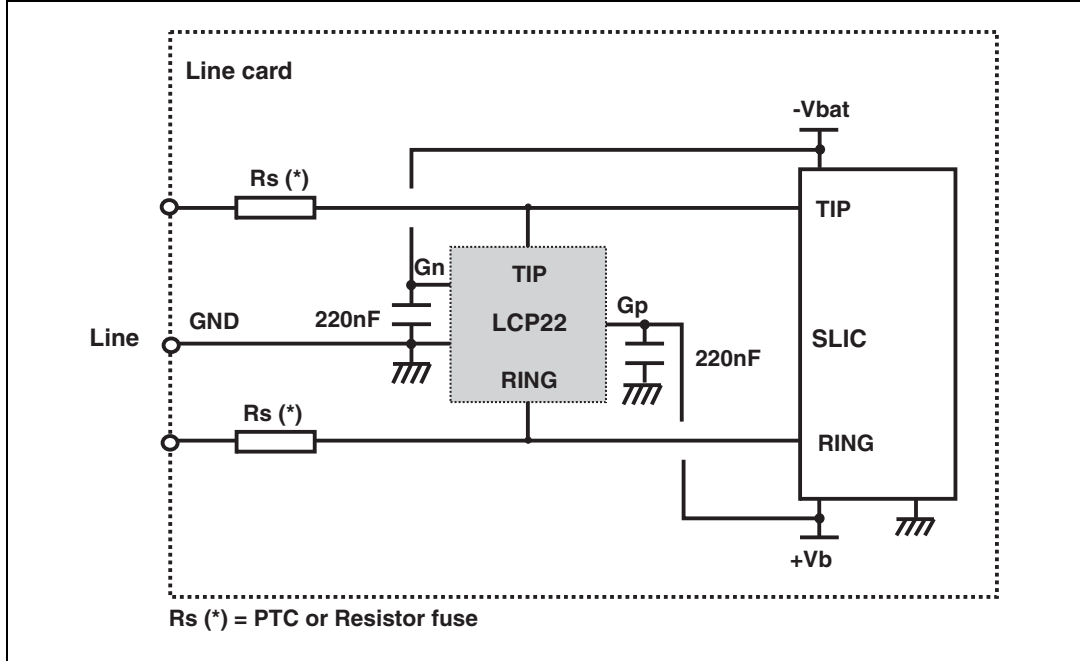

Figure 8 shows the classical protection topology for SLIC using both positive and negative battery voltages. With such a topology the SLIC is protected against surge over +Vb and lower than -Vbat. In this case, +Vb can be programmed up to +120 V while -Vbat can be programmed down to -120 V.

### 3 Package information

- Epoxy meets UL94, V0
- Lead-free package

In order to meet environmental requirements, ST offers these devices in different grades of ECOPACK<sup>®</sup> packages, depending on their level of environmental compliance. ECOPACK<sup>®</sup> specifications, grade definitions and product status are available at: [www.st.com](http://www.st.com). ECOPACK<sup>®</sup> is an ST trademark.

Figure 9. SO-8 wide dimension definitions

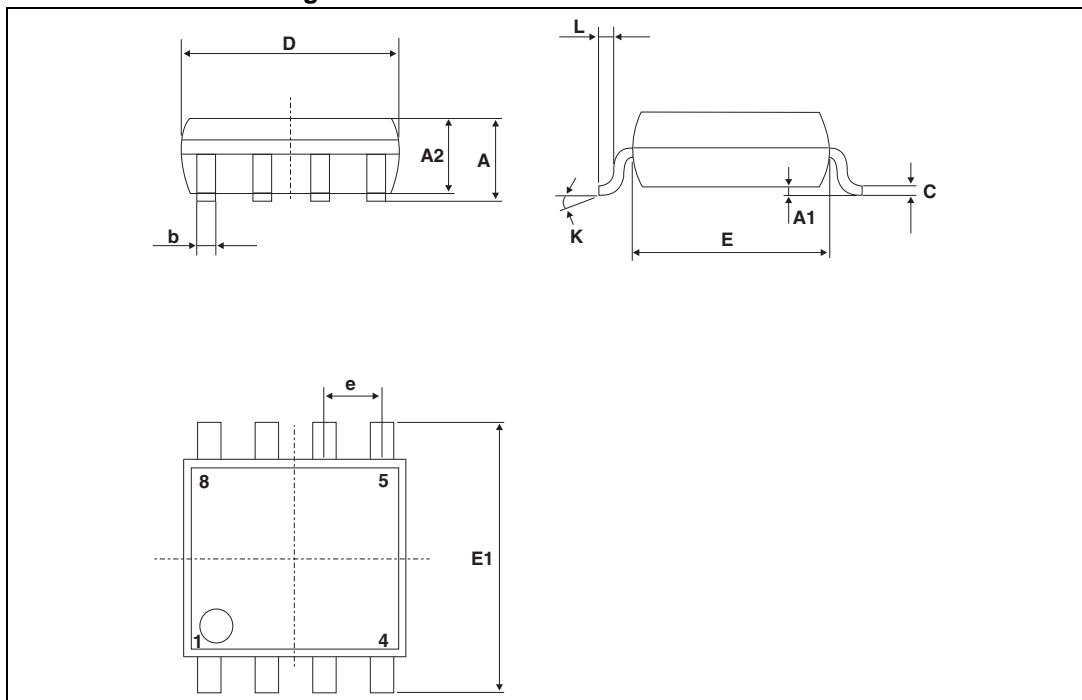

Table 8. SO-8 wide dimension values

Ref.	Dimensions					
	Millimeters			Inches		
	Min.		Max.	Min.		Max.
A	1.70	1.90	2.10	0.07	0.07	0.08
A1	0.05	0.10	0.25	0.00	0.00	0.01
A2	1.65	1.80	1.75	0.06	0.07	0.07
b	0.38	0.43	0.48	0.01	0.02	0.02
c	0.15	0.20	0.25	0.01	0.01	0.01
D	5.14	5.24	5.34	0.02	0.021	0.21
E	5.20	5.30	5.40	0.02	0.021	0.21
E1	7.70	7.80	8.25	0.30	0.031	0.32
e		1.27		0.05	0.05	
K			8.00	0.14	0.31	
L	0.55	0.75	0.85	0.02	0.03	0.03

Figure 10. SO-8 wide footprint in mm (inches)

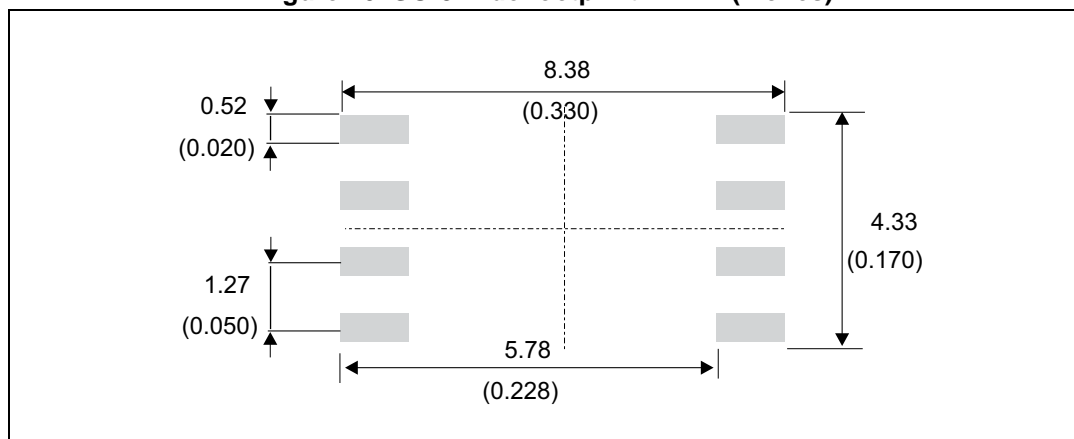
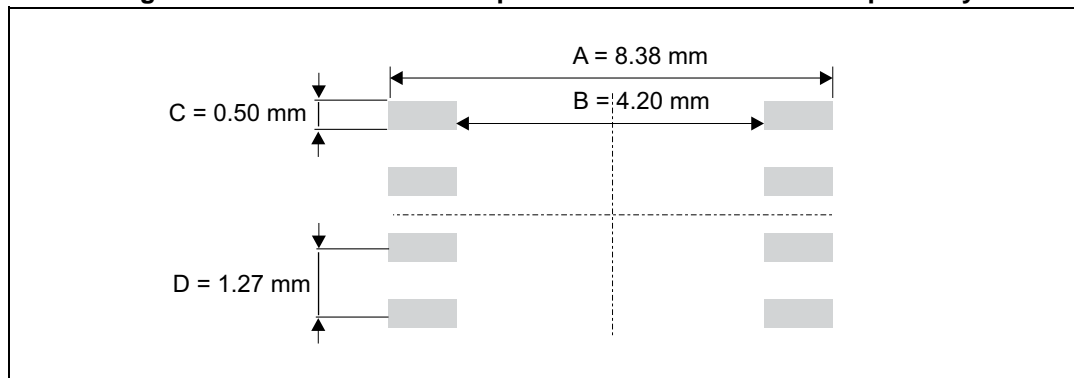

Figure 11. Recommended footprint for SO-8/SO-8 wide compatibility





## 4 Ordering information

**Table 9. Ordering information**

Order code	Marking	Package	Weight	Base qty	Delivery mode
LCP22-150B1RL	LCP22	SO-8 wide	0.125g	1500	Tape and reel

## 5 Revision history

**Table 10. Document revision history**

Date	Revision	Changes
07-Feb-2014	1	Initial release.
03-Jun-2014	2	Updated <a href="#">Figure 1: Functional diagram</a> , <a href="#">Figure 2: Pin-out configuration</a> and $T_j$ value in <a href="#">Table 2: Absolute maximum ratings</a> ( $T_{amb} = 25\text{ °C}$ ).
22-Oct-2014	3	Added <a href="#">Figure 11</a> .

**IMPORTANT NOTICE – PLEASE READ CAREFULLY**

STMicroelectronics NV and its subsidiaries ("ST") reserve the right to make changes, corrections, enhancements, modifications, and improvements to ST products and/or to this document at any time without notice. Purchasers should obtain the latest relevant information on ST products before placing orders. ST products are sold pursuant to ST's terms and conditions of sale in place at the time of order acknowledgement.

Purchasers are solely responsible for the choice, selection, and use of ST products and ST assumes no liability for application assistance or the design of Purchasers' products.

No license, express or implied, to any intellectual property right is granted by ST herein.

Resale of ST products with provisions different from the information set forth herein shall void any warranty granted by ST for such product.

ST and the ST logo are trademarks of ST. All other product or service names are the property of their respective owners.

Information in this document supersedes and replaces information previously supplied in any prior versions of this document.

© 2014 STMicroelectronics – All rights reserved

单击下面可查看定价，库存，交付和生命周期等信息

[>>STMicro\(意法半导体\)](#)