

## General purpose input/output rail-to-rail low-power operational amplifiers

### Pin connections (top view)

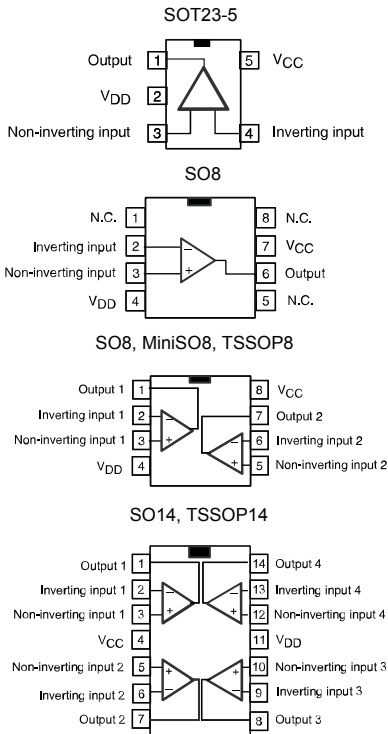

### Features

- Operating range  $V_{CC} = 2.5\text{ V to }6\text{ V}$
- Rail-to-rail input and output
- Extended  $V_{icm}$  ( $V_{DD} - 0.2\text{ V to }V_{CC} + 0.2\text{ V}$ )
- Capable of driving a  $32\ \Omega$  load resistor
- High stability: 500 pF
- Operating temperature range:  $-40\text{ to }125\text{ }^\circ\text{C}$

### Applications

- Battery powered applications
- Audio driver (headphone driver)
- Sensor signal conditioning
- Laptop/notebook computers

### Description

The TSV358, TSV358A, TSV324, and TSV324A (dual and quad) devices are low voltage versions of the LM358 and LM324 commodity operational amplifiers. The TSV321 and TSV321A are the single version. All devices operate with voltages as low as 2.5 V and feature both I/O rail-to-rail.

The common mode input voltage extends 200 mV beyond the supply voltages at 25 °C while the output voltage swing is within 100 mV of each rail with a 600  $\Omega$  load resistor. At  $V_{CC} = 3\text{ V}$ , these devices offer 1.3 MHz of gain bandwidth product and provide high output current capability with a typical value of 80 mA.

These features make the TSV3xx and TSV3xxA family ideal for active filters, general purpose low voltage applications, and general purpose portable devices.

#### Maturity status link

[TSV321, TSV358, TSV324,](#)  
[TSV321A, TSV358A, TSV324A](#)

#### Related products

LMV321L, LMV358L, LMV324L	for newer technology version
TSV851, TSV852, TSV854	for enhanced performances

# 1 Absolute maximum ratings and operating conditions

**Table 1. Absolute maximum ratings**

Symbol	Parameter	Value	Unit	
$V_{CC}$	Supply voltage <sup>(1)</sup>	7	V	
$V_{id}$	Differential input voltage <sup>(2)</sup>	$\pm 1$		
$V_{in}$	Input voltage	$V_{DD} - 0.3$ to $V_{CC} + 0.3$		
$T_{stg}$	Storage temperature	-65 to +150	°C	
$T_j$	Maximum junction temperature	150		
$R_{thja}$	Thermal resistance junction-to-ambient <sup>(3)</sup>	SOT23-5	250	°C/W
		SO8	125	
		MiniSO8	190	
		TSSOP8	120	
		SO14	105	
		TSSOP14	100	
$R_{thjc}$	Thermal resistance junction-to-case <sup>(3)</sup>	SOT23-5	81	
		SO8	40	
		MiniSO8	39	
		TSSOP8	37	
		SO14	31	
		TSSOP14	32	
ESD	HBM: human body model <sup>(4)</sup>	2	kV	
	MM: machine model <sup>(5)</sup>	200	V	
	CDM: charged device model <sup>(6)</sup>	1.5	kV	
	Latch-up immunity	200	mA	
	Lead temperature (soldering, 10 s)	250	°C	
	Output short-circuit duration	See <sup>(7)</sup>		

- All voltage values, except the differential voltage are with respect to the network terminal.
- The differential voltage is the non-inverting input terminal with respect to the inverting input terminal. If  $V_{id} > \pm 1$  V, the maximum input current must not exceed  $\pm 1$  mA. When  $V_{id} > \pm 1$  V, an input series resistor must be added to limit input current.
- Short-circuits can cause excessive heating and destructive dissipation.  $R_{th}$  are typical values.
- Human body model: 100 pF discharged through a 1.5 k $\Omega$  resistor between two pins of the device, done for all couples of pin combinations with other pins floating.
- Machine model: a 200 pF capacitor is charged to the specified voltage, then discharged directly between two pins of the device with no external series resistor (internal resistor < 5  $\Omega$ ), done for all couples of pin combinations with other pins floating.
- Charged device model: all pins plus package are charged together to the specified voltage and then discharged directly to ground.
- Short-circuits from the output to  $V_{CC}$  can cause excessive heating. The maximum output current is approximately 80 mA, independent of the magnitude of  $V_{CC}$ . Destructive dissipation can result from simultaneous short-circuits on all amplifiers.



Table 2. Operating conditions

Symbol	Parameter	Value	Unit
$V_{CC}$	Supply voltage	2.5 to 6	V
$V_{icm}$	Common mode input voltage range	$T_{amb} = 25\text{ }^{\circ}\text{C}, 2.5 \leq V_{CC} \leq 6\text{ V}$	$V_{DD} - 0.2\text{ to }V_{CC} + 0.2$
		$T_{min} < T_{amb} < T_{max}, 2.5 \leq V_{CC} \leq 5.5\text{ V}$	$V_{DD}\text{ to }V_{CC}$
$T_{oper}$	Operating free air temperature range	-40 to + 125	$^{\circ}\text{C}$

## 2 Electrical characteristics

**Table 3. Electrical characteristics at  $V_{CC} = +3\text{ V}$ ,  $V_{DD} = 0\text{ V}$ ,  $R_L$ ,  $C_L$  connected to  $V_{CC}/2$ , and  $T_{amb} = 25\text{ °C}$  (unless otherwise specified)**

Symbol	Parameter	Test conditions	Min.	Typ.	Max.	Unit
$V_{io}$	Input offset voltage	$V_{icm} = V_{out} = V_{CC}/2$				mV
		TSV321/358/324		0.2	3	
		$T_{min} \leq T_{amb} \leq T_{max}$			6	
		TSV321A/358A/324A		0.1	1	
		$T_{min} \leq T_{amb} \leq T_{max}$			3	
$\Delta V_{io}/\Delta T$	Input offset voltage drift			2		$\mu\text{V}/\text{°C}$
$I_{io}$	Input offset current	$V_{icm} = V_{out} = V_{CC}/2$ <sup>(1)</sup>		3	30	nA
		$T_{min} \leq T_{amb} \leq T_{max}$			60	
$I_{ib}$	Input bias current	$V_{icm} = V_{out} = V_{CC}/2$ <sup>(1)</sup>		40	125	
		$T_{min} \leq T_{amb} \leq T_{max}$			150	
CMR	Common mode rejection ratio 20 log ( $\Delta V_{ic}/\Delta V_{io}$ )	$0 \leq V_{icm} \leq V_{CC}$ , $V_{out} = V_{CC}/2$	60	80		dB
$A_{vd}$	Large signal voltage gain	$V_{out} = 0.5\text{ V to }2.5\text{ V}$ , $R_L = 2\text{ k}\Omega$	80	92		
		$V_{out} = 0.5\text{ V to }2.5\text{ V}$ , $R_L = 600\ \Omega$	74	95		
$V_{OH}$	High level output voltage, $V_{OH} = V_{out}$	$V_{id} = 100\text{ mV}$ , $R_L = 2\text{ k}\Omega$	2.82	2.95		V
		$V_{id} = 100\text{ mV}$ , $R_L = 600\ \Omega$	2.80	2.95		
		$V_{id} = 100\text{ mV}$ , $T_{min} \leq T_{amb} \leq T_{max}$ , $R_L = 2\text{ k}\Omega$	2.82			
		$V_{id} = 100\text{ mV}$ , $T_{min} \leq T_{amb} \leq T_{max}$ , $R_L = 600\ \Omega$	2.80			
$V_{OL}$	Low level output voltage	$V_{id} = -100\text{ mV}$ , $R_L = 2\text{ k}\Omega$		88	120	mV
		$V_{id} = -100\text{ mV}$ , $R_L = 600\ \Omega$		115	160	
		$V_{id} = -100\text{ mV}$ , $T_{min} \leq T_{amb} \leq T_{max}$ , $R_L = 2\text{ k}\Omega$			120	
		$V_{id} = -100\text{ mV}$ , $T_{min} \leq T_{amb} \leq T_{max}$ , $R_L = 600\ \Omega$			160	
$I_o$	Output source current	$V_{id} = 100\text{ mV}$ , $V_O = V_{DD}$	20	80		mA
	Output sink current	$V_{id} = -100\text{ mV}$ , $V_O = V_{CC}$	20	80		
$I_{CC}$	Supply current (per amplifier)	$A_{VCL} = 1$ , no load		420	650	$\mu\text{A}$
		$T_{min} \leq T_{amb} \leq T_{max}$			690	
GBP	Gain bandwidth product	$R_L = 10\text{ k}\Omega$ , $C_L = 100\text{ pF}$ , $f = 100\text{ kHz}$	1	1.3		MHz
SR	Slew rate	$R_L = 10\text{ k}\Omega$ , $C_L = 100\text{ pF}$	0.42	0.6		$\text{V}/\mu\text{s}$
$\phi_m$	Phase margin	$C_L = 100\text{ pF}$		53		Degrees
en	Input voltage noise			27		$\text{nV}/\sqrt{\text{Hz}}$
THD	Total harmonic distortion			0.01		%

1. Maximum values include unavoidable inaccuracies of the industrial tests.

**Table 4. Electrical characteristics at  $V_{CC} = +5\text{ V}$ ,  $V_{DD} = 0\text{ V}$ ,  $R_L$ ,  $C_L$  connected to  $V_{CC}/2$ , and  $T_{amb} = 25\text{ °C}$  (unless otherwise specified)**

Symbol	Parameter	Conditions	Min.	Typ.	Max.	Unit
$V_{io}$	Input offset voltage	$V_{icm} = V_{out} = V_{CC}/2$				mV
		TSV321/358/324		0.2	3	
		$T_{min} \leq T_{amb} \leq T_{max}$			6	
		TSV321A/358A/324A		0.1	1	
		$T_{min} \leq T_{amb} \leq T_{max}$			3	
$\Delta V_{io}/\Delta T$	Input offset voltage drift			2		$\mu\text{V}/\text{°C}$
$I_{io}$	Input offset current	$V_{icm} = V_{out} = V_{CC}/2$ <sup>(1)</sup>		3	30	nA
		$T_{min} \leq T_{amb} \leq T_{max}$			60	
$I_{ib}$	Input bias current	$V_{icm} = V_{out} = V_{CC}/2$ <sup>(1)</sup>		70	130	
		$T_{min} \leq T_{amb} \leq T_{max}$			150	
CMR	Common mode rejection ratio 20 log ( $\Delta V_{ic}/\Delta V_{io}$ )	$0 \leq V_{icm} \leq V_{CC}$ , $V_{out} = V_{CC}/2$	65	85		dB
SVR	Supply voltage rejection ratio 20 log ( $\Delta V_{CC}/\Delta V_{io}$ )	$V_{CC} = 2.5\text{ V to }5\text{ V}$	70	90		
$A_{vd}$	Large signal voltage gain	$V_{out} = 0.5\text{ V to }4.5\text{ V}$ , $R_L = 2\text{ k}\Omega$	83	92		
		$V_{out} = 0.5\text{ V to }4.5\text{ V}$ , $R_L = 600\ \Omega$	77	85		
$V_{OH}$	High level output voltage, $V_{OH} = V_{out}$	$V_{id} = 100\text{ mV}$ , $R_L = 2\text{ k}\Omega$	4.80	4.95		V
		$V_{id} = 100\text{ mV}$ , $R_L = 600\ \Omega$	4.75	4.90		
		$V_{id} = 100\text{ mV}$ , $T_{min} \leq T_{amb} \leq T_{max}$ , $R_L = 2\text{ k}\Omega$	4.80			
		$V_{id} = 100\text{ mV}$ , $T_{min} \leq T_{amb} \leq T_{max}$ , $R_L = 600\ \Omega$	4.75			
$V_{OL}$	Low level output voltage	$V_{id} = -100\text{ mV}$ , $R_L = 2\text{ k}\Omega$		88	130	mV
		$V_{id} = -100\text{ mV}$ , $R_L = 600\ \Omega$		115	188	
		$V_{id} = -100\text{ mV}$ , $T_{min} \leq T_{amb} \leq T_{max}$ , $R_L = 2\text{ k}\Omega$			130	
		$V_{id} = -100\text{ mV}$ , $T_{min} \leq T_{amb} \leq T_{max}$ , $R_L = 600\ \Omega$			188	
$I_o$	Output source current	$V_{id} = 100\text{ mV}$ , $V_O = V_{DD}$	20	80		mA
	Output sink current	$V_{id} = -100\text{ mV}$ , $V_O = V_{CC}$	20	80		
$I_{CC}$	Supply current (per amplifier)	$A_{VCL} = 1$ , no load		500	835	$\mu\text{A}$
		$T_{min} \leq T_{amb} \leq T_{max}$			875	
GBP	Gain bandwidth product	$R_L = 10\text{ k}\Omega$ , $C_L = 100\text{ pF}$ , $f = 100\text{ kHz}$	1	1.4		MHz
SR	Slew rate	$R_L = 10\text{ k}\Omega$ , $C_L = 100\text{ pF}$	0.42	0.6		V/ $\mu\text{s}$
$\phi_m$	Phase margin	$C_L = 100\text{ pF}$		55		Degrees
en	Input voltage noise			27		nV/ $\sqrt{\text{Hz}}$
THD	Total harmonic distortion			0.01		%

1. Maximum values include unavoidable inaccuracies of the industrial tests.

Figure 1. Supply current/amplifier vs. supply voltage

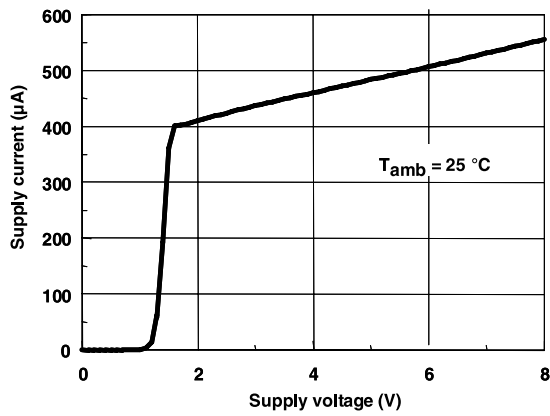

Figure 2. Supply current/amplifier vs. temperature

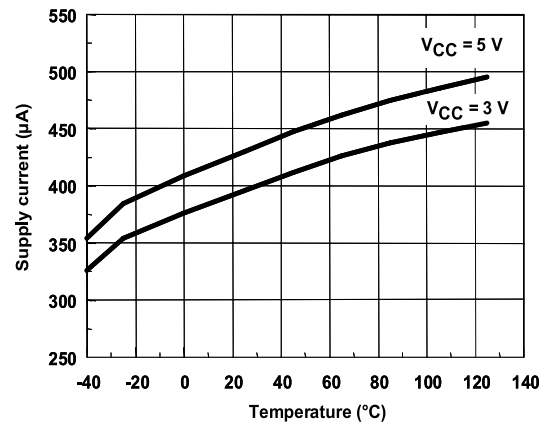

Figure 3. Output power vs. supply voltage

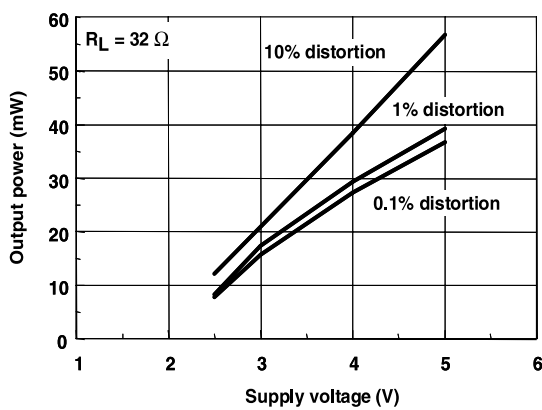

Figure 4. Input offset voltage drift vs. temperature

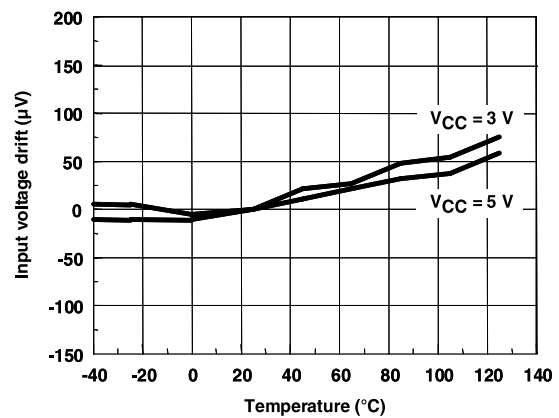

Figure 5. Input bias current vs. temperature

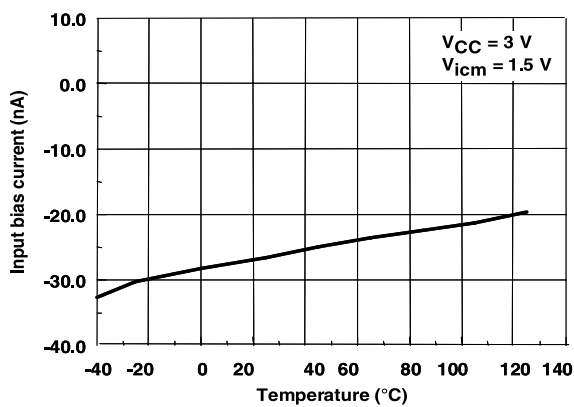

Figure 6. Open loop gain vs. temperature at VCC = 5 V

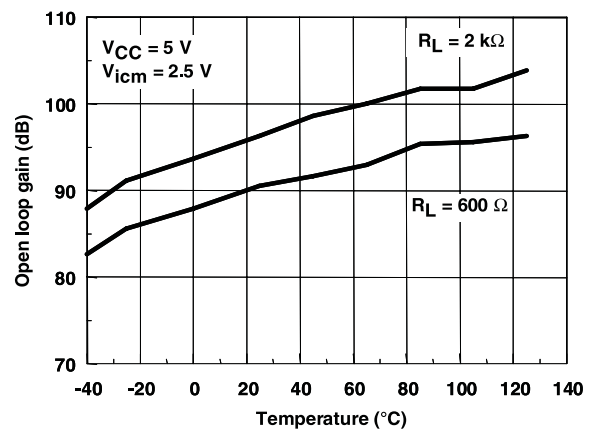

Figure 7. Open loop gain vs. temperature at  $V_{CC} = 3\text{ V}$

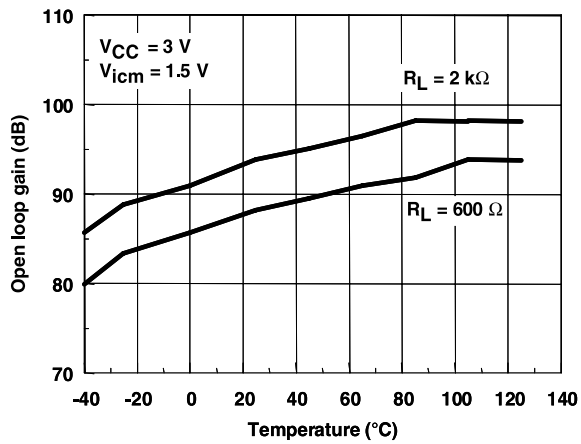

Figure 8. High level output voltage vs. temperature

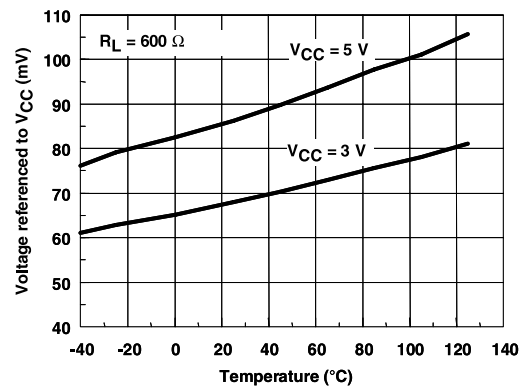

Figure 9. Low level output voltage vs. temperature

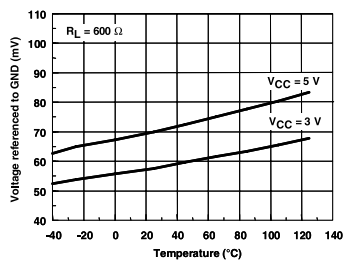

Figure 10. Output current vs. temperature at  $V_{CC} = 5\text{ V}$

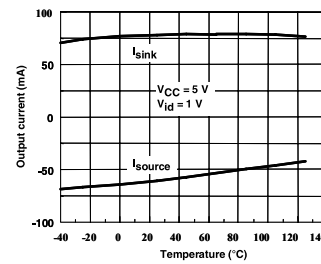

Figure 11. Output current vs. temperature at  $V_{CC} = 3\text{ V}$

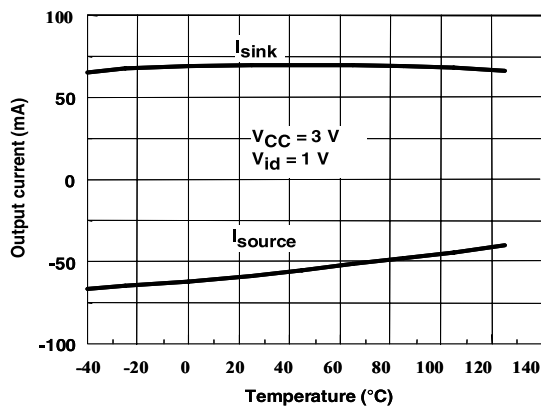

Figure 12. Output current vs. output voltage at  $V_{CC} = 5\text{ V}$

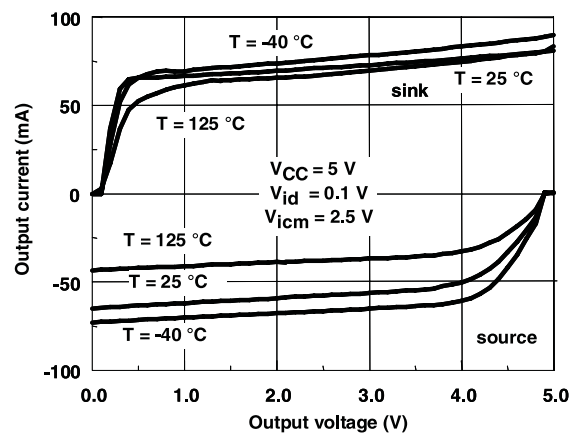

Figure 13. Output current vs. output voltage at  $V_{CC} = 3\text{ V}$

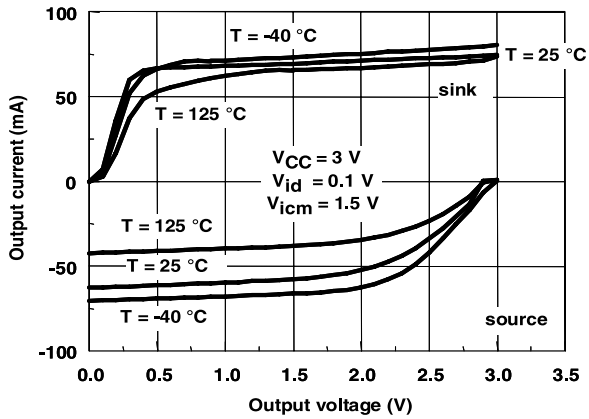

Figure 14. Gain and phase vs. frequency at  $V_{CC} = 5\text{ V}$

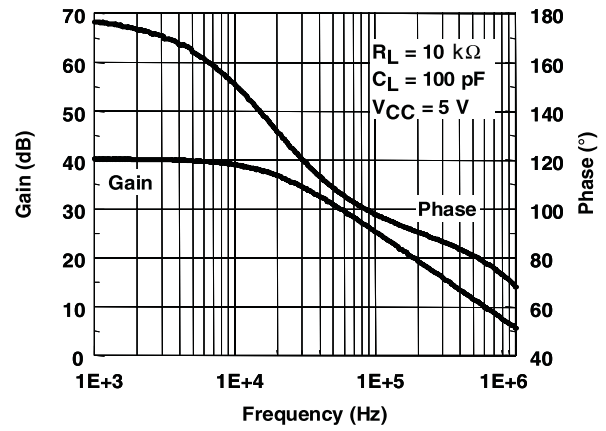

Figure 15. Gain and phase vs. frequency at  $V_{CC} = 3\text{ V}$

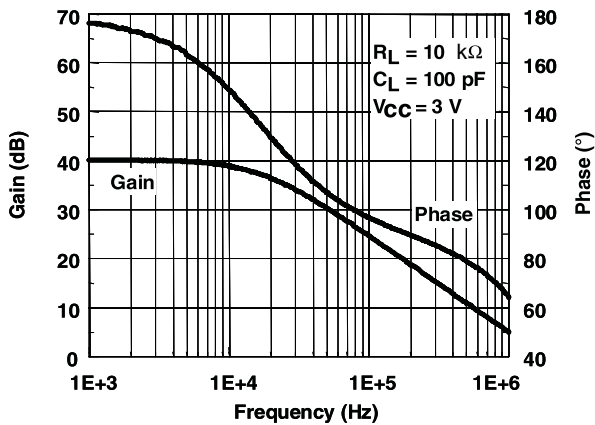

Figure 16. Slew rate vs. temperature at  $V_{CC} = 5\text{ V}$

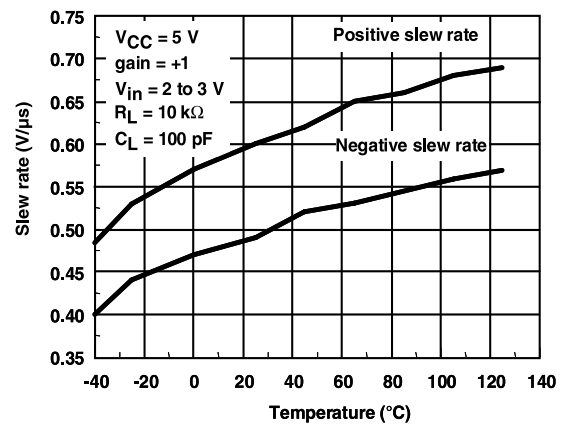

Figure 17. Slew rate vs. temperature at  $V_{CC} = 3\text{ V}$

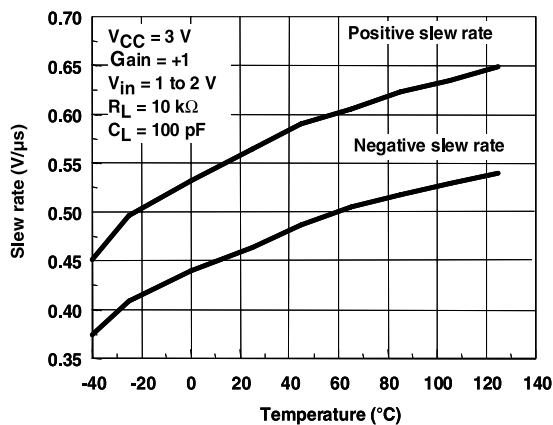
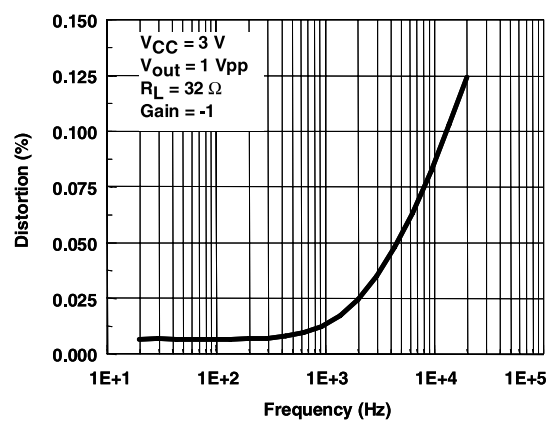

Figure 18. Distortion vs. frequency







### 3 Package information

---

In order to meet environmental requirements, ST offers these devices in different grades of ECOPACK® packages, depending on their level of environmental compliance. ECOPACK specifications, grade definitions and product status are available at: [www.st.com](http://www.st.com). ECOPACK is an ST trademark.

### 3.1 SOT23-5 package information

Figure 19. SOT23-5 package outline

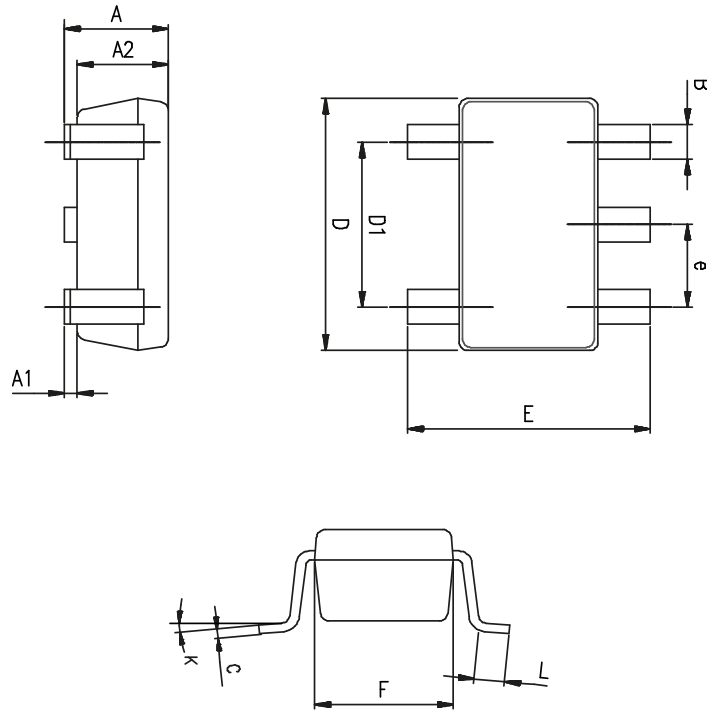

Table 5. SOT23-5 package mechanical data

Symbol	Dimensions					
	Millimeters			Mils		
	Min.	Typ.	Max.	Min.	Typ.	Max.
A	0.90		1.45	35.4		57.1
A1	0.00		0.15	0.00		5.9
A2	0.90		1.30	35.4		51.2
b	0.35		0.50	13.7		19.7
C	0.09		0.20	3.5		7.8
D	2.80		3.00	110.2		118.1
E	2.60		3.00	102.3		118.1
E1	1.50		1.75	59.0		68.8
e		0.95			37.4	
e1		1.9			74.8	
L	0.35		0.55	13.7		21.6

### 3.2 SO8 package information

Figure 20. SO8 package outline

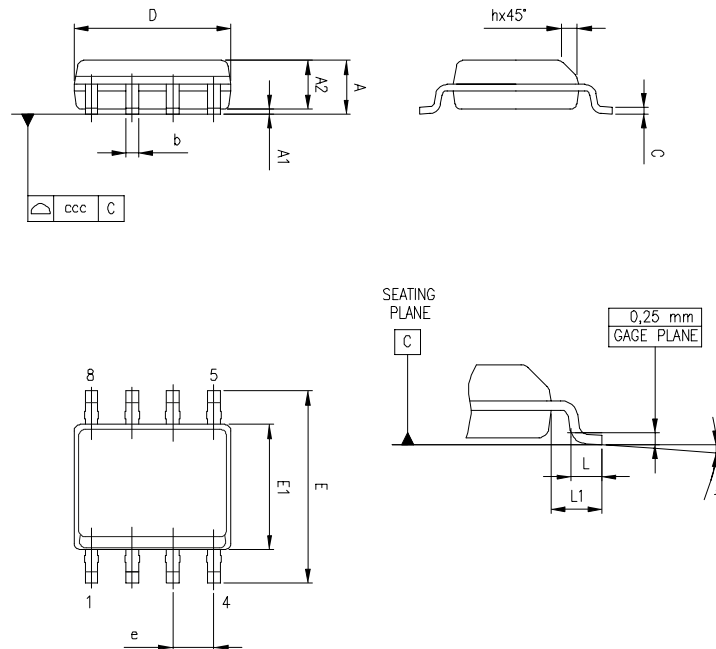

Table 6. SO-8 mechanical data

Dim.	mm			Inches		
	Min.	Typ.	Max.	Min.	Typ.	Max.
A			1.75			0.069
A1	0.1		0.25	0.004		0.01
A2	1.25			0.049		
b	0.28		0.48	0.011		0.019
c	0.17		0.23	0.007		0.01
D	4.8	4.9	5	0.189	0.193	0.197
E	5.8	6	6.2	0.228	0.236	0.244
E1	3.8	3.9	4	0.15	0.154	0.157
e		1.27			0.05	
h	0.25		0.5	0.01		0.02
L	0.4		1.27	0.016		0.05
L1		1.04			0.04	
k	0		8°	1°		8°
ccc			0.1			0.004

### 3.3 MiniSO8 package information

Figure 21. MiniSO8 package outline

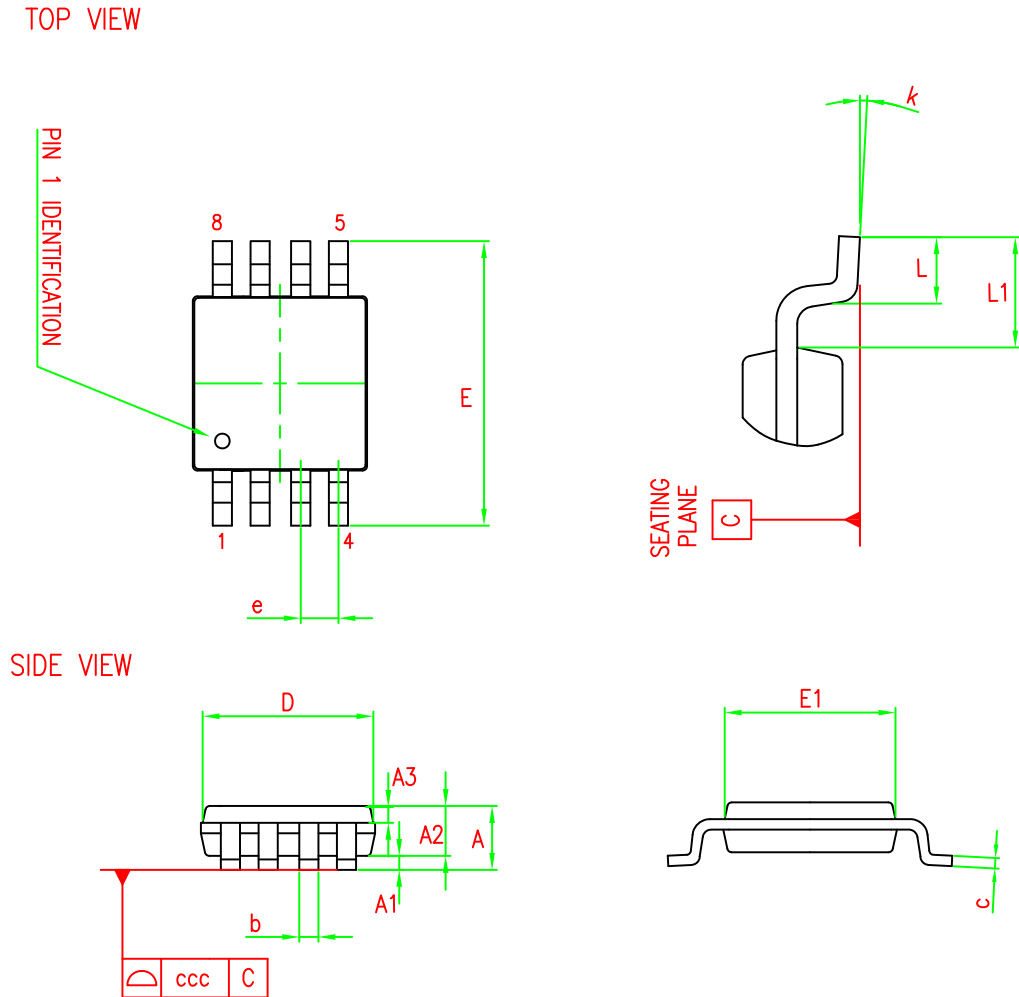
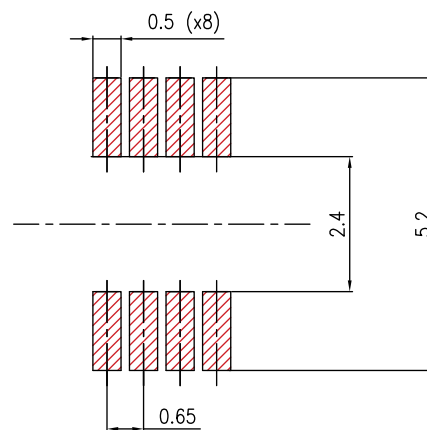

Table 7. MiniSO8 package mechanical data

Dim.	Millimeters			Inches		
	Min.	Typ.	Max.	Min.	Typ.	Max.
A			1.10			1.10
A1	0		0.15	0.05		0.15
A2	0.75	0.85	0.95	0.75	0.85	0.95
A3	0.30	0.35	0.40	0.30	0.35	0.40
b	0.22		0.40	0.28		0.36
c	0.08		0.23	0.15		0.19
D	2.80	3.00	3.20	2.90	3.00	3.10
E	4.65	4.90	5.15	4.70	4.90	5.10
E1	2.80	3.00	3.10	2.90	3.00	3.10
e		0.65			0.65	
L	0.40	0.60	0.80	0.40		0.70
L1		0.95			0.95	
k	0		8	0		8
ccc			0.10			0.10

Note: TSSOP stands for thin shrink small outline package. Dimensions "D" and "E1" do not include mold flash or protrusions. Mold flash or protrusions shall not exceed 0.15 mm per side.

Figure 22. MiniSO8 recommended footprint



### 3.4 TSSOP8 package information

Figure 23. TSSOP8 package outline

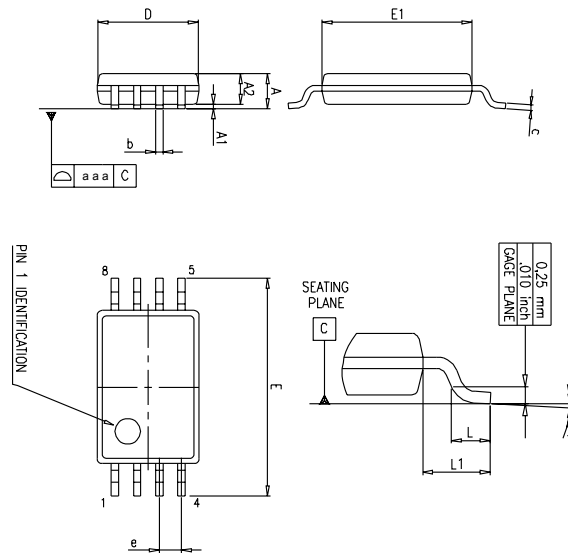

Table 8. TSSOP8 package mechanical data

Symbol	Dimensions					
	Millimeters			Inches		
	Min.	Typ.	Max.	Min.	Typ.	Max.
A			1.2			0.047
A1	0.05		0.15	0.002		0.006
A2	0.80	1.00	1.05	0.031	0.039	0.041
b	0.19		0.30	0.007		0.012
c	0.09		0.20	0.004		0.008
D	2.90	3.00	3.10	0.114	0.118	0.122
E	6.20	6.40	6.60	0.244	0.252	0.260
E1	4.30	4.40	4.50	0.169	0.173	0.177
e		0.65			0.0256	
k	0°		8°	0°		8°
L	0.45	0.60	0.75	0.018	0.024	0.030
L1		1			0.039	
aaa		0.1			0.004	

### 3.5 SO14 package information

Figure 24. SO14 package outline

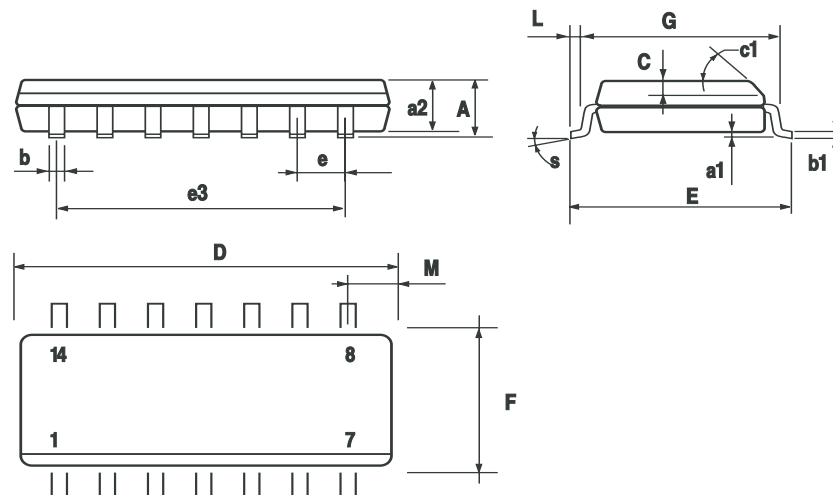

Table 9. SO14 package mechanical data

Symbol	Dimensions					
	Millimeters			Inches		
	Min.	Typ.	Max.	Min.	Typ.	Max.
D	8.55		8.75	0.336		0.344
E	5.8		6.2	0.228		0.244
e		1.27			0.050	
e3		7.62			0.300	
F	3.8		4.0	0.149		0.157
G	4.6		5.3	0.181		0.208
L	0.5		1.27	0.019		0.050
M			0.68			0.026
A			1.75			0.068
a1	0.1		0.2	0.003		0.007
a2			1.65			0.064
b	0.35		0.46	0.013		0.018
b1	0.19		0.25	0.007		0.010
C		0.5			0.019	
c1	45° (typ.)					
S	8° (max.)					

### 3.6 TSSOP14 package information

Figure 25. TSSOP14 package outline

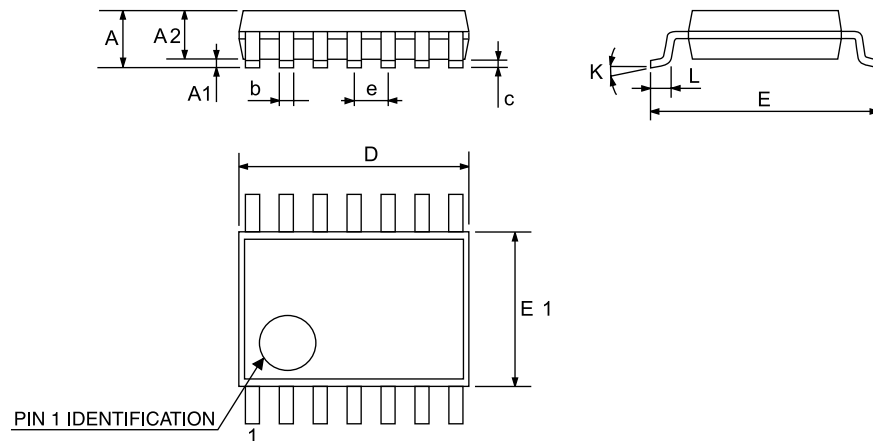

Table 10. TSSOP14 package mechanical data

Symbol	Dimensions					
	Millimeters			Inches		
	Min.	Typ.	Max.	Min.	Typ.	Max.
A			1.2			0.047
A1	0.05		0.15	0.002	0.004	0.006
A2	0.8	1	1.05	0.031	0.039	0.041
b	0.19		0.30	0.007		0.012
c	0.09		0.20	0.004		0.0089
D	4.9	5	5.1	0.193	0.197	0.201
E	6.2	6.4	6.6	0.244	0.252	0.260
E1	4.3	4.4	4.48	0.169	0.173	0.176
e		0.65 BSC			0.0256 BSC	
K	0°		8°	0°		8°
L1	0.45	0.60	0.75	0.018	0.024	0.030



## 4 Ordering information

**Table 11. Order codes**

Order code	Channels	Enhanced Vio	Temperature range	Package	Marking
TSV321RAILT	1	•	-40 °C to 125 °C	SOT23-5	K178
TSV321RILT	1			SOT23-5	K174
TSV358AIST	2	•		MiniSO8	K184
TSV358IST	2			MiniSO8	K175
TSV358IPT	2			TSSOP8	V358I
TSV358AIDT	2	•		SO8	V358AI
TSV358IDT	2			SO8	V358ID
TSV324IPT	4			TSSOP14	V324IP
TSV324IDT	4			SO14	V324ID
TSV321RAIYLT	1	•	-40 °C to 125 °C automotive grade <sup>(1)</sup>	SOT23-5	K187
TSV321RIYLT	1			SOT23-5	K179
TSV358AIYPT	2	•		TSSOP8	V58AY
TSV358IYPT	2			TSSOP8	V358Y
TSV358AIYDT	2	•		SO8	V358AY
TSV358IYDT	2			SO8	TV358Y
TSV324AIYPT	4	•		TSSOP14	V324AY
TSV324IYPT	4			TSSOP14	TSV324Y
TSV324AIYDT	4	•		SO14	V324AY
TSV324IYDT	4		SO14	V324YD	

1. Qualified and characterized according to AEC Q100 and Q003 or equivalent, advanced screening according to AEC Q001 & Q 002 or equivalent.

## Revision history

**Table 12. Document revision history**

Date	Revision	Changes
2-Aug-2005	1	First release - Products in full production.
20-Sep-2005	2	Addition of TS321A/TS324A/TS358A data in tables in Section 2: "Electrical characteristics". Minor formatting and grammatical changes.
7-Dec-2005	3	Missing PPAP references inserted see Section 4: "Ordering information".
28-Jun-2007	4	Correction made on output drive capability, 80 mA in description on cover page. SVR measurement conditions inserted in electrical characteristics tables. Offset voltage limit in temperature added in Section 2: "Electrical characteristics". Correction made on Input Bias Current typical value in Section 2: "Electrical characteristics". Captions of electrical characteristics figures updated. Automotive grade order codes added to Section 4: "Ordering information".
21-Feb-2008	5	Corrected SO-14 $R_{thja}$ value to 105 °C/W. Updated presentation of package information. Corrected footnote for automotive grade order codes in order code table.
13-Sep-2012	6	Updated Features (added SO-8, SO-14, TSSOP8, TSSOP14, and MiniSO-8 package). Updated "Pin connection" figure on page 1 (removed part numbers). Removed TSV321ID, TSV321AID, TSV321YDT, TSV358ID, TSV358AID, TSV324ID, TSV324AID, TSV321YD, TSV358YD, TSV358AIYD, TSV321YD, TSV324YD, and TSV324AIYD order code from Table 11: "Order codes". Qualified status of TSV324AIYPT, TSV324IYPT, TSV324YDT, TSV324AIYDT, TSV358IYDT, TSV321RIYLT, TSV321RAIYLT, and TSV358AIYDT order code in Table 11: "Order codes". Updated ECOPACK text in Section 3: "Package information". Minor corrections throughout document.
16-Aug-2013	7	Updated Features Added Related products Table 3 and Table 4: replaced $\Delta V_{io}$ with $\Delta V_{io}/\Delta T$ Table 11: "Order codes": order code TSV321IDT renamed TSV321AIDT, added order code TSV358AIDT, updated footnote associated with order codes TSV358IYPT and TSV358AIYPT.
27-JUN-2014	8	Added part numbers TSV321A, TSV358A, and TSV324A. Table 6: "SO8 package mechanical data": added L1 dimensions Table 11: "Order codes": removed "tube" from all packaging Updated disclaimer
24-Nov-2021	9	Updated Table 11. Order codes.



## Contents

<b>1</b>	<b>Absolute maximum ratings and operating conditions</b>	<b>2</b>
<b>2</b>	<b>Electrical characteristics</b>	<b>4</b>
<b>3</b>	<b>Package information</b>	<b>9</b>
<b>3.1</b>	SOT23-5 package information	10
<b>3.2</b>	SO8 package information	11
<b>3.3</b>	MiniSO8 package information	12
<b>3.4</b>	TSSOP8 package information	14
<b>3.5</b>	SO14 package information	15
<b>3.6</b>	TSSOP14 package information	16
<b>4</b>	<b>Ordering information</b>	<b>17</b>
	<b>Revision history</b>	<b>18</b>



**IMPORTANT NOTICE – PLEASE READ CAREFULLY**

STMicroelectronics NV and its subsidiaries (“ST”) reserve the right to make changes, corrections, enhancements, modifications, and improvements to ST products and/or to this document at any time without notice. Purchasers should obtain the latest relevant information on ST products before placing orders. ST products are sold pursuant to ST’s terms and conditions of sale in place at the time of order acknowledgement.

Purchasers are solely responsible for the choice, selection, and use of ST products and ST assumes no liability for application assistance or the design of Purchasers’ products.

No license, express or implied, to any intellectual property right is granted by ST herein.

Resale of ST products with provisions different from the information set forth herein shall void any warranty granted by ST for such product.

ST and the ST logo are trademarks of ST. For additional information about ST trademarks, please refer to [www.st.com/trademarks](http://www.st.com/trademarks). All other product or service names are the property of their respective owners.

Information in this document supersedes and replaces information previously supplied in any prior versions of this document.

© 2021 STMicroelectronics – All rights reserved

单击下面可查看定价，库存，交付和生命周期等信息

[>>STMicro\(意法半导体\)](#)