

Automotive-grade dual N-channel 30 V, 0.016 Ω typ., 40 A STripFET™ H5 Power MOSFET in a PowerFLAT™ 5x6 DI package

Datasheet - production data

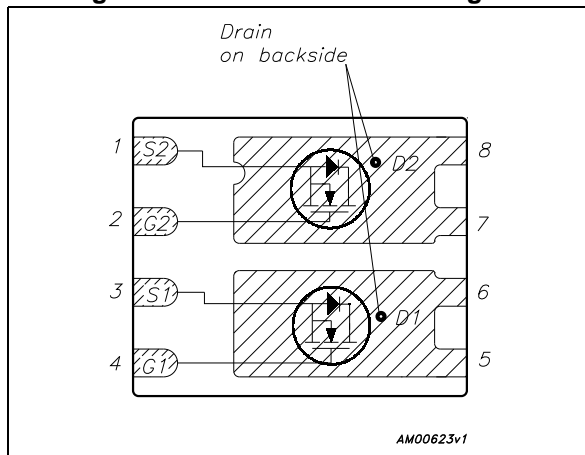

Figure 1. Internal schematic diagram



Features

Order code	V _{DS}	R _{DS(on)} max.	I _D
STL40DN3LLH5	30 V	0.018 Ω	40 A



- AEC-Q101 qualified
- Low on-resistance
- High avalanche ruggedness
- Low gate drive power loss
- Wettable flank package

Applications

- Switching applications

Description

This device is an N-channel Power MOSFET developed using STMicroelectronics' STripFET™ H5 technology. The device has been optimized to achieve very low on-state resistance, contributing to a FoM that is among the best in its class.

Table 1. Device summary

Order code	Marking	Package	Packing
STL40DN3LLH5	40DN3LLH5	PowerFLAT™ 5x6 double island	Tape and reel

Contents

1	Electrical ratings	3
2	Electrical characteristics	4
2.1	Electrical characteristics (curves)	6
3	Test circuits	8
4	Package information	9
4.1	PowerFLAT 5x6 double island WF type R	10
5	Packing information	13
6	Revision history	15



1 Electrical ratings

Table 2. Absolute maximum ratings

Symbol	Parameter	Value	Unit
V_{DS}	Drain-source voltage	30	V
V_{GS}	Gate-source voltage	± 22	V
$I_D^{(1)}$	Drain current (continuous) at $T_C = 25^\circ\text{C}$	40	A
$I_D^{(1)}$	Drain current (continuous) at $T_C = 100^\circ\text{C}$	28	A
$I_D^{(2)}$	Drain current (continuous) at $T_{pcb} = 25^\circ\text{C}$	11	A
$I_D^{(2)}$	Drain current (continuous) at $T_{pcb}=100^\circ\text{C}$	7	A
$I_{DM}^{(2)(3)}$	Drain current (pulsed)	44	A
$I_{DM}^{(1)(3)}$	Drain current (pulsed)	160	A
$P_{TOT}^{(1)}$	Total dissipation at $T_C = 25^\circ\text{C}$	50	W
$P_{TOT}^{(2)}$	Total dissipation at $T_{pcb} = 25^\circ\text{C}$	4.7	W
T_J	Operating junction temperature range	-55 to 175	$^\circ\text{C}$
T_{stg}	Storage temperature range		

1. The value is rated according R_{thj-c}
2. The value is rated according $R_{thj-pcb}$
3. Pulse width limited by safe operating area

Table 3. Thermal resistance

Symbol	Parameter	Value	Unit
$R_{thj-case}$	Thermal resistance junction-case	3.0	$^\circ\text{C}/\text{W}$
$R_{thj-pcb}^{(1)}$	Thermal resistance junction-pcb	32	$^\circ\text{C}/\text{W}$

1. When mounted on FR-4 board of 1inch², 2oz Cu, $t < 10$ s

2 Electrical characteristics

($T_{CASE}=25\text{ °C}$ unless otherwise specified)

Table 4. On/off states

Symbol	Parameter	Test conditions	Min.	Typ.	Max.	Unit
$V_{(BR)DSS}$	Drain-source breakdown voltage	$I_D = 250\ \mu\text{A}$, $V_{GS} = 0\ \text{V}$	30			V
I_{DSS}	Zero gate voltage drain current	$V_{DS} = 30\ \text{V}$, $V_{GS} = 0\ \text{V}$			1	μA
		$V_{DS} = 30\ \text{V}$, $V_{GS} = 0\ \text{V}$, $T_J = 125\text{ °C}^{(1)}$			10	μA
I_{GSS}	Gate body leakage current	$V_{GS} = \pm 22\ \text{V}$, $V_{DS} = 0\ \text{V}$			± 100	nA
$V_{GS(th)}$	Gate threshold voltage	$V_{DS} = V_{GS}$, $I_D = 250\ \mu\text{A}$	1	1.5		V
$R_{DS(on)}$	Static drain-source on resistance	$V_{GS} = 10\ \text{V}$, $I_D = 5.5\ \text{A}$		0.016	0.018	Ω
		$V_{GS} = 4.5\ \text{V}$, $I_D = 5.5\ \text{A}$		0.02	0.025	Ω

1. Defined by design, not subject to production test

Table 5. Dynamic

Symbol	Parameter	Test conditions	Min.	Typ.	Max.	Unit
C_{iss}	Input capacitance	$V_{DS} = 25\ \text{V}$, $f = 1\ \text{MHz}$, $V_{GS} = 0\ \text{V}$	-	475	-	pF
C_{oss}	Output capacitance		-	97	-	pF
C_{rss}	Reverse transfer capacitance		-	19	-	pF
Q_g	Total gate charge	$V_{DD} = 15\ \text{V}$, $I_D = 11\ \text{A}$ $V_{GS} = 4.5\ \text{V}$ (see Figure 13)	-	4.5	-	nC
Q_{gs}	Gate-source charge		-	1.7	-	nC
Q_{gd}	Gate-drain charge		-	1.9	-	nC

Table 6. Switching times

Symbol	Parameter	Test conditions	Min.	Typ.	Max.	Unit
$t_{d(on)}$	Turn-on delay time	$V_{DD} = 15\ \text{V}$, $I_D = 11\ \text{A}$, $R_G = 4.7\ \Omega$, $V_{GS} = 10\ \text{V}$ (see Figure 12)	-	4	-	ns
t_r	Rise time		-	22	-	ns
$t_{d(off)}$	Turn-off delay time		-	13	-	ns
t_f	Fall time		-	2.8	-	ns

Table 7. Source drain diode

Symbol	Parameter	Test conditions	Min.	Typ.	Max.	Unit
$V_{SD}^{(1)}$	Forward on voltage	$I_{SD} = 11 \text{ A}$, $V_{GS} = 0 \text{ V}$	-		1.1	V
t_{rr}	Reverse recovery time	$I_{SD} = 11 \text{ A}$, $di/dt = 100 \text{ A}/\mu\text{s}$, $V_{DD} = 25 \text{ V}$, $T_j = 150 \text{ }^\circ\text{C}$	-	16.2		ns
Q_{rr}	Reverse recovery charge		-	1		nC
I_{RRM}	Reverse recovery current		-	8.1		A

1. Pulsed: pulse duration=300 μs , duty cycle 1.5%

2.1 Electrical characteristics (curves)

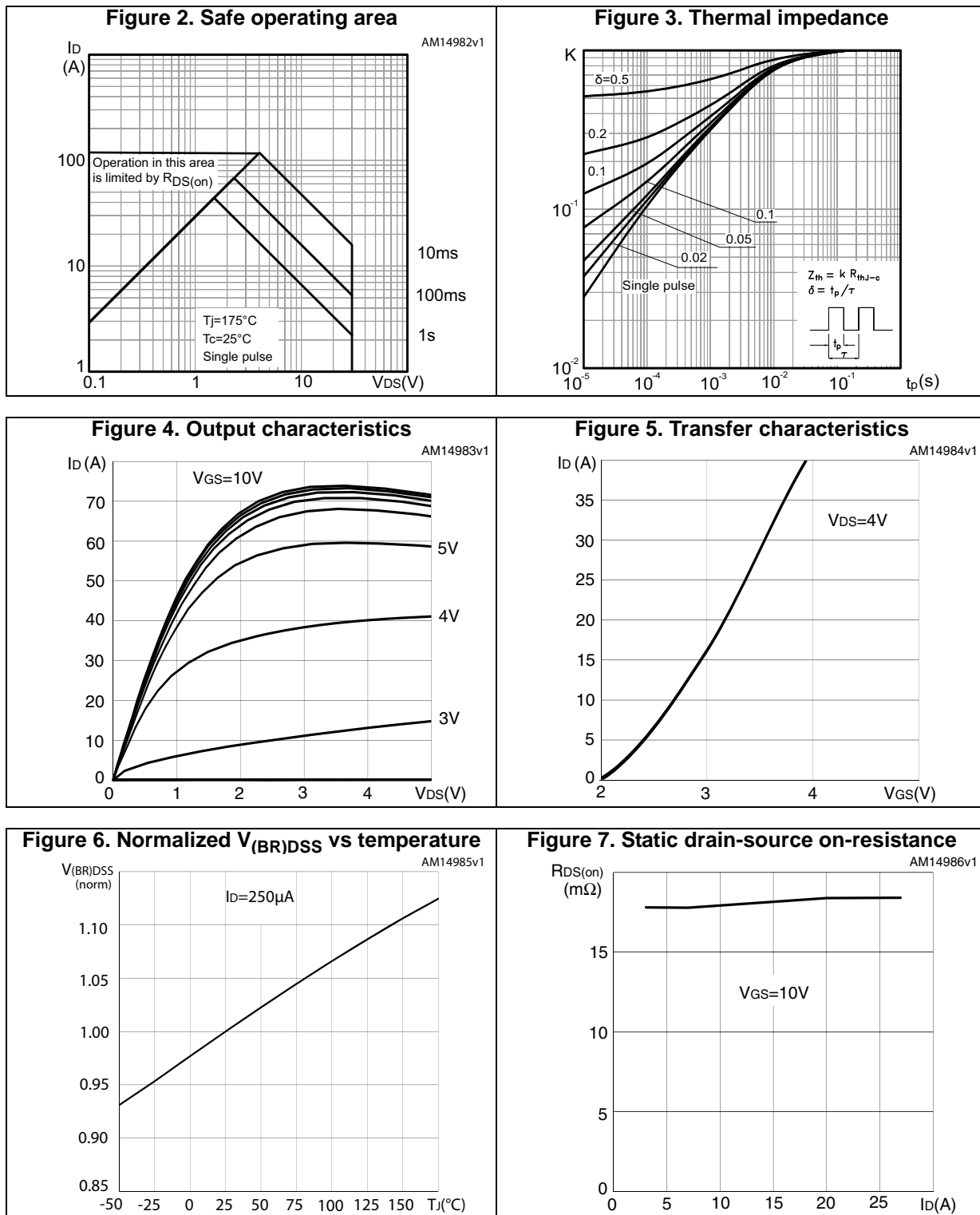

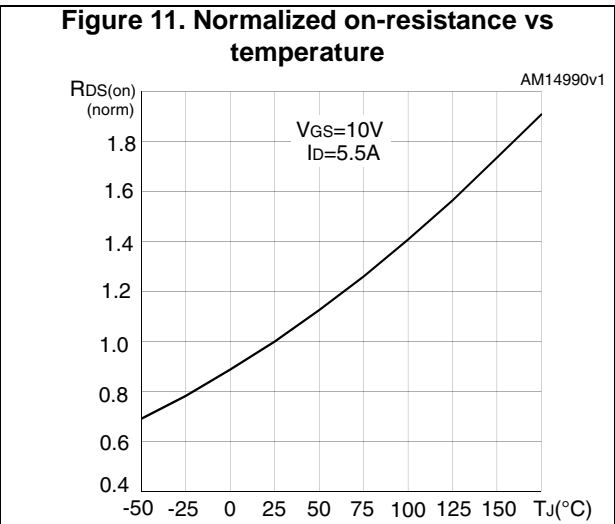
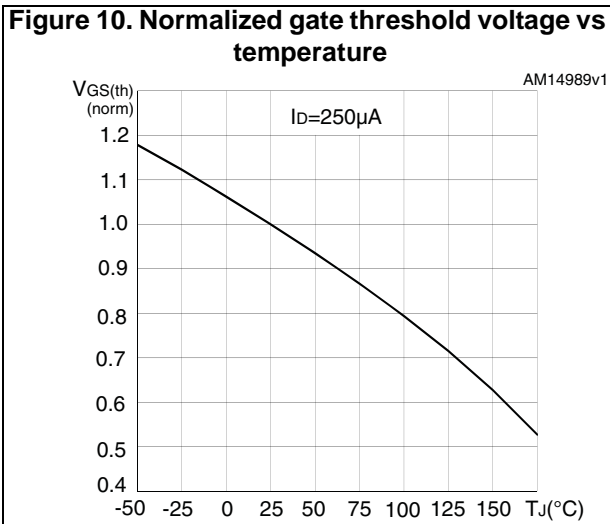
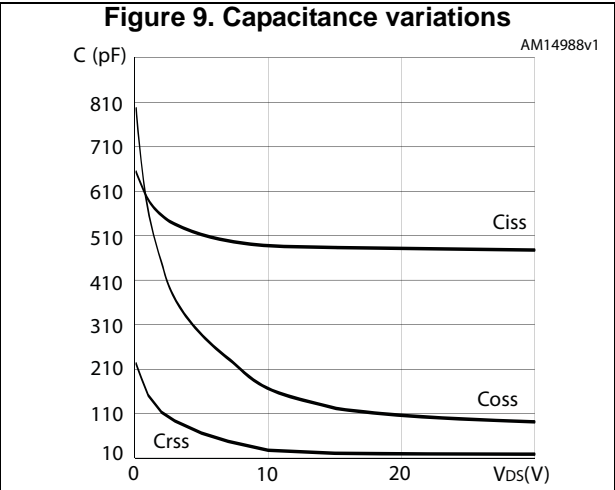
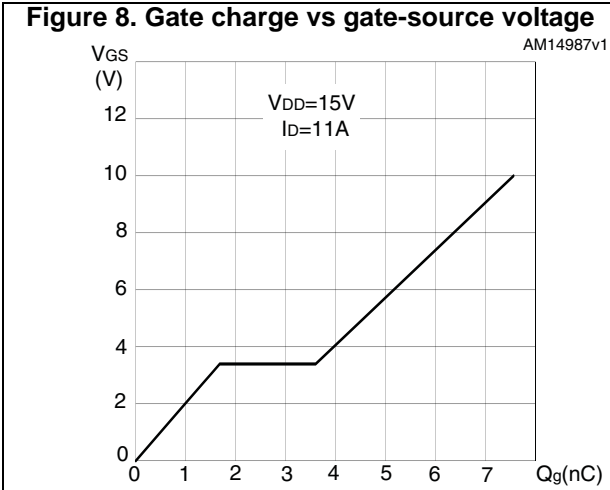

3 Test circuits

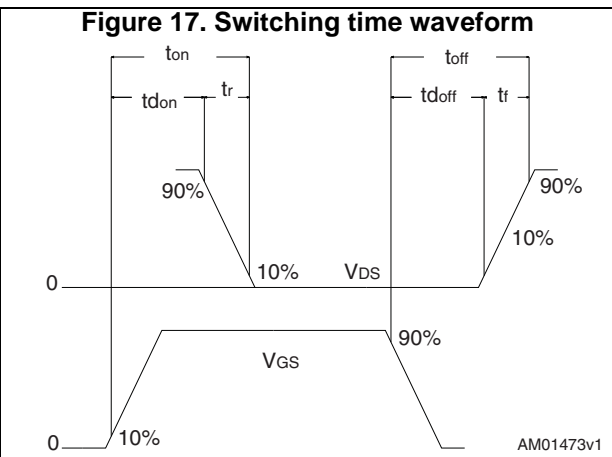
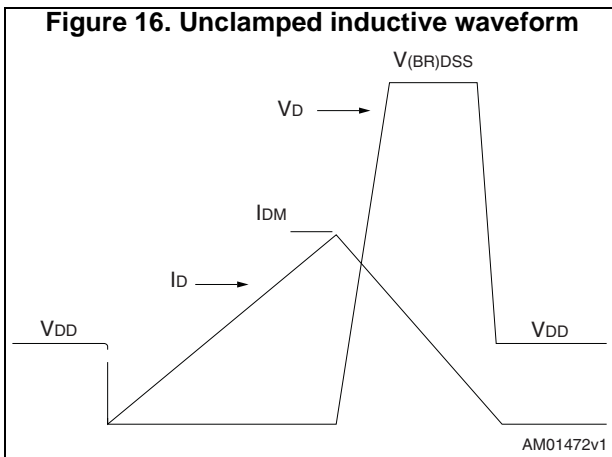
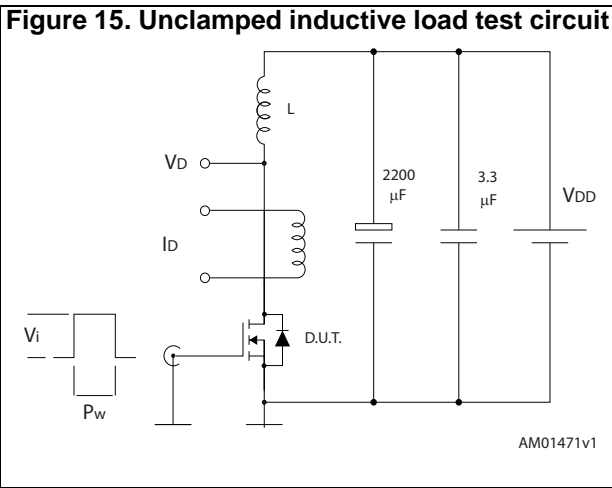
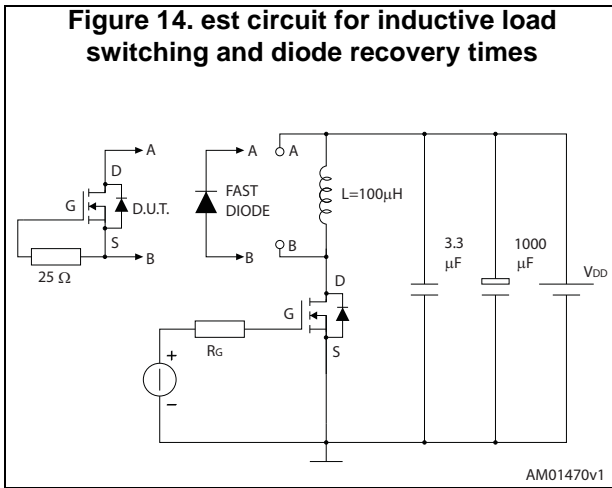
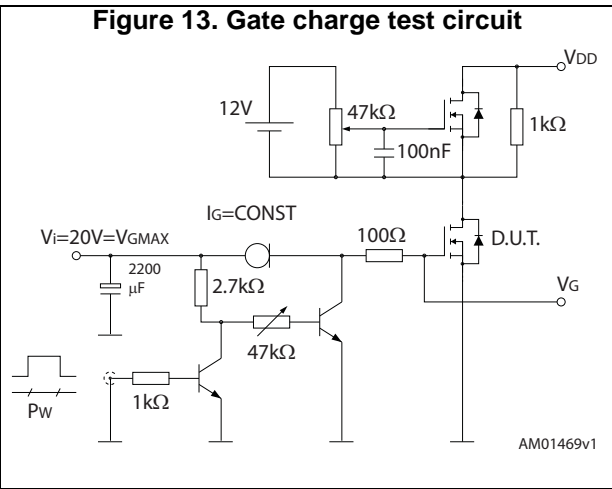
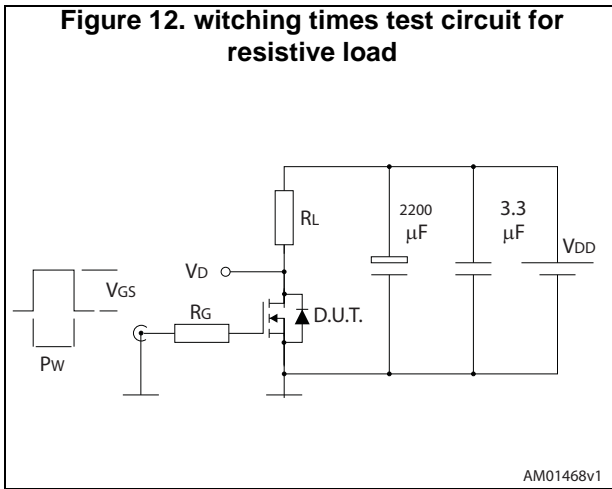

4 Package information

In order to meet environmental requirements, ST offers these devices in different grades of ECOPACK[®] packages, depending on their level of environmental compliance. ECOPACK[®] specifications, grade definitions and product status are available at: www.st.com. ECOPACK[®] is an ST trademark.

4.1 PowerFLAT 5x6 double island WF type R

Figure 18. PowerFLAT 5x6 double island WF type R outline

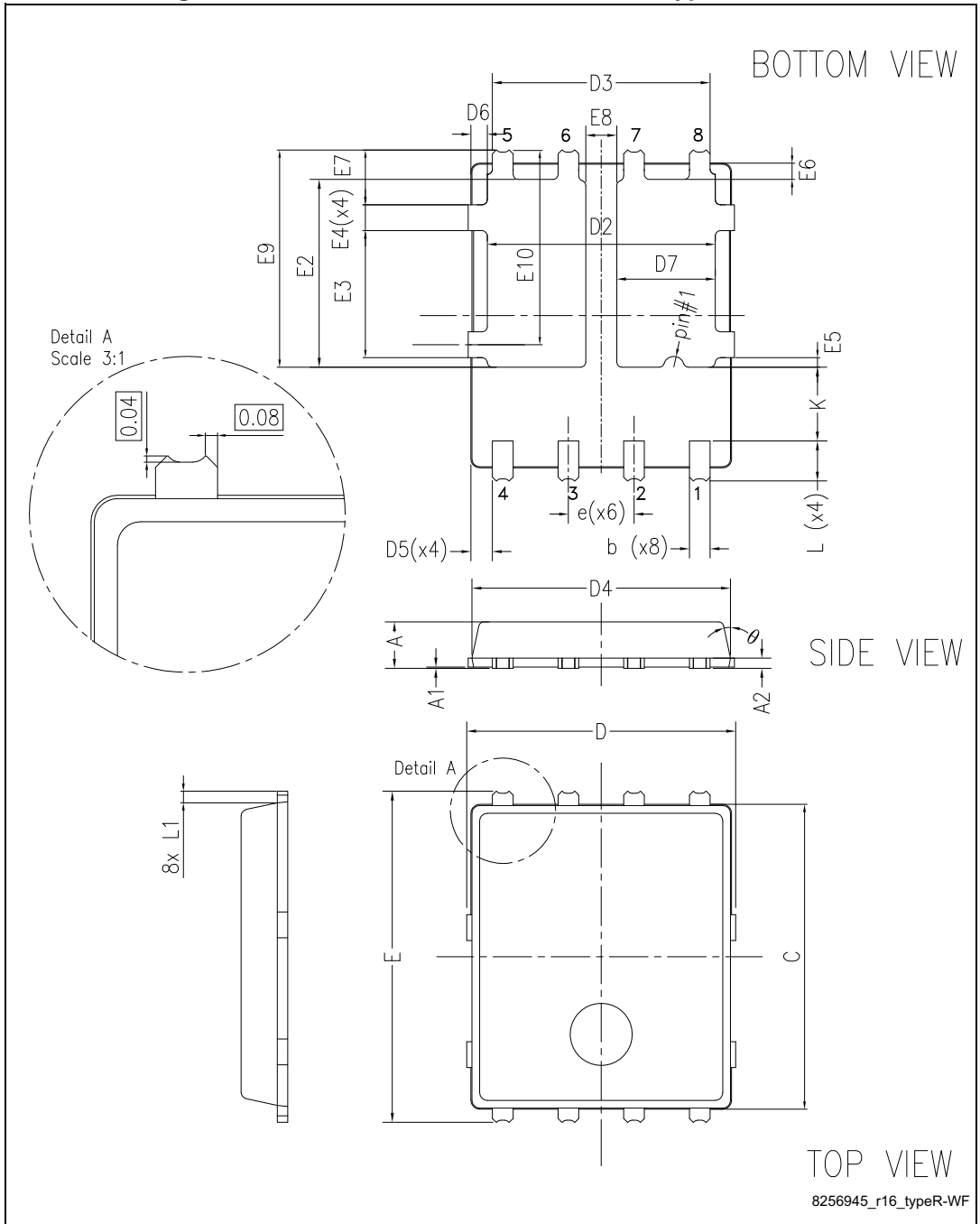

Table 8. PowerFLAT 5x6 double island WF type R mechanical data

Ref.	Dimensions (mm)		
	Min.	Typ.	Max.
A	0.80		1.00
A1	0.02		0.05
A2		0.25	
b	0.30		0.50
C	5.80	6.00	6.20
D	5.00	5.20	5.40
D2	4.15		4.45
D3	4.05	4.20	4.35
D4	4.80	5.00	5.10
D5	0.25	0.40	0.55
D6	0.15	0.30	0.45
e		1.27	
E	6.20	6.40	6.60
E2	3.50		3.70
E3	2.35		2.55
E4	0.40		0.60
E5	0.08		0.28
E6	0.20	0.325	0.45
E7	0.85	1.00	1.15
E8	0.55	1.00	0.75
E9	4.00	4.20	4.40
E10	3.55	3.70	3.85
K	1.275		1.575
L	0.725	0.825	0.925
L1	0.175	0.275	0.375
θ	0°		12°

5 Packing information

Figure 20. PowerFLAT™ 5x6 WF tape

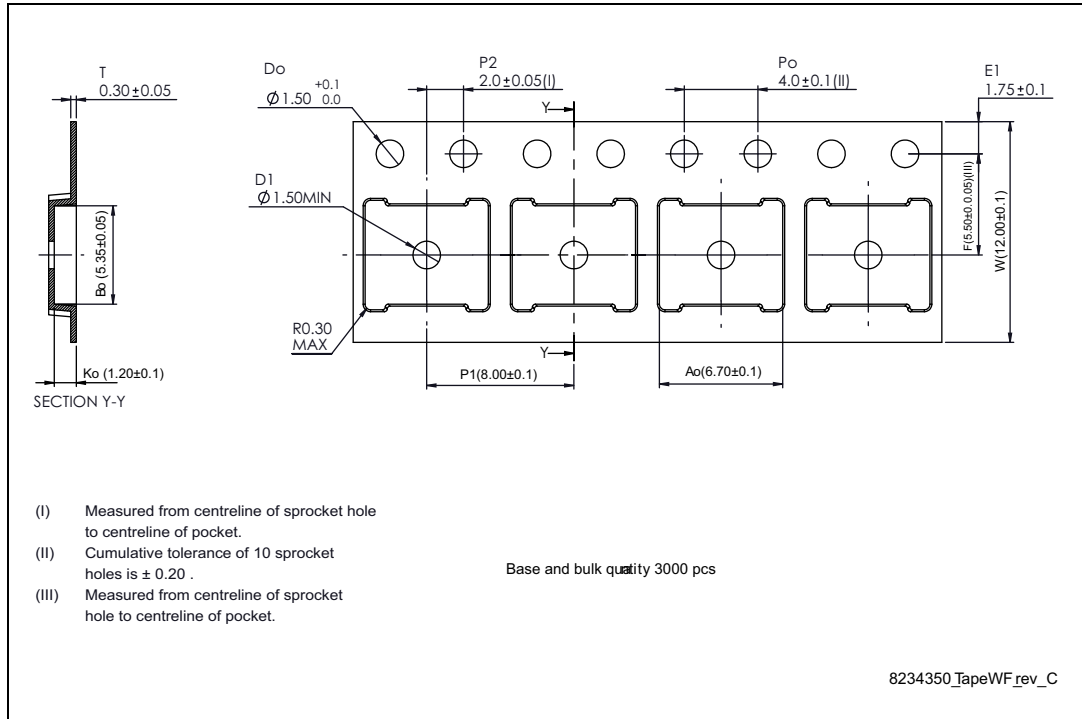

Figure 21. PowerFLAT™ 5x6 package orientation in carrier tape

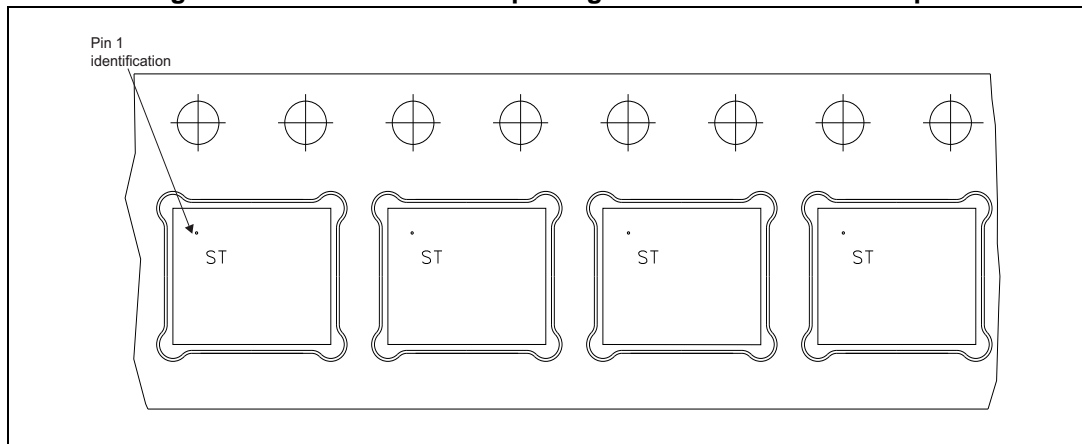
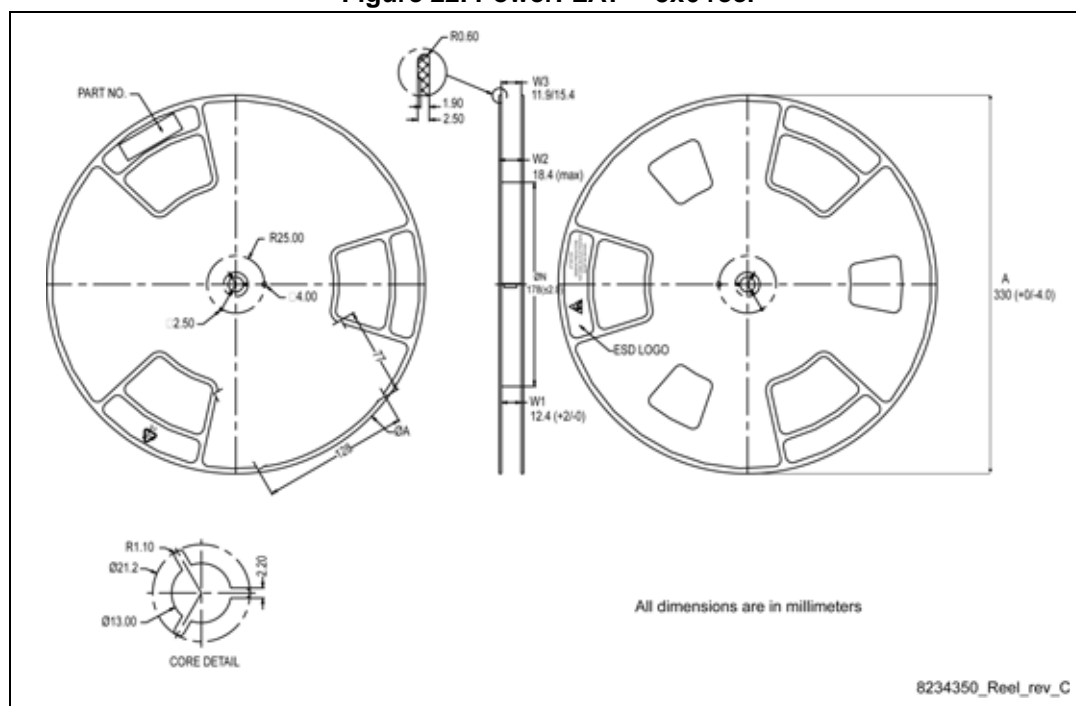

Figure 22. PowerFLAT™ 5x6 reel



6 Revision history

Table 9. Document revision history

Date	Revision	Changes
24-Jan-2011	1	First release.
03-Oct-2012	2	Section 2.1: Electrical characteristics (curves) has been added. Document status promoted from preliminary data to datasheet. Minor text changes.
14-Dec-2012	3	Modified the Applications section on the coverpage to "Automotive switching applications".
23-Feb-2015	4	Updated Section 4: Package mechanical data and added Section 5: Packing information. Updated title and features in cover page. Minor text changes.
27-Oct-2015	5	Updated title and features in cover page. Updated <i>Table 2, Table 3, Table 4 and Table 7</i> . Updated <i>Section 4: Package information</i> Minor text changes.
11-Mar-2016	6	Updated silhouette in cover page. Updated <i>Table 1: Device summary, Table 2: Absolute maximum ratings, Table 3: Thermal resistance and Table 4: On/off states</i> . Updated <i>Figure 2: Safe operating area</i> . Updated <i>Section 4.1: PowerFLAT 5x6 double island WF type R</i> Updated <i>Section 5: Packing information</i> . Minor text changes.
7-Oct-2016	7	Updated marking and <i>Section 4.1: PowerFLAT 5x6 double island WF type R</i> . Minor text changes.

IMPORTANT NOTICE – PLEASE READ CAREFULLY

STMicroelectronics NV and its subsidiaries ("ST") reserve the right to make changes, corrections, enhancements, modifications, and improvements to ST products and/or to this document at any time without notice. Purchasers should obtain the latest relevant information on ST products before placing orders. ST products are sold pursuant to ST's terms and conditions of sale in place at the time of order acknowledgement.

Purchasers are solely responsible for the choice, selection, and use of ST products and ST assumes no liability for application assistance or the design of Purchasers' products.

No license, express or implied, to any intellectual property right is granted by ST herein.

Resale of ST products with provisions different from the information set forth herein shall void any warranty granted by ST for such product.

ST and the ST logo are trademarks of ST. All other product or service names are the property of their respective owners.

Information in this document supersedes and replaces information previously supplied in any prior versions of this document.

© 2016 STMicroelectronics – All rights reserved

单击下面可查看定价，库存，交付和生命周期等信息

[>>STMicro\(意法半导体\)](#)